

TYPICAL END VIEW FOR 2 CIRCUIT ONLY

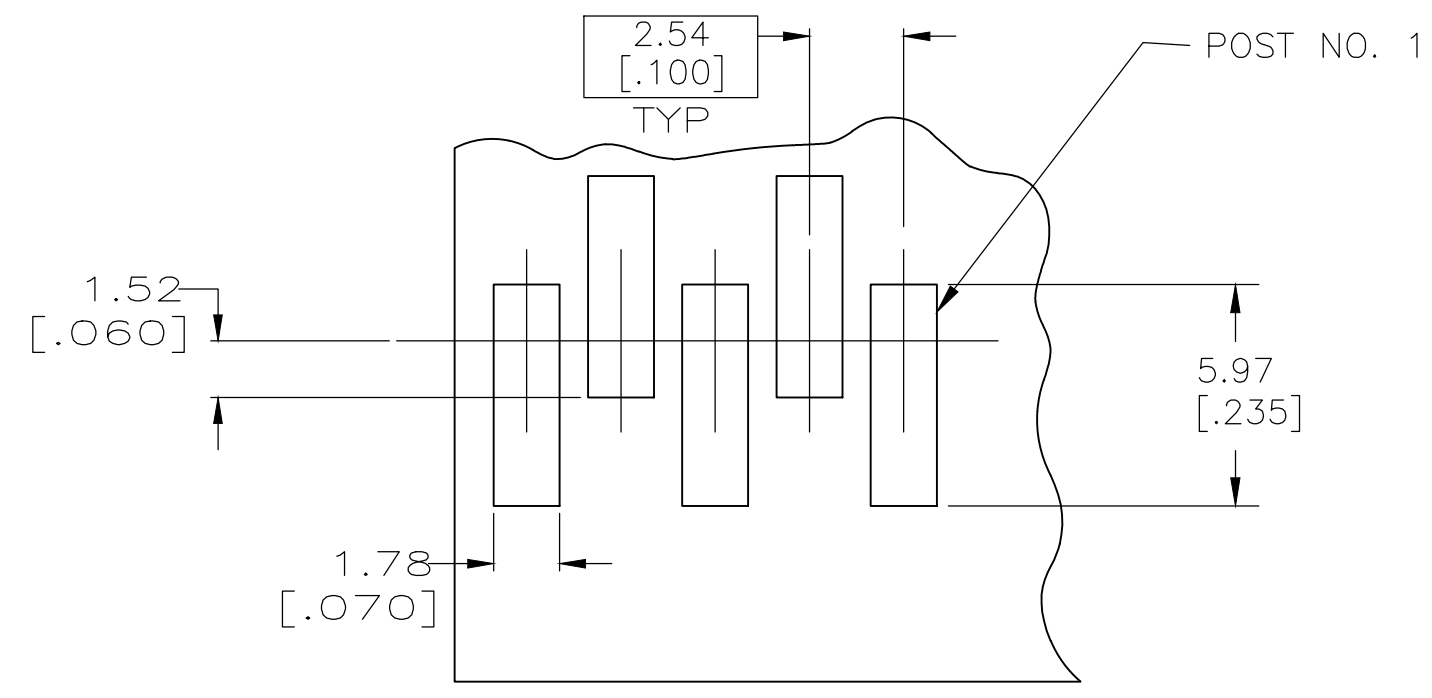
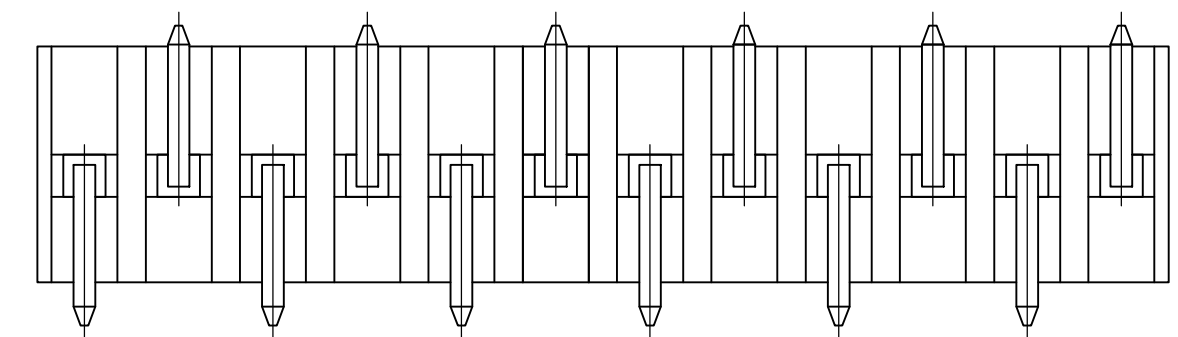
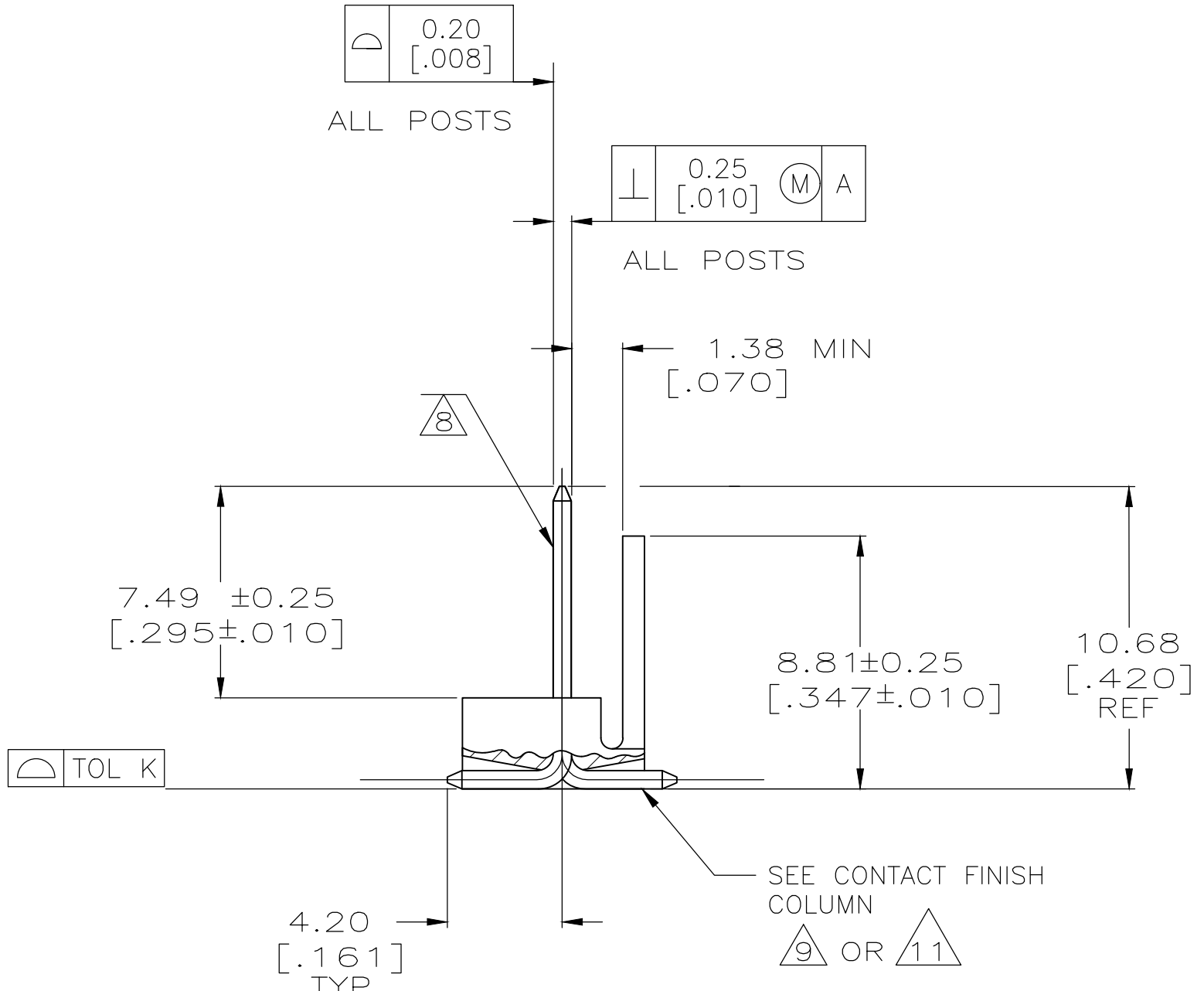
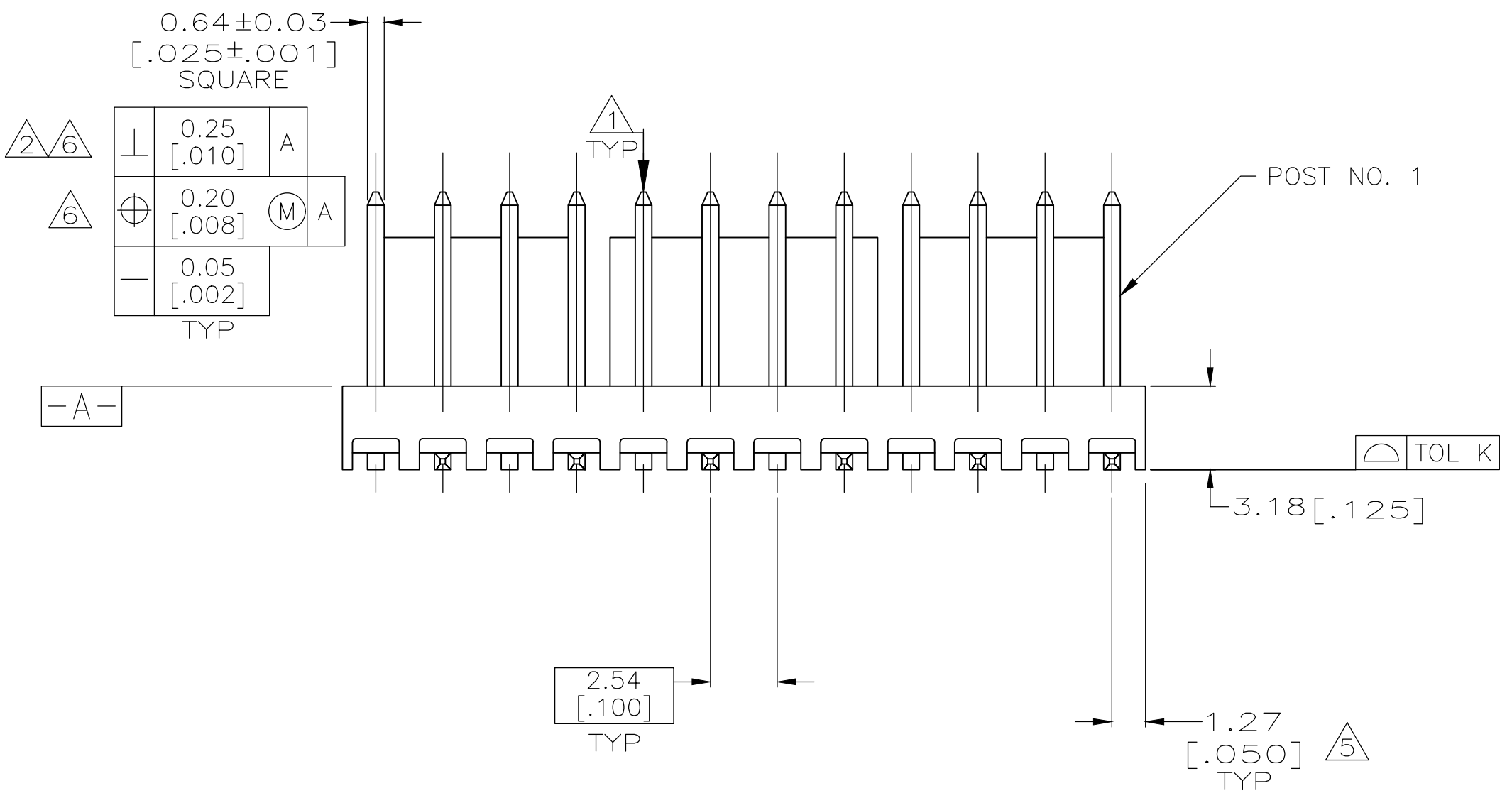

RECOMMENDED P.C. BOARD LAYOUT FOR USE WITH 0.25 [.010] THICK STENCIL

- 1 POST TO WITHSTAND 13 NEWTONS (3 LBS) MIN. AXIAL FORCE. IN DIRECTION SHOWN WITHOUT DISLODGING.
- 2 MEASURED AT SURFACE -A-
- 3 PARTS COMPLY WITH AMP SOLDERABILITY SPEC. NO. 109-11-2.
- 4 MATERIAL:
HOUSING: NYLON, 4/6, HIGH TEMP, BLACK.
POST: COPPER ALLOY, (SEE NOTES 8, 9 & 13 FOR PLATING).
- 5 COORDINATE DIMENSION APPLIES FROM CENTER OF ACTUAL FEATURE.
- 6 POSTS TO BE MEASURED WHEN STRIP IS HELD FLAT.
- 7 DIMENSIONS IN BRACKETS ARE IN INCHES.
- 8 PLATING: GOLD PLATE AREA, 0.00076 [.000030] GOLD OR 0.00008 [.000003] MIN GOLD FLASH OVER 0.00068 [.000027] PALLADIUM NICKEL, PER TE CONNECTIVITY'S DISCRETION, ALL SIDES, OVER NICKEL UNDERPLATE, 0.00127 [.000050] MIN, ALL SIDES AND ENTIRE LENGTH OF POST.
- 9 BRIGHT TIN/LEAD (93/7) PLATE AREA, 0.00381-0.00889 [.000150-.000350] THICK, ALL FOUR SIDES, 3.56[.140] MIN.
- 10 TE LOGO AND UL AND CSA TRADEMARKS TO APPEAR ON THIS SURFACE.
- 11 MATTE TIN PLATE AREA, 0.00381-0.00889[.000150-.000350] THICK, ALL FOUR SIDES, 3.56[.140] MIN.
- 12 ALL FOUR SIDES, 3.56[.140] MIN.
OBSOLETE PARTS: OBSOLETE CIS STREAMLINING PER D.RENAUD/D.SINISI

POST FINISH	MM	[IN]	MM	[IN]	MM	[IN]	MM	[IN]	NO OF POSITIONS	PART NUMBER
	TOL K		W		G		L			
8, 11	0.15	.006	10.16	.400	12.70	.500	30.48	1.200	12	4-647108-2
	0.15	.006	-	-	10.16	.400	27.94	1.100	11	4-647108-1
	0.15	.006	-	-	7.62	.300	25.40	1.000	10	4-647108-0
	0.15	.006	-	-	5.08	.200	22.86	.900	9	3-647108-9
	0.15	.006	-	-	2.54	.100	20.32	.800	8	3-647108-8
	0.15	.006	-	-	-	-	17.78	.700	7	3-647108-7
	0.15	.006	-	-	-	-	15.24	.600	6	3-647108-6
	0.15	.006	-	-	-	-	12.70	.500	5	3-647108-5
	0.15	.006	-	-	-	-	10.16	.400	4	3-647108-4
	0.15	.006	-	-	-	-	7.62	.300	3	3-647108-3
	0.15	.006	-	-	-	-	5.08	.200	2	3-647108-2
8, 9	0.15	.006	10.16	.400	12.70	.500	30.48	1.200	12	1-647108-2
	0.15	.006	-	-	10.16	.400	27.94	1.100	11	1-647108-1
	0.15	.006	-	-	7.62	.300	25.40	1.000	10	1-647108-0
	0.15	.006	-	-	5.08	.200	22.86	.900	9	647108-9
	0.15	.006	-	-	2.54	.100	20.32	.800	8	647108-8
	0.15	.006	-	-	-	-	17.78	.700	7	647108-7
	0.15	.006	-	-	-	-	15.24	.600	6	647108-6
	0.15	.006	-	-	-	-	12.70	.500	5	647108-5
	0.15	.006	-	-	-	-	10.16	.400	4	647108-4
	0.15	.006	-	-	-	-	7.62	.300	3	647108-3
	0.15	.006	-	-	-	-	5.08	.200	2	647108-2

12 SUPERSEDED

THIS DRAWING IS A CONTROLLED DOCUMENT.

DIMENSIONS: mm [INCHES]	TOLERANCES UNLESS OTHERWISE SPECIFIED:	DIN S. HOOVER 25-FEB-2003	APPROVED: D. ROSSI 25-FEB-2003	NAME: MTA-100 HEADER ASSEMBLY, SURFACE MOUNT, POLARIZED, STRAIGHT .025 SQUARE POST, .000030 GOLD
0 PLC ±	1 PLC ±	2 PLC ±	3 PLC ± 0.38 [.015]	APPLICATION SPEC
4 PLC ±	ANGLES ± 0°30'	MATERIAL	FINISH	WEIGHT

CUSTOMER DRAWING SCALE 5:1 SHEET 1 OF 1 REV N1