

PART NUMBER	REVISION	DESCRIPTION	FEED TYPE
2151160-2	D	FINE CRIMP HEIGHT ADJUST	PNEUMATIC
7-2151160-2	D	PNEUMATIC AND CRIMP TOOLING KIT	PNEUMATIC
7-2151160-7	B	CRIMP TOOLING KIT	-

ATLANTIC VERSION TERMINATOR INTERFACE ADAPTER

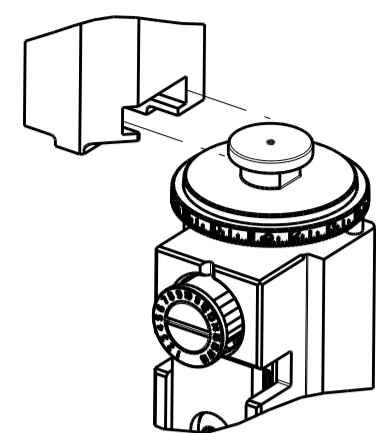

APPLICATOR DATA		
CRIMP	SIZE	TYPE
WIRE	2.79 mm [.110]	F
INSUL	3.56 mm [.140]	OV

APPLICATOR INSTRUCTIONS 408-35042

TERMINAL DATA: TE TERMINAL		TE CRIMP SPECIFICATION	
TERMINAL NAME: TAB 5.8 x 0.8			
WIRE STRIP LENGTH		INSULATION DIAMETER RANGE	
4.10-4.12 mm [.161-.162 IN]		Ø2.20-3.00 mm [.087-.118 IN]	
TERMINAL APPLICATION SPECIFICATION	114-18052		
TERMINALS APPLIED			
TE TERMINAL	TE TERMINAL	TE TERMINAL	TE TERMINAL
964306-1	964306-3		

WIRE SIZE	CRIMP HEIGHT mm [INCH]	CRIMP HEIGHT REFERENCE SETTING
2.50mm ²	1.97+/-0.05 [.078+/- .002]	5.4
(2)1.0mm ² OR (1)2.0mm ²	1.83+/-0.05 [.072+/- .002]	7.0
(1)1.5mm ² + (1)0.35mm ²	1.79+/-0.05 [.070+/- .002]	7.5
1.50mm ²	1.69+/-0.05 [.067+/- .002]	8.4

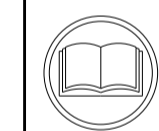

- RECOMMENDED SPARE PARTS
- REFER TO SUPPLIED INSTRUCTION SHEET FOR CLEANING, LUBRICATION AND STORAGE OF APPLICATOR.
- APPLY PART NUMBER 2-23419-6 LOCTITE TO THREADS OF ITEM 242.
- CRIMP HEIGHT REFERENCE SETTING WAS THE SETTING USED WHEN THE APPLICATOR WAS QUALIFIED AT THE FACTORY. ADJUSTMENT MAY BE NECESSARY WHEN RUNNING APPLICATOR IN THE FIELD.
- TERMINAL PITCH NOT COMPATIBLE WITH MECHANICAL FEED.
- 6. UNLESS SPECIFIED OTHERWISE TORQUE VALUES SHALL BE USED PER DOCUMENT, 101-35000.

***WARNING**
ON INSTALLATION, SET WIRE DISC TO CRIMP HEIGHT REFERENCE SETTING FOR LARGEST WIRE SIZE. CRIMP HEIGHT REFERENCE SETTINGS GREATER THAN THE VALUE SHOWN MAY CAUSE DAMAGE TO THE CRIMP TOOLING. REFER TO THE INSTRUCTION SHEET FOR PROPER SETUP AND ADJUSTMENTS.

LOC	DIST	REVISIONS					
		P	LTN	DESCRIPTION	DATE	DWN	APVD
A	66	B		ECR-13-005960	08APR2013	YY	UG
		B1		ECR-13-012598	08AUG2013	XZ	TE
		C		ECR-18-006179	03MAY2018	TB	JDG
		D		ECR-19-005860	12APR2019	FJ	TE

-	1	1	2119641-1	FEED CAM, AIR FEED	248
-	1	1	2119082-9	CAM, SNAIL, INSULATION ADJUSTMENT	244
-	1	1	2079764-1	WASHER, WAVE SPRING, CREST-TO-CREST	243
-	1	1	2119083-1	RETAINER, INSULATION DIAL	242
-	1	1	18023-1	SCR, SKT HD CAP M3 X 5.0	241
-	1	1	2844940-1	AIR FEED MODULE	238
-	REF	REF	994970-2	COUNTER, MAGNETIC	164
-	1	1	18028-2	WASHER, FLAT, REG M4	119
-	1	1	2844908-1	SCREW, LOCKING	99
-	1	1	2844907-1	POST, LOCKING	98
-	1	1	455888-7	SPACER, CRIMPER	82
-	1	1	1-22278-0	SPRING, COMPRESSION	77
-	1	1	854769-4	HOLDER, INS	74
-	1	1	1803607-3	DOCUMENTATION PACKAGE	71
-	1	1	2119791-5	DEPRESSOR, WIRE	70
-	1	1	2119943-1	WASHER, SPACER	69
-	1	1	2119740-1	TAG IDENTIFICATION	67
-	2	2	2168078-1	SCREW, DRIVE, RH, RoHS, 2 x .188	66
-	1	1	2168083-2	SCR, SKT HD CAP, RoHS, M4 X 8.0	60
-	1	1	5-18022-5	SCR, HEX HD CAP, M4 X 6.0	59
-	1	1	21028-2	PIN, SLOTTED SPRING .062 X .250	58
-	1	1	1338685-1	PAWL, FEED	56
-	4	4	2168083-3	SCR, SKT HD CAP, RoHS, M4 X 12.0	54
-	2	2	2168083-3	SCR, SKT HD CAP, RoHS, M4 X 12.0	53
-	1	1	1803382-2	HOLD DOWN, SPRING LOADED	50
-	1	1	18023-9	SCR, SKT HD CAP M4 X 6.0	49
-	1	1	1803583-9	APPLICATOR BASIC ASSEMBLY, SF	46
-	1	1	1803515-1	RAM ASSEMBLY, SF ATLANTIC	44
-	1	1	1803602-1	SCR, BHSC, RoHS (M8 X 25)	41
-	1	1	1-1752356-1	SUPPORT, TERMINAL	34
-	2	2	2079383-5	SCR, BHSC, RoHS (M4 X 20)	33
-	2	2	3-2844962-0	SPACER, CYLINDRICAL, STRIP GUIDE	30
-	1	1	2844992-2	ASSEMBLY, STRIP GUIDE	29
-	1	1	1-455888-0	SPACER, CRIMPER	28
-	1	1	1320928-6	STRIP GUIDE	24
-	1	1	2168083-2	SCR, SKT HD CAP, RoHS, M4 X 8.0	21
-	1	1	1-18028-2	WASHER, FLAT, REG M4	20
-	1	1	2119533-1	STRIPPER, SIDE FEED	19
-	1	1	2119806-1	INSERT, SHEAR	13
-	1	1	3-22280-3	SPRING, COMPRESSION	12
-	1	1	1-356885-4	STOP, SHEAR	11
-	1	1	2119805-1	SHEAR HOLDER, FRONT	10
-	1	1	454276-5	FLOATING SHEAR, FRONT	9
-	1	2	1333207-2	ANVIL, COMBINATION .110	8
-	1	1	240641-2	SPACER	7
-	1	1	2119780-9	DEPRESSOR, SHEAR	5
-	1	1	1-238011-7	BLOCK, CRIMPER SPACER	4
-	1	2	2119785-6	CRIMPER, INSULATION OVERLAP PREMIUM	3
-	1	2	2-456408-0	CRIMPER, WIRE PREMIUM	1

DIMENSIONS:		TOLERANCES UNLESS OTHERWISE SPECIFIED:		MATERIAL:		FINISH:	
mm	0 PLC ±	1 PLC ±	2 PLC ±	3 PLC ±	4 PLC ±	ANGLES ±	

OWN	B. WEAVER	19AUG2011
CHK	G. HOFENER	19AUG2011
APVD	T. ELBIN	19AUG2011
NAME	Ocean Side Feed Applicator	
SIZE	CAGE CODE	DRAWING NO
A1	00779	2151160
Customer Accessible Production Drawing		SCALE 1:2 SHEET 1 OF 4 REV D

ATLANTIC VERSION
Shown on sheets 1 of 4 & 2 of 4
(Pacific version shown on sheets 3 of 4 & 4 of 4)

LOC	DIST	REV	DATE	BY	APPV
A	66				

REVISIONS			
REV	DATE	DESCRIPTION	BY
-	-	SEE SHEET 1	-

FEED TYPE

PNEUMATIC

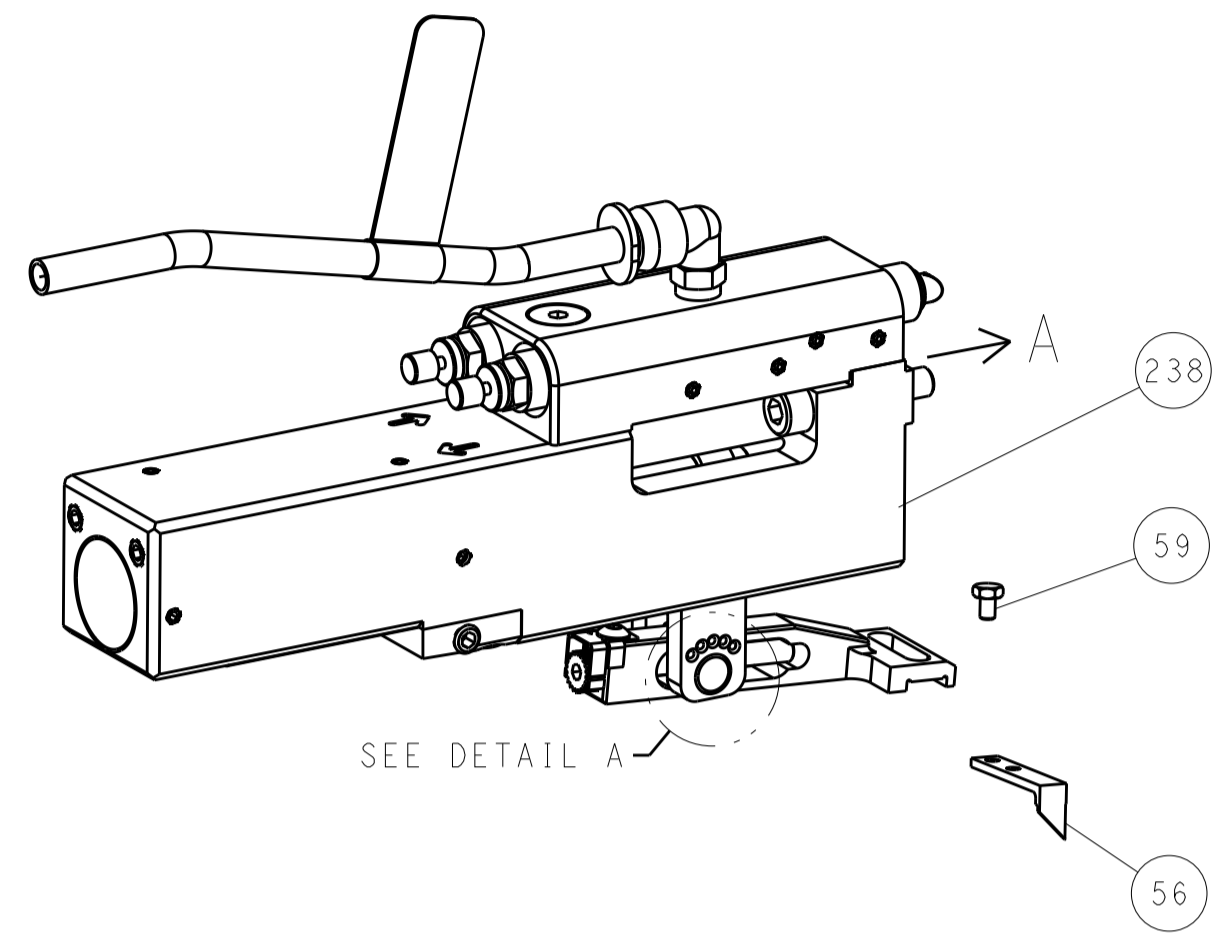

SEE DETAIL A
 FEED SPRING SETTING POSITION
 (SHOWN FROM REAR SIDE)

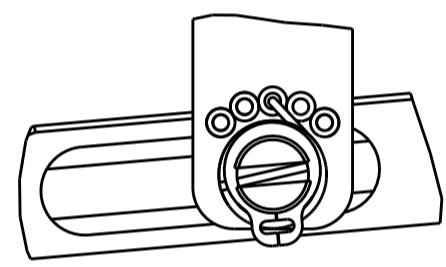

DETAIL A

CAM POSITION

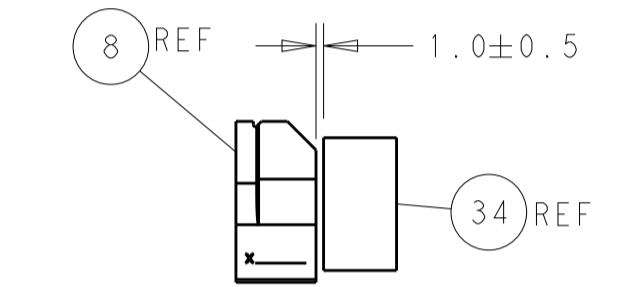
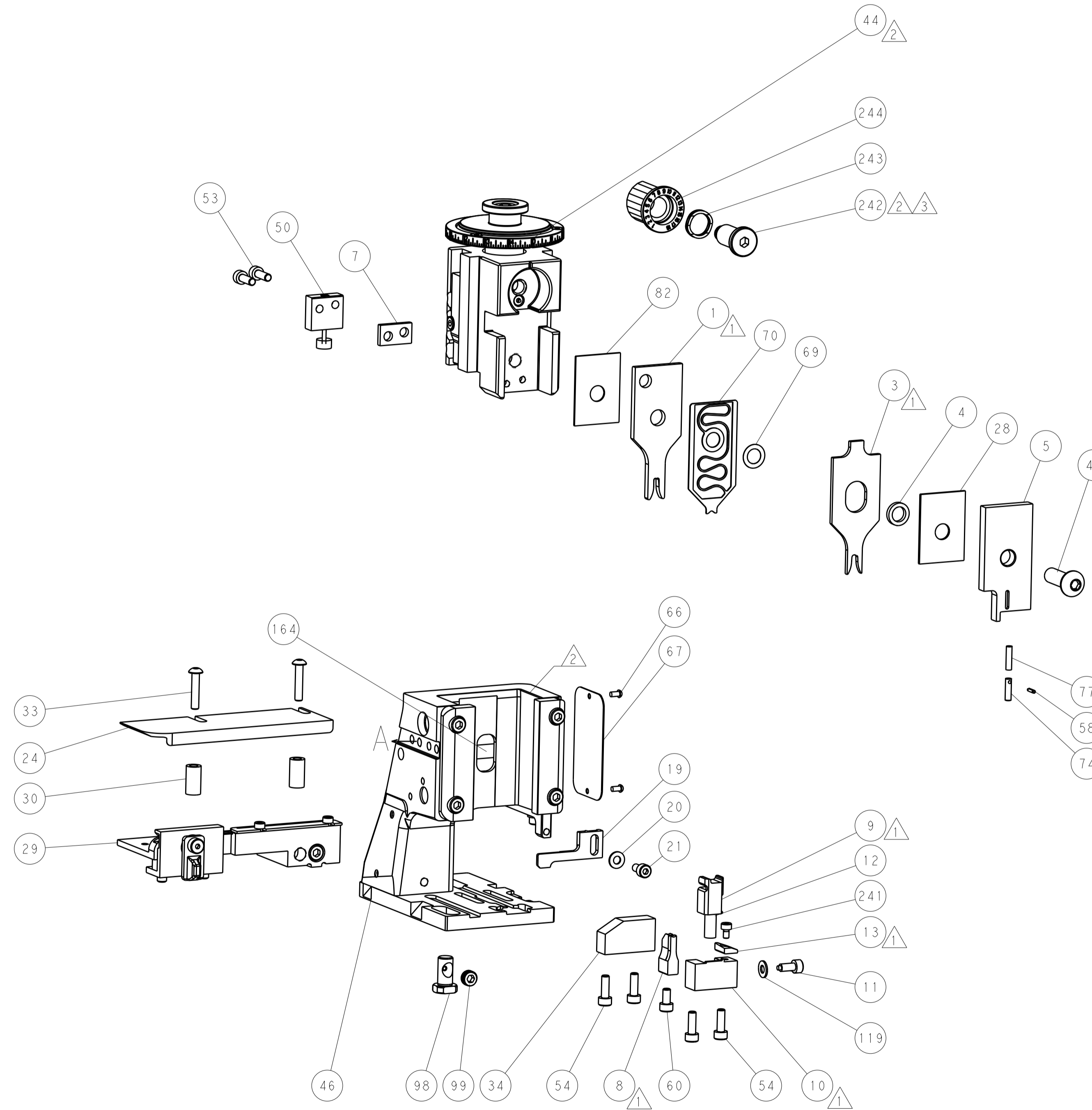
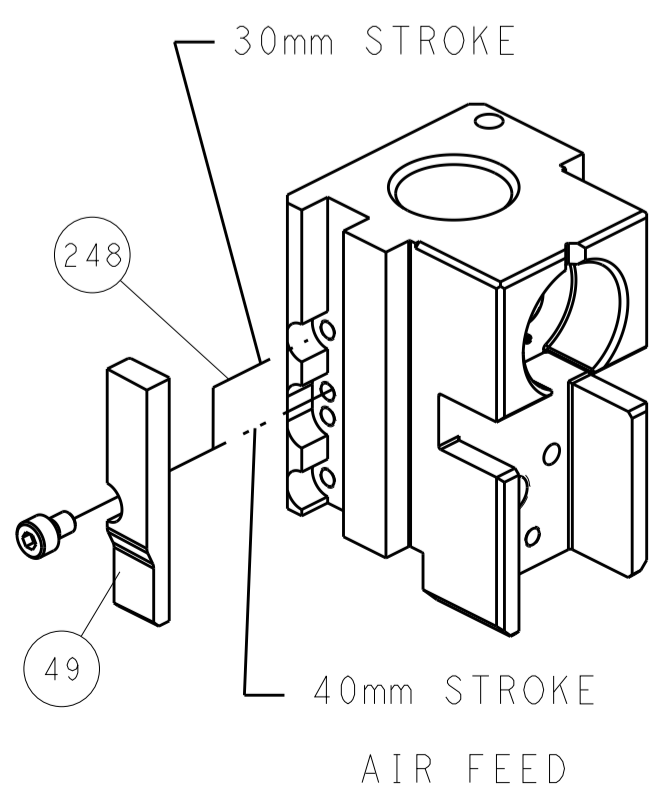

TERMINAL SUPPORT LOCATION

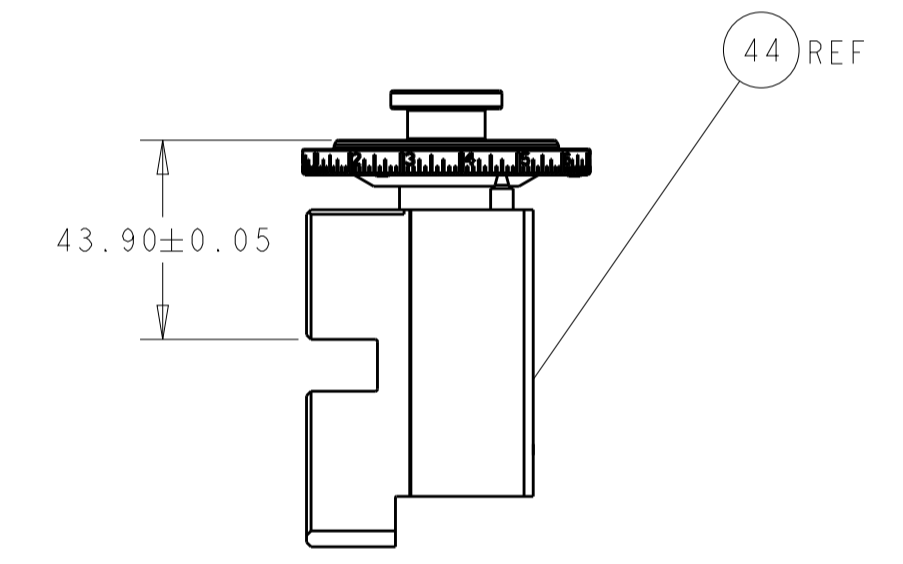

RAM SET-UP

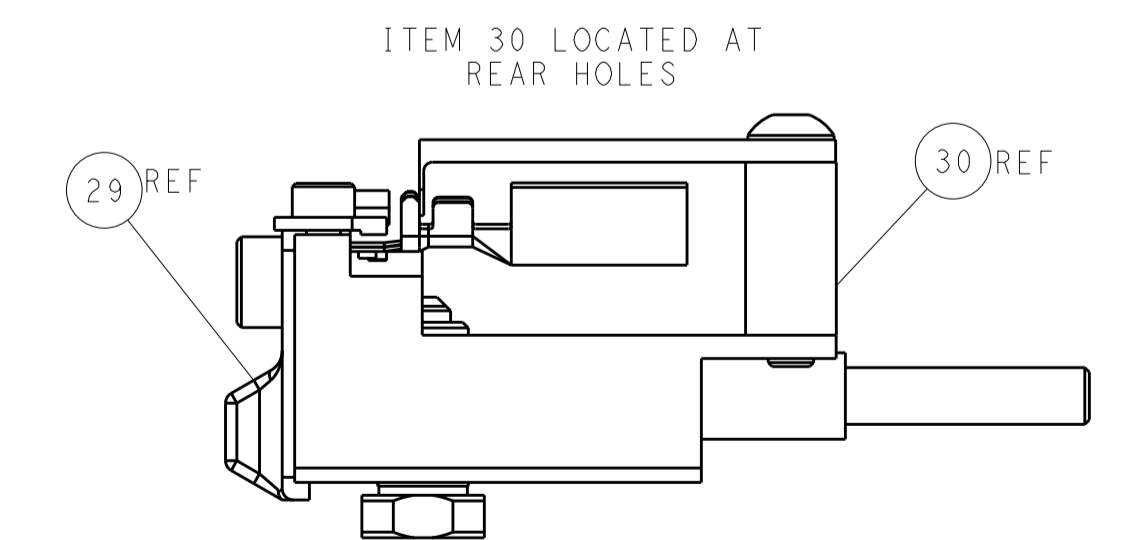

FEED TRACK POSITION
 GUIDE BY INSULATION BARREL

ATLANTIC VERSION
 Shown on sheets 1 of 4 & 2 of 4
 (Pacific version shown on sheets 3 of 4 & 4 of 4)

<small>THIS DRAWING IS UNPUBLISHED. RELEASED FOR PUBLICATION 2011. IT IS THE PROPERTY OF TYCO ELECTRONICS CORPORATION. IT IS TO BE USED ONLY FOR THE PURPOSES AND IN THE QUANTITIES SPECIFIED IN THE ORDER. ANY OTHER USE OR REPRODUCTION WITHOUT THE WRITTEN PERMISSION OF TYCO ELECTRONICS CORPORATION IS STRICTLY PROHIBITED.</small>		DWN: B. WEAVER 19AUG2011 CHK: G. HOFFNER 19AUG2011 APVD: T. ELBIN 19AUG2011	TE Connectivity Harrisburg, PA 17105-3608
DIMENSIONS: mm TOLERANCES UNLESS OTHERWISE SPECIFIED: 0 PLC ± 1 PLC ± 2 PLC ± 3 PLC ± 4 PLC ± ANGLES ±		NAME: Ocean Side Feed Applicator PRODUCT SPEC: APPLICATION SPEC: SIZE: A1 CAGE CODE: 00779 DRAWING NO: 2151160	RESTRICTED TO:
MATERIAL:		WEIGHT:	SCALE: 1:2 SHEET: 2 of 4 REV: D

PART NUMBER	REVISION	DESCRIPTION	FEED TYPE
2-2151160-2	D	FINE CRIMP HEIGHT ADJUST	PNEUMATIC
7-2151160-7	B	CRIMP TOOLING KIT	-

PACIFIC VERSION TERMINATOR
INTERFACE ADAPTER

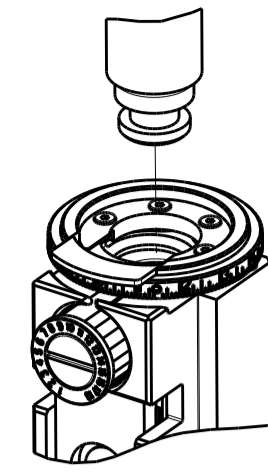

APPLICATOR DATA		
CRIMP	SIZE	TYPE
WIRE	2.79 mm [.110]	F
INSUL	3.56 mm [.140]	OV
APPLICATOR INSTRUCTIONS 408-35042		

TERMINAL DATA: TE TERMINAL		TE CRIMP SPECIFICATION	
TERMINAL NAME: TAB 5.8 x 0.8			
WIRE STRIP LENGTH 4.10-4.12 mm [.161-.162 IN]		INSULATION DIAMETER RANGE Ø2.20-3.00 mm [.087-.118 IN]	
TERMINAL APPLICATION SPECIFICATION 114-18052			
TERMINALS APPLIED			
TE TERMINAL	TE TERMINAL	TE TERMINAL	TE TERMINAL
964306-1	964306-3		

WIRE SIZE	CRIMP HEIGHT mm [INCH]	CRIMP HEIGHT REFERENCE SETTING
2.50mm ²	1.97+/-0.05 [.078+/- .002]	5.4
(2)1.0mm ² OR (1)2.0mm ²	1.83+/-0.05 [.072+/- .002]	7.0
(1)1.5mm ² + (1)0.35mm ²	1.79+/-0.05 [.070+/- .002]	7.5
1.50mm ²	1.69+/-0.05 [.067+/- .002]	8.4

- RECOMMENDED SPARE PARTS
- REFER TO SUPPLIED INSTRUCTION SHEET FOR CLEANING, LUBRICATION AND STORAGE OF APPLICATOR.
- APPLY PART NUMBER 2-23419-6 LOCTITE TO THREADS OF ITEM 242.
- CRIMP HEIGHT REFERENCE SETTING WAS THE SETTING USED WHEN THE APPLICATOR WAS QUALIFIED AT THE FACTORY. ADJUSTMENT MAY BE NECESSARY WHEN RUNNING APPLICATOR IN THE FIELD.
- TERMINAL PITCH NOT COMPATIBLE WITH MECHANICAL FEED.
- 6. UNLESS SPECIFIED OTHERWISE TORQUE VALUES SHALL BE USED PER DOCUMENT, 101-35000.

***WARNING**
ON INSTALLATION, SET WIRE DISC TO CRIMP HEIGHT REFERENCE SETTING FOR LARGEST WIRE SIZE. CRIMP HEIGHT REFERENCE SETTINGS GREATER THAN THE VALUE SHOWN MAY CAUSE DAMAGE TO THE CRIMP TOOLING. REFER TO THE INSTRUCTION SHEET FOR PROPER SETUP AND ADJUSTMENTS.

LOC	DIST	REV	DATE	BY	APPV
A	66				

REVISIONS					
REV	DATE	DESCRIPTION	DATE	BY	APPV
-	-	SEE SHEET 1	-	-	-
-	1	2119082-9			244
-	1	2079764-1			243
-	1	2119083-1			242
-	1	18023-1			241
-	1	2844940-1			238
-	REF	994970-2			164
-	1	2119641-2			151
-	1	2168083-8			144
-	4	2168083-9			143
-	1	1-1803583-0			141
-	1	1803516-1			140
-	1	18028-2			119
-	1	2844908-1			99
-	1	2844907-1			98
-	1	455888-7			82
-	1	1-22278-0			77
-	1	854769-4			74
-	1	1803607-3			71
-	1	2119791-5			70
-	1	2119943-1			69
-	1	2119740-1			67
-	2	2168078-1			66
-	1	5-18022-5			59
-	1	21028-2			58
-	1	1338685-1			56
-	2	2168083-3			53
-	1	1803382-2			50
-	1	18023-9			49
-	1	1803602-1			41
-	1	1-1752356-1			34
-	2	2079383-5			33
-	2	3-2844962-0			30
-	1	2844992-2			29
-	1	1-455888-0			28
-	1	1320928-6			24
-	1	2168083-2			21
-	1	1-18028-2			20
-	1	2119533-1			19
-	1	2119806-1			13
-	1	3-22280-3			12
-	1	1-356885-4			11
-	1	2119805-1			10
-	1	454276-5			9
-	1	1333207-2			8
-	1	240641-2			7
-	1	2119780-9			5
-	1	1-238011-7			4
-	1	2119785-6			3
-	1	2-456408-0			1
-77	-22	PART NO			ITEM NO

PACIFIC VERSION
Shown on sheets 3 of 4 & 4 of 4
(Atlantic version shown on sheets 1 of 4 & 2 of 4)

DIMENSIONS:		TOLERANCES UNLESS OTHERWISE SPECIFIED:		DWG: B. WEAVER 19AUG2011		CHK: G. HOFENER 19AUG2011		APVD: T. ELBIN 19AUG2011		NAME: Ocean Side Feed Applicator	
mm	0 PLC ±	1 PLC ±	2 PLC ±	3 PLC ±	4 PLC ±	ANGLES	FINISH	WEIGHT	SCALE: 1:2	SHEET 3 OF 4	REV D
MATERIAL:		FINISH:		CUSTOMER ACCESSIBLE PRODUCTION DRAWING		SCALE: 1:2		SHEET 3 OF 4		REV D	

LOC		DIST		REVISIONS			
A	66	P	LTM	DESCRIPTION	DATE	OWN	APVD
		-		SEE SHEET 1			

FEED TYPE

PNEUMATIC

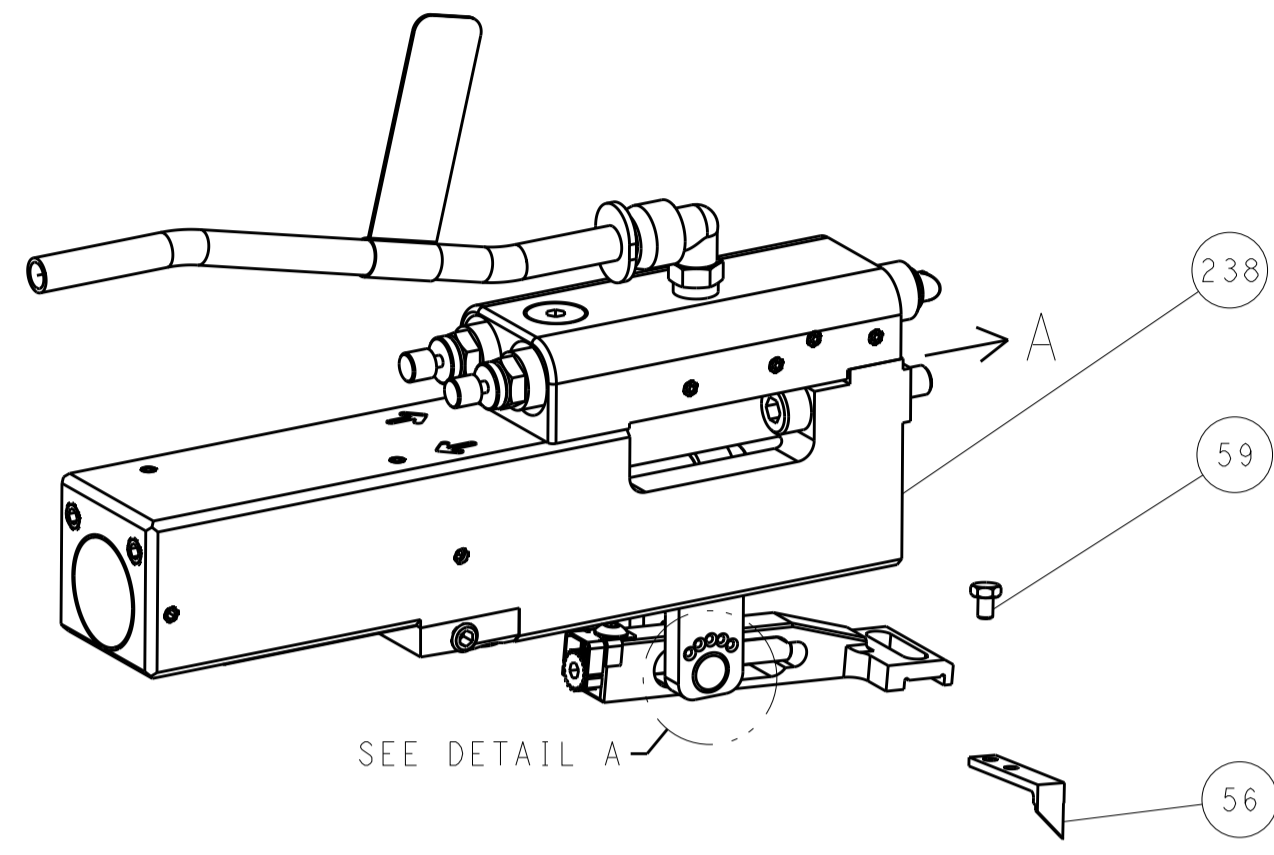

FEED SPRING SETTING POSITION
(SHOWN FROM REAR SIDE)

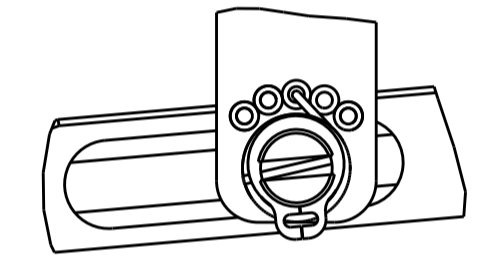

DETAIL A

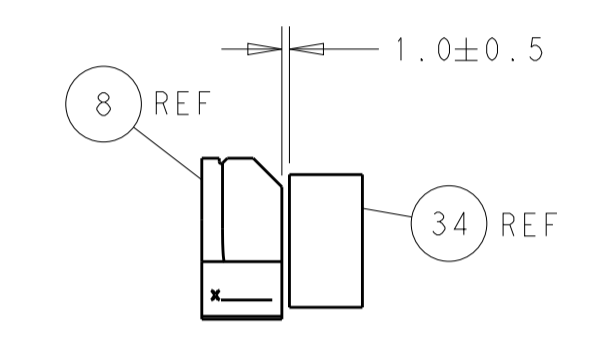
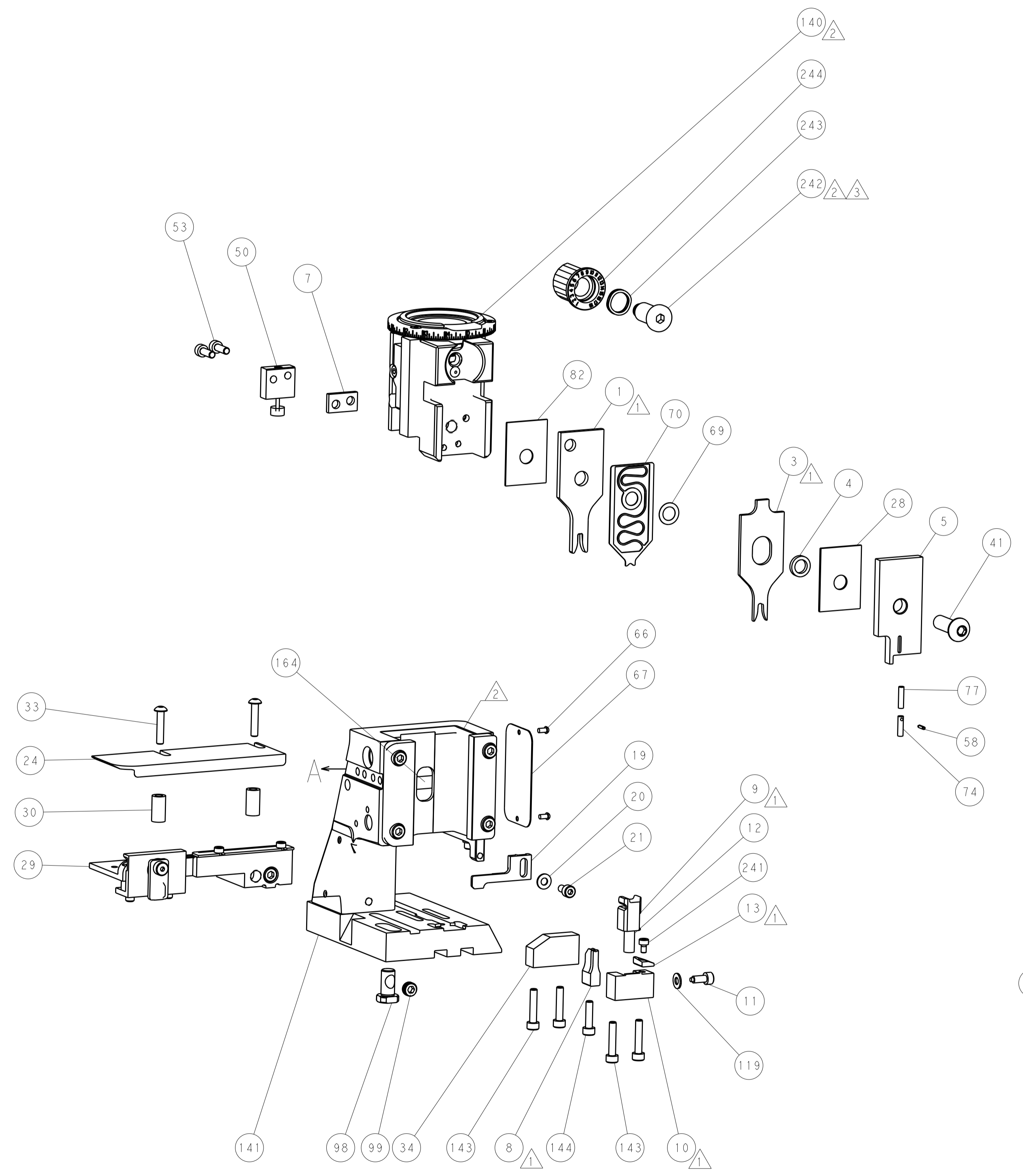

TERMINAL SUPPORT LOCATION

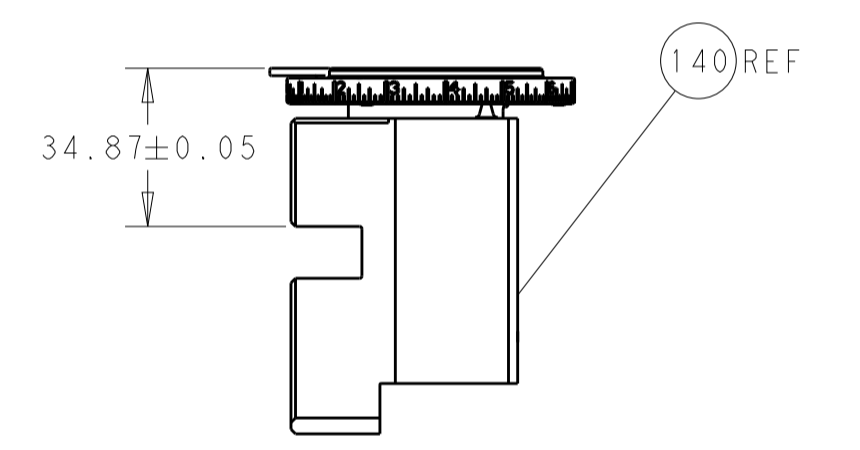

RAM SET-UP

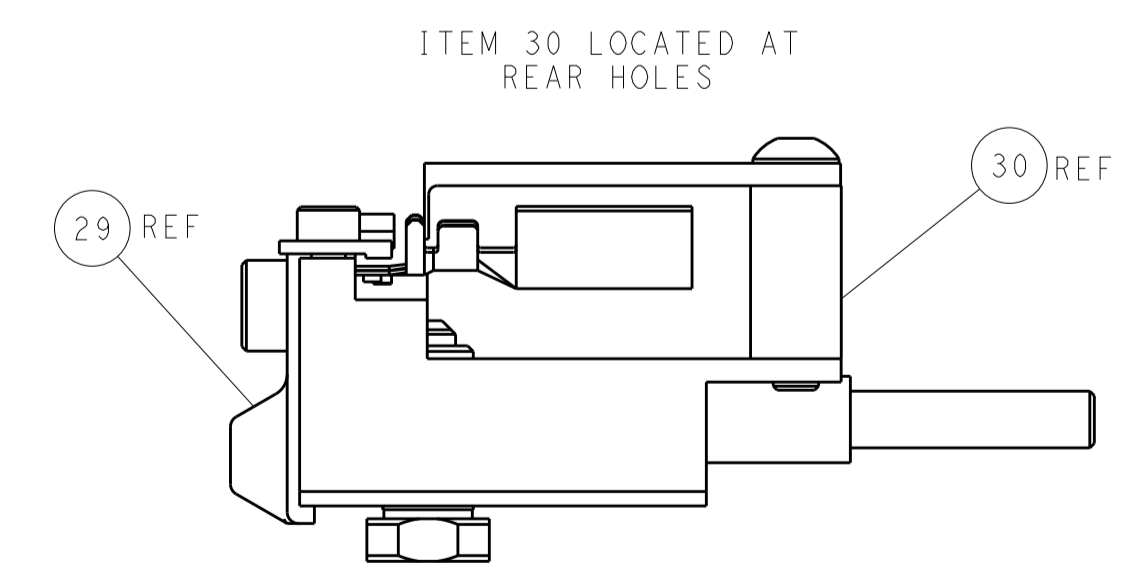

FEED TRACK POSITION
GUIDE BY INSULATION BARREL

CAM POSITION

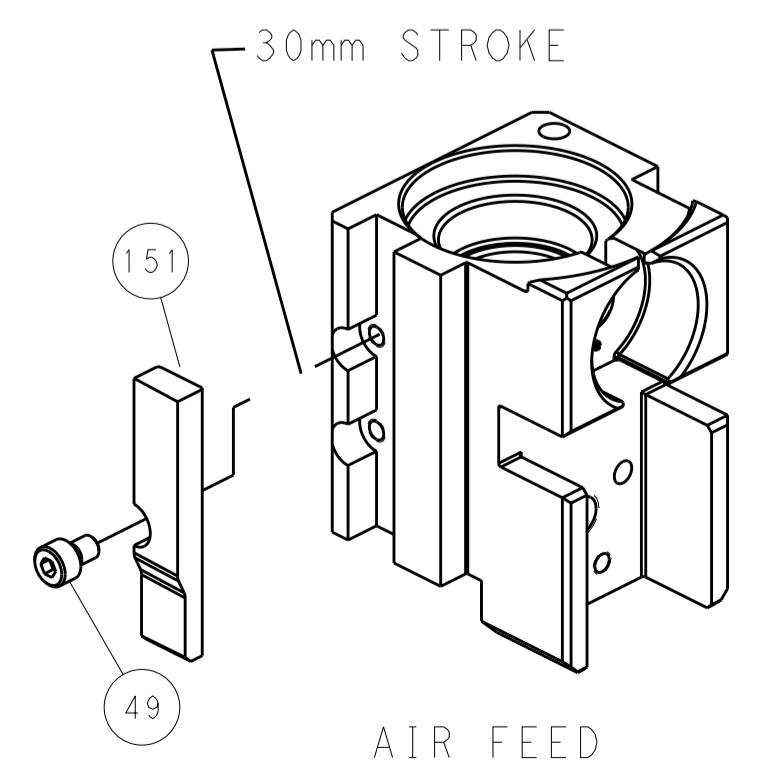

AIR FEED

PACIFIC VERSION
 Shown on sheets 3 of 4 & 4 of 4
 (Atlantic version shown on sheets 1 of 4 & 2 of 4)

DIMENSIONS:		TOLERANCES UNLESS OTHERWISE SPECIFIED:		DWG: B. WEAVER 19AUG2011		TE Connectivity	
mm	0 PLC	±		CHK: G. HOFFNER 19AUG2011	NAME: Ocean Side Feed Applicator		Harrisburg, PA 17105-3608
	1 PLC	±		APVD: T. ELBIN 19AUG2011	PRODUCT SPEC:		
	2 PLC	±			APPLICATION SPEC:		
	3 PLC	±			SIZE: CAGE CODE: DRAWING NO:		RESTRICTED TO:
	4 PLC	±			A1 00779 ©=2151160		
MATERIAL:	FINISH:	WEIGHT:	SCALE:	Customer Accessible Production Drawing		SHEET 4 OF 4	REV D