

RF CHARACTERISTICS

Frequency range : **0 - 18 GHz**
Impedance : **50 Ohms**

| Frequency (GHz) | DC - 3 | 3 - 8 | 8 - 12.4 | 12.4 - 18 |
|--------------------|----------------|----------------|----------------|----------------|
| VSWR max | 1.20 | 1.30 | 1.40 | 1.50 |
| Insertion loss max | 0.20 dB | 0.30 dB | 0.40 dB | 0.50 dB |
| Isolation min | 80 dB | 70 dB | 65 dB | 60 dB |
| Average power (*) | 240 W | 150 W | 120 W | 100 W |

ELECTRICAL CHARACTERISTICS

Actuator : **LATCHING**
Nominal current ** : **320 mA**
Actuator voltage (Vcc) : **12V (10.2 to 13V) / POSITIVE COMMON**
Terminals : **solder pins (250°C max. / 30 sec.)**
Self cut-off time : **40 ms < CT < 120 ms**

MECHANICAL CHARACTERISTICS

Connectors : **SMA female per MIL-C 39012**
Life : **2.5 million cycles**
Switching Time*** : **< 15 ms**
Construction : **Splashproof**
Weight : **< 100 g**

ENVIRONMENTAL CHARACTERISTICS

Operating temperature range : **-40°C to +85°C**
Storage temperature range : **-55°C to +85°C**

(* Average power at 25°C per RF Path)

(** At 25° C ±10%)

(*** Nominal voltage ; 25° C)



PAGE 2/2

ISSUE 22-03-22

SERIE : DPDT

PART NUMBER : R577452010

DRAWING

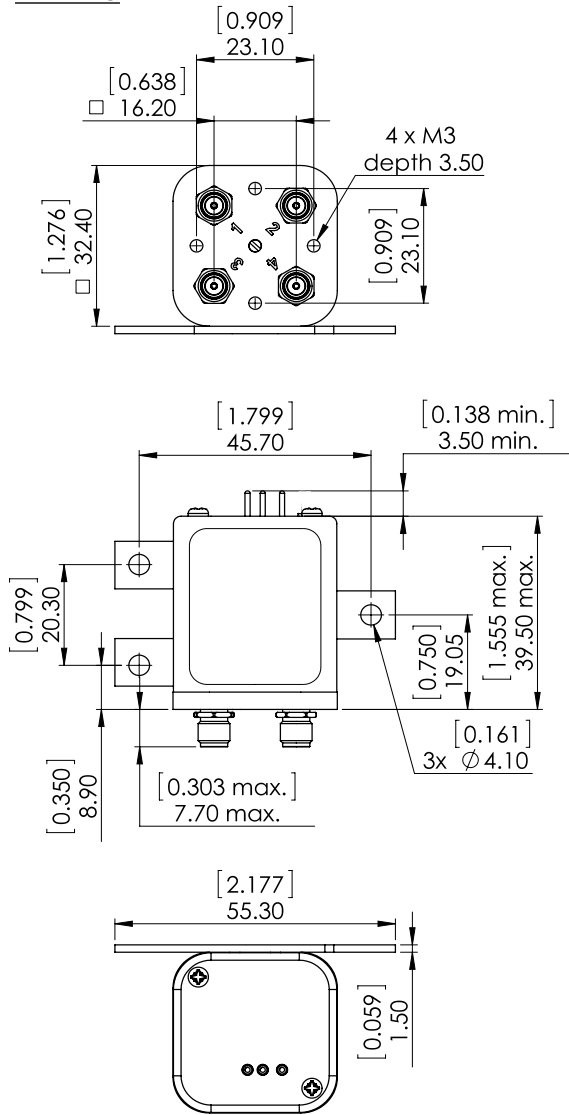

General tolerances : ±0,5 mm [0,02 in]

SCHEMATIC DIAGRAM

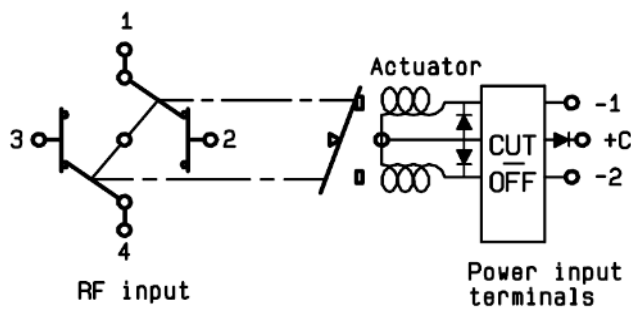

| Voltage | RF Continuity |
|---------|---------------|
| +C -1 | 1 ↔ 3 / 2 ↔ 4 |
| +C -2 | 1 ↔ 2 / 3 ↔ 4 |



LABEL

-1 -2 +C

RADIALL®
 R577452010
 0 - 18 GHz
 Un : 12V
 Lot : _____