

Material :

- * Base: High temperature plastic UL 94V-0, Color Nature
- * Cover: High temperature plastic UL 94V-0, Color Black
- * Contact: Phosphor Bronze
- * Fixed tab: Phosphor Bronze with 2.50um(100u'') Min. Matte Tin Plated over 1.27um(50u'') Min.Nickel

Ordering Code

CF35 ** * D 0 RM -NH
 ① ② ③ ④ ⑤ ⑥ ⑦

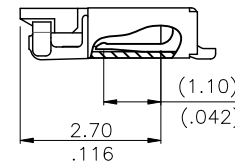
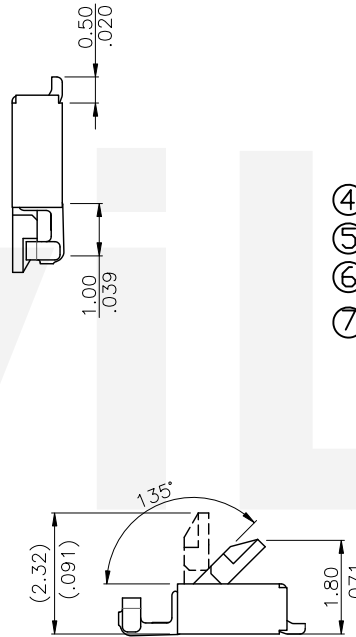
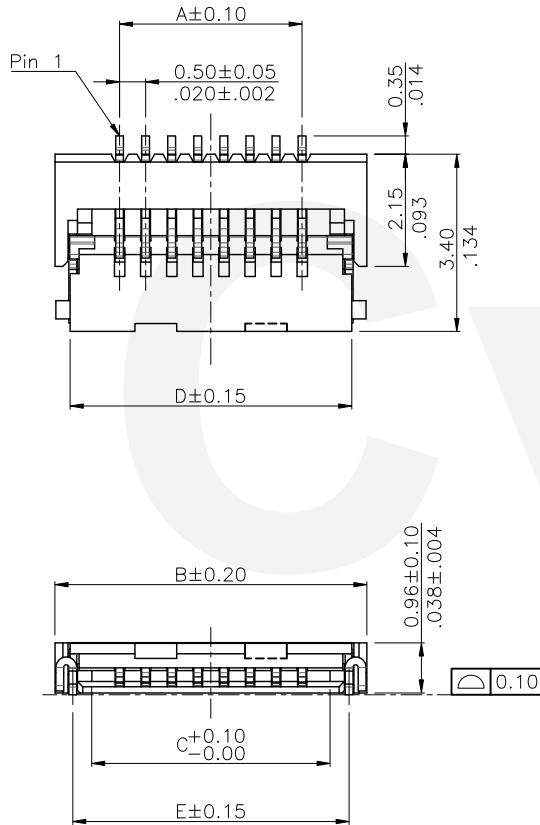
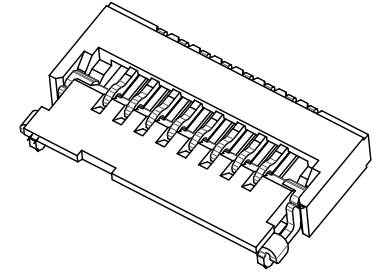

- ① Series No.
 - ② No. of Circuits 4~30PIN
 - ③ Plating code:
 - 1= 80u''~120u''Matte Tin plated over , 50u''~80u''Min.Nicke.
 - 2= 0.03um(1.2u'') Min.Gold Flash, 50u''~80u'' MIN Nickel Underplating.
 - F= 0.03um(1.2u'') Min.Gold Flash on Contact area and Solder tails, 1.27um(50u'') Min. Nickel Underplating over all.
 - ④ Contact style: D= Downside contact
 - ⑤ 0= Color Nature
 - ⑥ Packing: RM= Tape & Reel packing
 - ⑦ -NH= For Lead Free IR Processed and Halogen Free
- DIM A=0.5 X (No. of Circuits-1)
 DIM B=DIM A+2.50
 DIM C=DIM A+1.10
 DIM D=DIM A+1.90
 DIM E=DIM A+1.80

Halogen-Free Lead Free Process RoHS Compliant

④					DATE	UNIT: mm / inch	TITLE: 0.50mm(.020'') ZIF FFC/FPC ONE-TOUCH CONNECTOR
③					5/11-20'	TOLERANCE UNLESS OTHERWISE SPECIFIED	MATERIAL:
②					5/11-20'	.X ± 0.20/.008 .X' ±	
①					5/11-20'	.XX ± 0.15/.006 .X' ± 1'	FINISH:
SYM	NAME	DATE	REVISIONS	APPROVED BY:	5/11-20'	.XXX ± .XX' ±	

CVILUX
2020.05.28
ISSUED

瀚荃股份有限公司
CviLux Corporation

DRAWING NO.	CF3527SA	PART NO.	CF35***DORM-NH
SCALE	1 / 1	SHEET	1 OF 3

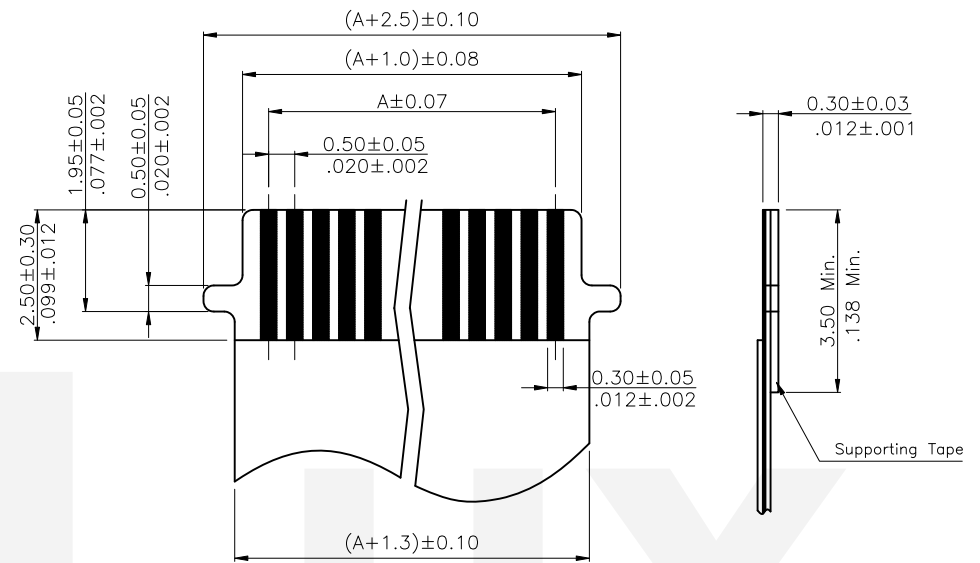
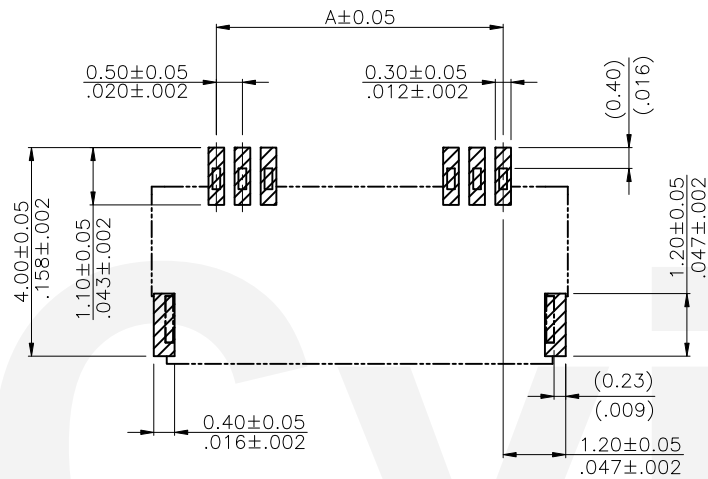

Recommended P.C. Board Layout

Accommodated FFC/FPC

Halogen-Free

Lead Free Process

RoHS Compliant

4					DATE	UNIT: mm / inch	TITLE: 0.50mm(.020") ZIF FFC/FPC ONE-TOUCH CONNECTOR	 瀚荃股份有限公司 CviLux Corporation	
3				DRAWN BY: Hero	5/11-20'	TOLERANCE UNLESS OTHERWISE SPECIFIED	MATERIAL:		
2				ENGINEER: Hero	5/11-20'	.X ± 0.20/.008 X' ±	FINISH:	DRAWING NO. CF3527SA	PART NO. CF35***DORM-NH
1				CHECKED BY: Steve	5/11-20'	.XX ± 0.15/.006 X' ± 1'		SCALE 1 / 1	SHEET 2 OF 3
SYM	NAME	DATE	REVISIONS	APPROVED BY: Phil	5/11-20'	.XXX ±			

CVILUX
 2020.05.28
 ISSUED

Notes:

1. Reel Material : HIPS
2. 10 sprocket hole pitch cumulative tolerance ± 0.2
3. Camber not to exceed 1mm in 100mm.
4. Material: Polystyrene.
5. Pocket position relative to sprocket hole measured as true position of pocket, not pocked hole.
6. All dimensions meet EIA-481-B requirements.
7. Quantity: 3000 PCS/REEL

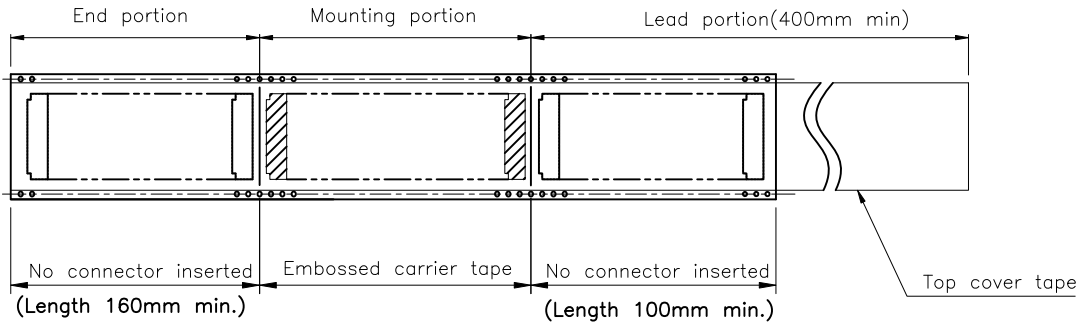

TAPE RUNNING DIRECTION

Circuits	Dimension					Packing (Reel/Caton)
	E	F	W1	W2	W3	
4-11	16.0(.630)	7.50(.295)	16.5(.650)	22.5(.885)	16.5(.650)	11
12-29	24.0(.945)	11.50(.453)	24.5(.965)	30.5(1.200)	24.5(.965)	9
30	32.0(1.260)	14.20(.559)	32.5(1.280)	38.5(1.516)	32.5(1.280)	7

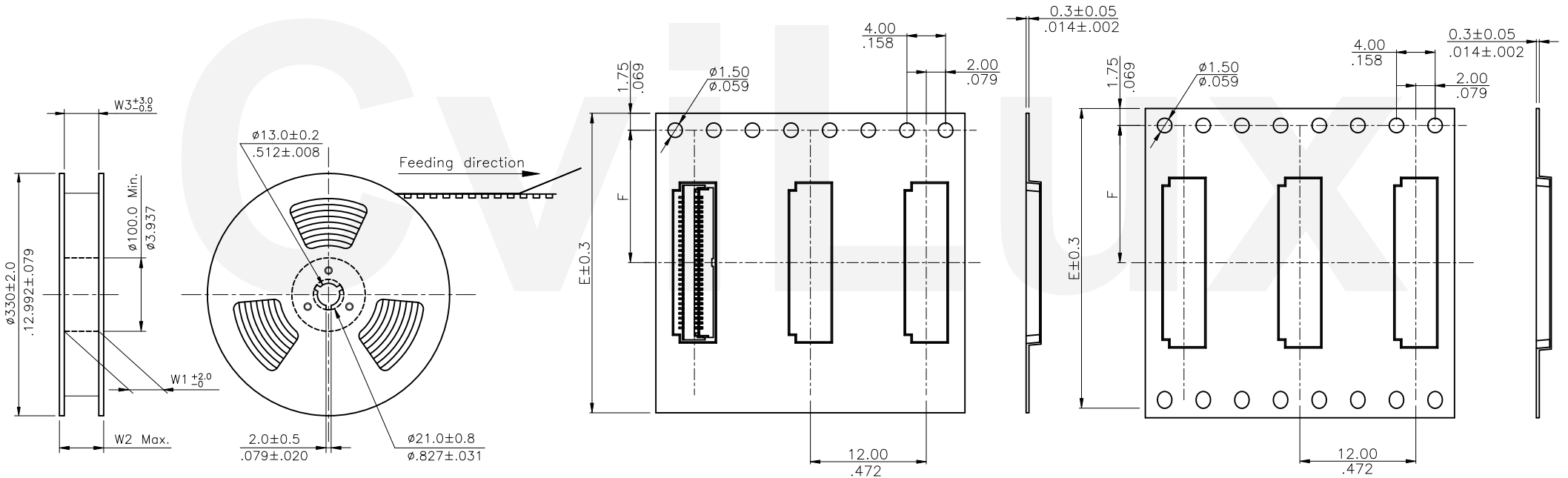

WIDTH : 16,24 mm Carrier
(SCALE 1:4)

WIDTH : 32,44 mm Carrier
(SCALE 1:4)

RoHS Compliant

4	3	2	1	SYM	NAME	DATE	REVISIONS	APPROVED BY:	Phil	5/11-20'	UNIT: mm / inch	TITLE: 0.50mm(.020") ZIF FFC/FPC ONE-TOUCH CONNECTOR	 瀚荃股份有限公司 CviLux Corporation			
								DRAWN BY:	Hero	5/11-20'	TOLERANCE UNLESS OTHERWISE SPECIFIED	MATERIAL:	DRAWING NO.	CF3527SA	PART NO.	CF35***DORM-NH
								ENGINEER:	Hero	5/11-20'			.X \pm 0.15/.006	.X' \pm	SCALE	1 / 1
								CHECKED BY:	Steve	5/11-20'	.XX \pm 0.10/.004	.X' \pm 1'				
										5/11-20'	.XXX \pm	.XX' \pm				

CVILUX
2020.05.28
ISSUED