



# AK9754

## Ultra-small IR Sensor IC with I<sup>2</sup>C I/F

### 1. General Description

The AK9754 is an ultra-low power and ultra-small quantum infrared-ray (IR) sensor module with signal processing circuits and Human Approach Detection algorithm. It can detect a human approach and outputs a signal from interrupt pins. An integral analog-to-digital converter provides 16-bits data outputs. Human detection can be easily realized by using built-in Human Approach Detection algorithm. The AK9754 is suitable for human sensing application.

### 2. Features

- Quantum-type IR Sensor
- Integrated Temperature Sensor:     -30 to 85°C Output on I<sup>2</sup>C bus
- 16-bits Digital Outputs to I<sup>2</sup>C Bus
- Integrated Digital Filters:
  - IR Sensor:                     Cut-off Frequency 0.9Hz, 0.445Hz
  - Temperature Sensor:         Cut-off Frequency 0.9Hz, 0.445Hz
  - \* Only with 10Hz of Data Output Rate(ODR)
- I<sup>2</sup>C Interface:
  - Support Standard mode(100Hz) and Fast modes(400Hz).
  - \*Pull-up resistors must be connected to the same level as the power supply of the AK9754.
- Multiple Synchronization Connection:
  - Eight devices can be connected in synchronization at maximum, and setting I<sup>2</sup>C bus slave addresses for each.
- Interrupt Function:
  - INTN pin goes to active when detecting a human approach or measurement data is ready to be read.
- Power Supply:                             1.71 to 3.63V
- Low Consumption Current:
  - 10 μA (Max.)     10Hz of Data Output Rate (Low-noise Mode OFF)
  - 5 μA (Typ.)     10Hz of Data Output Rate (Low-noise Mode OFF)
  - \*TOPT[1:0] = 11B
- Ultra-small and Thin Package:         8-pin SON  
2.2mm x 2.2mm x t0.6mm

<b>3. Table of Contents</b>
-----------------------------

1. General Description.....	1
2. Features .....	1
3. Table of Contents .....	2
4. Block Diagram and Functions .....	3
4.1. Block Diagram .....	3
4.2. Functions .....	3
5. Pin Configurations and Functions .....	4
5.1. Pin Configurations .....	4
5.2. Functions .....	4
6. Absolute Maximum Ratings.....	5
7. Recommended Operating Conditions.....	5
8. Power Supply Conditions .....	5
9. Electrical Characteristics .....	6
9.1. Total Characteristics .....	6
9.2. Digital Characteristics.....	6
9.2.1. DC Characteristics .....	6
9.2.2. AC Characteristics (1): Standard Mode (100 kHz) .....	7
9.2.3. AC Characteristics (2): Fast Mode (400 kHz) .....	7
9.2.4. AC Characteristics (3): INTN .....	8
10. Functional Descriptions .....	9
10.1. Power Supply States .....	9
10.2. Reset functions .....	9
10.3. Operation Mode .....	10
10.4. Operation Modes .....	11
10.4.1. Stand-by Mode (MODE = "0") .....	11
10.4.2. Continuous Mode (MODE = "1") .....	11
10.5. Synchronization Function .....	12
10.6. Sampling Data Storage Function .....	12
10.7. Measurement Data Read .....	13
10.8. Data Read Sequence Example .....	17
10.9. Internal Algorithm.....	19
11. Serial Interface.....	20
11.1. Data Transfer .....	20
11.1.1. Changing state of the SDA line .....	20
11.1.2. Start / Stop Conditions .....	20
11.1.3. Acknowledge .....	21
11.1.4. Slave Address .....	22
11.1.5. Write Command .....	22
11.1.6. Read Command .....	23
12. Memory Map .....	25
13. Register Definitions .....	26
14. Spectrum Sensitivity (Reference) .....	36
15. Field of View (Reference).....	37
16. IR Sensor Output Characteristics (Reference) .....	38
17. Recommended External Circuits .....	39
18. Package.....	40
18.1. Outline Dimensions .....	40
18.2. Pad dimensions .....	41
18.3. Marking .....	42
19. Ordering Guide.....	42
20. Revision History .....	42
IMPORTANT NOTICE .....	43

**4. Block Diagram and Functions**

**4.1. Block Diagram**

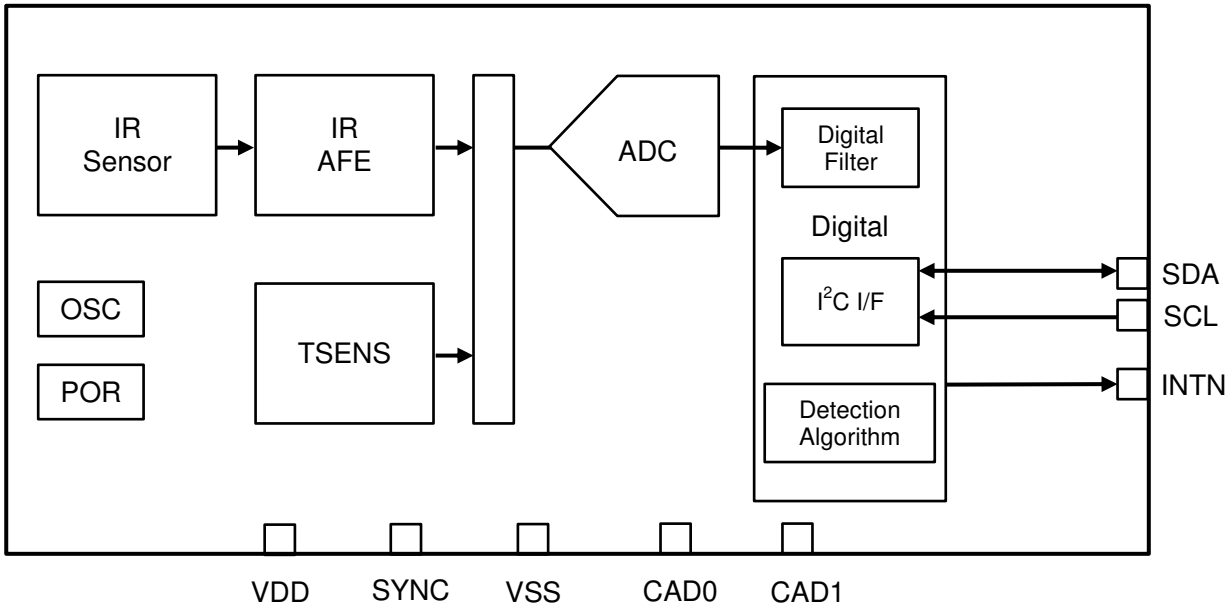

Figure 4.1. AK9754 Block Diagram

**4.2. Functions**

Table 4.1. Functions

Block	Function
IR Sensor	IR Sensor Element.
OSC	Built-in Oscillator.
TSENS	Built-in Temperature Sensor.
IR AFE	Convert current from the IR sensor element into voltage signal. Cancel offset of the sensor signal.
ADC	Convert analog outputs of IR AFE and TSENS into digital signals.
Digital Filter	Digital filter (LPF) for ADC output. Two types of cut-off frequencies (Fc) are selectable for IR sensor and built-in temperature sensor. In addition, it is possible to bypass this filter.
Detection Algorithm	Human Approach Detection algorithm is executed.
I <sup>2</sup> C I/F	Interface to external host MCU. The SCL and SDA pins are available for I <sup>2</sup> C interface. Support Standard Mode (100kHz) and Fast Mode (400kHz).
POR	Power-On Reset Circuit.

## 5. Pin Configurations and Functions

### 5.1. Pin Configurations

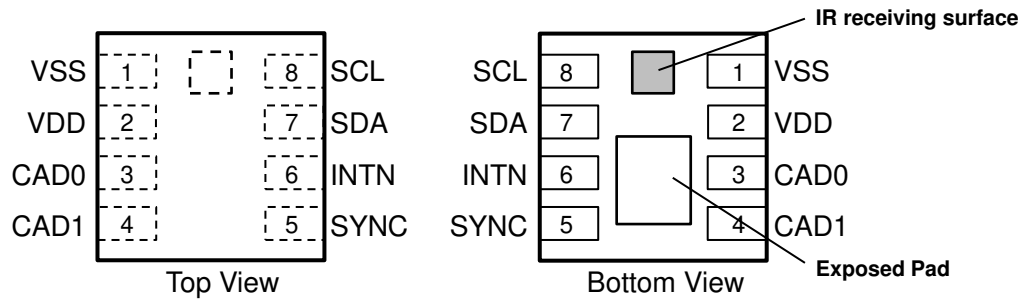

Note: The exposed pad is internally connected to the VSS pin.

Figure 5.1. Pin Configurations

### 5.2. Functions

Table 5.1 Functions

Pin No.	Pin Name	I/O	Function
1	VSS	-	GND Pin
2	VDD	-	Power Supply Pin
3	CAD0	I	Slave Address Input Pin A slave address is assigned by setting this pin non-connect or connecting to VDD or VSS. Make sure that there are no devices with the same slave address on the same data bus.
4	CAD1	I	Slave Address Input Pin A slave address is assigned by setting this pin non-connect or connecting to VDD or VSS. Make sure that there are no devices with the same slave address on the same data bus.
5	SYNC	I/O	Synchronize sampling timing between AK9754s. Please non-connect when SYNC pin is not used.
6	INTN	O	Interrupt Pin It goes to "L" in the following cases. (1) When detecting a human approach. (2) ADC output is ready to be read. The INTN pin is an open drain output (N-type transistor). This pin must be connected to the same level as the power supply of the AK9754 via a pull-up resistor.
7	SDA	I/O	I <sup>2</sup> C Data Input / Output Pin A bidirectional pin which is used to transmit data into and out of the device. It is composed of a signal input and an open drain output (N-type transistor). SDA pin is connected to the power supply line via a pull-up resistor.
8	SCL	I	I <sup>2</sup> C Clock Input Pin Signal processing is executed on a rising and falling edge of SCL clock. SCL pin is connected to the power supply line via a pull-up resistor.

**6. Absolute Maximum Ratings**

(VSS=0V)

Parameter		Symbol	Min.	Max.	Unit
Power Supply	VDD pin	VDD	-0.3	4.3	V
Input Current	All pins	lin	-10	10	mA
Output Current	All pins	lout	-10	10	mA
Input Voltage	SDA pin, SCL pin, INTN pin, CAD0 pin, CAD1 pin, SYNC pin	Vin	-0.3	4.3	V
Storage Temperature		Tst	-40	85	°C

WARNING: Operation at or beyond these limits may result in permanent damage to the device.  
Normal operation is not guaranteed at these extremes.

**7. Recommended Operating Conditions**

(VSS=0V)

Parameter	Symbol	Min.	Typ.	Max.	Unit
Power Supply	VDD	1.71	3.3	3.63	V
Operating Temperature	Ta	-30	25	85	°C

**8. Power Supply Conditions**

(Unless otherwise specified, VDD=1.71 to 3.63V, Ta= -30 to 85°C)

Parameter		Symbol	Min.	Typ.	Max.	Unit
Power Supply Rise Time (* 1, * 2)	Time until VDD is set to the operating voltage from 0.2V.	VDD pin			50	ms
Power-On Reset Time (* 1, * 2)	Time until AK9754 becomes Stand-by Mode after PSUP.	VDD pin			100	µs
Shutdown Voltage (* 2, * 3)	Shutdown Voltage for POR re-starting.	VDD pin			0.2	V
Power Supply Interval Time (* 1, * 2, * 3)	Voltage retention time below SDV for POR re-starting.	VDD pin	100			µs

Note:

- \* 1. Reference data only, not tested in production.
- \* 2. Power-On Reset circuit detects the rising edge of VDD, resets the internal circuit, and initializes the registers. After POR circuit works, AK9754 is set to Stand-by Mode.
- \* 3. Unless this condition is satisfied, the reset may not be correctly performed.

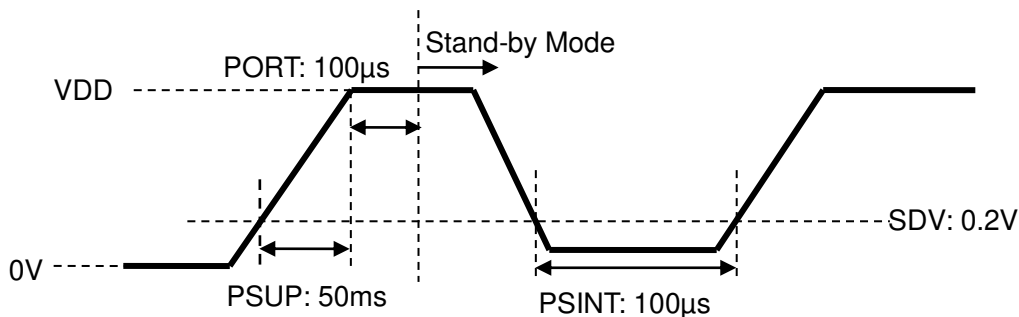

Figure 8.1. Power Supply Conditions

## 9. Electrical Characteristics

### 9.1. Total Characteristics

(VDD=1.71 to 3.63V, Ta= -30 to 85°C, unless otherwise specified , TYP: Ta = 25 °C VDD = 3.3V)

Parameter	Symbol	Min.	Typ.	Max.	Unit
IR output resolution			16		bit
Temperature sensor output resolution			16		bit
Temperature sensor output code *VDD = 3.3V	Ta = - 30 °C		-27726		Code
	Ta = 25 °C	-1515	0	1515	
	Ta = 85 °C		30247		
Temperature sensor resolution			0.00198		°C/ Code
Average Current Consumption Low-Noise Mode ON Ta ≤ 35°C TOPT[1:0] = 11B	Stand-by Mode	IDD0	1.1	3.0	μA
	Continuous Mode (ODR = 10Hz)	IDD1	35.0	100.0	μA
Average Current Consumption Low-Noise Mode OFF Ta ≤ 35°C TOPT[1:0]=11B	Stand-by Mode	IDD2	1.1	3.0	μA
	Continuous Mode (ODR = 10Hz)	IDD3	5.0	10.0	μA

### 9.2. Digital Characteristics

#### 9.2.1. DC Characteristics

(VDD=1.71 to 3.63V, Ta= -30 to 85°C, unless otherwise specified)

Parameter	Symbol	Min.	Typ.	Max.	Unit
High level input Voltage	SCL pin, SDA pin	VIH	70%VDD		V
Low level input Voltage	SCL pin, SDA pin	VIL		30%VDD	V
Input Current   Vin=VSS / VDD	All pins	IIN	-10	10	μA
Hysteresis Input Voltage1 (* 4) (VDD≥2V)	SCL pin, SDA pin	VHS1	5%VDD		V
Hysteresis Input Voltage2 (* 4) (VDD<2V)	SCL pin, SDA pin	VHS2	10%VDD		V
Low level output Voltage 1 (VDD≥ 2V)	IOL= 3mA SDA pin	VOL1		0.4	V
	IOL= 300μA INTN pin				
Low level output Voltage 2 (VDD<2V)	IOL= 3mA SDA pin	VOL2		20%VDD	V
	IOL= 300μA INTN pin				

Note:

\* 4. Reference data only, not tested in production.

**9.2.2. AC Characteristics (1): Standard Mode (100 kHz)**

(VDD=1.71 to 3.63V, Ta= -30 to 85°C, unless otherwise specified)

Parameter		Symbol	Min.	Typ.	Max.	Unit
SCL Frequency		fSCL			100	kHz
SDA bus idle time to the next command input		tBUF	4.7			μs
Start condition Hold time		tHD:STA	4.0			μs
Clock Low period		tLOW	4.7			μs
Clock High period		tHIGH	4.0			μs
Start condition set-up time		tSU:STA	4.7			μs
Data hold time		tHD:DAT	0			μs
Data set-up time		tSU:DAT	250			ns
Rise time SDA, SCL (* 5)	SDA pin, SCL pin	tR			1.0	μs
Fall time SDA, SCL (* 5)	SDA pin, SCL pin	tF			0.3	μs
Stop condition set-up time		tSU:STO	4.0			μs

Note:

\* 5. Reference data only, not tested in production.

**9.2.3. AC Characteristics (2): Fast Mode (400 kHz)**

(VDD=1.71 to 3.63V, Ta= -30 to 85°C, unless otherwise specified)

Parameter		Symbol	Min.	Typ.	Max.	Unit
SCL frequency		fSCL			400	kHz
Noise suppression time		tSP			50	ns
SDA bus idle time to the next command input		tBUF	1.3			μs
Start condition Hold time		tHD:STA	0.6			μs
Clock Low period		tLOW	1.3			μs
Clock High period		tHIGH	0.6			μs
Start condition set-up time		tSU:STA	0.6			μs
Data hold time		tHD:DAT	0			μs
Data set-up time		tSU:DAT	100			ns
Rise time SDA, SCL (* 6)	SDA pin, SCL pin	tR			0.3	μs
Fall time SDA, SCL (* 6)	SDA pin, SCL pin	tF			0.3	μs
Stop condition set-up time		tSU:STO	0.6			μs

Note:

\* 6. Reference data only, not tested in production.

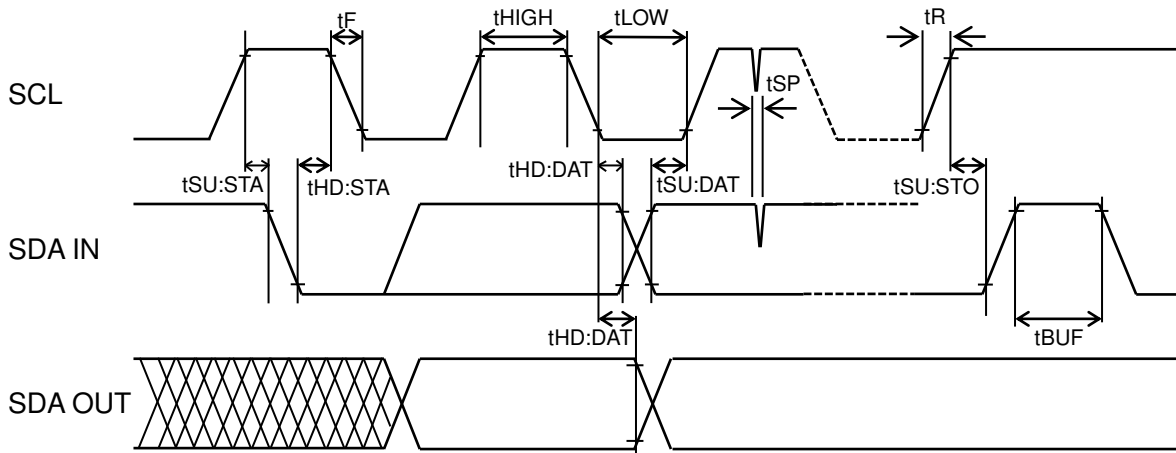

Figure 9.1. Bus Timing

**9.2.4. AC Characteristics (3): INTN**

(Unless otherwise specified, VDD=1.71 to 3.63V, Ta= -30 to 85°C)

Parameter		Symbol	Min.	Typ.	Max.	Unit
Rise time (* 7, * 8)	INTN pin	tR			2	μs
Fall time (* 7, * 8)	INTN pin	tF			0.25	μs

Note:

- \* 7. Reference data only, not tested in production.
- \* 8. When the load circuit of Figure 9.2 is connected

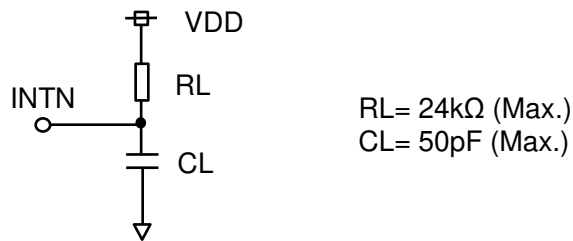

Figure 9.2. INTN Output Load Circuit



<b>10. Functional Descriptions</b>
------------------------------------

**10.1. Power Supply States**

When VDD turns on from the OFF state (0V), all registers are initialized since Power-On Reset (POR) is automatically executed, and the AK9754 is set to Stand-by Mode.

Table 10.1. Power Supply States and Functions

State	VDD pin	I <sup>2</sup> C	INTN pin	Analog Circuit	IDD
1	OFF(0V)	Disable	Unfixed	Power Down	Not specified
2	1.71V to 3.63V	Enable	"H" (* 9)	Power Down except POR circuit	Max. 3.0μA * Ta ≤ 35°C

Note:

\* 9. "H" level output by a pull-up resistor

**10.2. Reset functions**

The AK9754 is initialized in the following conditions,

## (1) Power-On Reset (POR)

When VDD turns on, AK9754 is reset by Power-On Reset (POR) until VDD reaches the operation voltage. After POR, The AK9754 is in Stand-by mode and all registers are set to their initial values. Register accesses should be made after releasing POR.

## (2) Software Reset

The AK9754 is reset by writing software reset register.

After software reset, the AK9754 generates an acknowledgement and becomes the same state as after releasing POR.

### 10.3. Operation Mode

It is assumed that the AK9754 is connected to a Host MCU.

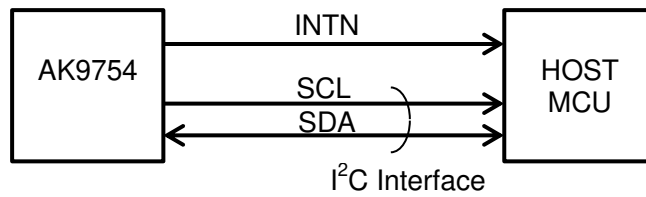

Figure 10.1. Connection Diagram

The AK9754 and a Host MCU should be connected with the I<sup>2</sup>C interface (SCL and SDA pins). The operation mode of the AK9754 can be controlled and the data can be readout from the AK9754 via the I<sup>2</sup>C interface. The slave address is determined by setting the CAD0 and CAD1 pins.

Table 10.2. Slave Address Settings

CAD1	CAD0	Slave Address
VSS	VSS	60H
VSS	non-connected	61H
VSS	VDD	62H
non-connected	VSS	64H
non-connected	non-connected	65H
non-connected	VDD	66H
VDD	VSS	68H
VDD	non-connected	69H
VDD	VDD	Do Not Use

INTN pin output can be used as interrupt control signal.  
Refer to Recommended External Circuits (Figure 17.1) for details.

There are two operation modes.

- (1) Stand-by Mode
- (2) Continuous Mode

### 10.4. Operation Modes

#### 10.4.1. Stand-by Mode (MODE = "0")

The AK9754 goes to Stand-by Mode by resetting (POR or Software RST) or setting the operating mode setting register. All circuits are powered down except for POR circuit. All registers can be accessed in this mode.

Parameters and measurement data in registers are retained, and INTN is set to the initial state("H") in this mode.

#### 10.4.2. Continuous Mode (MODE = "1")

When Continuous Mode (MODE = "1") is selected, the measurement is automatically repeated at the period of 100ms (typ.). The read-out registers will be updated every after completion of a measurement. This mode is terminated by setting Stand-by Mode (MODE = "0").

When MODE is changed during a measurement, the measurement is interrupted. Then the last data is retained in the registers.

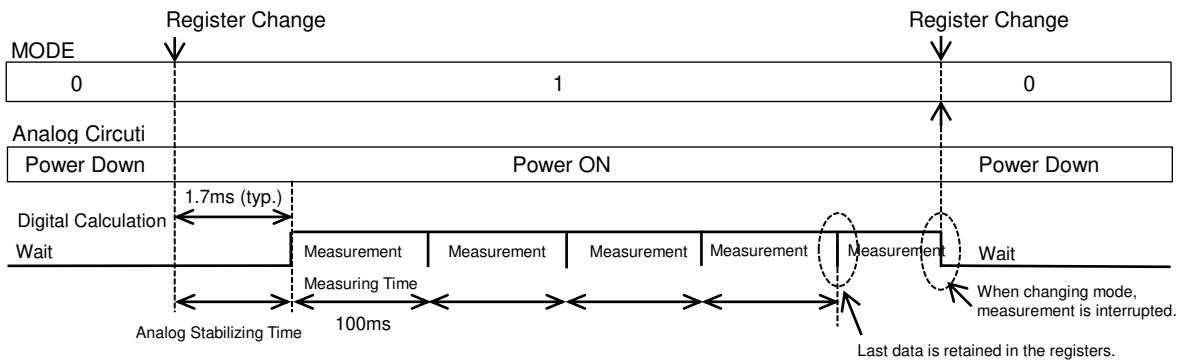

Figure 10.2. Continuous Mode

### 10.5. Synchronization Function

When using multiple AK9754s, the data sampling of each device can be synchronized by connecting the SYNC pins.

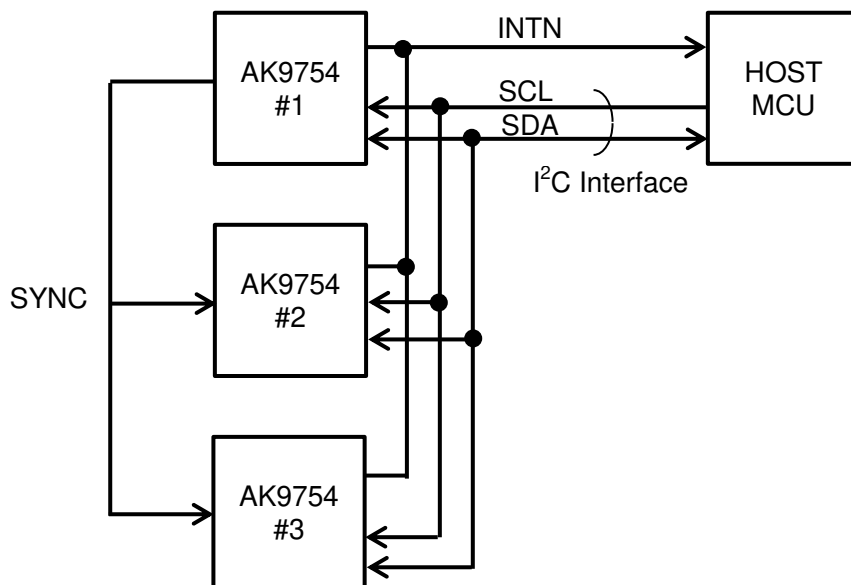

Figure 10.3. SYNC Pin Connection Example

The AK9754 should be set by the host MCU for synchronization. There are a master and slave devices for synchronization communication. Figure 10.3 shows an example of when the AK9754(#1) is a master device, and the AK9754(#2) and the AK9754(#3) are slave devices. Master/Slave mode setting of each device is set by the synchronization setting register (SYNCRM[1:0], Address 21H).

### 10.6. Sampling Data Storage Function

The AK9754 has a streaming buffer that can store maximum 10 samplings of IR sensor data. Only the data from IR sensor is stored to the streaming buffer and the data from temperature sensor will not be stored.

The AK9754 starts storing the data by writing "1" to SBEN bit (Address: 2AH). In this time, the data previously stored to the streaming buffer will be deleted. When the data storing is executed for more than 10 samplings, the oldest data is deleted and the newest data is stored. Therefore, the streaming buffer always stores 10 newest sampling data.

Data update of the streaming buffer will be stopped by writing "0" to SBEN bit or when the internal algorithm detects a human approach (Stop/Continue setting of the data update on Human Approach Detection can be set by SBHBD). When data update is stopped, data stored in the streaming buffer is kept. Therefore, maximum 10 sampling data before Human Approach Detection can be readout. When using multiple AK9754s at the same time, start storing of the streaming buffer data and stop timing of the data update can be set independently for each device. AK9754s stop data update simultaneously when detecting a human approach. Refer to "10.7 Measurement Data Read" for storing data of the streaming buffer and readout sequence of the data.

## 10.7. Measurement Data Read

Measurement data of the AK9754 can be read out by reading Measurement Data Registers or Streaming Buffers.

- Measurement Data Register Read

Measurement data that is updated in every Measurement Cycle of the AK9754 is read out. There are two kinds of measurement data: IR sensor and internal temperature sensor. The latest data of these can be read out by this function.

- Streaming Buffer Read

Streaming Buffer that is able to store the measurement data for 10 samples at maximum can be read out. Only the IR sensor measurement data is read out by this operation. Write "1" to SBEN bit (address: 2AH) to start storing measurement data to the Streaming Buffer when using this function.

Use "Measurement Data Register" Read when reading the latest Measurement Data.

Use "Streaming Buffer Read" when reading the latest data (10 samples at maximum) from detecting Human approach.

### 1. Read Measurement Data Registers

The latest Measurement Data is read out.

DRDY bit of ST1 register changes to "1" when Measurement Data read becomes available after the data is stored and updated. This is called "Data Ready" status.

HBDR1 bit of ST1 register changes to "1" when the internal algorithm of the AK9754 detects a human approach. The INTN pin can be set to output "L" by interrupt register settings, HBDIEN and DRIEN bits (Address: 2AH), when these changes are occurred.

Table 10.3. Measurement Data Register Read

Register	Address	Data
ST1	04H	DRDY, HBDR1
IRL	05H	IR[7:0]
IRH	06H	IR[15:8]
TMPL	07H	TMP[7:0]
TMPH	08H	TMP[15:8]
ST2	09H	DOR, HBDR2

(1) Read ST1 Register

DRDY: Indicate data ready status. When this bit is "1", the AK9754 is in data ready status.

HBDR1: Indicate whether the algorithm detected a human approach.  
This bit changes to "1" and the value is kept when the AK9754 detects a human approach.

By reading these bits, interruption factor of the INTN pin output "L" can be determined.

(2) Read Measurement Data Registers

Read out IR sensor or internal temperature sensor data.

When read out these registers, measurement data is transferred to read registers and saved. The INTN pin output returns to "H" after reading out the IR sensor data.

(3) Read ST2 Register

DOR: Indicate if there is data that was not read before the data that is read out.  
 When this bit is "0", there is no data that was not read out from the previous data read.  
 When this bit is "1", there is data that was not read out.

HBDR2: Indicate whether the algorithm detected a human approach in the latest measurement data. This bit changes to "1" when the AK9754 detects a human approach.

The AK9754 recognizes that a data read out has finished by read out the ST2 registers. Measurement data is not updated during data read since it is protected. This data protection is released by reading ST2 register. It must be read out after reading the Measurement Data Registers.

By reading this register, DRDY and HBDR1 bits return to "0" automatically.

Procedure for reading "Measurement Data Register"

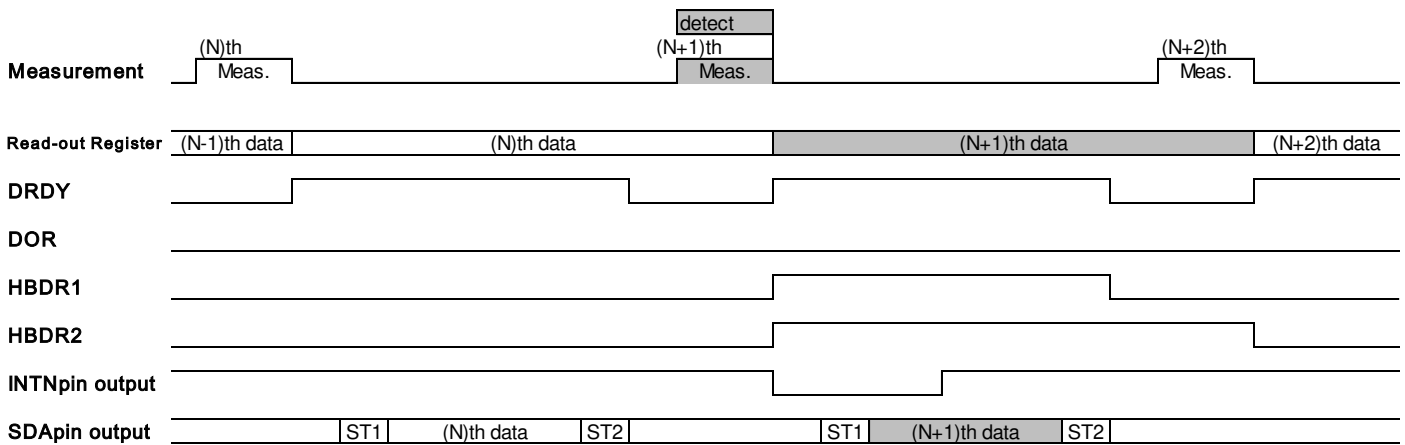

Figure 10.2. Interruption by Human Detection (HBDIEN="1",DRIEN="0")

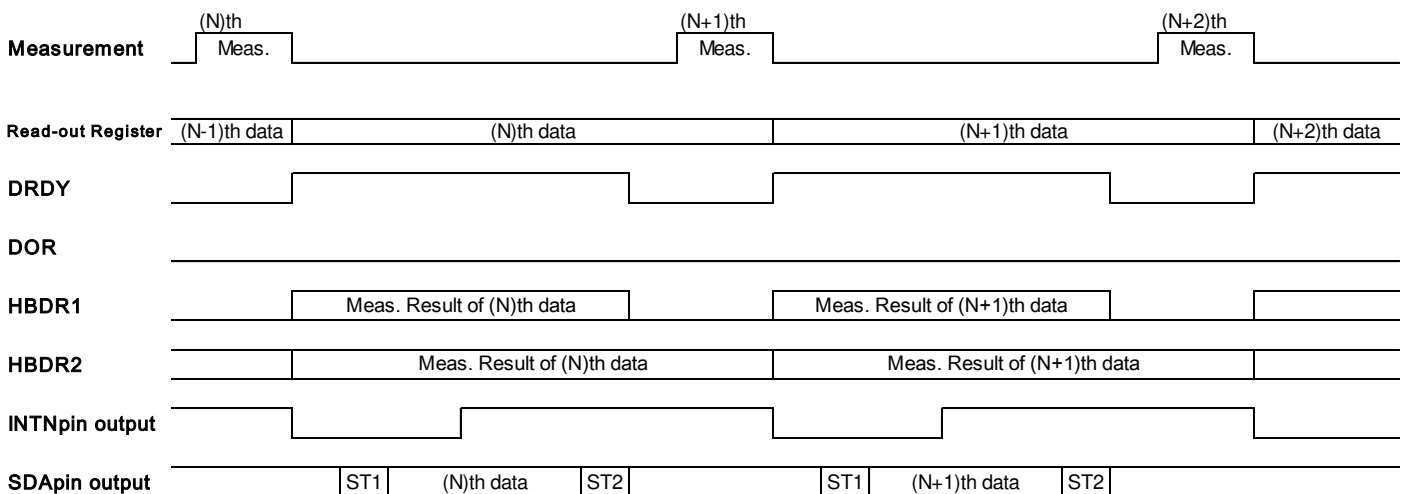

Figure 10.3. Interruption by Data Ready (HBDIEN="0",DRIEN="1")

## 2. Read Streaming Buffer

To store measurement data in the Streaming Buffer, set SBEN = "1" (Address 2AH D [2]).

By setting SBHBD = "1" (Address 2AH D [3]), data update in the Streaming Buffer can be stopped when the internal algorithm detects human approach.

By reading the Streaming Buffer at the above setting, it is possible to read the latest data (10 samples at maximum) from detecting Human approach.

SBEN bit returns to "0" automatically when data updating of the Streaming Buffer is stopped.

SBNMB[3:0] bits shows the number of measurement data stored in the Streaming Buffer.  
HBDR3 bit (ST3 Register) changes to "1" when detecting a human approach.

Table 10.4. Streaming Buffer Read

Register	Address	Data
ST3	0AH	HBDR3, SBNMB[3:0]
SB0L	0BH	SB0[7:0] (latest)
SB0H	0CH	SB0[15:8] (latest)
...	...	...
SB9L	1DH	SB9[7:0] (9 samples before)
SB9H	1EH	SB9[15:8] (9 samples before)
ST4	1FH	HBDR4

### (1) Read ST3 Register

SBNMB[3:0]: Indicate the number of data that stored in the Streaming Buffer. (Max. 10)  
The number of valid data can be confirmed by reading these bits.

HBDR3: Indicate whether the algorithm detected a human approach.  
This bit changes to "1" and the value is kept when the AK9754 detects a human approach.

### (2) Read Streaming Buffer

Read out Streaming Buffer data.

Once starting to read this register, measurement data obtained during register read will not be stored to the Streaming Buffer.

### (3) Read ST4 Register

HBDR4: Indicate whether the algorithm detected a human approach in the latest measurement data. This bit changes to "1" when the AK9754 detects a human approach.

The AK9754 recognizes that a data read out has finished by read out the ST4 registers.

Measurement data is not updated during data read since it is protected. This data protection is released by reading ST4 register.

SBNMB[3:0] and HBDR3 bits and measurement data stored in the Streaming Buffer is reset by setting SBEN bit = "1".

In order to return the INTN pin output to "H", read the measurement data of the IR sensor(Address 05H).  
After reading the IR register, read the ST2 register(Address 09H).

Procedure for reading "Streaming Buffer"

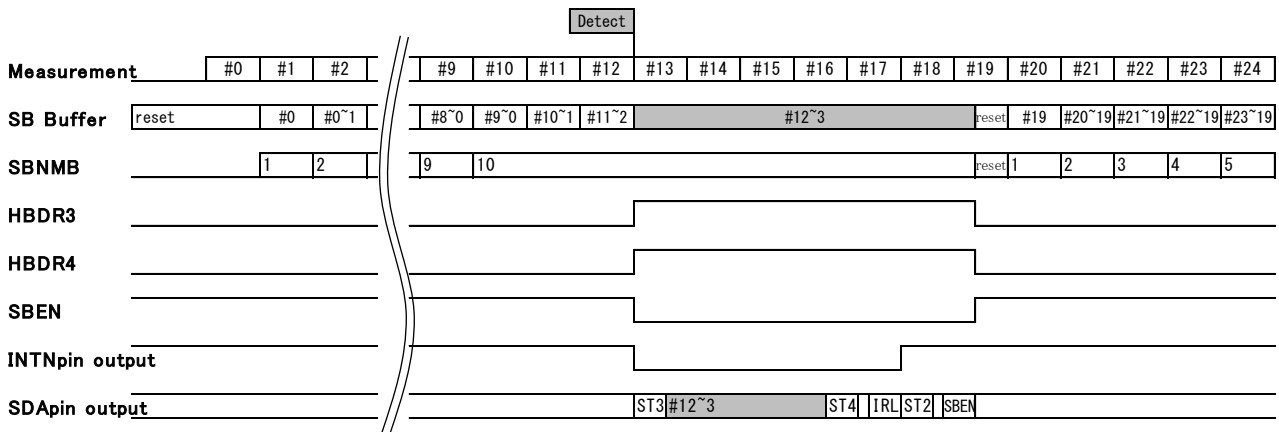

Figure 10.4. "Stop SB update at Human Detection" (HBDIEN="1",SBHBD="1")

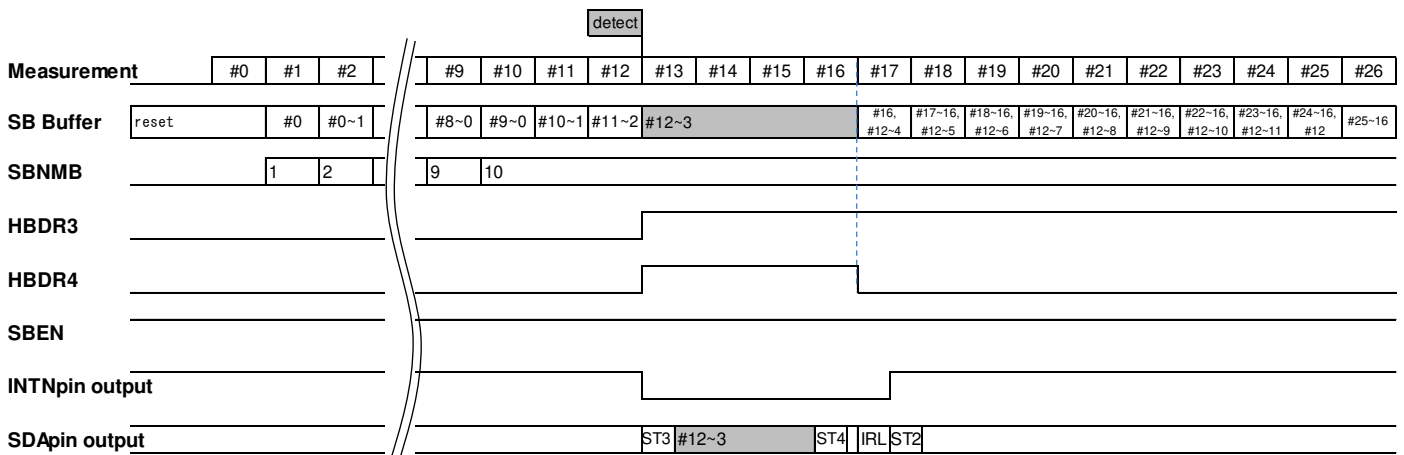



Figure 10.5. "Update SB at Human Detection" (HBDIEN="1",SBHBD="0")



**10.8. Data Read Sequence Example**

Data read sequence of the AK9754 is shown below.

Table 10.5. Data read sequence setting

Address	Name	DATA	
21H	CNTL2	FCH	SYNCM[1:0]: Synchronization Mode Setting "00": No Synchronization (default)
22H	CNTL3	A9H	LNM: Low Noise Mode "0": Low-noise Mode Disable (default)  ODR[1:0]: Data Output Rate(Frequency) Setting "10" : ODR 10Hz(default)  FCTMP[1:0]: Low Pass Filter Cutoff Frequency (Fc) Setting for internal temperature sensor "10" : Fc =0.445Hz(default)  FCIR[1:0]: IR Sensor Low Pass Filter Cutoff Frequency (Fc) "01" : Fc =0.9Hz(default)
23H	CNTL4	F8H	TOPT[2]: Automatic threshold adjustment according to signal temperature characteristics. "0": Disable  TOPT[1:0]: Optimize noise and current consumption with Built-in Temperature Sensor. "00": Disable
24H	CNTL5	80H	TMPOFS[6:0]: Temperature Sensor Offset Setting 0000000:0 °C
25H	CNTL6	FAH	IRGAIN[4:0] 11010
26H	CNTL7	F0H	IRINV: Human Approach Detection algorithm input signal Invert Setting "0": Normal (default)  IDLET[2:0]: Human Approach Detection algorithm Idling Time Setting "000" : 0sec (default)
27H	CNTL8	81H	DTCT[6:0]: Detection Time Setting "000001" : 1  (default)
28H	CNTL9	2CH	Threshold of Human Approach Detection Algorithm (Lower) Default : HBDTH[7:0] = "00101100"
29H	CNTL10	81H	Threshold of Human Approach Detection Algorithm (Upper) Default : HBDTH[14:8] = "0000001"
2AH	CNTL11	F2H	HB DEN : Human Approach Detection Enable "1": Human Approach Detection Algorithm ON  SBHBD: Update of Streaming Buffer (SB) by Human Approach Detection "0": Do Not Stop Updating SB (default)  SBEN: Streaming Buffer (SB) Enable "0": SB OFF (default)  HBDIEN : Interrupt Enable on Human Sensing "1": Interrupt Setting Enable  DRIEN : Interrupt Enable on Data Ready "0": Interrupt Setting Disable (default)

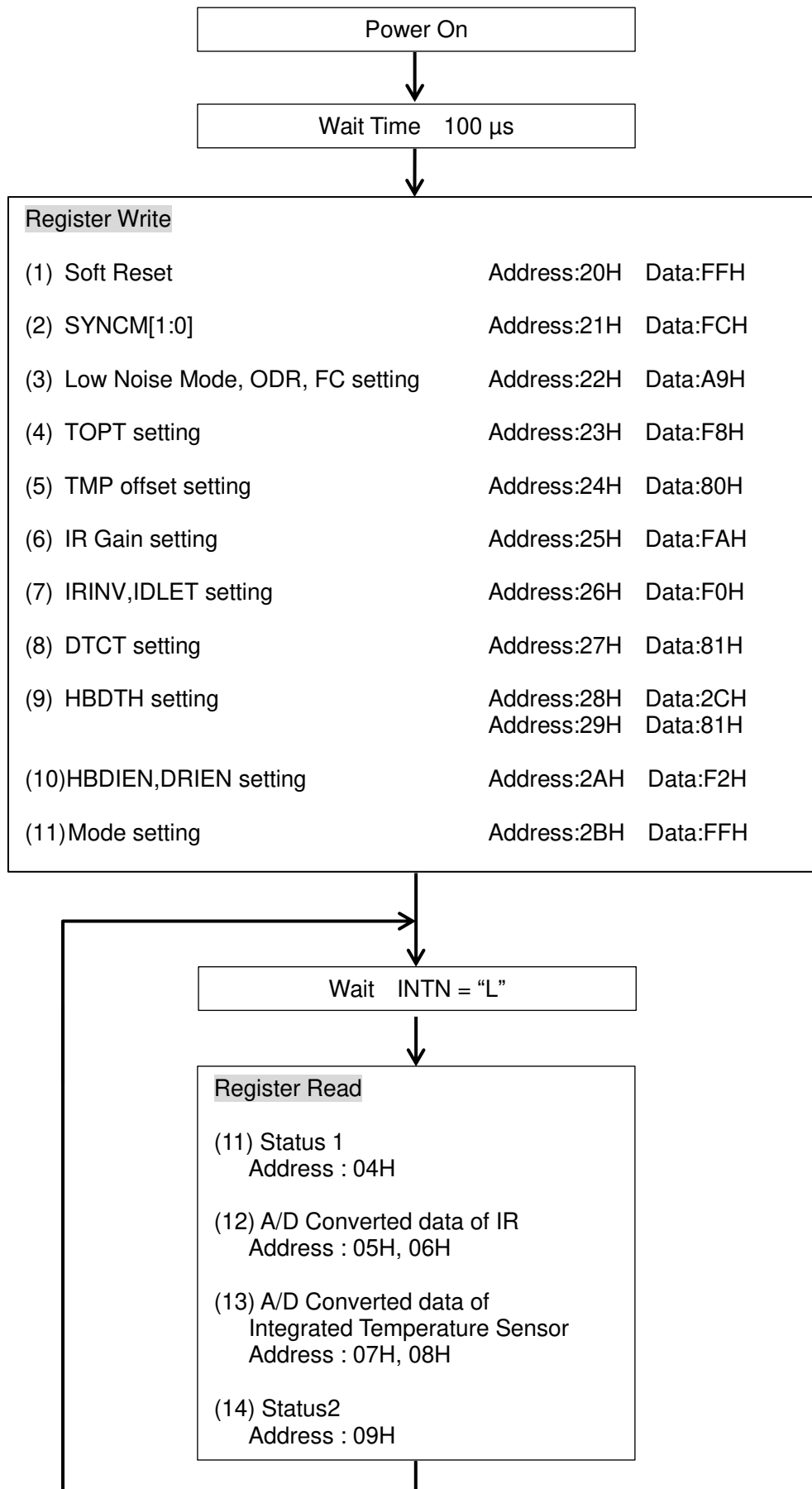

**10.9. Internal Algorithm**

The AK9754 integrates a Human Approach Detection algorithm. The outline of this algorithm is shown as below. When HBDEN bit set to "1" ,changing the bit of MODE to "1" starts this algorithm. After this algorithm start to working, the AK9754 is idled to being set time. When the IDLE time is over, the Threshold Judgment is carried out for the IR measurement data. If it exceeds the threshold continuously for more than a certain number of times, it is judged that a human approached. HBDR\* bit (ST\* Register) is changes to "1" when detecting a human approach. At this time, if the HBDIEN bit is "1", the INTN pin is asserted.

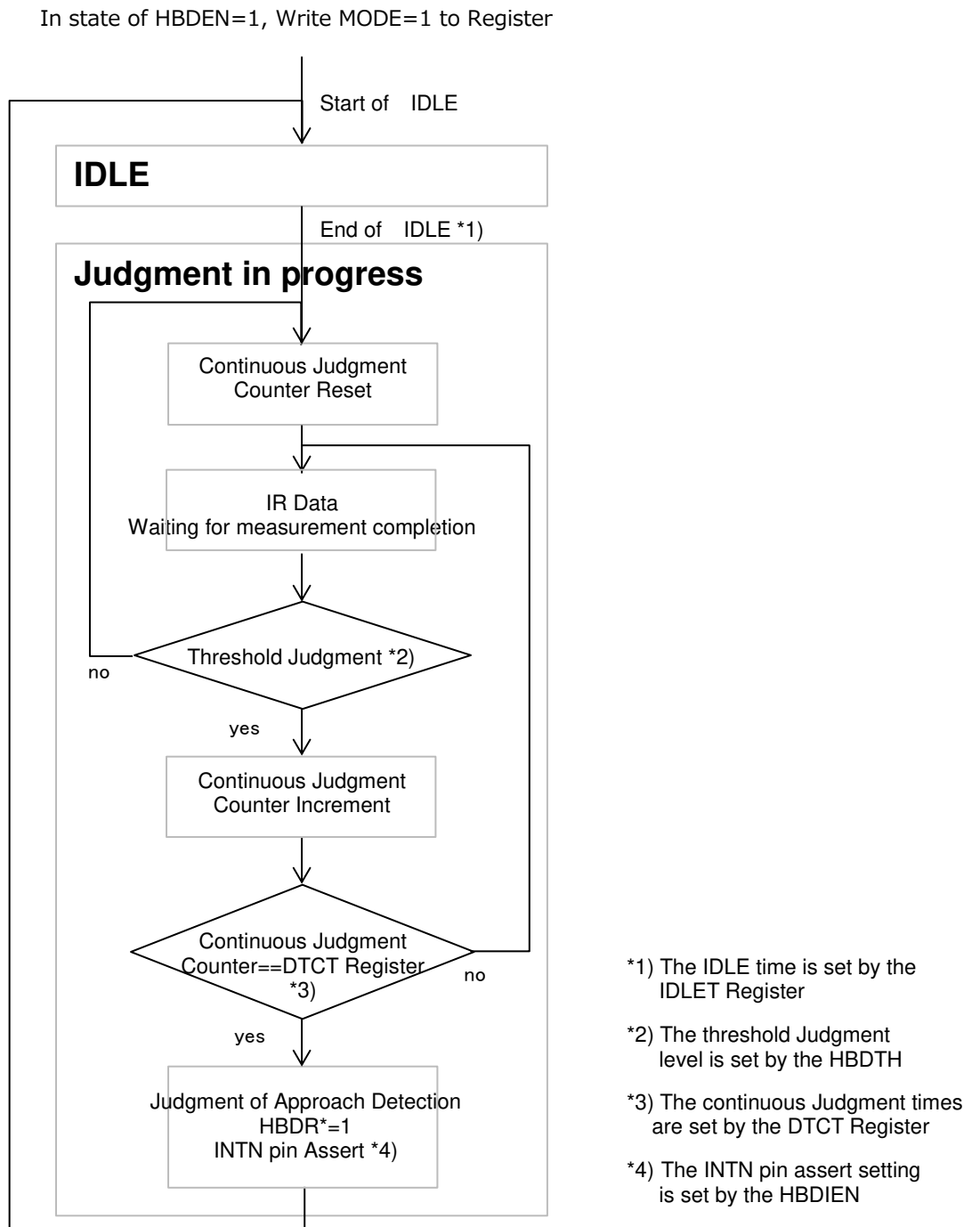

Figure 10.6 Outline of Human Approach Detection Algorithm

## 11. Serial Interface

The I<sup>2</sup>C bus interface of the AK9754 supports Standard Mode (Max. 100kHz) and Fast Mode (Max. 400kHz)

### 11.1. Data Transfer

Access AK9754 through the I<sup>2</sup>C bus after POR.

Initially the Start Condition should be input to access the AK9754 through the bus. Next, send a one byte slave address, which includes the device address. The AK9754 compares the slave address, and if these addresses match, the AK9754 generates an acknowledge signal and executes a read / write command. The Stop Condition should be input after executing a command.

#### 11.1.1. Changing state of the SDA line

The SDA line state should be changed only while the SCL line is "L". The SDA line state must be maintained while the SCL line is "H". The SDA line state can be changed while the SCL line is "H", only when a Start Condition or a Stop Condition is input.

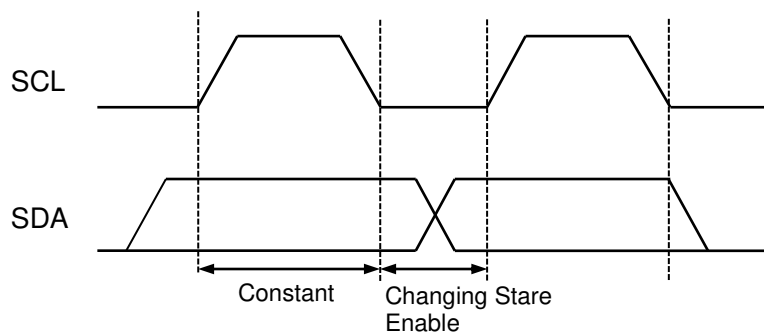

Figure 11.1.Changing state of SDA line

#### 11.1.2. Start / Stop Conditions

A Start Condition is generated when the SDA line state is changed from "H" to "L" while the SCL line is "H". All command start from a Start Condition.

A Stop condition is generated when the SDA line state is changed from "L" to "H" while the SCL line is "H". All command end after a Stop Condition.

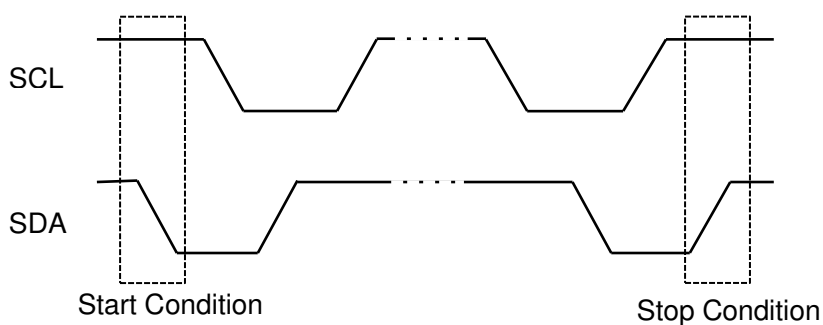

Figure 11.2. Start / Stop Conditions

### 11.1.3. Acknowledge

The device transmitting data will release the SDA line after transmitting one byte of data (SDA line state is "H"). The device receiving data will pull the SDA line to "L" during the next clock. This operation is called "Acknowledge". The Acknowledge signal can be used to indicate successful data transfers.

The AK9754 will output an acknowledge signal after receiving a Start Condition and the slave address.

The AK9754 will output an acknowledge signal after receiving each byte, when the write instruction is transmitted.

The AK9754 will transmit the data stored in the selected address after outputting an acknowledge signal, when a read instruction is transmitted. Then the AK9754 will monitor the SDA line after releasing the SDA line. If the master device generates an Acknowledge instead of Stop Condition, the AK9754 transmits an 8-bit data stored in the next address. When the Acknowledge is not generated, transmitting data is terminated.

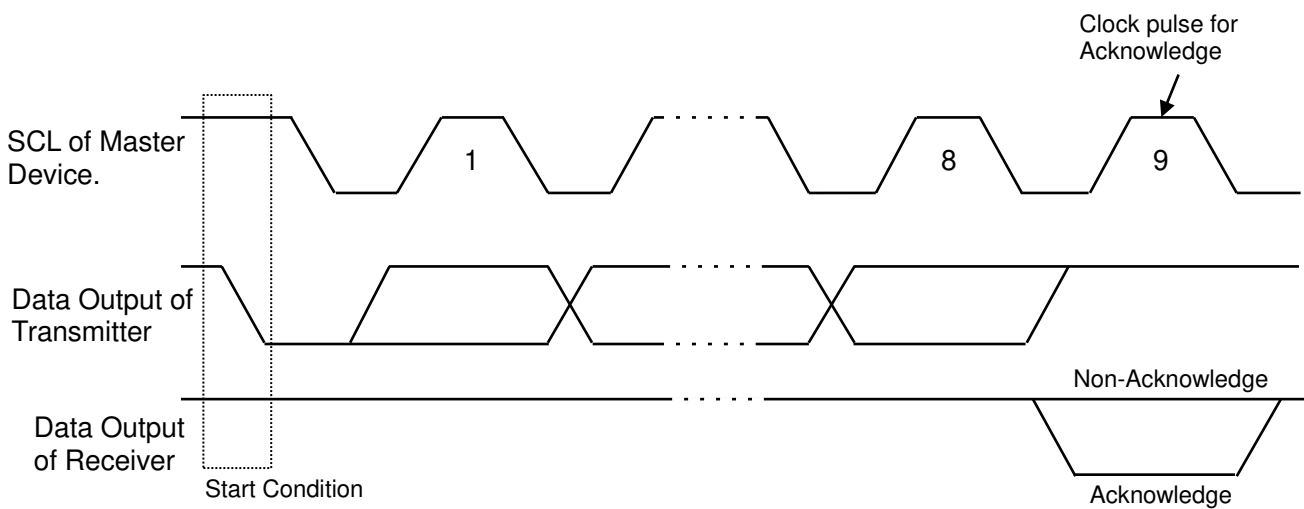

Figure 11.3. Acknowledge

#### 11.1.4. Slave Address

A slave address of the AK9754 is determined by connecting the CAD0 pin and the CAD1 pin to VDD or VSS, or leaving them to open.

Table 11.1. Setting of CAD0 and CAD1 Pins, and Slave Address

CAD1	CAD0	Slave Address
VSS	VSS	60H
VSS	non-connected	61H
VSS	VDD	62H
non-connected	VSS	64H
non-connected	non-connected	65H
non-connected	VDD	66H
VDD	VSS	68H
VDD	non-connected	69H
VDD	VDD	Do Not Use

When the first one byte data including the slave address is transmitted after a Start Condition, the device, which is specified as the communicator by the slave address on bus, is selected.

After transmitting the slave address, the device that has the corresponding device address will execute a command after transmitting an Acknowledge signal. The 8-bit (Least Significant bit-LSB) of the first one byte is the R/W bit.

When the R/W bit is set to "1", a read command is executed. When the R/W bit is set to "0", a write command is executed.

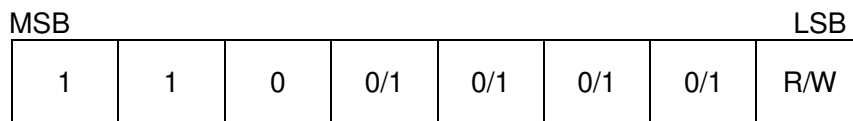

Figure 11.4. Slave Address

#### 11.1.5. Write Command

When the R/W bit set to "0", the AK9754 executes a write operation. The AK9754 will output an Acknowledge signal and receive the second byte, after receiving a Start Condition and first one byte (slave address) in a write operation. The second byte has an MSB-first configuration, and specifies the address of the internal control register.

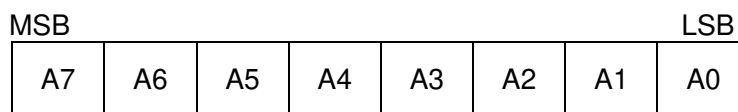

Figure 11.5. Register Address

The AK9754 will generate an Acknowledge and receive the third byte after receiving the second byte (Register Address).

The data after the third byte are the control data. The control data consists of 8-bit and has an MSB-first configuration. The AK9754 generates an Acknowledge for each byte received. The data transfer is terminated by a Stop Condition, generated by the master device.

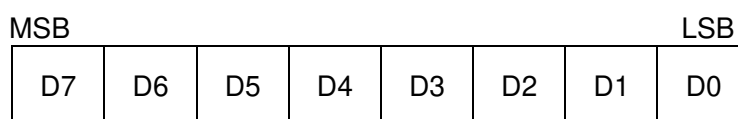

Figure 11.6. Control data

Two or more bytes can be written at once. The AK9754 generates an Acknowledge and receives the next data after receiving the third byte (Control Data). When the following data is transmitted without a Stop Condition, after transmitting one byte, the internal address counter is automatically incremented, and data is written in the next address.

This automatic address increment works for the registers of CNTL1 to CNTL12 (20H to 2BH). The address counter returns to address 20H after reaching address 2BH.

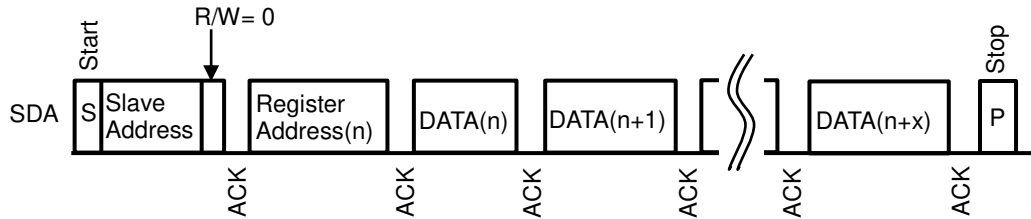

Figure 11.7. Write Operation

### 11.1.6. Read Command

When the R/W bit is set to "1", the AK9754 executes a read operation. When the AK9754 transmits data from the specified address, the master device generates an Acknowledge instead of a Stop Condition and the next address data can be read out.

This automatic address increment works for the registers which store ST1, IR measurement data, Temperature Sensor data, ST2 data (04H to 09H), ST3, SB and ST4 data (0AH to 1FH) and setting registers of CNTL1 to CNTL12 (20H to 2BH).

The address counter returns to address 04H after reaching address 09H, returns to 0AH after 1FH and returns to 20H after 2BH.

The AK9754 supports both current address read and random address read

#### (1) Current Address Read

The AK9754 has an integrated address counter. The data specified by the counter is read out in the current address read operation. The internal address counter retains the next address which is accessed at last. For example, when the address which was accessed last is "n", the data of address "n+1" is read out by the current address read instruction.

The AK9754 will generate an Acknowledge after receiving the slave address for a read command (R/W bit = "1") in the current address read operation. Then the AK9754 will start to transmit the data specified by the internal address counter at the next clock, and will increment the internal address counter by one. When the AK9754 generates a Stop Condition instead of an Acknowledge after transmitting the one byte data, a read out operation is terminated.

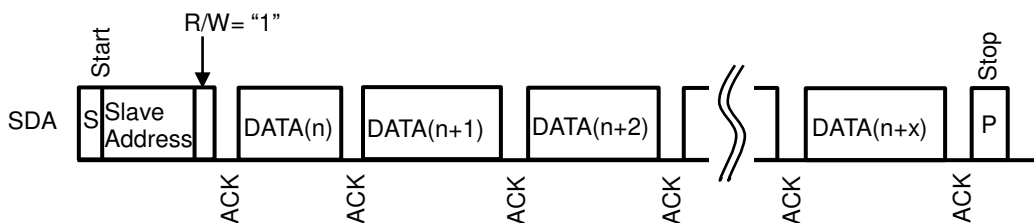

Figure 11.8. Current Address Read

**(2) Random Read**

Data from an arbitrary address can be read out by a random read operation. A random read requires the input of a dummy write instruction before the input of the slave address of a read instruction (R/W bit = "1"). To execute a random read, first generate a Start Condition, then input the slave address for a write instruction (R/W bit = "0") and a read address, sequentially.

After the AK9754 generates an Acknowledge in response to this address input, generate a Start Condition and the slave address for a read instruction (R/W bit = "1") again. The AK9754 generates an Acknowledge in response to the input of this slave address. Next, the AK9754 outputs the data at the specified address, then increments the internal address counter by one.

When a Stop Condition from the master device is generated instead of an Acknowledge after the AK9754 outputs data, Read operation stops.

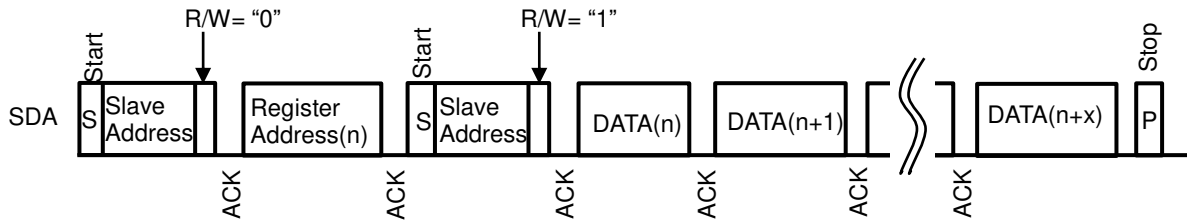

Figure 11.9. Random Read



## 12. Memory Map

Table 12.1. Register Map

Name	Address	Soft Reset	R/W	Address Increment	Data
					Contents
WIA1	00H	Disable	R		Company code
WIA2	01H	Disable	R		Device ID
INFO1	02H	Disable	R		Information
INFO2	03H	Disable	R		Information
ST1	04H	Enable	R	←	HBDR1: Detection result, DRDY: Data ready flag
IRL	05H	Enable	R		IR measurement data low bit
IRH	06H	Enable	R		IR measurement data high bit
TMPL	07H	Enable	R		Integrated temperature sensor measurement data low bit
TMPH	08H	Enable	R		Integrated temperature sensor measurement data high bit
ST2	09H	Enable	R	↓	HBDR2: Detection result, DOR: Data overrun flag
ST3	0AH	Enable	R	←	HBDR3: Detection result, SBNMB[3:0]: Number of Valid Data in SB
SB0L	0BH	Enable	R		SBNL: (N+1)-th latest IR measurement data low bit SBNH: (N+1)-th latest IR measurement data high bit
SB0H	0CH	Enable	R		
SB1L	0DH	Enable	R		
SB1H	0EH	Enable	R		
SB2L	0FH	Enable	R		
SB2H	10H	Enable	R		
SB3L	11H	Enable	R		
SB3H	12H	Enable	R		
SB4L	13H	Enable	R		
SB4H	14H	Enable	R		
SB5L	15H	Enable	R		
SB5H	16H	Enable	R		
SB6L	17H	Enable	R		
SB6H	18H	Enable	R		
SB7L	19H	Enable	R		
SB7H	1AH	Enable	R		
SB8L	1BH	Enable	R		
SB8H	1CH	Enable	R		
SB9L	1DH	Enable	R		
SB9H	1EH	Enable	R		
ST4	1FH	Enable	R	↓	HBDR4: Detection result,
CNTL1	20H	Enable	RW	←	SRST: Soft reset
CNTL2	21H	Enable	RW		SYNCM[1:0]: Synchronized operation mode setting
CNTL3	22H	Enable	RW		LNМ: Low noise mode setting, ODR[1:0]: Output data rate setting, FCTMP[1:0]: TMP data lowpass filter setting, FCIR[1:0]: IR data lowpass filter setting
CNTL4	23H	Enable	RW		TOPT: Mode setting of optimized operation by integrated temperature sensor
CNTL5	24H	Enable	RW		TMPOFS: Offset value of integrated temperature sensor
CNTL6	25H	Enable	RW		IRGAIN[4:0]: IR signal gain setting.
CNTL7	26H	Enable	RW		IRINV: Inversion setting of IR, IDLET[2:0]: Idling time setting
CNTL8	27H	Enable	RW		DTCT[6:0]: Detection time setting
CNTL9	28H	Enable	RW		HBDTH[7:0]: Human detection threshold setting low bit
CNTL10	29H	Enable	RW		HBDTH[15:8]: Human detection threshold setting high bit
CNTL11	2AH	Enable	RW		HBDEN: Enabling of Human Approach Detection, SBHBD: Enabling of streaming buffer, HBDIEN: Enabling of interrupt caused by Human Approach Detection result, DRIEN: Enabling of interrupt caused by data ready
CNTL12	2BH	Enable	RW	↓	MODE: Measurement start setting

<b>13. Register Definitions</b>
---------------------------------

Table 13.1. Register Map

Address	Name	D7	D6	D5	D4	D3	D2	D1	D0
00H	WIA1	0	1	0	0	1	0	0	0
01H	WIA2	0	0	0	1	0	1	0	1
02H	INFO1	0	0	0	0	0	0	0	0
03H	INFO2	0	0	0	0	0	0	0	0
04H	ST1	1	1	1	HBDR1	1	1	1	DRDY
05H	IRL	IR[7]	IR[6]	IR[5]	IR[4]	IR[3]	IR[2]	IR[1]	IR[0]
06H	IRH	IR[15]	IR[14]	IR[13]	IR[12]	IR[11]	IR[10]	IR[9]	IR[8]
07H	TMPL	TMP[7]	TMP[6]	TMP[5]	TMP[4]	TMP[3]	TMP[2]	TMP[1]	TMP[0]
08H	TMPH	TMP[15]	TMP[14]	TMP[13]	TMP[12]	TMP[11]	TMP[10]	TMP[9]	TMP[8]
09H	ST2	1	1	1	HBDR2	1	1	1	DOR
0AH	ST3	1	1	1	HBDR3	SBNMB[3]	SBNMB [2]	SBNMB[1]	SBNMB [0]
0BH	SB0L	SB0[7]	SB0[6]	SB0[5]	SB0[4]	SB0[3]	SB0[2]	SB0[1]	SB0[0]
0CH	SB0H	SB0[15]	SB0[14]	SB0[13]	SB0[12]	SB0[11]	SB0[10]	SB0[9]	SB0[8]
0DH	SB1L	SB1[7]	SB1[6]	SB1[5]	SB1[4]	SB1[3]	SB1[2]	SB1[1]	SB1[0]
0EH	SB1H	SB1[15]	SB1[14]	SB1[13]	SB1[12]	SB1[11]	SB1[10]	SB1[9]	SB1[8]
0FH	SB2L	SB2[7]	SB2[6]	SB2[5]	SB2[4]	SB2[3]	SB2[2]	SB2[1]	SB2[0]
10H	SB2H	SB2[15]	SB2[14]	SB2[13]	SB2[12]	SB2[11]	SB2[10]	SB2[9]	SB2[8]
11H	SB3L	SB3[7]	SB3[6]	SB3[5]	SB3[4]	SB3[3]	SB3[2]	SB3[1]	SB3[0]
12H	SB3H	SB3[15]	SB3[14]	SB3[13]	SB3[12]	SB3[11]	SB3[10]	SB3[9]	SB3[8]
13H	SB4L	SB4[7]	SB4[6]	SB4[5]	SB4[4]	SB4[3]	SB4[2]	SB4[1]	SB4[0]
14H	SB4H	SB4[15]	SB4[14]	SB4[13]	SB4[12]	SB4[11]	SB4[10]	SB4[9]	SB4[8]
15H	SB5L	SB5[7]	SB5[6]	SB5[5]	SB5[4]	SB5[3]	SB5[2]	SB5[1]	SB5[0]
16H	SB5H	SB5[15]	SB5[14]	SB5[13]	SB5[12]	SB5[11]	SB5[10]	SB5[9]	SB5[8]
17H	SB6L	SB6[7]	SB6[6]	SB6[5]	SB6[4]	SB6[3]	SB6[2]	SB6[1]	SB6[0]
18H	SB6H	SB6[15]	SB6[14]	SB6[13]	SB6[12]	SB6[11]	SB6[10]	SB6[9]	SB6[8]
19H	SB7L	SB7[7]	SB7[6]	SB7[5]	SB7[4]	SB7[3]	SB7[2]	SB7[1]	SB7[0]
1AH	SB7H	SB7[15]	SB7[14]	SB7[13]	SB7[12]	SB7[11]	SB7[10]	SB7[9]	SB7[8]
1BH	SB8L	SB8[7]	SB8[6]	SB8[5]	SB8[4]	SB8[3]	SB8[2]	SB8[1]	SB8[0]
1CH	SB8H	SB8[15]	SB8[14]	SB8[13]	SB8[12]	SB8[11]	SB8[10]	SB8[9]	SB8[8]
1DH	SB9L	SB9[7]	SB9[6]	SB9[5]	SB9[4]	SB9[3]	SB9[2]	SB9[1]	SB9[0]
1EH	SB9H	SB9[15]	SB9[14]	SB9[13]	SB9[12]	SB9[11]	SB9[10]	SB9[9]	SB9[8]
1FH	ST4	1	1	1	HBDR4	1	1	1	1
20H	CNTL1	1	1	1	1	1	1	1	SRST
21H	CNTL2	1	1	1	1	1	1	SYNCM[1]	SYNCM[0]
22H	CNTL3	1	LNM	ODR[1]	ODR[0]	FCTMP[1]	FCTMP[0]	FCIR[1]	FCIR[0]
23H	CNTL4	1	1	1	1	1	TOPT[2]	TOPT[1]	TOPT[0]
24H	CNTL5	1	TMPOFS[6]	TMPOFS[5]	TMPOFS[4]	TMPOFS[3]	TMPOFS[2]	TMPOFS[1]	TMPOFS[0]
25H	CNTL6	1	1	1	IRGAIN[4]	IRGAIN[3]	IRGAIN[2]	IRGAIN[1]	IRGAIN[0]
26H	CNTL7	1	1	1	1	IRINV	IDLET[2]	IDLET[1]	IDLET[0]
27H	CNTL8	1	DTCT[6]	DTCT[5]	DTCT[4]	DTCT[3]	DTCT[2]	DTCT[1]	DTCT[0]
28H	CNTL9	HBDTH[7]	HBDTH[6]	HBDTH[5]	HBDTH[4]	HBDTH[3]	HBDTH[2]	HBDTH[1]	HBDTH[0]
29H	CNTL10	1	HBDTH[14]	HBDTH[13]	HBDTH[12]	HBDTH[11]	HBDTH[10]	HBDTH[9]	HBDTH[8]
2AH	CNTL11	1	1	1	HB DEN	SBHBD	SBEN	HBDIEN	DRIEN
2BH	CNTL12	1	1	1	1	1	1	1	MODE

Note: "1" written in 20H to 2BH is reserved bit. Read "1" regardless of the write value.

## [Functional Descriptions]

## 1). WIA1: Company Code (Read Only Register)

Address	Name	D7	D6	D5	D4	D3	D2	D1	D0
00H	WIA1	0	1	0	0	1	0	0	0

One Byte fixed code as Company code of AKM. (48H)

## 2). WIA2: Device ID (Read Only Register)

Address	Name	D7	D6	D5	D4	D3	D2	D1	D0
01H	WIA2	0	0	0	1	0	1	0	1

One Byte fixed code as AKM device ID. (15H)

## 3). INFO1: Information1 (Read Only Register)

Address	Name	D7	D6	D5	D4	D3	D2	D1	D0
02H	INFO1	0	0	0	0	0	0	0	0

INFO1 [7:0]: Information for AKM use only.

## 4). INFO2: Information2 (Read Only Register)

Address	Name	D7	D6	D5	D4	D3	D2	D1	D0
03H	INFO2	0	0	0	0	0	0	0	0

INFO2 [7:0]: Reserve

## 5). ST1: Status1 (Read Only Register)

Address	Name	D7	D6	D5	D4	D3	D2	D1	D0
04H	ST1	1	1	1	HBDR1	1	1	1	DRDY
	Reset	1	1	1	0	1	1	1	0

HBDR1: Human Approach Detection result 1

“0”: Initial Value (default)

“1”: Human Approach Detect

HBDR1 bit becomes “1” when detecting a human approach. It returns to “0” when readout of the measurement data buffer is completed.

DRDY: Data Ready

“0”: Normal State (default)

“1”: Data Ready

DRDY bit changes to “1” when measurement data is ready to be read. This bit returns to “0” when ST2 register is read out.

## 6). IR: Measurement data of IR Sensor (Read Only Register)

Address	Name	D7	D6	D5	D4	D3	D2	D1	D0
05H	IRL	IR[7]	IR[6]	IR[5]	IR[4]	IR[3]	IR[2]	IR[1]	IR[0]
06H	IRH	IR[15]	IR[14]	IR[13]	IR[12]	IR[11]	IR[10]	IR[9]	IR[8]
Reset		0	0	0	0	0	0	0	0

Measurement data of IR Sensor

IR[7:0]: Lower 8-bit of output data

IR[15:8]: Upper 8-bit of output data

16-bit data is stored in 2's compliment format.

Table 13.2. Measurement data of IR Sensor(2's compliment)

Measurement data of IR Sensor [15:0]			Output current of IR Sensor	Unit
Bin	Hex	Dec		
0111 1111 1111 1111	7FFF	32767	15000 or more	pA
⋮	⋮	⋮	⋮	
0010 0111 0001 0000	2710	10000	4578	
⋮	⋮	⋮	⋮	
0000 0011 1110 1000	03E8	1000	457.8	
⋮	⋮	⋮	⋮	
0000 0000 0110 0100	0064	100	45.78	
⋮	⋮	⋮	⋮	
0000 0000 0000 0001	0001	1	0.4578	
0000 0000 0000 0000	0000	0	0	
1111 1111 1111 1111	FFFF	-1	-0.4578	
⋮	⋮	⋮	⋮	
1111 1111 1001 1100	FF9C	-100	-45.78	
⋮	⋮	⋮	⋮	
1111 1100 0001 1000	FC18	-1000	-457.8	
⋮	⋮	⋮	⋮	
1101 1000 1111 0000	D8F0	-10000	-4578	
⋮	⋮	⋮	⋮	
1000 0000 0000 0001	8001	-32767	-15000 or less	

Output current of IR Sensor (pA) = 0.4578 × Measurement data of IR Sensor (Decimal)

## 7). TMP: Measurement data of Temperature Sensor (Read Only Register)

Address	Name	D7	D6	D5	D4	D3	D2	D1	D0
07H	TMPL	TMP[7]	TMP[6]	TMP[5]	TMP[4]	TMP[3]	TMP[2]	TMP[1]	TMP[0]
08H	TMPH	TMP[15]	TMP[14]	TMP[13]	TMP[12]	TMP[11]	TMP[10]	TMP[9]	TMP[8]
Reset		0	0	0	0	0	0	0	0

Measurement data of Integrated Temperature Sensor

TMP[7:0]: Lower 8-bit of output data

TMP[15:8]: Upper 8-bit of output data

16-bit data is stored in 2's compliment format.

Table 13.3. Measurement data of Temperature Sensor(2's compliment)

Measurement data of Temperature Sensor [15:0]			Temperature	Unit
Bin	Hex	Dec		
0111 1111 1111 1111	7FFF	32767	90 or more	°C
⋮	⋮	⋮	⋮	
0011 0001 0011 1011	313B	12603	50	
⋮	⋮	⋮	⋮	
0000 0000 0000 0001	0001	1	25.00198	
0000 0000 0000 0000	0000	0	25	
1111 1111 1111 1111	FFFF	-1	24.99802	
⋮	⋮	⋮	⋮	
1001 0011 1011 0010	93B2	-27726	-30	
⋮	⋮	⋮	⋮	
1000 0000 0000 0001	8001	-32767	-40 or less	

Indicated value of Temperature Sensor (°C) =

$$0.0019837 \times \text{Measurement data of Temperature Sensor (Decimal)} + 25$$

## 8). ST2: Status 2 (Read Only Register)

Address	Name	D7	D6	D5	D4	D3	D2	D1	D0
09H	ST2	1	1	1	HBDR2	1	1	1	DOR
Reset		1	1	1	0	1	1	1	0

Note:

ST2 register must be read out after reading out measurement data. Otherwise, measurement data would not be updated.

HBDR2: Human Approach Detection result 2

“0”: Initial Value (default)

“1”: Human Approach Detect

HBDR2 bit indicates Human Approach Detection result when finish receiving measurement buffer data.

DOR: Data Overrun

“0”: Normal State (default)

“1”: Data Overrun

DOR changes to “1” when data skipping happens, and returns to “0” after reading out ST2 register.

## 9). ST3: Status 3 (Read Only Register)

Address	Name	D7	D6	D5	D4	D3	D2	D1	D0
0AH	ST3	1	1	1	HBDR3	SBNMB[3]	SBNMB[2]	SBNMB[1]	SBNMB[0]
Reset		1	1	1	0	0	0	0	0

HBDR3: Human Approach Detection result 3

“0”: Initial Value (default)

“1”: Human Approach Detect

HBDR3 bit becomes “1” when detecting a human approach. It returns to “0” when readout of the measurement data buffer is completed.

SBNMB[3:0]: Number of Valid Data in SB (Streaming Buffer)

“0”: Initial Value (default)

“N”: Data until SB[N-1]L, SB[N-1]H are valid

SBNMB[3:0] bits show the number of stored measurement data of SB. The default value is 0 and the value increments by 1 until 10 by storing measurement result each time. When SBNMB[3:0] bits value is N (≠0), valid measurement result is from SB[0] to SB[N-1].

## 10). SBL, SBH: Streaming Buffer (Read Only Register)

Address	Name	D7	D6	D5	D4	D3	D2	D1	D0
0BH	SB0L	SB0[7]	SB0[6]	SB0[5]	SB0[4]	SB0[3]	SB0[2]	SB0[1]	SB0[0]
0CH	SB0H	SB0[15]	SB0[14]	SB0[13]	SB0[12]	SB0[11]	SB0[10]	SB0[9]	SB0[8]
⋮	⋮	⋮							
15H	SB5L	SB5[7]	SB5[6]	SB5[5]	SB5[4]	SB5[3]	SB5[2]	SB5[1]	SB5[0]
16H	SB5H	SB5[15]	SB5[14]	SB5[13]	SB5[12]	SB5[11]	SB5[10]	SB5[9]	SB5[8]
⋮	⋮	⋮							
1DH	SB9L	SB9[7]	SB9[6]	SB9[5]	SB9[4]	SB9[3]	SB9[2]	SB9[1]	SB9[0]
1EH	SB9H	SB9[15]	SB9[14]	SB9[13]	SB9[12]	SB9[11]	SB9[10]	SB9[9]	SB9[8]
Reset		0	0	0	0	0	0	0	0

Measurement result is stored here.

Initial values are all “0”.

## 11). ST4: Status 4 (Read Only Register)

Address	Name	D7	D6	D5	D4	D3	D2	D1	D0
1FH	ST4	1	1	1	HBDR4	1	1	1	1
Reset		1	1	1	0	1	1	1	1

HBDR4: Human Approach Detection result 4

“0”: Initial Value (default)

“1”: Human Approach Detect

HBDR4 bit indicates Human Approach Detection result of when finish receiving SB0 data.

## 12). CNTL1: Soft Reset (Read/Write Register)

Address	Name	D7	D6	D5	D4	D3	D2	D1	D0
20H	CNTL1	1	1	1	1	1	1	1	SRST
Reset		1	1	1	1	1	1	1	0

SRST: Soft Reset

“0”: Normal State

“1”: Reset

Analog circuit, INTN output, SDA output and all registers are reset when setting “1” to SRST.

SRST automatically returns to “0” after reset.

It is possible to write CNTL1 during measurement.

## 13). CNTL2: Synchronization Mode Setting (Write/Read Register)

Address	Name	D7	D6	D5	D4	D3	D2	D1	D0
21H	CNTL2	1	1	1	1	1	1	SYNCM [1]	SYNCM [0]
Reset		1	1	1	1	1	1	0	0

SYNCM[1:0]: Synchronization Mode Setting

“00”: No Synchronization (default)

“01”: Master Synchronized

“10”: Slave Synchronized

“11”: Do Not Use

## 14). CNTL3: Low-noise Mode, ODR, Filter Cutoff Frequency Setting (Write/Read Register)

Address	Name	D7	D6	D5	D4	D3	D2	D1	D0
22H	CNTL3	1	LNM	ODR[1]	ODR[0]	FCTMP[1]	FCTMP[0]	FCIR[1]	FCIR[0]
Reset		1	0	1	0	1	0	0	1

LNM: Low Noise Mode

“0”: Low-noise Mode Disable (default)

“1”: Low-noise Mode Enable

ODR[1:0]: Data Output Rate(Frequency) Setting

“00”: ODR 1 Hz

“01”: ODR 2 Hz

“10”: ODR 10 Hz (default)

“11”: ODR 50 Hz

FCTMP[1:0]: Low Pass Filter Cutoff Frequency (Fc) Setting for internal temperature sensor

“00”: No Filter

“01”: Fc =0.9 Hz

“10”: Fc =0.445 Hz (default)

“11”: Do Not Use

This setting is only valid when the data output frequency setting is 10 Hz (ODR bit setting).

If the setting of data output frequency is other than 10 Hz, low pass filter is not applied regardless of FCTMP[1:0] bits setting.

FCIR[1:0]: IR Sensor Low Pass Filter Cutoff Frequency (Fc)

“00”: No Fc

“01”: Fc =0.9 Hz (default)

“10”: Fc =0.445 Hz

“11”: Do Not Use

This setting is only valid when the data output frequency setting is 10 Hz (ODR bit setting).If the setting of data output frequency is other than 10 Hz, low pass filter is not applied regardless of FCIR[1:0] bits setting.

## 15). CNTL4: Optimum operation mode setting (Write/Read Register)

Address	Name	D7	D6	D5	D4	D3	D2	D1	D0
23H	CNTL4	1	1	1	1	1	TOPT[2]	TOPT[1]	TOPT[0]
Reset		1	1	1	1	1	1	1	1

TOPT[2]: Automatic threshold adjustment according to signal temperature characteristics.

“0”: Disable

“1”: Enable (default)

TOPT[1:0]: Optimize noise and current consumption with Built-in Temperature Sensor.

“00”: Disable

“01”: Reserved

“10”: Reserved

“11”: Enable (default)



## 16). CNTL5: Offset Setting of Internal Temperature Sensor (Write/Read register)

Address	Name	D7	D6	D5	D4	D3	D2	D1	D0
24H	CNTL5	1	TMPOFS [6]	TMPOFS [5]	TMPOFS [4]	TMPOFS [3]	TMPOFS [2]	TMPOFS [1]	TMPOFS [0]
Reset		1	0	0	0	0	0	0	0

TMPOFS[6:0]: Temperature Sensor Offset Setting

Table 13.4. Temperature Sensor Offset Setting(2's compliment)

TMPOFS[6:0]			Adding Offset	Unit
Bin	Hex	Dec		
011_1111	3F	63	31.5	°C
⋮	⋮	⋮	⋮	
000_0001	1	1	0.5	
000_0000	0	0	0	
111_1111	7F	-1	-0.5	
⋮	⋮	⋮	⋮	
100_0000	40	-64	-32	

Temperature Sensor Offset (°C) = 0.5 × TMPOFS value (Decimal)

## 17). CNTL6: IR Sensor Gain Setting (Write/ Read Register)

Address	Name	D7	D6	D5	D4	D3	D2	D1	D0
25H	CNTL6	1	1	1	IRGAIN[4]	IRGAIN[3]	IRGAIN[2]	IRGAIN[1]	IRGAIN[0]
Reset		1	1	1	1	1	0	1	0

Table 13.5. IR Sensor Gain Setting(2's compliment)

IRGAIN[4:0]			GAIN	Unit
Bin	Hex	Dec		
0_1111	0F	15	205	%
0_1110	0E	14	200	
⋮	⋮	⋮	⋮	
0_0001	1	1	135	
0_0000	0	0	130	
1_1111	1F	-1	125	
⋮	⋮	⋮	⋮	
1_1010	1A	-6	100	
⋮	⋮	⋮	⋮	
1_0000	10	-16	50	

IR Sensor Gain Setting (%) = 5 × IRGAIN Setting Value (Decimal) + 130

## 18). CNTL7: IR Signal Invert Setting, Idling Time Setting (Write /Read Register)

Address	Name	D7	D6	D5	D4	D3	D2	D1	D0
26H	CNTL7	1	1	1	1	IRINV	IDLET[2]	IDLET[1]	IDLET[0]
Reset		1	1	1	1	0	0	0	0

IRINV: Human Approach Detection algorithm input signal Invert Setting

“0”: Normal (default)

“1”: Invert

IDLET[2:0]: Human Approach Detection algorithm Idling Time Setting

“000” : 0 sec (default)

“001” : 5 sec

“010” : 10 sec

“011” : 30 sec

“1XX” : 300 sec

## 19). CNTL8: Detection Time Setting (Write/ Read Register)

Address	Name	D7	D6	D5	D4	D3	D2	D1	D0
27H	CNTL8	1	DTCT[6]	DTCT[5]	DTCT[4]	DTCT[3]	DTCT[2]	DTCT[1]	DTCT[0]
Reset		1	0	0	0	0	0	0	1

The AK9754 detects a human approach when the Human Approach Detection signal exceeds the threshold of internal algorithm for the number of samples set by DTCT[6:0] bits.

DTCT[6:0]: Detection Time Setting

“0000000”: 1 time

“0000001”: 1 time (default)

“0000010”: 2 times

⋮

“1111111”: 127 times

## 20). CNTL9: Threshold of Human Approach Detection Algorithm (Lower) Setting (Write/Read Register)

Address	Name	D7	D6	D5	D4	D3	D2	D1	D0
28H	CNTL9	HBDTH[7]	HBDTH[6]	HBDTH[5]	HBDTH[4]	HBDTH[3]	HBDTH[2]	HBDTH[1]	HBDTH[0]
Reset		0	0	1	0	1	1	0	0

Threshold of Human Approach Detection Algorithm (Lower)

default: HBDTH[14:0] bits = 012Ch

## 21). CNTL10: Threshold of Human Approach Detection Algorithm (Upper) Setting (Write/Read Register)

Address	Name	D7	D6	D5	D4	D3	D2	D1	D0
29H	CNTL10	1	HBDTH [14]	HBDTH [13]	HBDTH [12]	HBDTH [11]	HBDTH [10]	HBDTH [9]	HBDTH [8]
Reset		1	0	0	0	0	0	0	1

Threshold of Human Approach Detection Algorithm (Upper)

default: HBDTH[14:0] bits = 012Ch

## 22). CNTL11: Detailed Setting of Human Approach Detection Algorithm (Write/Read Register)

Address	Name	D7	D6	D5	D4	D3	D2	D1	D0
2AH	CNTL11	1	1	1	HBDEN	SBHBD	SBEN	HBDIEN	DRIEN
Reset		1	1	1	0	0	0	0	0

HBDEN: Human Approach Detection Enable

“0”: Human Approach Detection Algorithm OFF (default)

“1”: Human Approach Detection Algorithm ON

SBHBD: Update of Streaming Buffer (SB) by Human Approach Detection

“0”: Do Not Stop Updating SB (default)

“1”: Stop Updating SB

SBEN: Streaming Buffer (SB) Enable

“0”: SB OFF (default)

“1”: SB ON

Valid/Invalid setting of SB operation. This bit becomes “0” automatically when SB is stopped by Human Approach Detection.

HBDIEN: Interrupt Enable on Human Sensing

“0”: Interrupt Setting Disable (default)

“1”: Interrupt Setting Enable

Interrupt setting with Human Approach Detection is available.

DRIEN: Interrupt Enable on Data Ready

“0”: Interrupt Setting Disable (default)

“1”: Interrupt Setting Enable

Interrupt setting with Data ready status is available.

It is possible to write CNTL11 during measurement.

## 23). It is possible to write CNTL11 during measurement. CNTL12: Mode Setting (Write/Read Register)

Address	Name	D7	D6	D5	D4	D3	D2	D1	D0
2BH	CNTL12	1	1	1	1	1	1	1	MODE
Reset		1	1	1	1	1	1	1	0

MODE: Operation Mode Setting

“0”: Stand-by Mode (default)

“1”: Continuous Measurement Mode

It is possible to write CNTL12 during measurement.

14. Spectrum Sensitivity (Reference)

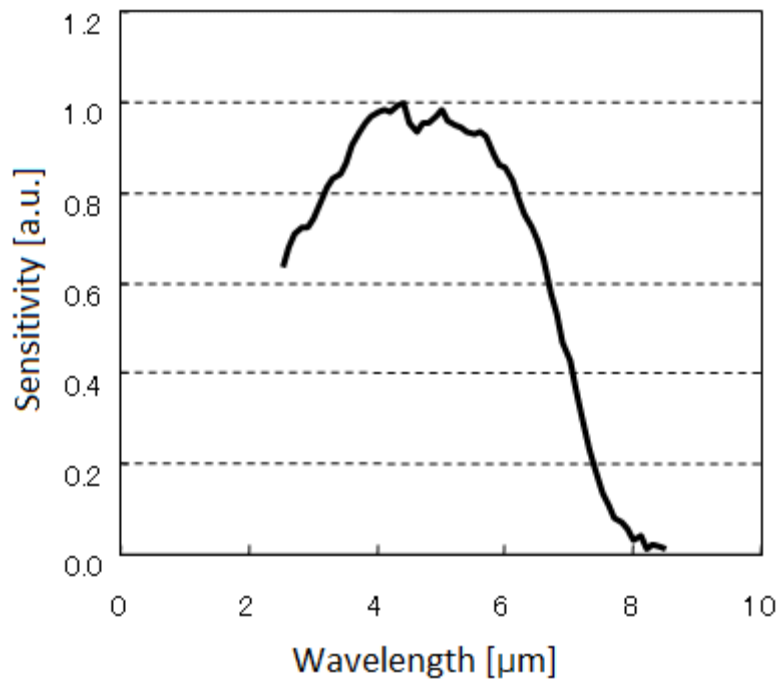

Figure 14.1. Spectrum Sensitivity

**15. Field of View (Reference)**

Field of View (FOV) of sensor itself is 180°. On the other hand, actual FOV is determined and limited by a hole in a mounting board. Measurement result is shown below in case that the hole is designed for FOV to be 115° (Typ.).

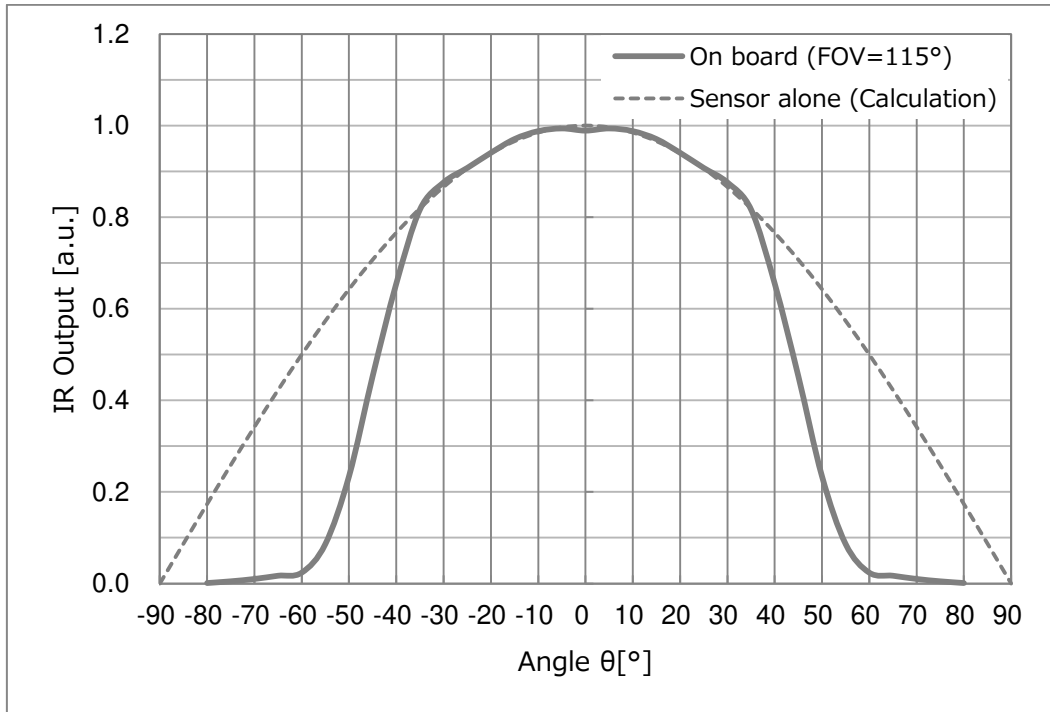

Figure 15.1. Field of View

[Measurement Conditions]

Ambient temperature (Ta)	25°C
Light source	Cavity Blackbody $\Phi 22.2\text{mm}$ , 500K
Field of View (FOV)	115° (determined by a hole)
Distance between sensor and light source	100mm

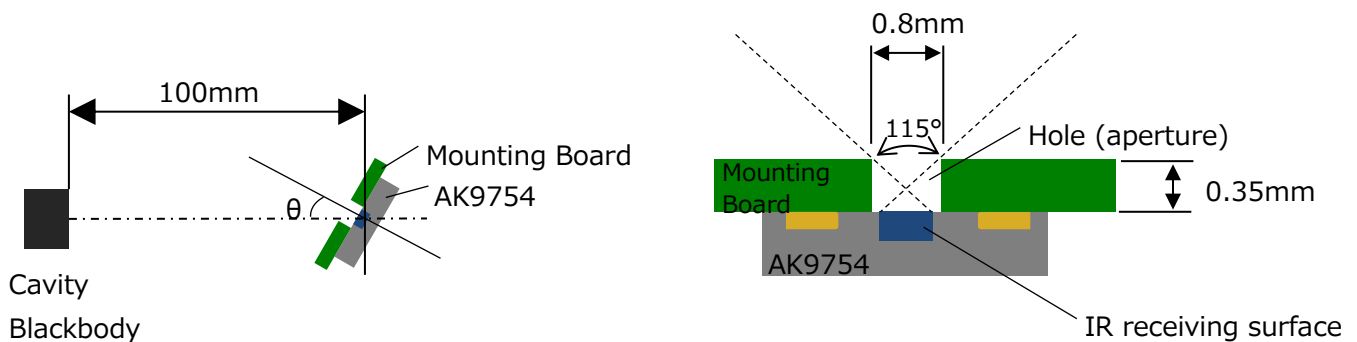

Figure 15.2. Measurement Environment

**16. IR Sensor Output Characteristics (Reference)**

A relationship between the object temperature ( $T_{obj}$ ) and IR sensor output code is shown below. These are reference values of when the ambient temperature ( $T_a$ ) is 25 °C and Field of View (FOV) of the sensor is 115 °.

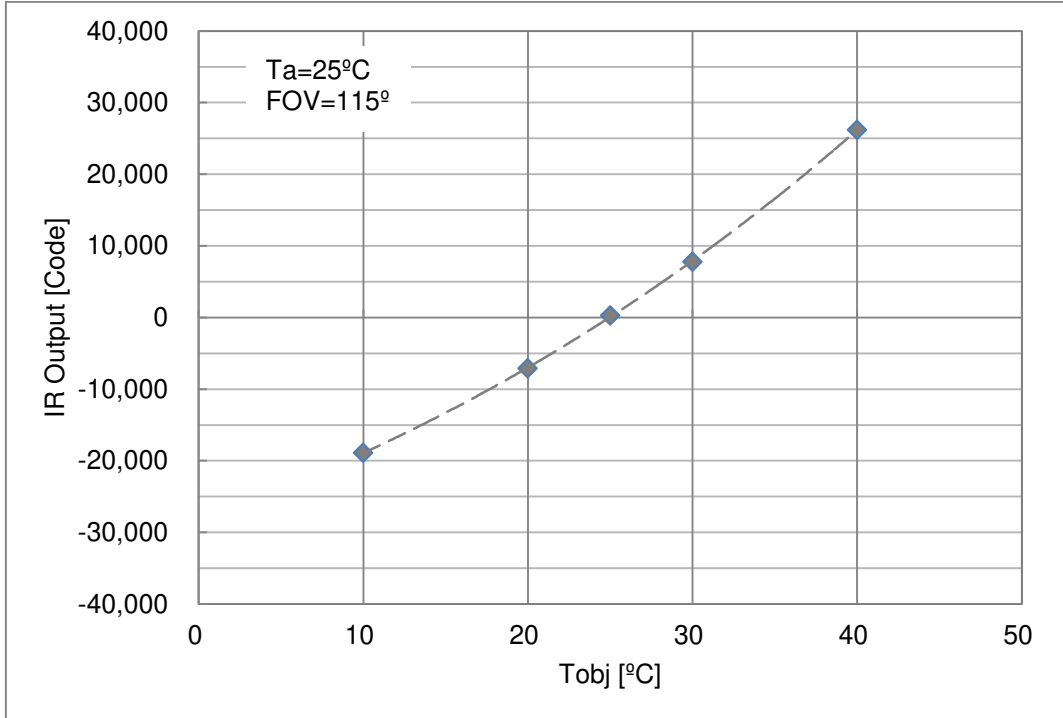

Figure 16.1. IR Sensor Output Characteristics

[Measurement Conditions]

Ambient Temperature ( $T_a$ )	25°C
Light Source	Cavity Blackbody
Field of View (FOV)	115 ° (Determined by a hole)
Distance between sensor and light Source	20mm

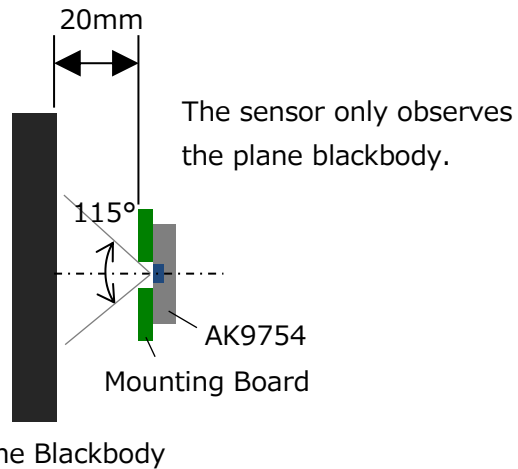
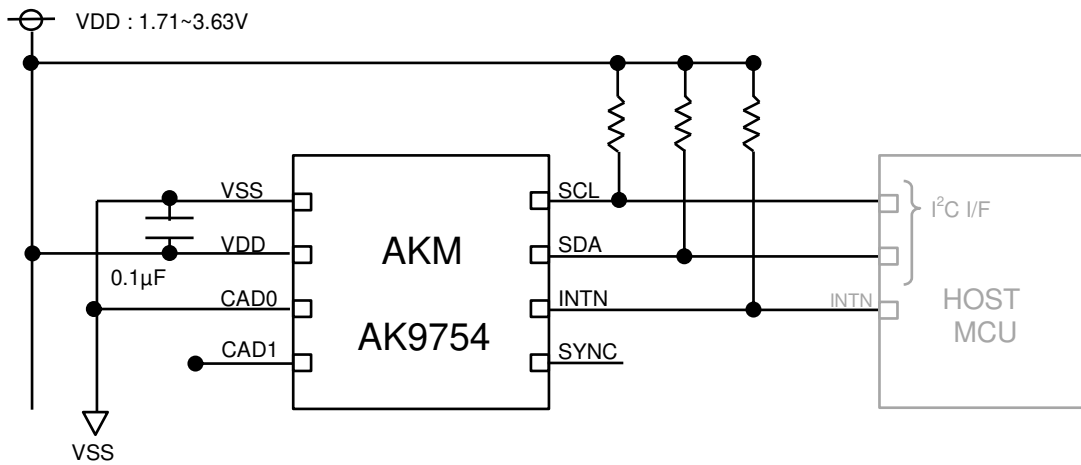

Figure 16.2. IR Sensor Output Measurement Environment

**17. Recommended External Circuits**



\*When CAD0, CAD1 pin are not connected, the allowable load capacitance is less than 3pF.

Figure 17.1. AK9754 Recommended External Circuit 1

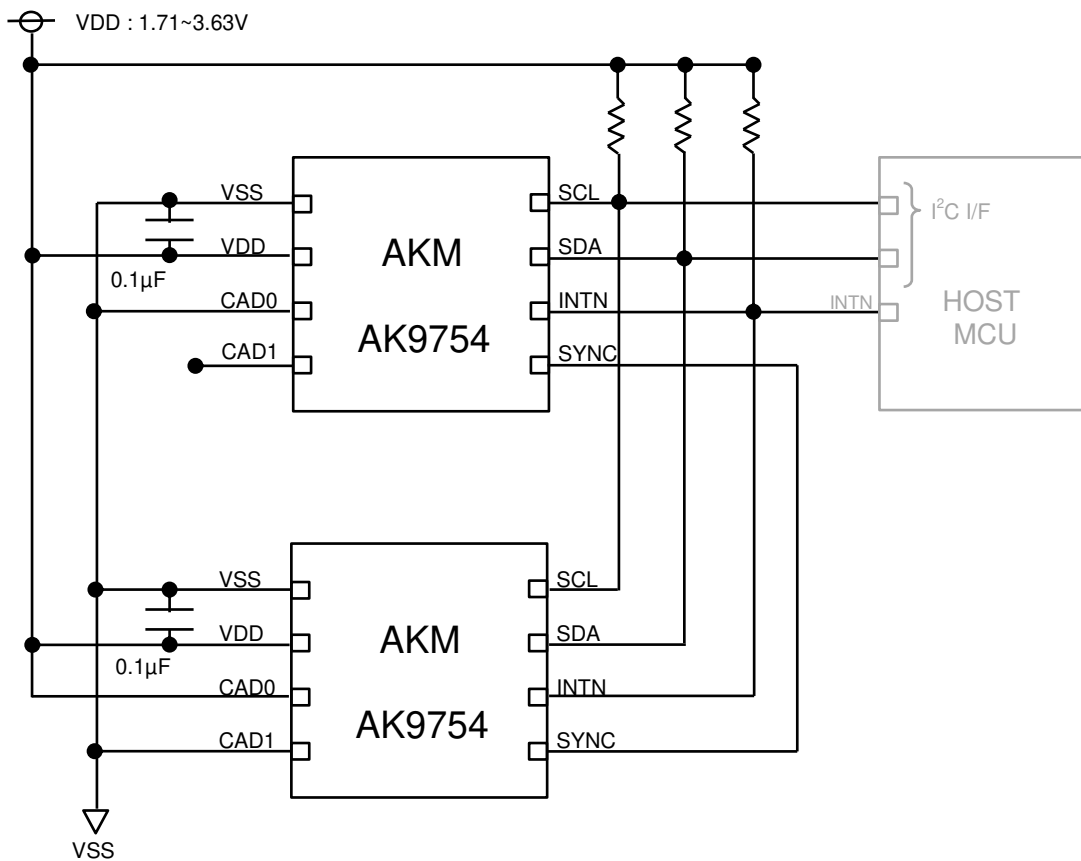

\*When CAD0, CAD1 pin are not connected, the allowable load capacitance is less than 3pF.

\*The allowable wiring capacitance of SYNC pin is less than 50 pF.

Figure 17.2. AK9754 Recommended External Circuit 2

Note: When using different power supplies, check the MCU specifications.

**18. Package**

**18.1. Outline Dimensions**

8-pin SON (Unit: mm)

Unless otherwise specified :  $\pm 0.1$ mm

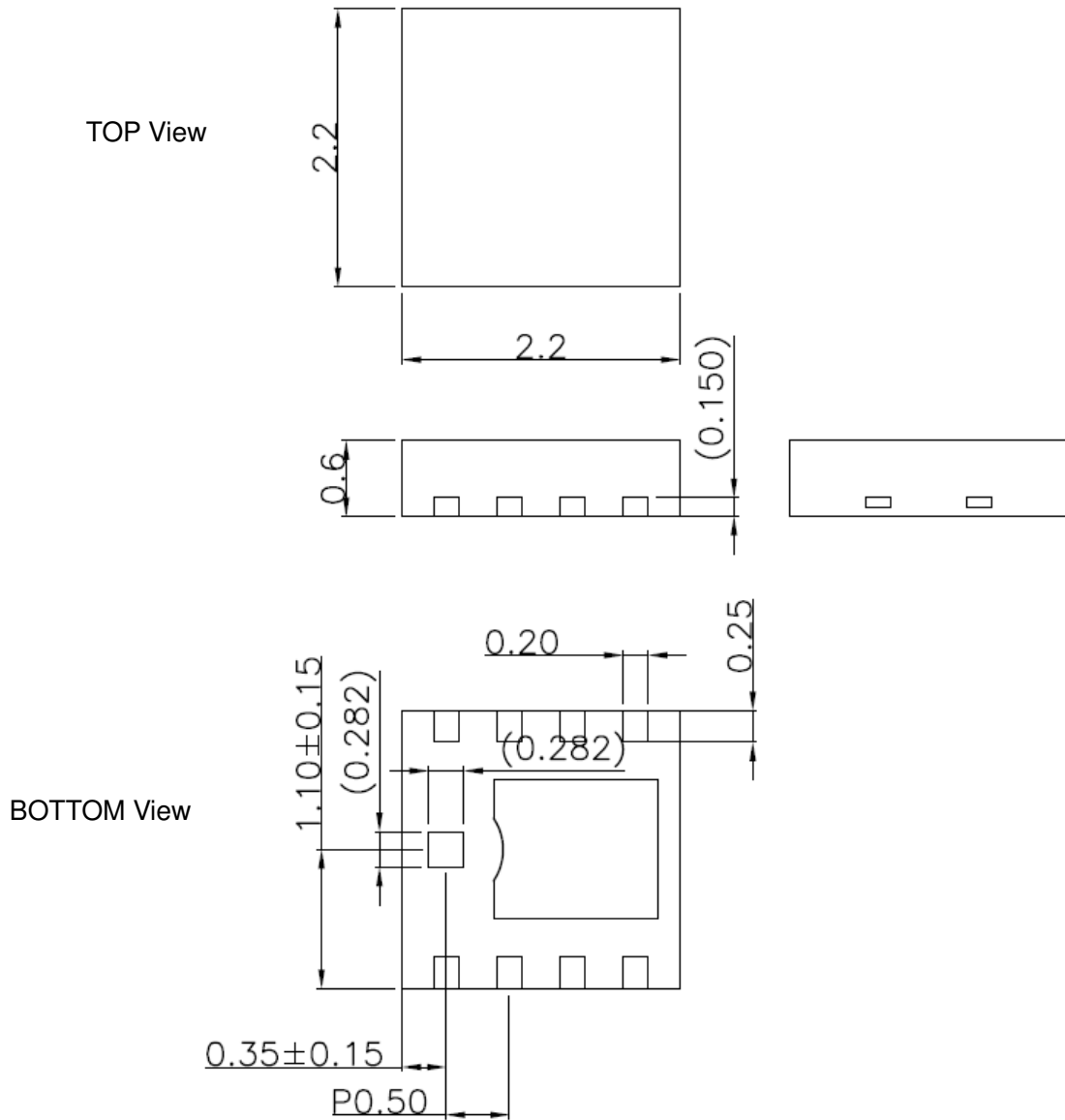

Figure 18.1. AK9754 Outline Dimensions



18.2. Pad dimensions

(Unit: mm)

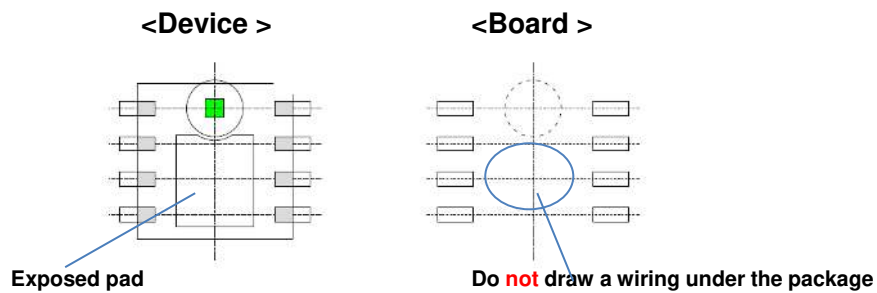
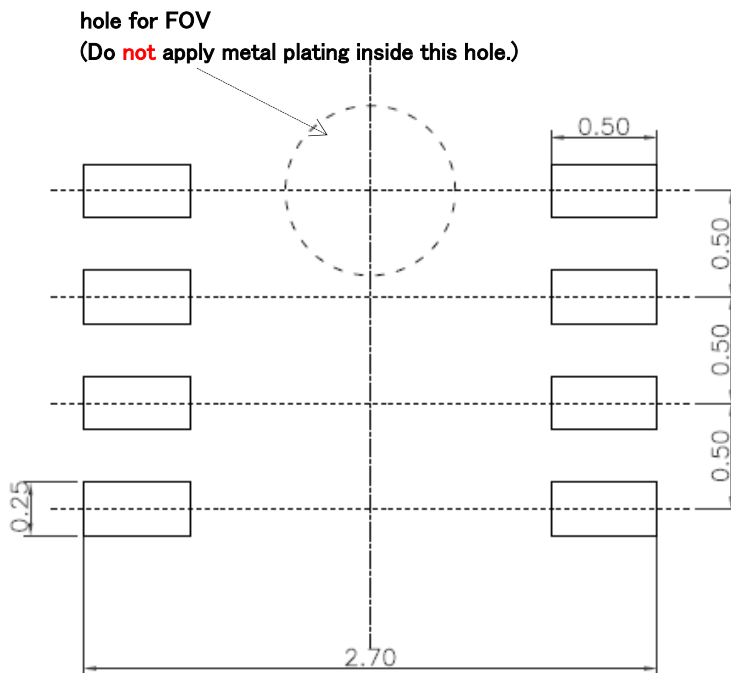

Figure 18.2. AK9754 Land Pattern

Note:

- The exposed pad on the bottom surface of the package must not be soldered on the board.
- It is necessary to make a hole through the board FOV.  
Do not apply plating at the inside of this hole.
- The exposed pad is internally connected to the VSS.  
Do not draw a wiring under the package to avoid shorting with the exposed pad.

**18.3. Marking**

IR receiving surface is on the opposite side of the marking surface.

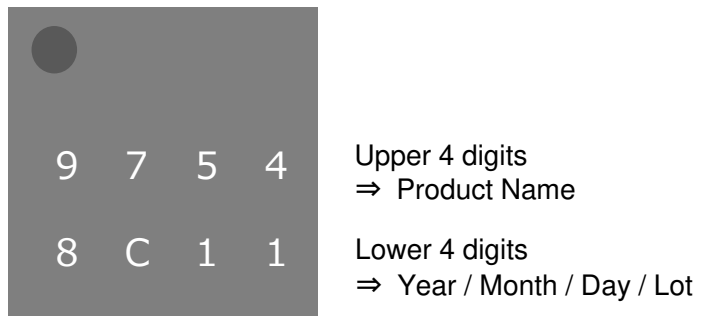

Figure 18.3. AK9754 Marking

**19. Orgering Guide**

AK9754AE      -30 to 85°C      8-pin SON

**20. Revision History**

Date (Y/M/D)	Revision	Reason	Page	Contents
			-	-

**IMPORTANT NOTICE**

0. Asahi Kasei Microdevices Corporation ("AKM") reserves the right to make changes to the information contained in this document without notice. When you consider any use or application of AKM product stipulated in this document ("Product"), please make inquiries the sales office of AKM or authorized distributors as to current status of the Products.
1. All information included in this document are provided only to illustrate the operation and application examples of AKM Products. AKM neither makes warranties or representations with respect to the accuracy or completeness of the information contained in this document nor grants any license to any intellectual property rights or any other rights of AKM or any third party with respect to the information in this document. You are fully responsible for use of such information contained in this document in your product design or applications. AKM ASSUMES NO LIABILITY FOR ANY LOSSES INCURRED BY YOU OR THIRD PARTIES ARISING FROM THE USE OF SUCH INFORMATION IN YOUR PRODUCT DESIGN OR APPLICATIONS.
2. The Product is neither intended nor warranted for use in equipment or systems that require extraordinarily high levels of quality and/or reliability and/or a malfunction or failure of which may cause loss of human life, bodily injury, serious property damage or serious public impact, including but not limited to, equipment used in nuclear facilities, equipment used in the aerospace industry, medical equipment, equipment used for automobiles, trains, ships and other transportation, traffic signaling equipment, equipment used to control combustions or explosions, safety devices, elevators and escalators, devices related to electric power, and equipment used in finance-related fields. Do not use Product for the above use unless specifically agreed by AKM in writing.
3. Though AKM works continually to improve the Product's quality and reliability, you are responsible for complying with safety standards and for providing adequate designs and safeguards for your hardware, software and systems which minimize risk and avoid situations in which a malfunction or failure of the Product could cause loss of human life, bodily injury or damage to property, including data loss or corruption.
4. Do not use or otherwise make available the Product or related technology or any information contained in this document for any military purposes, including without limitation, for the design, development, use, stockpiling or manufacturing of nuclear, chemical, or biological weapons or missile technology products (mass destruction weapons). When exporting the Products or related technology or any information contained in this document, you should comply with the applicable export control laws and regulations and follow the procedures required by such laws and regulations. The Products and related technology may not be used for or incorporated into any products or systems whose manufacture, use, or sale is prohibited under any applicable domestic or foreign laws or regulations.
5. Please contact AKM sales representative for details as to environmental matters such as the RoHS compatibility of the Product. Please use the Product in compliance with all applicable laws and regulations that regulate the inclusion or use of controlled substances, including without limitation, the EU RoHS Directive. AKM assumes no liability for damages or losses occurring as a result of noncompliance with applicable laws and regulations.
6. Resale of the Product with provisions different from the statement and/or technical features set forth in this document shall immediately void any warranty granted by AKM for the Product and shall not create or extend in any manner whatsoever, any liability of AKM.
7. This document may not be reproduced or duplicated, in any form, in whole or in part, without prior written consent of AKM.

**Rev.1**