



We are dedicated to developing sensing technology, and providing customers with an innovative and diverse range of sensor products.

Our sensors and state-of-the art fingerprint recognition algorithm technologies provide advanced and convenient fingerprint acquisition and verification.

MFC-2160KM Fingerprint
Module Data Sheet

Midas Touch, Inc.

17F-16, No. 1, Sec. 1, Zhongshan Rd., Banqiao Dist.,
New Taipei City 22063, Taiwan (R.O.C.)

Email: support@midastouchinc.com

Tel : +886-2-8953-0862

Fax : +886-2-2952-8441



[DESCRIPTION]

The MFC-2160KM fingerprint sensor module is consist from MFC-2160KM fingerprint sensor & Algorithm MCU. The module provides one UART interface output port for connecting to customer side main board.

The operation of MFC-2160KM is as following, a fingerprint image captured by pixel array, delivery fingerprint ridge or valley signals to A/D converter and digital processor, then to the serial peripheral interface for data-reading. Due to MCU already installed fingerprint algorithm, the user can through UART interface use MCU SOC command to operate module like fingerprint enroll, match operations etc.

[FEATURES]

- *160x160 pixels*
- *Build-in ADC for digitizing image*
- *UART interface*
- *Data encryption*
- *Short read out time*
- *Cost effective sensor*
- *High sensing capability*
- *Single power supply*

[APPLICATIONS]

- *Door lock*
- *Security device*
- *Access control system*



Table of Contents

1	Electrical Characteristics	4
1.1	Maximum rating	4
1.2	Operation condition	4
2	Specification	5
3	Mechanical Specification	6
3.1	Connector Pin Description	6
3.2	Connector Information	7
3.3	Package size.....	8
3.4	Outline Reference.....	9
4	SDK Guide	10
4.1	UART setting.....	10
4.2	Initial time	10
4.3	Command protocol.....	10
4.4	Hardware connection	10
5	Revision history	11



1 Electrical Characteristics

1.1 Maximum rating

Symbol	Parameter	Conditions	Value	Unit
VDD	Supply voltage		4	V
TA	Operating temperature		-40 to 80	°C
ST	Storage temperature		-40 to 125	°C

1.2 Operation condition

Symbol	Parameter	Conditions	Min.	Typ	Max	Unit
VDD	Supply voltage		2.8	3.3	3.6	V
Touch_VCC	Supply voltage		2.8	3.3	3.6	V
IDD	Total supply current	Capture mode: VDD power on			35	mA
IDD	Supply current	Standby mode: VDD power on, wait for command	—	—	18	mA
IDD	Touch supply current	Sleep mode: Finger detection active, VDD power off.			10	uA
ESDKV	ESD protection	Air mode	—	±15	—	kV

Note : The ESD criteria is to pass internal final test criteria after ESD testing.



2 Specifications

Item	Value
Image resolution	508dpi
Sensing area	8mm x 8mm
Sensing array	160 x 160 pixels
Package size	15.8mm x 14.5mm x 3 mm(H)
Gray Level	8 bits/pixels ,256 gray scales
Recognition Time	1:N , < 0.6 second
Template capacity	100
FRR(False Rejection Rate)	1.5%
FAR(False Acceptance Rate)	<0.01‰
Interface	UART (57600,8,N,2) / TTL level
Supply voltage	3.3V
Total supply current	35mA
Operating Humidity	0 - 95% , Non-condense
Operating temperature	-40 to +80 °C
ESD protection for air discharging	15kV



3 Mechanical Specification

3.1 Connector Pin Description

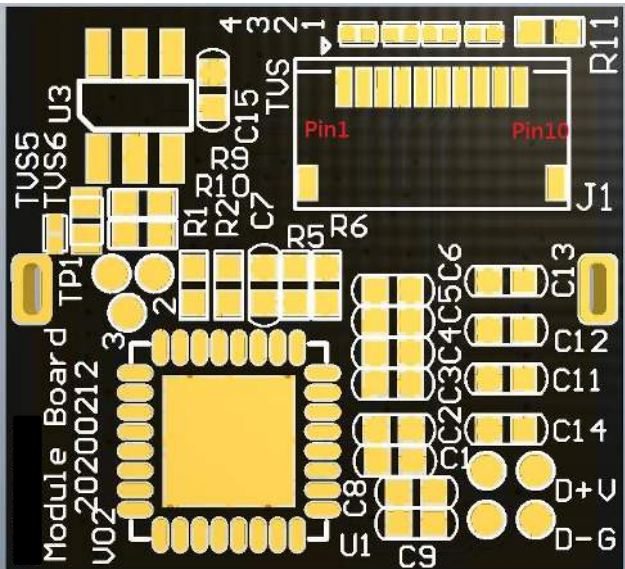
Pin Order	Pin Name	Type	Pin Description	
1	Touch_Out	Output	Touch signal output. Active output high.	<p style="text-align: center;">Bottom View</p> 
2	Touch_VCC	Power In	Module Touch function power input pin. Supply 3.3V	
3	VDD	Power In	Module power input pin. Supply 3.3V	
4	UART_TX	Output	Module UART transmission pin.	
5	UART_RX	Input	Module UART reception pin.	
6	USBDN	I/O	USBD-	
7	USBDP	I/O	USBD+	
8	GND	Ground	Module system ground.	
9	GND	Ground	Module system ground.	
10	ESD_GND	Ground	Module system ground for ESD path. Connect to ground	



3.2 Connector Information

Connector model: 10 pin, pitch 0.5mm FPC connector

RoHS Compliant

HALOGEN FREE

NOTES:

- MATERIAL:**
HOUSING: HIGH-TEMP PLASTIC, UL 94-V0, COLOR: NATURAL
COVER: HIGH-TEMP PLASTIC, UL 94-V0, COLOR: BLACK
CONTACT: Phosphor Bronze
LEG: Brass
- PLATING:**
CONTACT: GOLD ON NICKEL OVERALL
LEG: TIN PLATED ON NICKEL OVERALL
- RATING:**
CURRENT RATING: 0.5A AC/DC
VOLTAGE RATING: 50V AC/DC
TEMPERATURE RANGE: -55°C~+85°C
Withstand Voltage: 200V AC/Minute
Contact Resistance: ≤ 40M Ω
Insulation Resistance: ≥ 50M Ω

PIN NO.	DIM. A	DIM. B	DIM. C	DIM. D	PIN NO.	DIM. A	DIM. B	DIM. C	DIM. D
04	3.77	1.50	2.60	3.27	23	13.27	11.50	12.10	12.77
05	4.27	2.00	3.10	3.77	24	13.77	11.50	12.60	13.27
06	4.77	2.50	3.60	4.27	25	14.27	12.00	13.10	13.77
07	5.27	3.00	4.10	4.77	26	14.77	12.50	13.60	14.27
08	5.77	3.50	4.60	5.27	27	15.27	13.00	14.10	14.77
09	6.27	4.00	5.10	5.77	28	15.77	13.50	14.60	15.27
10	6.77	4.50	5.60	6.27	29	16.27	14.00	15.10	15.77
11	7.27	5.00	6.10	6.77	30	16.77	14.50	15.60	16.27
12	7.77	5.50	6.60	7.27	31	17.27	15.00	16.10	16.77
13	8.27	6.00	7.10	7.77	32	17.77	15.50	16.60	17.27
14	8.77	6.50	7.60	8.27	33	18.27	16.00	17.10	17.77
15	9.27	7.00	8.10	8.77	34	18.77	16.50	17.60	18.27
16	9.77	7.50	8.60	9.27	35	19.27	17.00	18.10	18.77
17	10.27	8.00	9.10	9.77	36	19.77	17.50	18.60	19.27
18	10.77	8.50	9.60	10.27	37	20.27	18.00	19.10	19.77
19	11.27	9.00	10.10	10.77	38	20.77	18.50	19.60	20.27
20	11.77	9.50	10.60	11.27	39	21.27	19.00	20.10	20.77
21	12.27	10.00	11.10	11.77	40	21.77	19.50	20.60	21.27
22	12.77	10.50	11.60	12.27	n	n*0.5+1.77	(n-1)*0.5	n*0.5+0.6	n*0.5+1.27

RECOMMEND PCB LAYOUT TOLERANCE: ±0.05

FFC cable recommend

項目(Item)	規格值(Specification)	
導體芯數 (NO. of conductors)	N	xx
間距(Pitch)	P	0.5±0.05
全間距(Full Pitch)	PT	P*(N-1) (±0.1)
總長度(Full Length)	L	xxxx
絕緣長度(Insulation Length)	IL	L-S1-S2
邊緣寬度(Margin Width)	M	0.5±0.05
總寬度(Full width)	W	P*(N+1) (±0.1)
線口長度(Strip Length)	S1	2±1
線口長度(Strip Length)	S2	2±1
補強板長度(Reinforeing tape length)	B1	4±1
補強板長度(Reinforeing tape length)	B2	4±1
線口傾斜度(Slanting)	A	≤0.3
沖孔(Over lap)	A1	≤0.5
插入厚度(Terminal thickness)	t	0.30±0.05
線身厚度(Thickness insulation)	t1	0.12±0.02
導體厚度(Conductor thickness)	Ct	0.035±0.005
導體寬度(Conductor width)	Cw	0.3±0.05
補強板顏色(Supporting Tapc Color)		藍色(Blue)
補強板規格(PET(Supporting Tapc Color))		0.225mm
絕緣膠規格(PET(Insulation))-印字		0.043mm
絕緣膠規格(PET(Insulation))-白色		0.043mm
導體鍍層(Conductor plating)		鍍錫(Tin Plating)

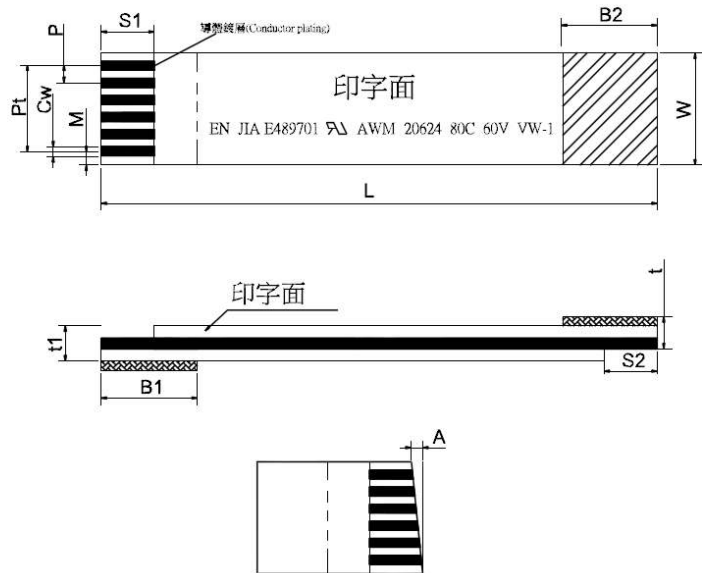



3.3 Package size

Fingerprint module size

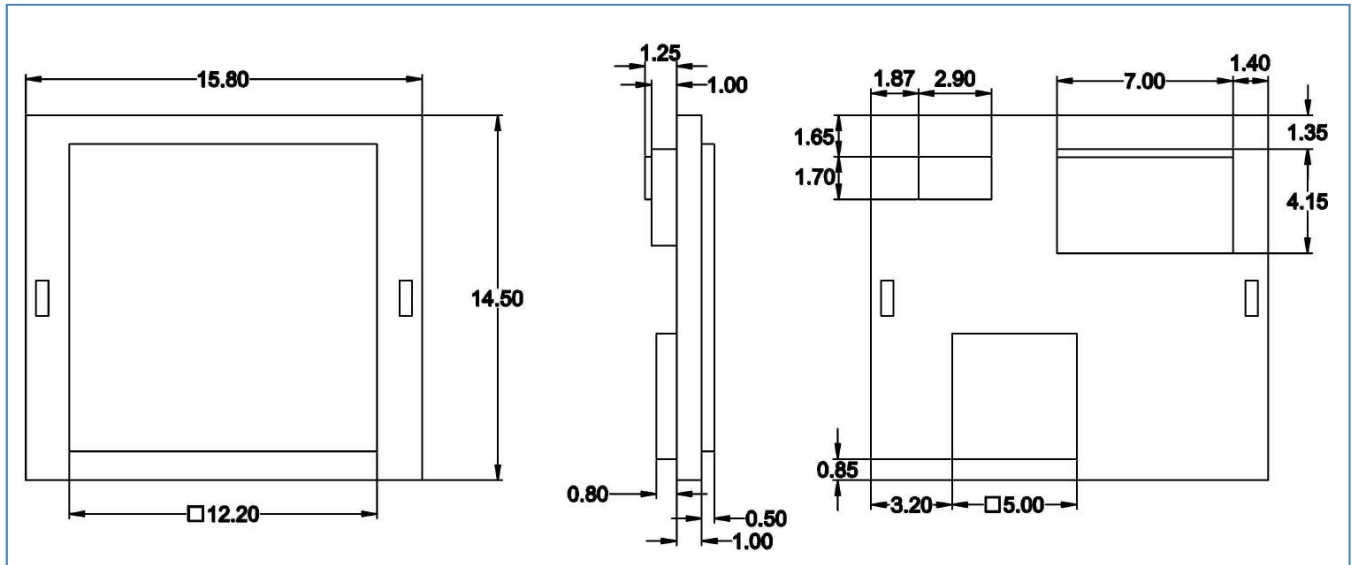

Fingerprint sensor bezel size

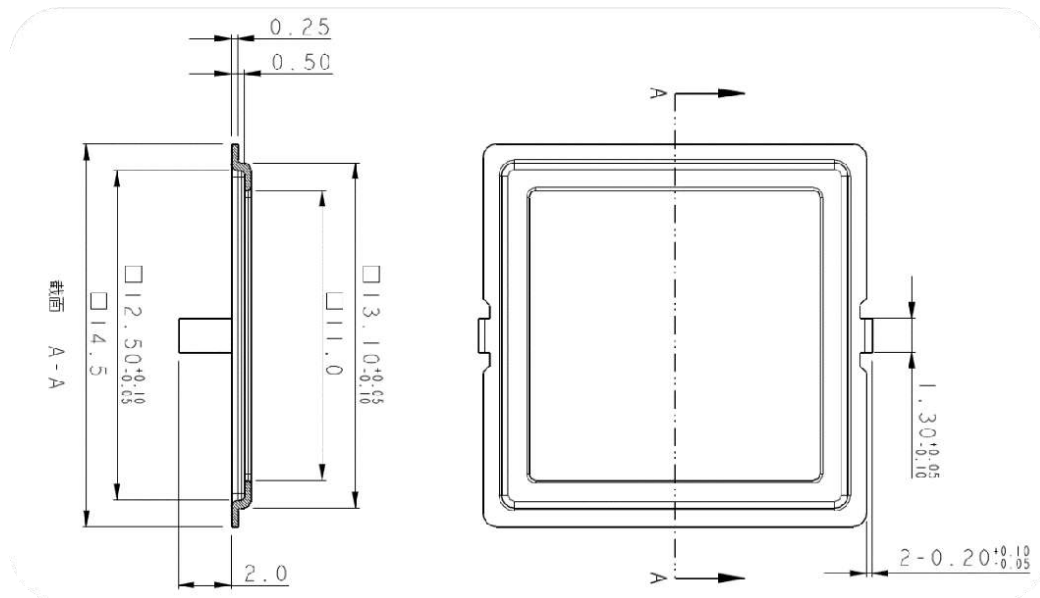



3.4 Outline Reference

<Top view>



<Bottom view>

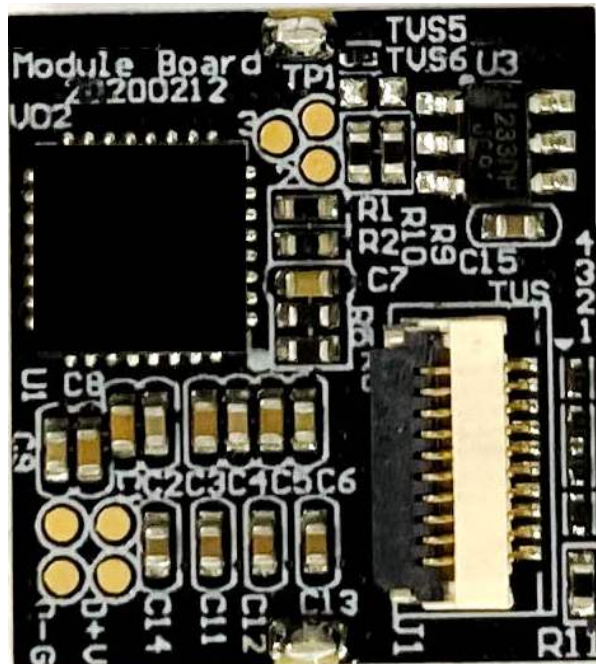



4 SDK Guide

4.1 UART setting

UART default baud rate : 57600

Data format: 8 bits of data, No parity, 2 stop bits

4.2 Initial time

After VDD 3.3v Power on, the module initial time about 100ms.

Module will send 0x55 data to Host by UART TX after initial finish.

The module would not response Host command at initial time.

4.3 Command protocol

Please refer the Protocol User Manual document.

4.4 Hardware connection

Pin 1: Touch function output signal, when finger on MFC-2160KM module would be High signal. Pin1 connect to main board MCU GPIO pin to received signal. When Host MCU got the signal means someone touch and want wake up system, then supply 3.3V to pin3 fingerprint module.

Pin 2: Touch function power, always supply 3.3V.

Pin 3: Supply 3.3V when you want to using fingerprint module function. After finish all fingerprint function then cutting 3.3V to save power

Pin 4: Connect to Host MCU UART_RX pin

Pin 5: Connect to Host MCU UART_TX pin

Pin 6: Reserved

Pin 7: Reserved

Pin 8~10: Connect to main board ground.



5 Revision history

Version	Date	Changes	Approved	Checked	Author
V1.0	2019/12/19	Initial draft	Angus Chou	Hyde Wu	Hyde Wu
V1.1	2020/03/09	Add connector info and size modify	Angus Chou	Hyde Wu	Hyde Wu
V1.2	2020/05/15	Add Standby Touch supply current	Angus Chou	Hyde Wu	Hyde Wu