



20DMWE_1.5 Series

20W - Single Output - Ultra Wide Input - Isolated & Regulated DC-DC Converter

DC-DC Converter

20 Watt

- ⊕ Wide 2:1 input voltage range
- ⊕ High efficiency up to 91%
- ⊕ Short circuit protection (SCP)
- ⊕ Input/output isolation voltage: 1.5K Vdc
- ⊕ 20W DIL PACKAGE
- ⊕ RoHS compliant
- ⊕ Operating temperature range: -40°C to +105°C
- ⊕ International standard pin-out
- ⊕ Input under-voltage, output over-current, over-voltage protection
- ⊕ Chassis and rail mounting products featuring anti-reverse connection for input

The 20DMWE_1.5 series are isolated 20W DC/DC products with 2:1 input voltage. They feature efficiency up to 91%, 1500VDC isolation, operating temperature of -40°C to +105°C, input under-voltage protection, output over-voltage, output over-current, output short circuit protection, which make them widely applied in industrial control, electric power, instruments and communication fields.

The extension packages chassis mounting and rail mounting also enable them with reverse voltage protection.



Common specifications	
Short circuit protection:	Hiccup, continuous, self recovery
Cooling:	Free air convection
Operation temperature range:	• 3.3V/5V: -40°C~+95°C • Others: -40°C~+105°C
Storage temperature range:	-55°C~+125°C
Lead temperature:	300°C MAX, 1.5mm from case for 10 sec.
Storage humidity range:	5%-95% MAX, non-condensing
Safety standards:	EN 60950-1, IEC 60950-1
Vibration and thermal shock:	10-150Hz, 5G, 0.75mm. along X, Y and Z
Case material:	Aluminium alloy
MTBF (MIL-HDBK-217F @25°C):	1000 Khours
Weight:	15g (horizontal) 35g (chassis mounting) 55g (rail mounting)

Input specifications						
Item	Test condition	Min	Typ	Max	Units	
Input reflected ripple current	Nominal input series		30		mA	
Input surge voltage (100ms max.)	• 12V • 24V • 48V		-0.7	25 50 100	V	
Start-up voltage	• 12V • 24V • 48V			9 18 36	VDC	
Under voltage protection	• 12V • 24V • 48V	5.5 12 36	6.5 15.5 30		VDC	
Starting time	Nominal input voltage & constant resistance load		10		ms	
Input filter	Pi filter					
Hot plug	Unavailable					
Ctrl*	• Module switch: ON • Module switch: OFF • Input current when switched off				Ctrl suspended or connected to TTL high level (3.5-12VDC) Ctrl pin connected to GND or low level (0-1.2VDC) 2 7	mA

* The voltage of Ctrl pin is relative to input pin GND.

Output specifications						
Item	Test condition	Min	Typ	Max	Units	
Voltage accuracy	0%-100% load		±1	±3	%	
Line regulation	Vmin to Vmax		±0.2	±0.5	%	
Load regulation	5% -100% load		±0.5	±1.0	%	
Temperature drift	Vout			±0.03	%/°C	
Ripple and noise*	20MHz Bandwidth, 5% -100% load		50	100	mVp-p	
Transient recovery time	25% load step change		300	500	µs	
Transient response deviation	25% load step change • 3.3/5V output • others		±5 ±3	±8 ±5	%	
Trim	Input voltage range	90		110	%Vo	
Over voltage protection	Input voltage range	110		160	%Vo	
Over current protection	Input voltage range	110	150	190	%Io	
Switching frequency	PWM mode • 3.3/5V output • others		300 270		KHz	

* 0%-5% load ripple&Noise is no more than 5%Vo. Ripple and noise are measured by "parallel cable" method, please see DC-DC Converter Application Notes for specific operation.

Isolation specifications						
Item	Test condition	Min	Typ	Max	Units	
Isolation voltage	test time 1min/ leak current <1mA • Input-output • Input/output case	1500 1000			VDC VDC	
Isolation resistance	Test at 500VDC	1000			MΩ	
Isolation capacitance			2000		pF	

Example:

20DMWE_2415S1.5
20=20Watt; D= DIP; M=series; W= wide input (2:1) 18-36Vin; 15Vout;
E= Economy; S= single output; 1.5= 1500VDC

Note:

1. Only typical model listed. Non-standard models will be different from the above, please contact us for more details.
2. All specifications are measured at TA=25°C, humidity<75%, nominal input voltage and rated output load unless otherwise specified.
3. In this datasheet, all the test methods of indications are based on corporate standards.

20DMWE_1.5 Series

20W - Single Output - Ultra Wide Input - Isolated & Regulated DC-DC Converter

EMC specifications

EMI	CE	CISPR32/EN55032	CLASS B	(External Circuit Refer to EMC recommended circuit, ②)
EMI	RE	CISPR32/EN55032	CLASS B	(External Circuit Refer to EMC recommended circuit, ②)
EMS	ESD	IEC/EN61000-4-2	Contact ±6KV, Air ±8KV	perf. Criteria B
EMS	RS	IEC/EN61000-4-3	10V/m	perf. Criteria A
EMS	EFT	IEC/EN61000-4-4	±2KV	perf. Criteria A (External Circuit Refer to recommended circuit, ①)
EMS	Surge	IEC/EN61000-4-5	line to line ±2KV	perf. Criteria B (External Circuit Refer to recommended circuit, ①)
EMS	CS	IEC/EN61000-4-6	3 Vr.m.s	perf. Criteria A

Part Number	Input Voltage [VDC]			Input Current [mA, typ/max]		Output Voltage [VDC]	Output Current [mA]	Efficiency [%, Typ.]	Capacitor load [μF, Max]
	Nominal	Range	Max	no load	full load				
20DMWE_1203S1.5	12	9-18	20	40/70	1599/1637	3.3	5000	86	1000
20DMWE_1205S1.5	12	9-18	20	45/70	1873/1916	5	4000	89	1000
20DMWE_1212S1.5	12	9-18	20	7/20	1873/1916	12	1667	89	1600
20DMWE_1215S1.5	12	9-18	20	7/20	1852/1894	15	1333	90	1000
20DMWE_1224S1.5	12	9-18	20	12/20	1852/1894	24	833	90	500
20DMWE_2403S1.5	24	18-36	40	30/50	782/800	3.3	5000	88	1000
20DMWE_2405S1.5	24	18-36	40	35/55	926/947	5	4000	90	1000
20DMWE_2412S1.5	24	18-36	40	6/15	926/947	12	1667	90	1600
20DMWE_2415S1.5	24	18-36	40	6/15	916/937	15	1333	91	1000
20DMWE_2424S1.5	24	18-36	40	10/20	916/937	24	833	91	500
20DMWE_4803S1.5	48	36-75	80	15/30	391/400	3.3	5000	88	1000
20DMWE_4805S1.5	48	36-75	80	20/30	463/474	5	4000	90	1000
20DMWE_4812S1.5	48	36-75	80	3/15	458/469	12	1667	91	1600
20DMWE_4815S1.5	48	36-75	80	3/15	458/469	15	1333	91	1000
20DMWE_4824S1.5	48	36-75	80	4/15	458/469	24	833	91	500

Temperature derating curve

20DMWE_12xxS1.5

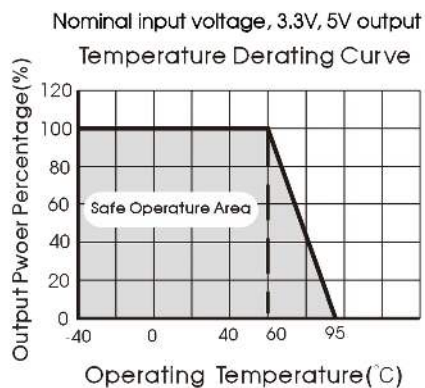

20DMWE_12xxS1.5

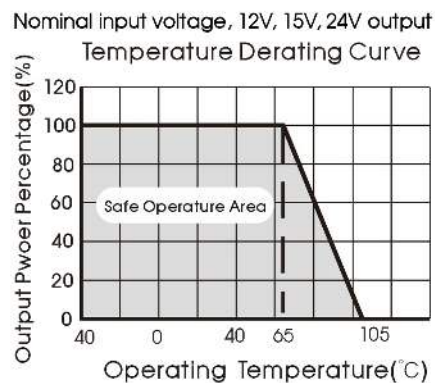

20DMWE_24xxS1.5 20DMWE_48xxS1.5

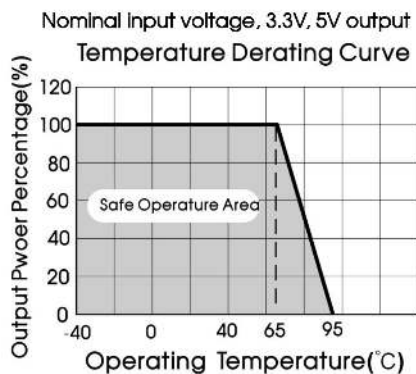

20DMWE_24xxS1.5 20DMWE_48xxS1.5

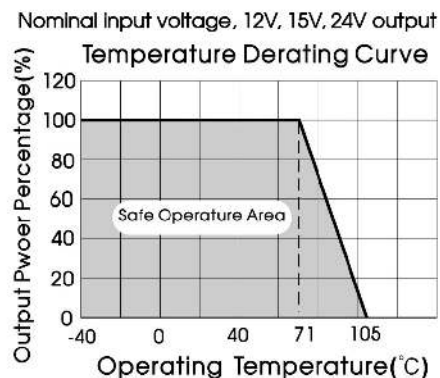

20DMWE_1.5 Series

20W - Single Output - Ultra Wide Input - Isolated & Regulated DC-DC Converter

Mechanical dimensions

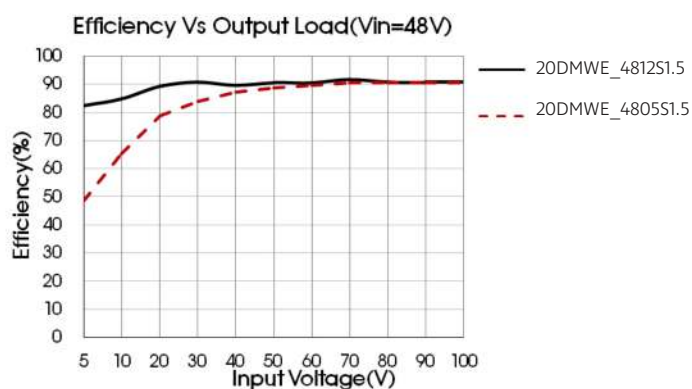
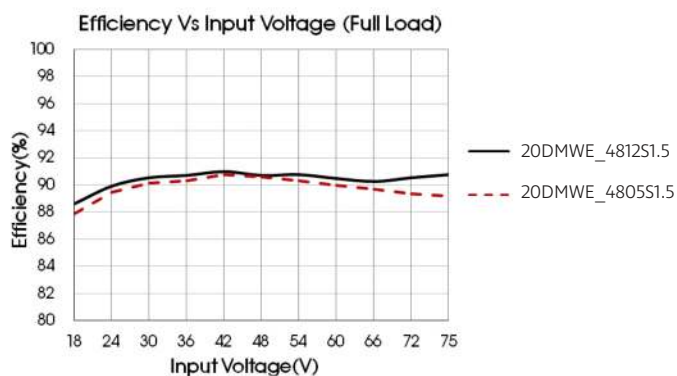
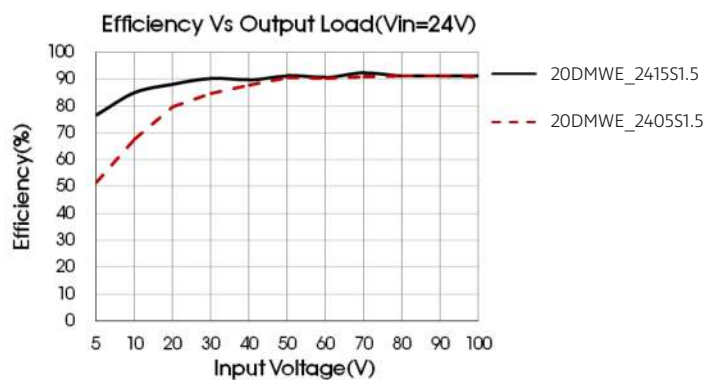
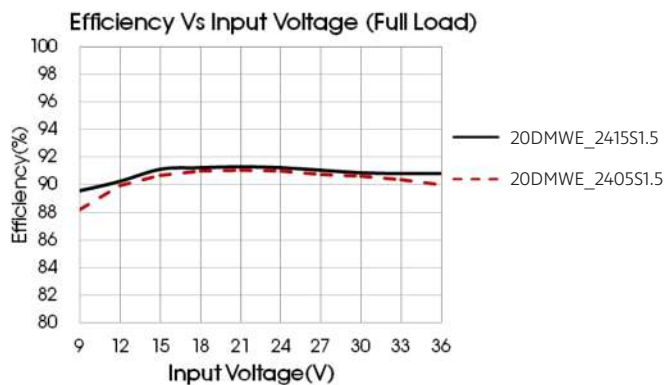

Typical application



Vout (VDC)	Cin (μF)	Cout (μF)
3.3/5/12/15	100	100
24		47

EMC solution-recommended circuit

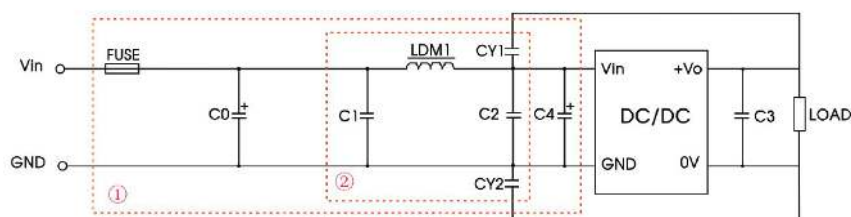

Model	Vin: 12V, 24V	Vin: 48V
FUSE	Choose according to actual input current	
C0, C4	330μF/50V	330μF/100V
C1, C2	4.7μF/50V	4.7μF/100V
C2	Refer to the Cout in Typical application	
LDM1	2.2μH	
CY1/CY2	1nF/2KV	

Part ① in the is used for EMC test and part ② for EMI filtering; selected based on needs.

20DMWE_1.5 Series

20W - Single Output - Ultra Wide Input - Isolated & Regulated DC-DC Converter

Application of trim and calculation of trim resistance

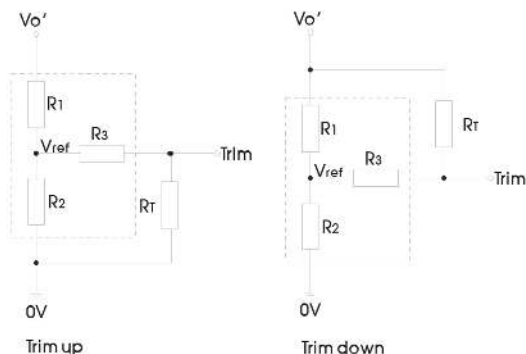

Applied circuits of Trim (Part in broken line is the interior of models)

Calculation formula of Trim resistance:

$$\begin{aligned} \text{up: } R_T &= \frac{\alpha R_2}{R_2 - \alpha} - R_3 & \alpha &= \frac{V_{ref}}{V_{o'} - V_{ref}} \cdot R_1 \\ \text{down: } R_T &= \frac{\alpha R_1}{R_1 - \alpha} - R_3 & \alpha &= \frac{V_{o'} - V_{ref}}{V_{ref}} \cdot R_2 \end{aligned}$$

R_T is Trim resistance
 α is a self-defined parameter, with no real meaning.

Vout(V)	R1(K Ω)	R2(K Ω)	R3(K Ω)	Vref(V)
3.3	4.829	2.87	15	1.24
5	2.894	2.87	10	2.5
12	11.000	2.87	17.4	2.5
15	14.494	2.87	17.4	2.5
24	24.872	2.87	20	2.5

It is not allowed to connect modules output in parallel to enlarge the power.

Mechanical dimensions

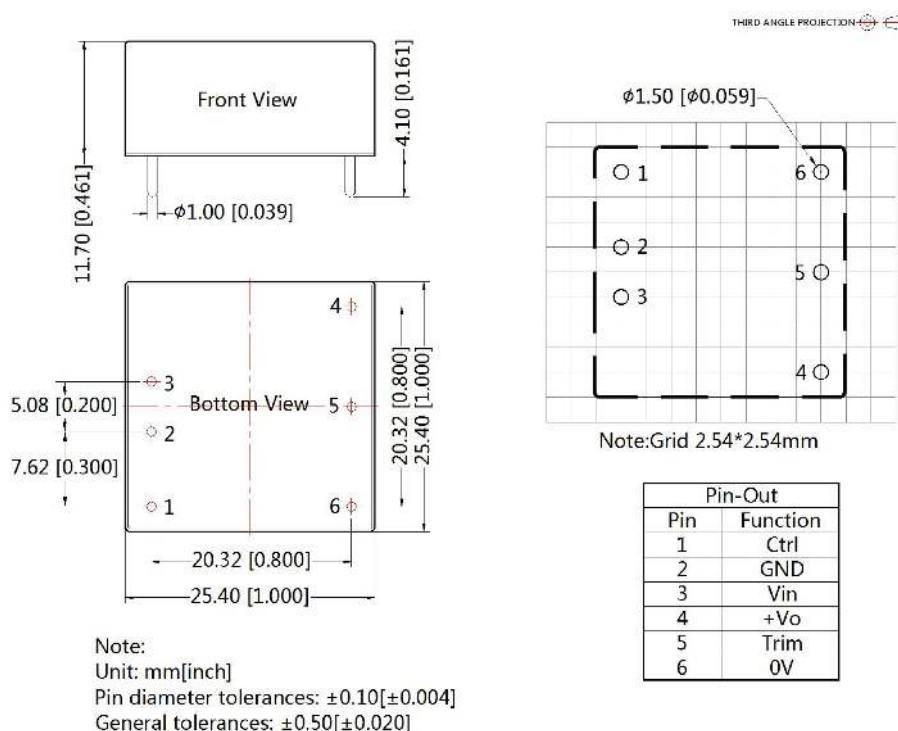

20DMWE_1.5 Series

20W - Single Output - Ultra Wide Input - Isolated & Regulated DC-DC Converter

Chassis mounting

THIRD ANGLE PROJECTION 

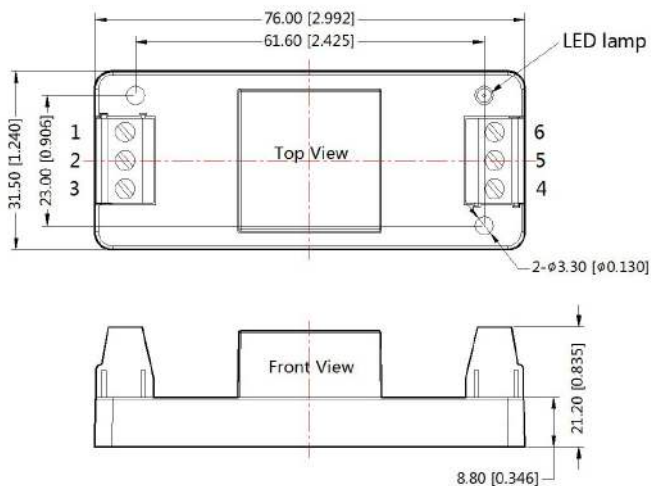

Pin-Out						
Pin	1	2	3	4	5	6
Function	Ctrl	GND	V _{in}	+V _o	Trim	0V

Note:
 Unit: mm[inch]
 Wire range: 24-12 AWG
 Tightening torque: Max 0.4 N·m
 General tolerances: ±1.00[±0.039]

Rail mounting

THIRD ANGLE PROJECTION 

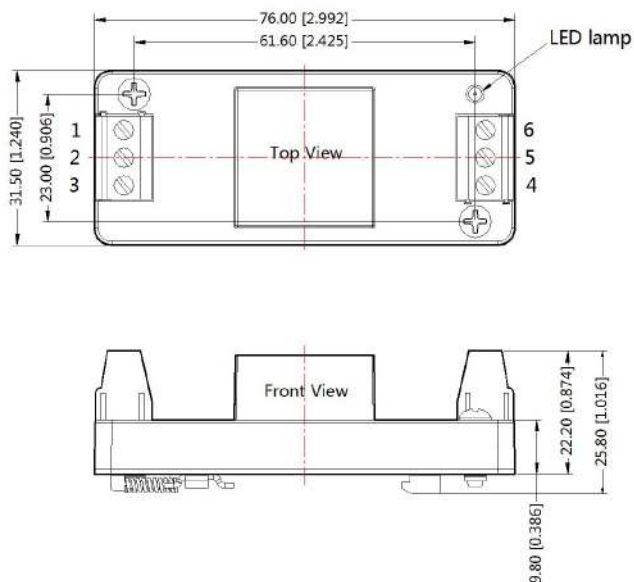

Pin-Out						
Pin	1	2	3	4	5	6
Function	Ctrl	GND	V _{in}	+V _o	Trim	0V

Note:
 Unit: mm[inch]
 Wire range: 24-12 AWG
 Tightening torque: Max 0.4 N·m
 Mounting rail: TS35
 General tolerances: ±1.00[±0.039]