

ISL9241

Buck-Boost Configurable Battery Charger with SMBus Interface and USB Power Delivery

R16DO0010EU0500
Rev.5.0
Aug 12, 2021

The [ISL9241](#) is a digitally configurable buck-boost battery charger that can support both Narrow Voltage Direct Charging (NVDC) and Hybrid Power Buck Boost (HPBB/Bypass) charging and switch between the modes using firmware control. Bypass mode is also supported using the firmware of the controller, which allows the adapter to provide power directly to the system. The ISL9241 provides charging functionality, system bus regulation, and protection features using only NFETs for tablet, Ultrabook, and notebook platforms. The advanced Renesas R3™ technology provides a high, light-load efficient Charging mode. The ISL9241 takes input power from a wide range of DC power sources (such as conventional AC/DC charger adapters, USB Type-C Power ports, and travel adapters) and safely charges battery packs with up to 4-series cell Li-ion batteries.

The system power can be provided from the adapter, battery, or a combination of both. The reconfigurable internal registers of the charger allow the use of a smaller inductor for the HPBB mode to achieve higher efficiencies across multiple power levels. The ISL9241 can operate with only a battery, only an adapter, or both connected. For Intel IMVP compliant systems, the ISL9241 includes System Power monitor (PSYS) functionality, which provides an analog signal representing total platform power. The PSYS output connects to a wide range of IMVP core regulators to provide an IMVP compliant power domain function. The ISL9241 supports reverse buck, boost, or buck-boost operation to the adapter port (OTG mode) from 2- to 4-cell batteries. This allows configurations to support USB-C Power Delivery (PD) output for Programmable Power Supply (PPS) ports. The ISL9241 serial communication uses SMBus/I²C, which allows programming of many key parameters to deliver a customized solution.

Features

- Buck-boost NVDC or hybrid power (turbo boost) charger for 2-, 3-, or 4-cell Li-ion batteries using all NFET transistors
- Input voltage range: 3.9V to 23.4V (no dead zone)
- System/battery output voltage: 3.9V to 18.304V
- Bypass mode supported to connect system to adapter
- Autonomous charging option (automatic end of charging)
- Adapter current and battery current monitor (AMON/BMON)
- PROCHOT# open-drain output, IMVP compliant
- System power monitor PSYS output, IMVP8/9 compliant
- Internal 8-bit ADC for monitoring key parameters
- USB-C PD Fast Role Swap support and PPS support
- Independent compensation pins for forward and reverse operation (OTG) modes
- Supports supplemental power (Intel V_{MIN} active protection)
- Battery Ship mode: IC ultra-low power state
- Supports JEITA compliance using an NTC
- 4x4 32 Ld TQFN package

Applications

- 2- to 4-cell tablets, notebooks, power banks, and any USB-C interface portable device requiring batteries

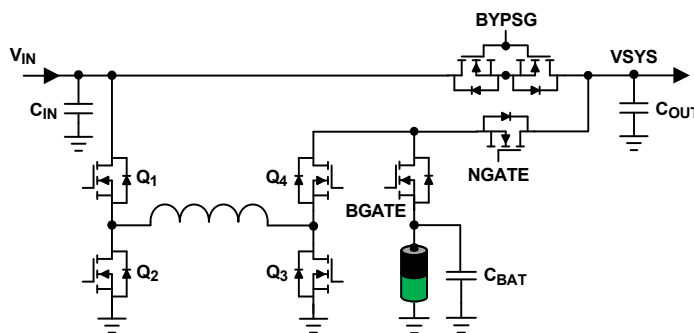

Figure 1. Typical Application

IMPORTANT NOTICE AND DISCLAIMER

RENESAS ELECTRONICS CORPORATION AND ITS SUBSIDIARIES (“RENESAS”) PROVIDES TECHNICAL SPECIFICATIONS AND RELIABILITY DATA (INCLUDING DATASHEETS), DESIGN RESOURCES (INCLUDING REFERENCE DESIGNS), APPLICATION OR OTHER DESIGN ADVICE, WEB TOOLS, SAFETY INFORMATION, AND OTHER RESOURCES “AS IS” AND WITH ALL FAULTS, AND DISCLAIMS ALL WARRANTIES, EXPRESS OR IMPLIED, INCLUDING, WITHOUT LIMITATION, ANY IMPLIED WARRANTIES OF MERCHANTABILITY, FITNESS FOR A PARTICULAR PURPOSE, OR NON-INFRINGEMENT OF THIRD PARTY INTELLECTUAL PROPERTY RIGHTS.

These resources are intended for developers skilled in the art designing with Renesas products. You are solely responsible for (1) selecting the appropriate products for your application, (2) designing, validating, and testing your application, and (3) ensuring your application meets applicable standards, and any other safety, security, or other requirements. These resources are subject to change without notice. Renesas grants you permission to use these resources only for development of an application that uses Renesas products. Other reproduction or use of these resources is strictly prohibited. No license is granted to any other Renesas intellectual property or to any third party intellectual property. Renesas disclaims responsibility for, and you will fully indemnify Renesas and its representatives against, any claims, damages, costs, losses, or liabilities arising out of your use of these resources. Renesas' products are provided only subject to Renesas' Terms and Conditions of Sale or other applicable terms agreed to in writing. No use of any Renesas resources expands or otherwise alters any applicable warranties or warranty disclaimers for these products.

(Disclaimer Rev.1.0 Mar 2020)

Corporate Headquarters

TOYOSU FORESIA, 3-2-24 Toyosu,
Koto-ku, Tokyo 135-0061, Japan
www.renesas.com

Contact Information

For further information on a product, technology, the most up-to-date version of a document, or your nearest sales office, please visit:
www.renesas.com/contact/

Trademarks

Renesas and the Renesas logo are trademarks of Renesas Electronics Corporation. All trademarks and registered trademarks are the property of their respective owners.