



FOD3181

0.5A Output Current, High Speed MOSFET Gate Driver Optocoupler

Features

- Guaranteed operating temperature range of -20°C to +85°C
- 0.5A minimum peak output current
- High speed response: 500ns max propagation delay over temperature range
- Wide V_{CC} operating range: 10V to 20V
- 5000Vrms, 1 minute isolation
- Minimum creepage distance of 7.0mm
- Minimum clearance distance of 7.0mm
- C-UL, UL and VDE* approved
- 10kV/μs minimum common mode rejection (CMR) at V_{CM} = 1,500V
- R_{DS(ON)} of 1.5Ω (typ.) offers lower power dissipation

Description

The FOD3181 is a 0.5A Output Current, High Speed MOSFET Gate Drive Optocoupler. It consists of a gallium aluminum arsenide (AlGaAs) light emitting diode optically coupled to a CMOS integrated circuit with a power stage. The power stage consists of a PMOS pull-up and a NMOS pull-down power transistor. It is ideally suited for high frequency driving of MOSFETs used in Plasma Display Panels (PDPs), motor control invertor applications, and high performance DC/DC converters.

The device is packaged in an 8-pin dual in-line housing compatible with 260°C reflow processes for lead free solder compliance.

Applications

- Plasma Display Panel
- High performance DC/DC convertor
- High performance switch mode power supply
- High performance uninterruptible power supply
- Isolated Power MOSFET gate drive

*Requires 'V' ordering option

Functional Block Diagram

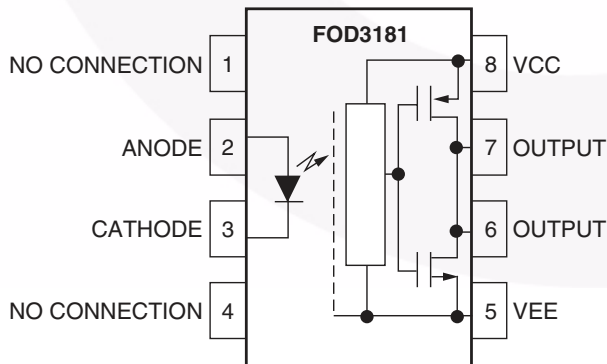

Note:

A 0.1μF bypass capacitor must be connected between pins 5 and 8.

Package Outlines

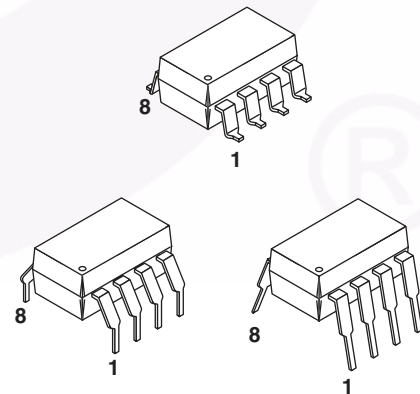

Absolute Maximum Ratings

Stresses exceeding the absolute maximum ratings may damage the device. The device may not function or be operable above the recommended operating conditions and stressing the parts to these levels is not recommended. In addition, extended exposure to stresses above the recommended operating conditions may affect device reliability. The absolute maximum ratings are stress ratings only.

Symbol	Parameter	Value	Units
T_{STG}	Storage Temperature	-40 to +125	°C
T_{OPR}	Operating Temperature	-20 to +85	°C
T_J	Junction Temperature	-20 to +125	°C
T_{SOL}	Lead Solder Temperature	260 for 10 sec.	°C
$I_{F(AVG)}$	Average Input Current ⁽¹⁾	25	mA
$I_{F(tr)}$	Minimum Rate of Rise of LED Current	250	ns
$I_{F(TRAN)}$	Peak Transient Input Current (<1 μ s pulse width, 300pps)	1.0	A
V_R	Reverse Input Voltage	5	V
$I_{OH(PEAK)}$	“High” Peak Output Current ⁽²⁾	1.5	A
$I_{OL(PEAK)}$	“Low” Peak Output Current ⁽²⁾	1.5	A
$V_{CC} - V_{EE}$	Supply Voltage	-0.5 to 25	V
$V_{O(PEAK)}$	Output Voltage	0 to V_{CC}	V
P_O	Output Power Dissipation ⁽⁴⁾	250	mW
P_D	Total Power Dissipation ⁽⁴⁾	300	mW

Recommended Operating Conditions

The Recommended Operating Conditions table defines the conditions for actual device operation. Recommended operating conditions are specified to ensure optimal performance to the datasheet specifications. Fairchild does not recommend exceeding them or designing to absolute maximum ratings.

Symbol	Parameter	Value	Units
$V_{CC} - V_{EE}$	Power Supply	10 to 20	V
$I_{F(ON)}$	Input Current (ON)	12 to 18	mA
$V_{F(OFF)}$	Input Voltage (OFF)	0 to 0.8	V
T_{OPR}	Operating Temperature	-20 to +85	°C

Electrical-Optical Characteristics (DC) ($T_A = -20^\circ\text{C}$ to $+70^\circ\text{C}$)

Over recommended operating conditions unless otherwise specified.

Symbol	Parameter	Test Conditions	Min.	Typ.*	Max.	Unit
I_{OH}	High Level Output Current ⁽²⁾⁽³⁾	$V_{OH} = (V_{CC} - V_{EE} - 1V)$	0.5			A
I_{OL}	Low Level Output Current ⁽²⁾⁽³⁾	$V_{OL} = (V_{CC} - V_{EE} - 1V)$	0.5			A
V_{OH}	High Level Output Voltage ⁽⁵⁾⁽⁶⁾	$I_O = -100\text{mA}$	$V_{CC} - 0.5$			V
V_{OL}	Low Level Output Voltage ⁽⁵⁾⁽⁶⁾	$I_O = 100\text{mA}$			$V_{EE} + 0.5$	V
I_{CCH}	High Level Supply Current	Output Open $I_F = 7$ to 10mA		4.8	6.0	mA
I_{CCL}	Low Level Supply Current	Output Open $V_F = 0$ to $0.8V$		5.0	6.0	mA
I_{FLH}	Threshold Input Current Low to High	$I_O = 0\text{mA}$, $V_O > 5V$			10	mA
V_{FHL}	Threshold Input Voltage High to Low	$I_O = 0\text{mA}$, $V_O < 0.5V$	0.8			V
V_F	Input Forward Voltage	$I_F = 10\text{mA}$	1.2	1.5	1.8	V
$\Delta V_F / T_A$	Temperature Coefficient of Forward Voltage	$I_F = 10\text{mA}$		-1.5		mV/ $^\circ\text{C}$
BV_R	Input Reverse Breakdown Voltage	$I_R = 10\mu\text{A}$	5			V
C_{IN}	Input Capacitance	$f = 1\text{MHz}$, $V_F = 0V$		60		pF

Switching Characteristics ($T_A = -20^\circ\text{C}$ to $+70^\circ\text{C}$)

Over recommended operating conditions unless otherwise specified.

Symbol	Parameter	Test Conditions	Min.	Typ.*	Max.	Unit
t_{PLH}	Propagation Delay Time to High Output Level ⁽⁷⁾	$I_F = 10\text{mA}$, $R_g = 10\Omega$, $f = 250\text{kHz}$, Duty Cycle = 50%, $C_g = 10\text{nF}$	50	135	500	ns
t_{PHL}	Propagation Delay Time to Low Output Level ⁽⁷⁾		50	105	500	ns
t_r	Rise Time	$C_L = 10\text{nF}$, $R_g = 10\Omega$		75		ns
t_f	Fall Time			55		ns
$ CM_H $	Output High Level Common Mode Transient Immunity ⁽⁸⁾⁽⁹⁾	$T_A = +25^\circ\text{C}$, $I_f = 7$ to 10mA , $V_{CM} = 1.5\text{kV}$, $V_{CC} = 20V$	10			kV/ μs
$ CM_L $	Output Low Level Common Mode Transient Immunity ⁽⁸⁾⁽¹⁰⁾	$T_A = +25^\circ\text{C}$, $V_f = 0V$, $V_{CM} = 1.5\text{kV}$, $V_{CC} = 20V$	10			kV/ μs

Isolation Characteristics ($T_A = -20^\circ\text{C}$ to $+70^\circ\text{C}$)

Symbol	Parameter	Test Conditions	Min.	Typ.*	Max.	Unit
V_{ISO}	Withstand Isolation Voltage ⁽¹¹⁾⁽¹²⁾	$T_A = 25^\circ\text{C}$, R.H. < 50%, $t = 1\text{min.}$, $I_{I-O} \leq 20\mu\text{A}$	5000			V_{rms}
R_{I-O}	Resistance (input to output) ⁽¹²⁾	$V_{I-O} = 500V$		10^{11}		Ω
C_{I-O}	Capacitance (input to output)	Freq. = 1MHz		1		pF

* All typical values at $T_A = 25^\circ\text{C}$

Notes:

1. Derate linearly above +70°C free air temperature at a rate of 0.3mA/°C.
2. The output currents I_{OH} and I_{OL} are specified with a capacitive current limited load = $(3 \times 0.01\mu\text{F}) + 0.5\Omega$, frequency = 8kHz, 50% DF.
3. The output currents I_{OH} and I_{OL} are specified with a capacitive current limited load = $(3 \times 0.01\mu\text{F}) + 40\Omega$, frequency = 8kHz, 50% DF.
4. No derating required across operating temperature range.
5. In this test, V_{OH} is measured with a dc load current of 100mA. When driving capacitive load V_{OH} will approach V_{CC} as I_{OH} approaches zero amps.
6. Maximum pulse width = 1ms, maximum duty cycle = 20%.
7. t_{PHL} propagation delay is measured from the 50% level on the falling edge of the input pulse to the 50% level of the falling edge of the V_O signal. t_{PLH} propagation delay is measured from the 50% level on the rising edge of the input pulse to the 50% level of the rising edge of the V_O signal.
8. Pin 1 and 4 need to be connected to LED common.
9. Common mode transient immunity in the high state is the maximum tolerable dV_{CM}/dt of the common mode pulse V_{CM} to assure that the output will remain in the high state (i.e. $V_O > 10.0V$).
10. Common mode transient immunity in a low state is the maximum tolerable dV_{CM}/dt of the common mode pulse, V_{CM} , to assure that the output will remain in a low state (i.e. $V_O < 1.0V$).
11. In accordance with UL 1577, each optocoupler is proof tested by applying an insulation test voltage > 6000Vrms, 60Hz for 1 second (leakage detection current limit $I_{L-O} < 5\mu\text{A}$).
12. Device considered a two-terminal device: pins on input side shorted together and pins on output side shorted together.

Typical Performance Curves

Fig. 1 Input Forward Current vs. Forward Voltage

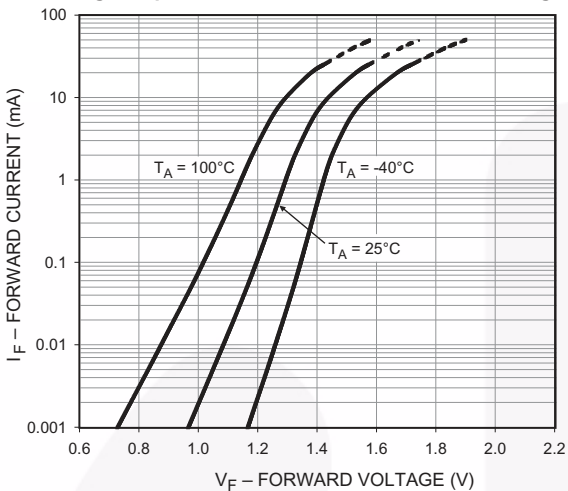

Fig. 2 Low To High Input Current Threshold vs. Ambient Temperature

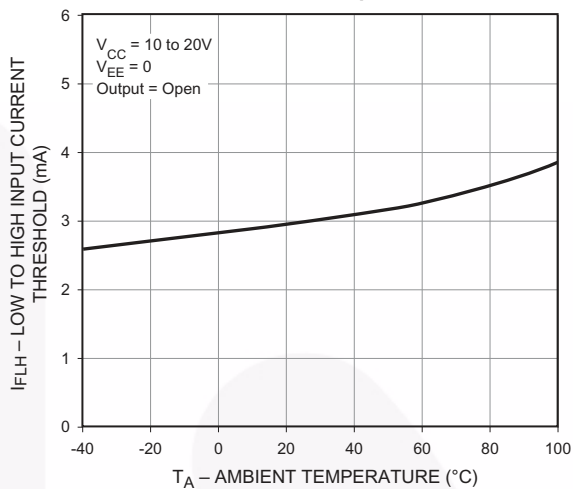

Fig. 3 Output Low Voltage vs. Ambient Temperature

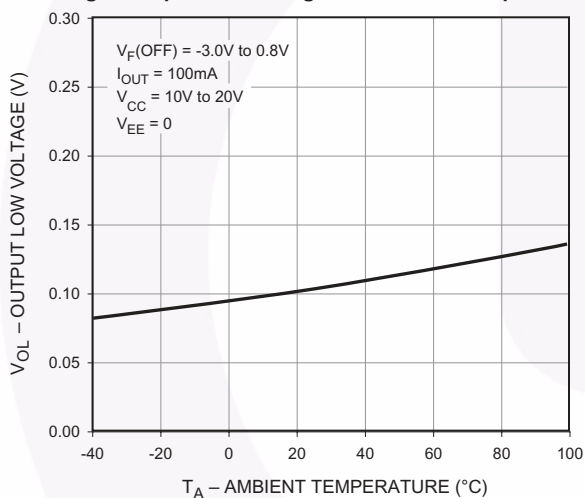

Fig. 4 High Output Voltage Drop vs. Ambient Temperature

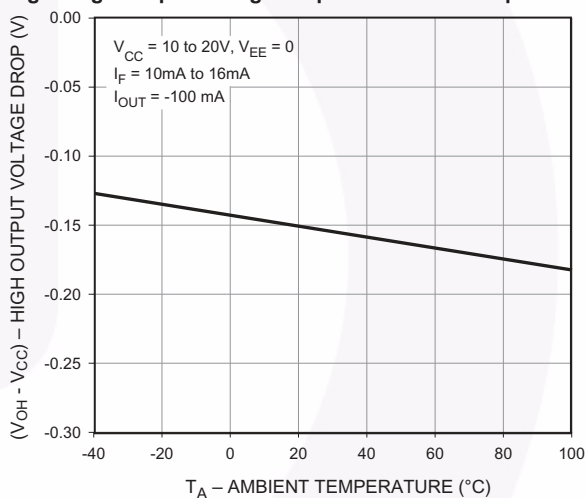

Fig. 5 Supply Current vs. Ambient Temperature

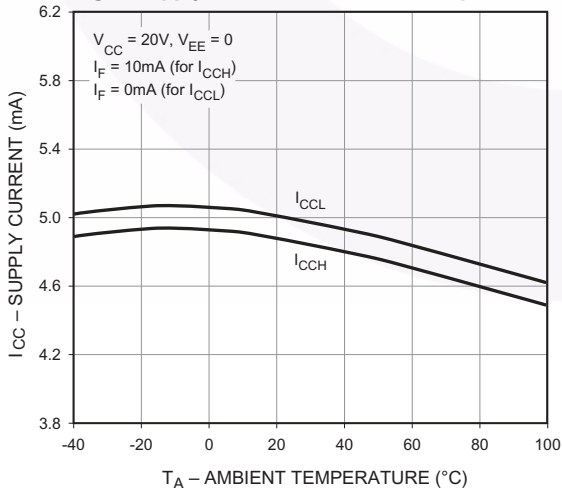
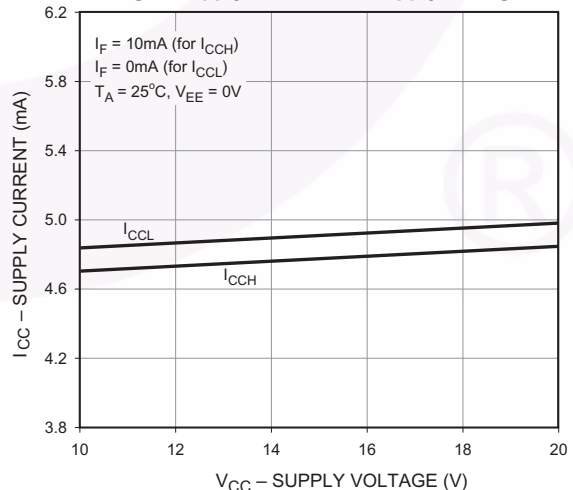

Fig. 6 Supply Current vs. Supply Voltage



Typical Performance Curves (Continued)

Fig. 7 Propagation Delay vs. Load Capacitance

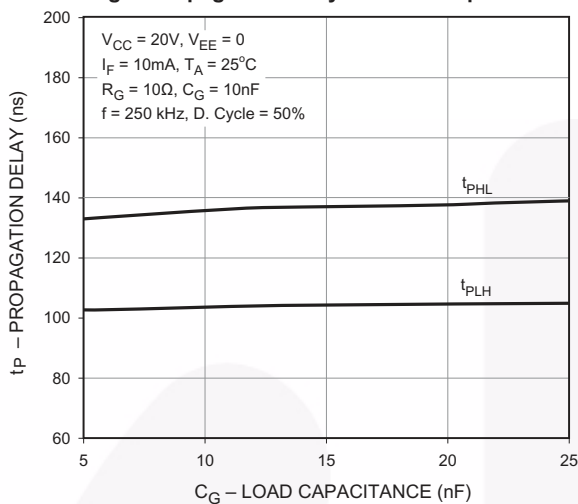

Fig. 8 Propagation Delay vs. Forward LED Current

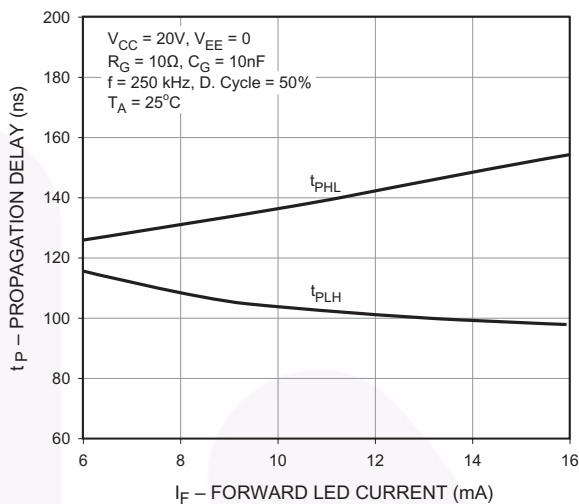

Fig. 9 Propagation Delay vs. Series Load Resistance

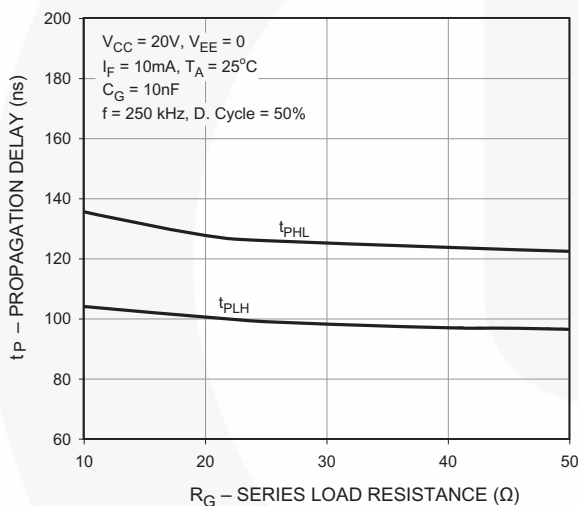

Fig. 10 Propagation Delay vs. Ambient Temperature

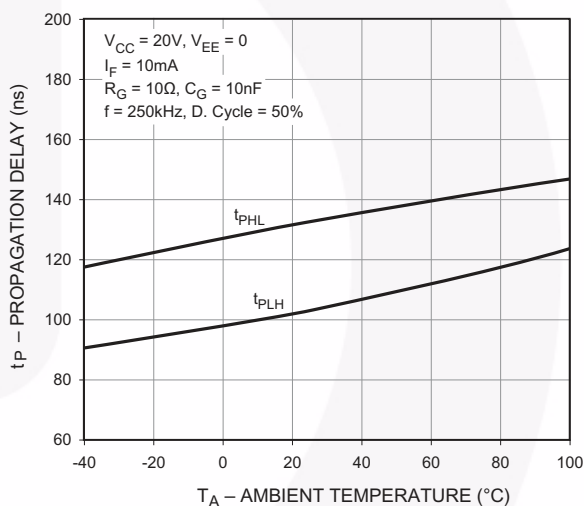
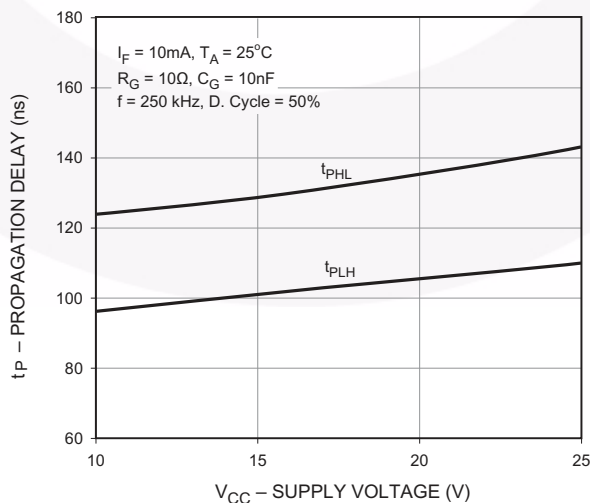
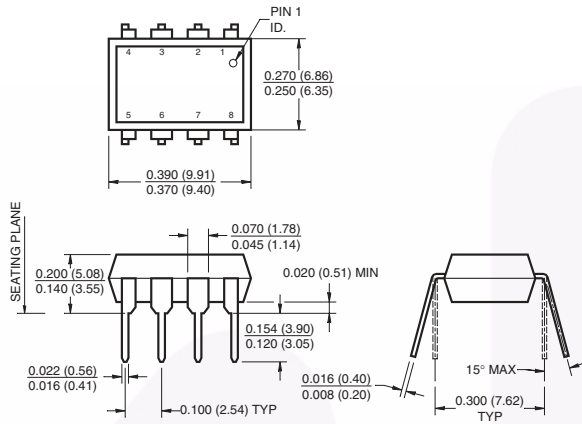

Fig. 11 Propagation Delay vs. Supply Voltage



Package Dimensions

Through Hole



0.4" Lead Spacing

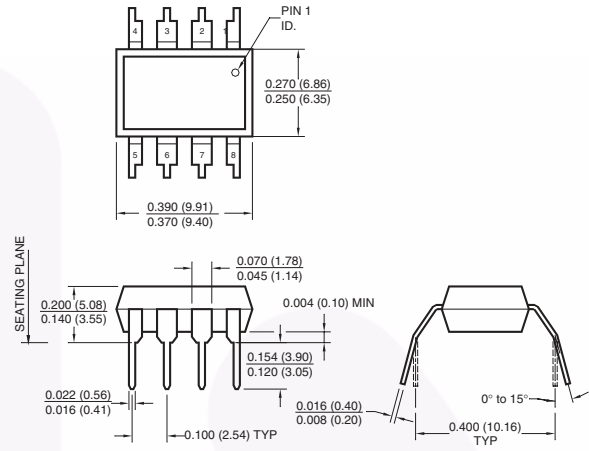

Surface Mount

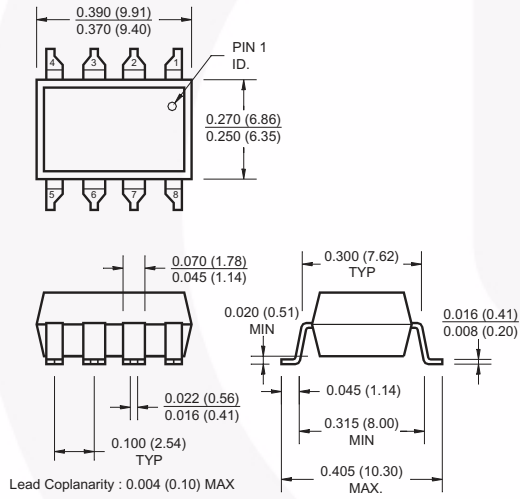

8-Pin DIP – Land Pattern

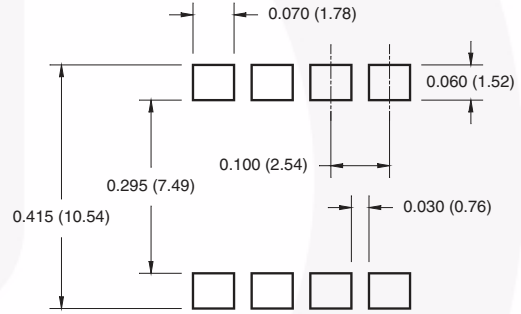

Note:

All dimensions are in inches (millimeters)

Ordering Information

Option	Order Entry Identifier (Example)	Description
No option	FOD3181	Standard Through Hole Device
S	FOD3181S	Surface Mount, Lead Bend
SD	FOD3181SD	Surface Mount, Tape and Reel
T	FOD3181T	0.4" Lead Spacing
V	FOD3181V	VDE 0884
TV	FOD3181TV	VDE 0884, 0.4" Lead Spacing
SV	FOD3181SV	VDE 0884, Surface Mount
SDV	FOD3181SDV	VDE 0884, Surface Mount, Tape and Reel

Marking Information

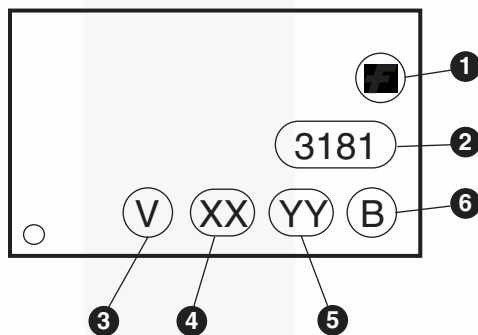

Definitions

1	Fairchild logo
2	Device number
3	VDE mark (Note: Only appears on parts ordered with VDE option – See order entry table)
4	Two digit year code, e.g., '03'
5	Two digit work week ranging from '01' to '53'
6	Assembly package code

Carrier Tape Specifications

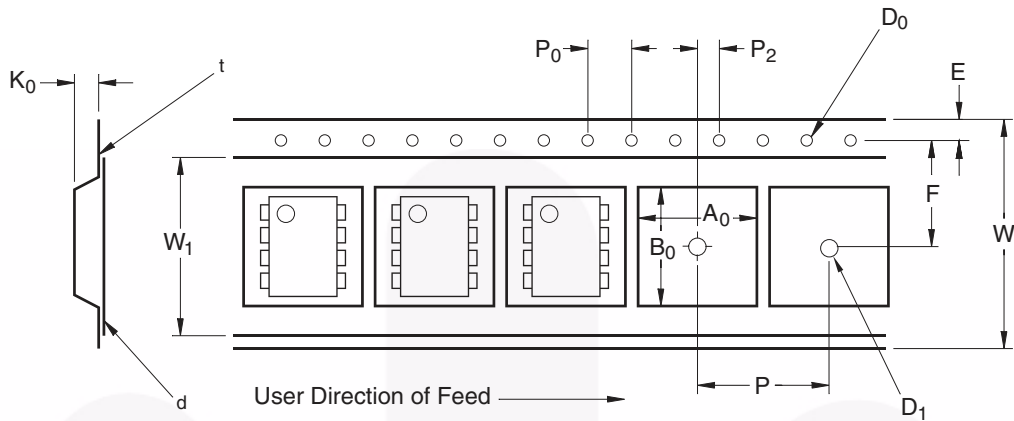

Symbol	Description	Dimension in mm
W	Tape Width	16.0 ± 0.3
t	Tape Thickness	0.30 ± 0.05
P ₀	Sprocket Hole Pitch	4.0 ± 0.1
D ₀	Sprocket Hole Diameter	1.55 ± 0.05
E	Sprocket Hole Location	1.75 ± 0.10
F	Pocket Location	7.5 ± 0.1
P ₂		4.0 ± 0.1
P	Pocket Pitch	12.0 ± 0.1
A ₀	Pocket Dimensions	10.30 ± 0.20
B ₀		10.30 ± 0.20
K ₀		4.90 ± 0.20
W ₁	Cover Tape Width	1.6 ± 0.1
d	Cover Tape Thickness	0.1 max
	Max. Component Rotation or Tilt	10°
R	Min. Bending Radius	30

Reflow Profile

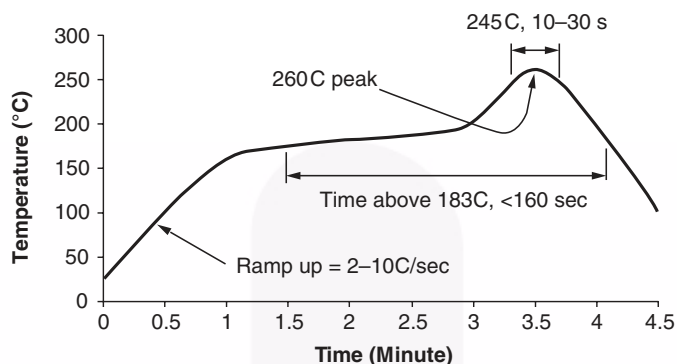

- Peak reflow temperature: 260C (package surface temperature)
- Time of temperature higher than 183C for 160 seconds or less
- One time soldering reflow is recommended

Output Power Derating

The maximum package power dissipation is 295mW. The package is limited to this level to ensure that under normal operating conditions and over extended temperature range that the semiconductor junction temperatures do not exceed 125°C. The package power is composed of three elements; the LED, static operating power of the output IC, and the power dissipated in the output power MOSFET transistors. The power rating of the output IC is 250mW. This power is divided between the static power of the integrated circuit, which is the product of I_{DD} times the power supply voltage ($V_{DD} - V_{EE}$). The maximum IC static output power is 150mW, ($V_{DD} - V_{EE}$) = 25V, I_{DD} = 6mA. This maximum condition is valid over the operational temperature range of -40°C to +100°C. Under these maximum operating conditions, the output of the power MOSFET is allowed to dissipate 100mW of power.

The absolute maximum output power dissipation versus ambient temperature is shown in Figure 12. The output driver is capable of supplying 100mW of output power over the temperature range from -40°C to 87°C. The output derates to 90mW at the absolute maximum operating temperature of 100°C.

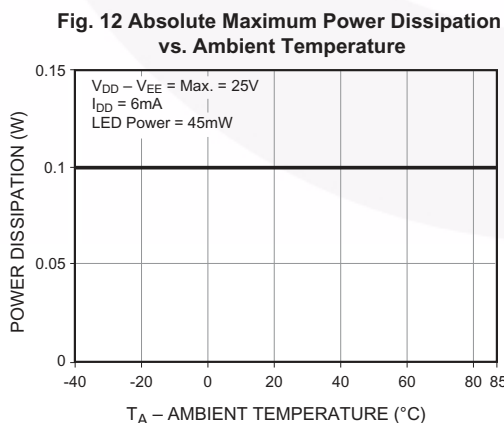

The output power is the product of the average output current squared times the output transistor's $R_{DS(ON)}$:

$$P_{O(AVG)} = I_{O(AVG)}^2 \cdot R_{DS(ON)}$$

The $I_{O(AVG)}$ is the product of the duty factor times the peak current flowing in the output. The duty factor is the ratio of the 'on' time of the output load current divided by the period of the operating frequency. An $R_{DS(ON)}$ of 2.0Ω results in an average output load current of 200mA. The load duty factor is a ratio of the average output time of the power MOSFET load circuit and period of the driving frequency.

The maximum permissible, operating frequency is determined by the load supplied to the output at its resulting output pulse width. Figure 13 shows an example of a 0.03μF gate to source capacitance with a series resistance of 40Ω. This reactive load results in a composite average pulse width of 1.5μs. Under this load condition it is not necessary to derate the absolute maximum output current out to 250kHz.

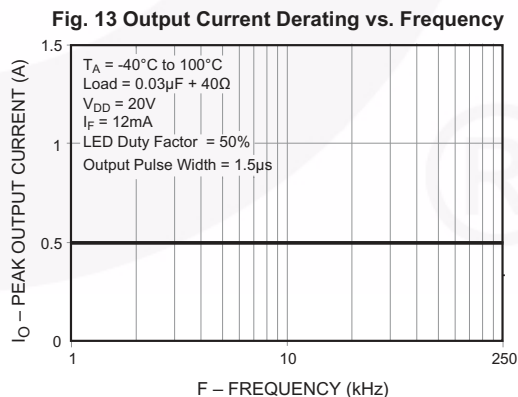

I_{OH} and I_{OL} Test Conditions

This device is tested and specified when driving a complex reactive load. The load consists of a capacitor in the series with a current limiting resistor. The capacitor represents the gate to source capacitance of a power MOSFET transistor. The test load is a $0.03\mu\text{F}$ capacitor in series with a 40Ω resistor. The LED test frequency is 10.0kHz with a 50% duty cycle. The combined I_{OH} and I_{OL} output load current duty factor is 0.6% at the test frequency.

Figure 14 illustrates the relationship of the LED input drive current and the device's output voltage and sourcing and sinking currents. The $0.03\mu\text{F}$ capacitor load represents the gate to source capacitance of a very large power MOSFET transistor. A single supply voltage of 20V is used in the evaluation.

Figure 15 shows the test schematic to evaluate the output voltage and sourcing and sinking capability of the device. The I_{OH} and I_{OL} are measured at the peak of their respective current pulses.

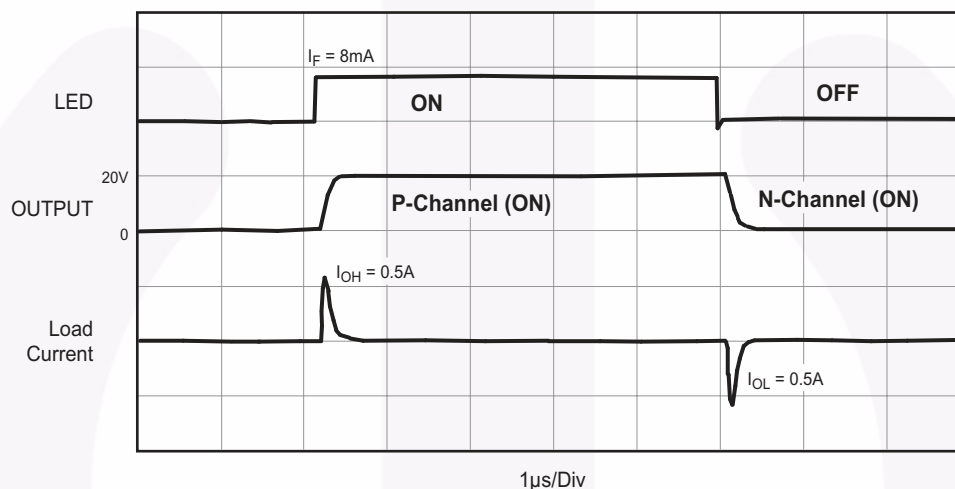

Figure 14. FOD 3180 Output Current and Output Voltage vs. LED Drive

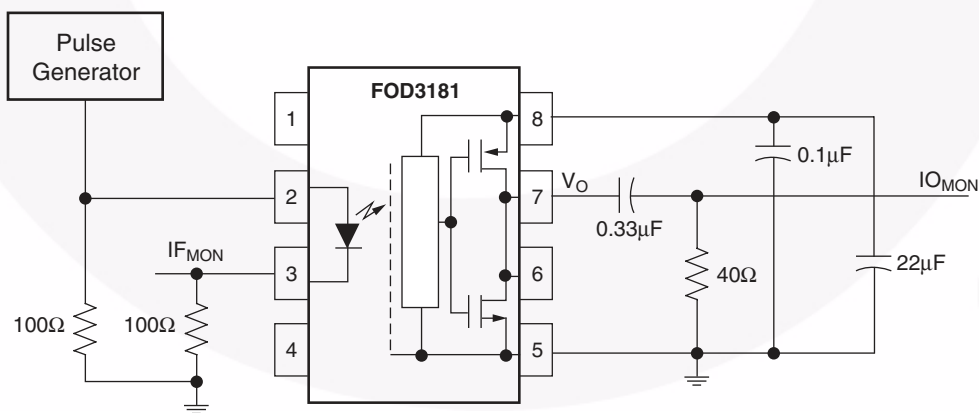

Figure 15. Test Schematic



Build it Now™
 CorePLUS™
 CorePOWER™
 CROSSVOLT™
 CTL™
 Current Transfer Logic™
 EcoSPARK®
 EfficientMax™
 EZSWITCH™ *



Fairchild®
 Fairchild Semiconductor®
 FACT Quiet Series™
 FACT®
 FAST®
 FastvCore™
 FlashWriter® *

FPS™
 F-PFS™
 FRFET®
 Global Power ResourceSM
 Green FPS™
 Green FPS™ e-Series™
 GTO™
 IntelliMAX™
 ISOPLANAR™
 MegaBuck™
 MICROCOUPLER™
 MicroFET™
 MicroPak™
 MillerDrive™
 MotionMax™
 Motion-SPM™
 OPTOLOGIC®
 OPTOPLANAR®

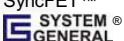
PDP SPM™
 Power-SPM™
 PowerTrench®
 Programmable Active Droop™
 QFET®
 QS™
 Quiet Series™
 RapidConfigure™
 Saving our world, 1mW at a time™
 SmartMax™
 SMART START™
 SPM®
 STEALTH™
 SuperFET™
 SuperSOT™3
 SuperSOT™6
 SuperSOT™8
 SupreMOS™
 SyncFET™

The Power Franchise®
 the
power
 franchise
 TinyBoost™
 TinyBuck™
 TinyLogic®
 TINYOPTO™
 TinyPower™
 TinyPWM™
 TinyWire™
 SerDes™

 UHC®
 Ultra FRFET™
 UniFET™
 VCX™
 VisualMax™

* EZSWITCH™ and FlashWriter® are trademarks of System General Corporation, used under license by Fairchild Semiconductor.

DISCLAIMER

FAIRCHILD SEMICONDUCTOR RESERVES THE RIGHT TO MAKE CHANGES WITHOUT FURTHER NOTICE TO ANY PRODUCTS HEREIN TO IMPROVE RELIABILITY, FUNCTION, OR DESIGN. FAIRCHILD DOES NOT ASSUME ANY LIABILITY ARISING OUT OF THE APPLICATION OR USE OF ANY PRODUCT OR CIRCUIT DESCRIBED HEREIN; NEITHER DOES IT CONVEY ANY LICENSE UNDER ITS PATENT RIGHTS, NOR THE RIGHTS OF OTHERS. THESE SPECIFICATIONS DO NOT EXPAND THE TERMS OF FAIRCHILD'S WORLDWIDE TERMS AND CONDITIONS, SPECIFICALLY THE WARRANTY THEREIN, WHICH COVERS THESE PRODUCTS.

LIFE SUPPORT POLICY

FAIRCHILD'S PRODUCTS ARE NOT AUTHORIZED FOR USE AS CRITICAL COMPONENTS IN LIFE SUPPORT DEVICES OR SYSTEMS WITHOUT THE EXPRESS WRITTEN APPROVAL OF FAIRCHILD SEMICONDUCTOR CORPORATION.

As used herein:

1. Life support devices or systems are devices or systems which, (a) are intended for surgical implant into the body or (b) support or sustain life, and (c) whose failure to perform when properly used in accordance with instructions for use provided in the labeling, can be reasonably expected to result in a significant injury of the user.
2. A critical component in any component of a life support, device, or system whose failure to perform can be reasonably expected to cause the failure of the life support device or system, or to affect its safety or effectiveness.

ANTI-COUNTERFEITING POLICY

Fairchild Semiconductor Corporation's Anti-Counterfeiting Policy. Fairchild's Anti-Counterfeiting Policy is also stated on our external website, www.fairchildsemi.com, under Sales Support.

Counterfeiting of semiconductor parts is a growing problem in the industry. All manufacturers of semiconductor products are experiencing counterfeiting of their parts. Customers who inadvertently purchase counterfeit parts experience many problems such as loss of brand reputation, substandard performance, failed applications, and increased cost of production and manufacturing delays. Fairchild is taking strong measures to protect ourselves and our customers from the proliferation of counterfeit parts. Fairchild strongly encourages customers to purchase Fairchild parts either directly from Fairchild or from Authorized Fairchild Distributors who are listed by country on our web page cited above. Products customers buy either from Fairchild directly or from Authorized Fairchild Distributors are genuine parts, have full traceability, meet Fairchild's quality standards for handling and storage and provide access to Fairchild's full range of up-to-date technical and product information. Fairchild and our Authorized Distributors will stand behind all warranties and will appropriately address any warranty issues that may arise. Fairchild will not provide any warranty coverage or other assistance for parts bought from Unauthorized Sources. Fairchild is committed to combat this global problem and encourage our customers to do their part in stopping this practice by buying direct or from authorized distributors.

PRODUCT STATUS DEFINITIONS

Definition of Terms

Datasheet Identification	Product Status	Definition
--------------------------	----------------	------------