

4

3

2

1

THIS DRAWING IS UNPUBLISHED. RELEASED FOR PUBLICATION
 © COPYRIGHT ALL RIGHTS RESERVED.

LOC	DIST	REVISIONS					
DY	-	P	LTR	DESCRIPTION	DATE	DWN	APVD
		C2		REVISED ECR-20-016788	22MAR2021	EZ	NS

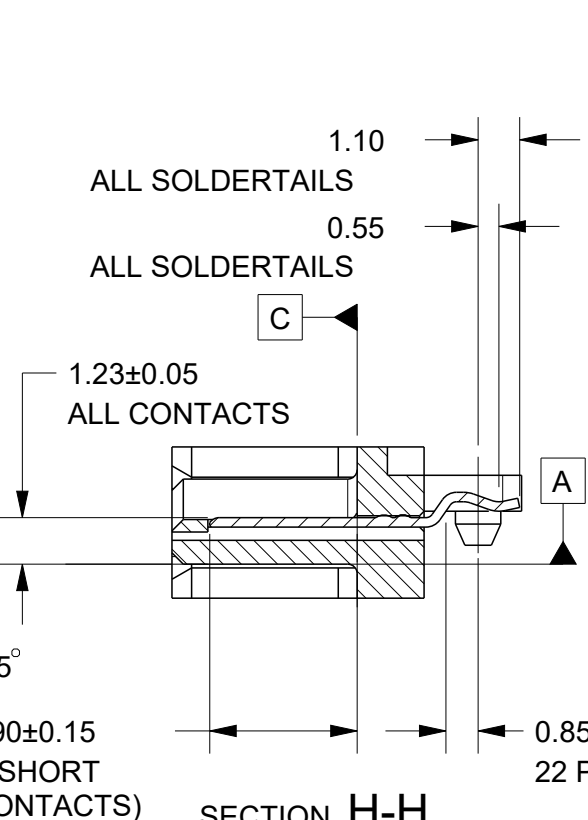
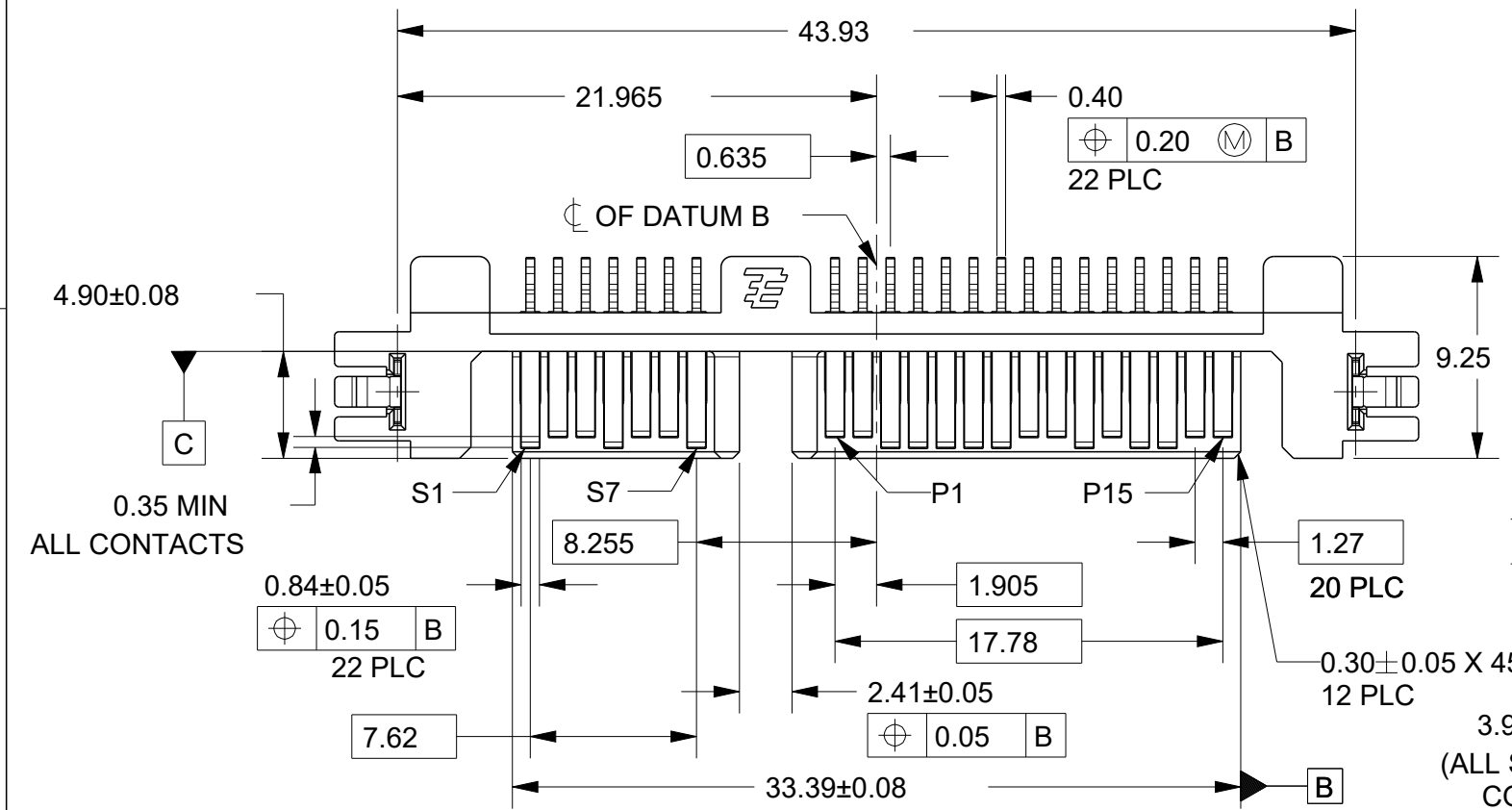

- NOTES:
- 1 MATERIAL
HOUSING: HIGH TEMPERATURE THERMOPLASTICS, GLASS FILLED, BLACK, UL94V-0, REGRIND 25% MAXIMUM
CONTACT: COPPER ALLOY
SOLDER PEG: COPPER ALLOY
 - 2 FINISH
CONTACT: "A" MIN GOLD ON MATING AREA AND 2.54µm MIN MATTE TIN (LEAD-FREE) ON SOLDER AREA
BOTH OVER 1.27µm MIN NICKEL ENTIRE
SOLDER PEG: 2.54µm MIN TIN (LEAD-FREE) OVER 1.27µm MIN NICKEL ENTIRE
 - 3 CAVITY NO LOCATED AT APPROXIMATE AREA AS SHOWN
 - 4 DATE CODE

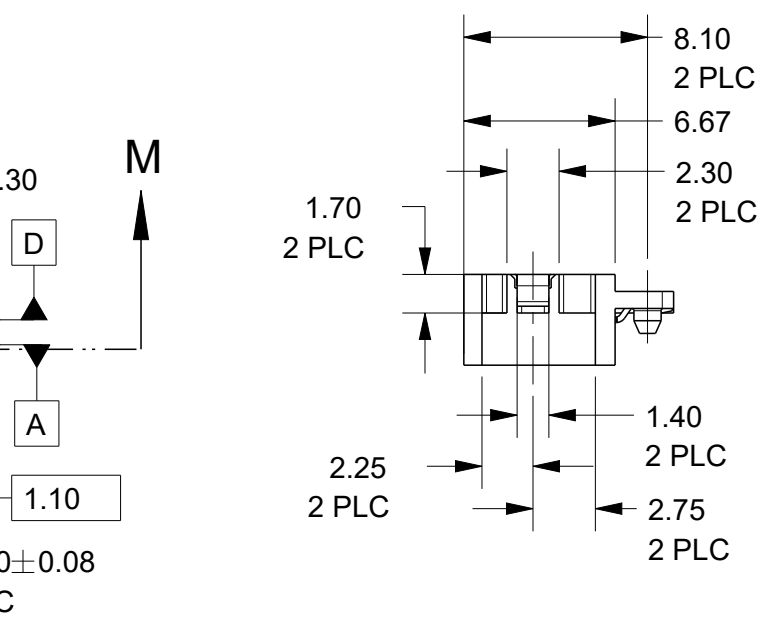
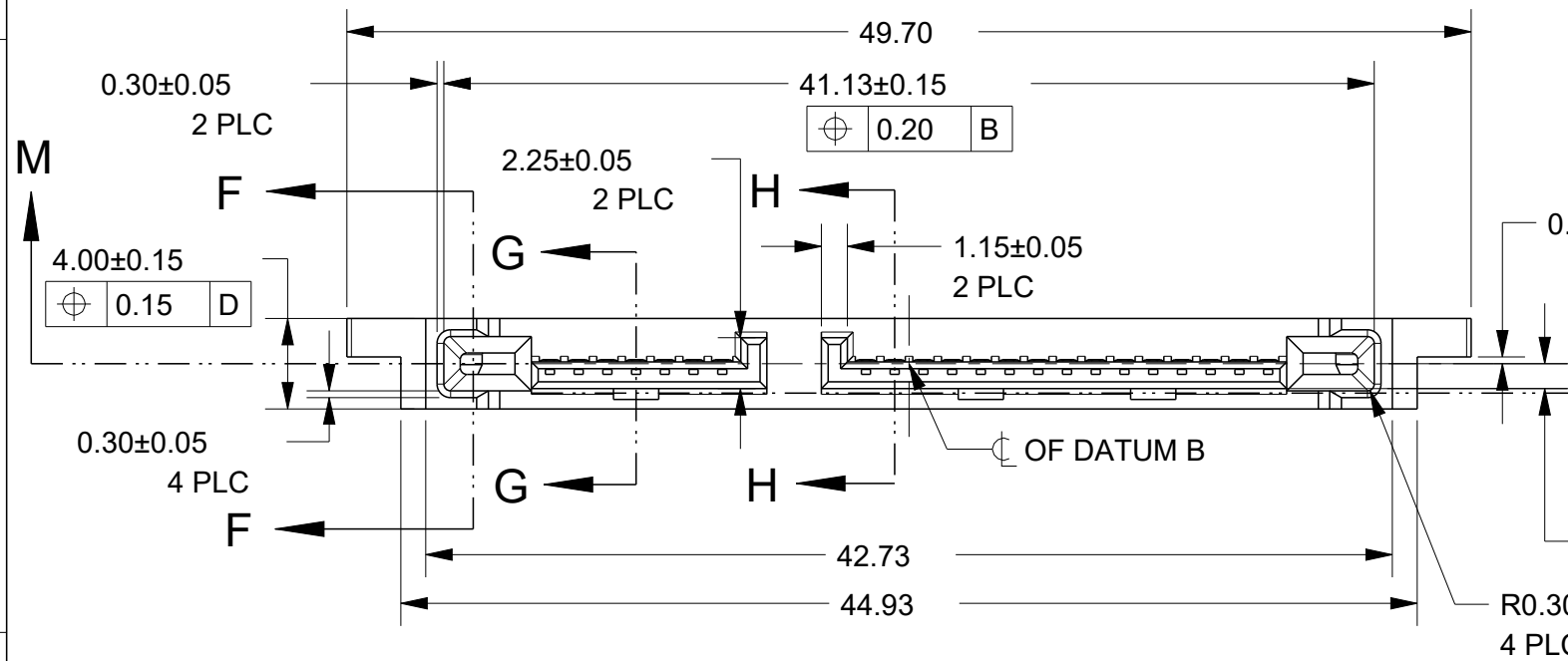
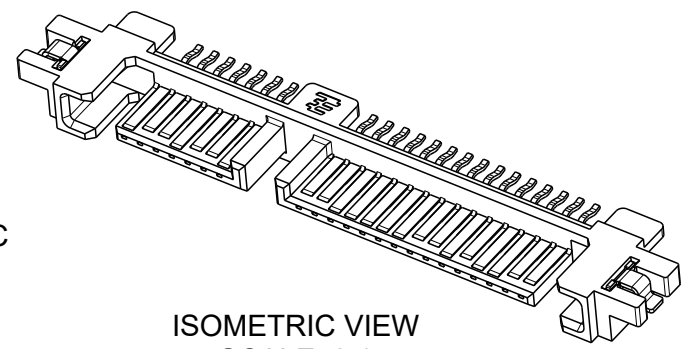

EOL	0.76µm	1735783-3
EOL	0.38µm	1735783-2
EOL	0.05µm	1735783-1
	"A"	PART NO.

P/N:1735783-1,-2,-3 AS SHOWN

THIS DRAWING IS A CONTROLLED DOCUMENT.		DWN JASON CHOW 05JAN09																
DIMENSIONS: mm		CHK AP TAY																
TOLERANCES UNLESS OTHERWISE SPECIFIED:		APVD SF LEONG	NAME SLIMLITE SATA PLUG, 15+7P, SMT															
<table border="0"> <tr><td>0 PLC</td><td>±-</td></tr> <tr><td>1 PLC</td><td>±0.20</td></tr> <tr><td>2 PLC</td><td>±0.20</td></tr> <tr><td>3 PLC</td><td>±0.20</td></tr> <tr><td>4 PLC</td><td>±-</td></tr> <tr><td>ANGLES</td><td>±2°</td></tr> </table>		0 PLC	±-	1 PLC	±0.20	2 PLC	±0.20	3 PLC	±0.20	4 PLC	±-	ANGLES	±2°	PRODUCT SPEC 108-51052	SIZE A3	CAGE CODE 00779	DRAWING NO C-1735783	RESTRICTED TO -
0 PLC	±-																	
1 PLC	±0.20																	
2 PLC	±0.20																	
3 PLC	±0.20																	
4 PLC	±-																	
ANGLES	±2°																	
MATERIAL 1		FINISH 2	WEIGHT 1.43g	SCALE 3:1	SHEET 1 OF 3	REV C2												
CUSTOMER DRAWING																		

4

3

2

1

THIS DRAWING IS UNPUBLISHED.

RELEASED FOR PUBLICATION

© COPYRIGHT

ALL RIGHTS RESERVED.

LOC	DIST	REVISIONS					
DY	-	P	LTR	DESCRIPTION	DATE	DWN	APVD
				SEE SHEET 1			

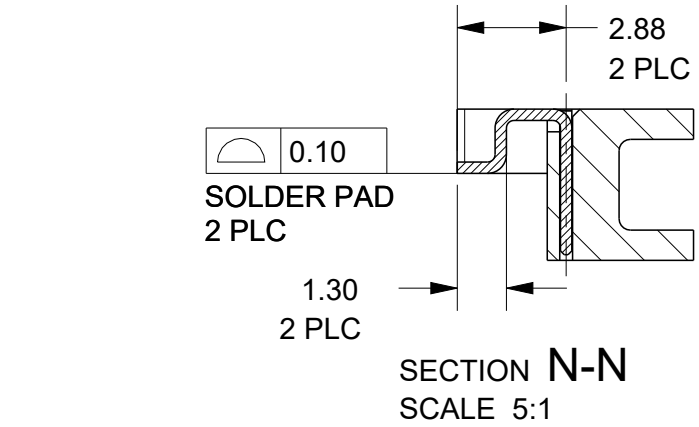
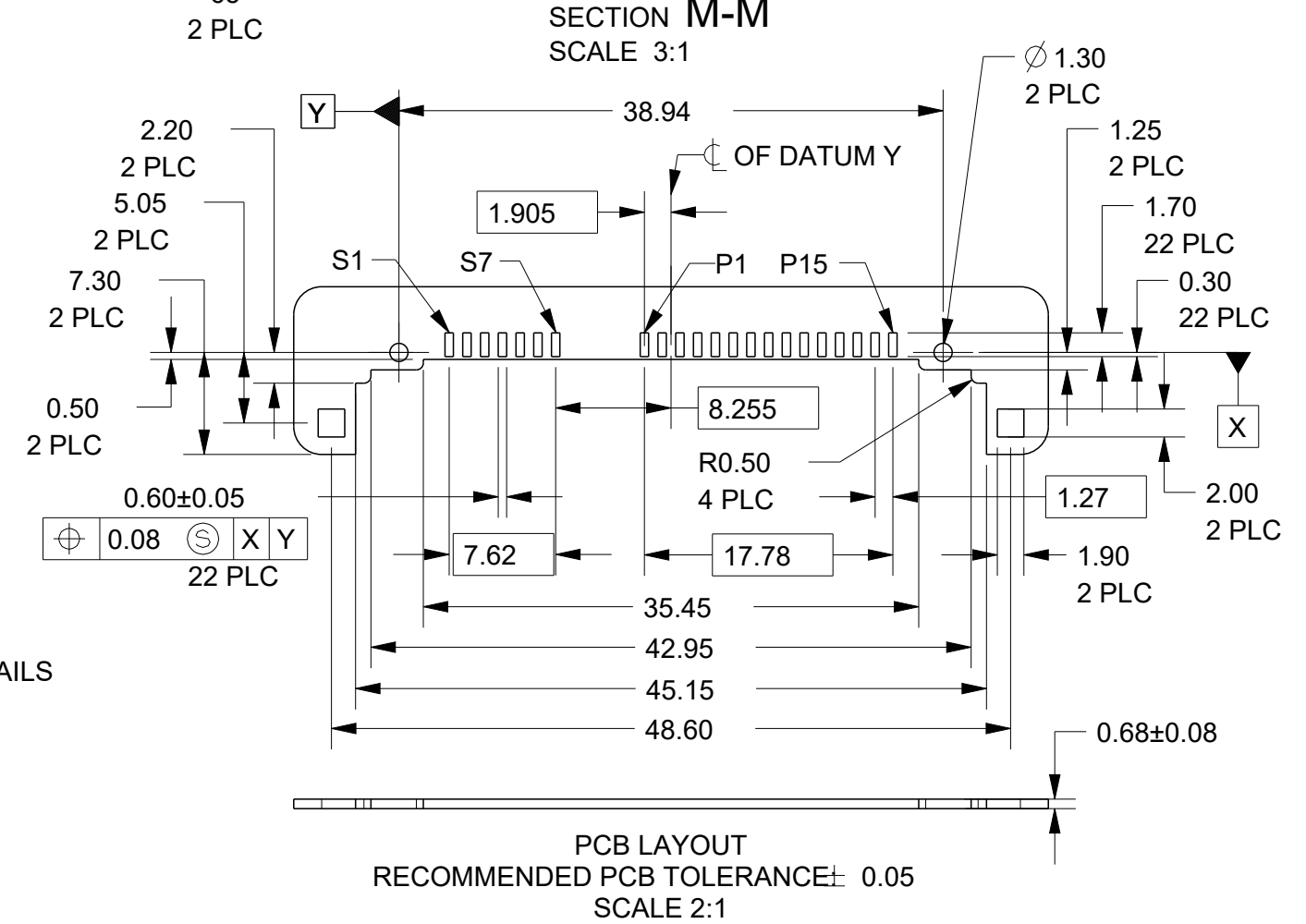
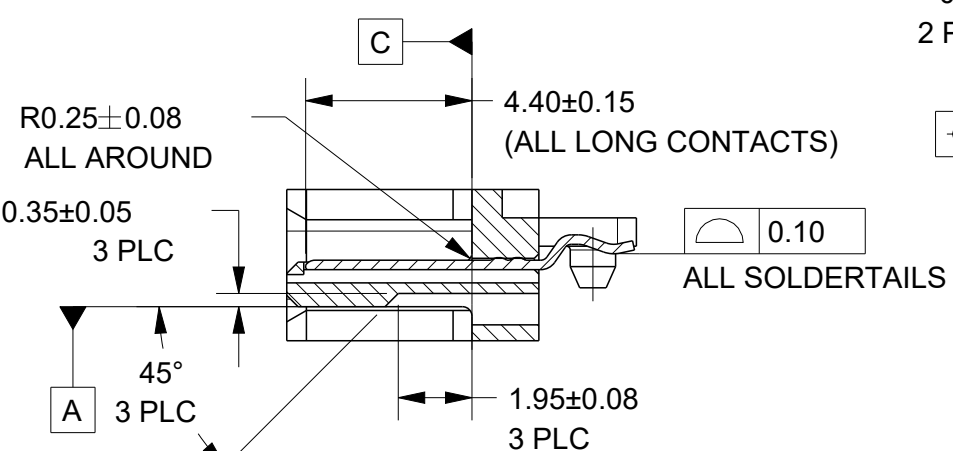
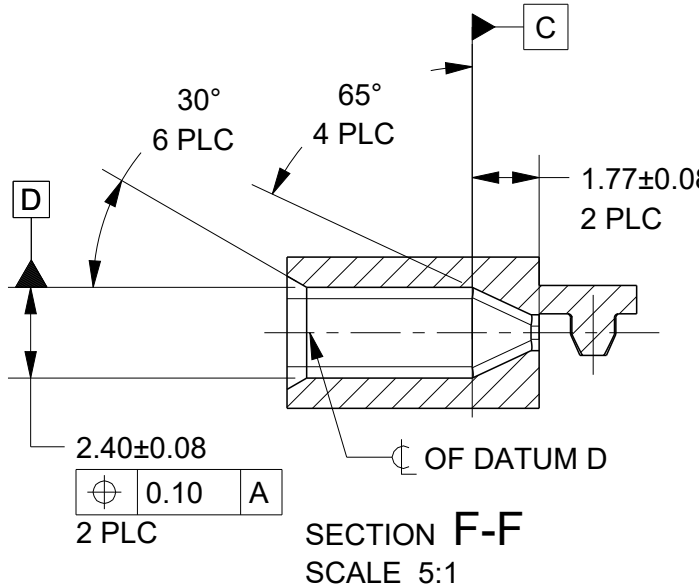
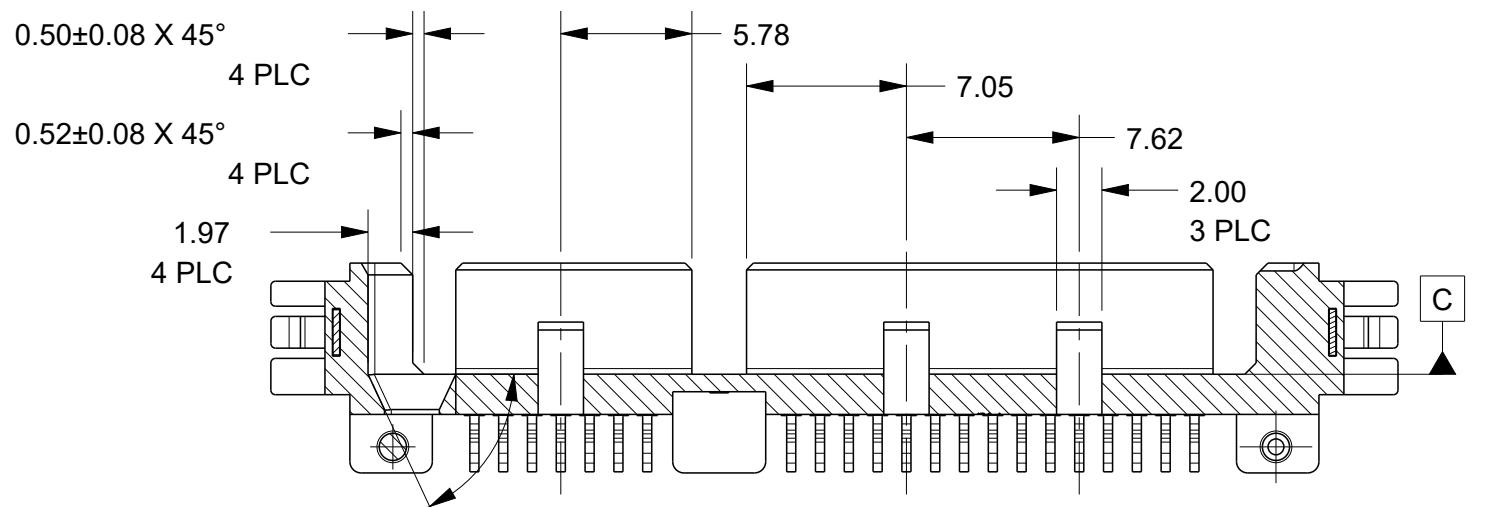
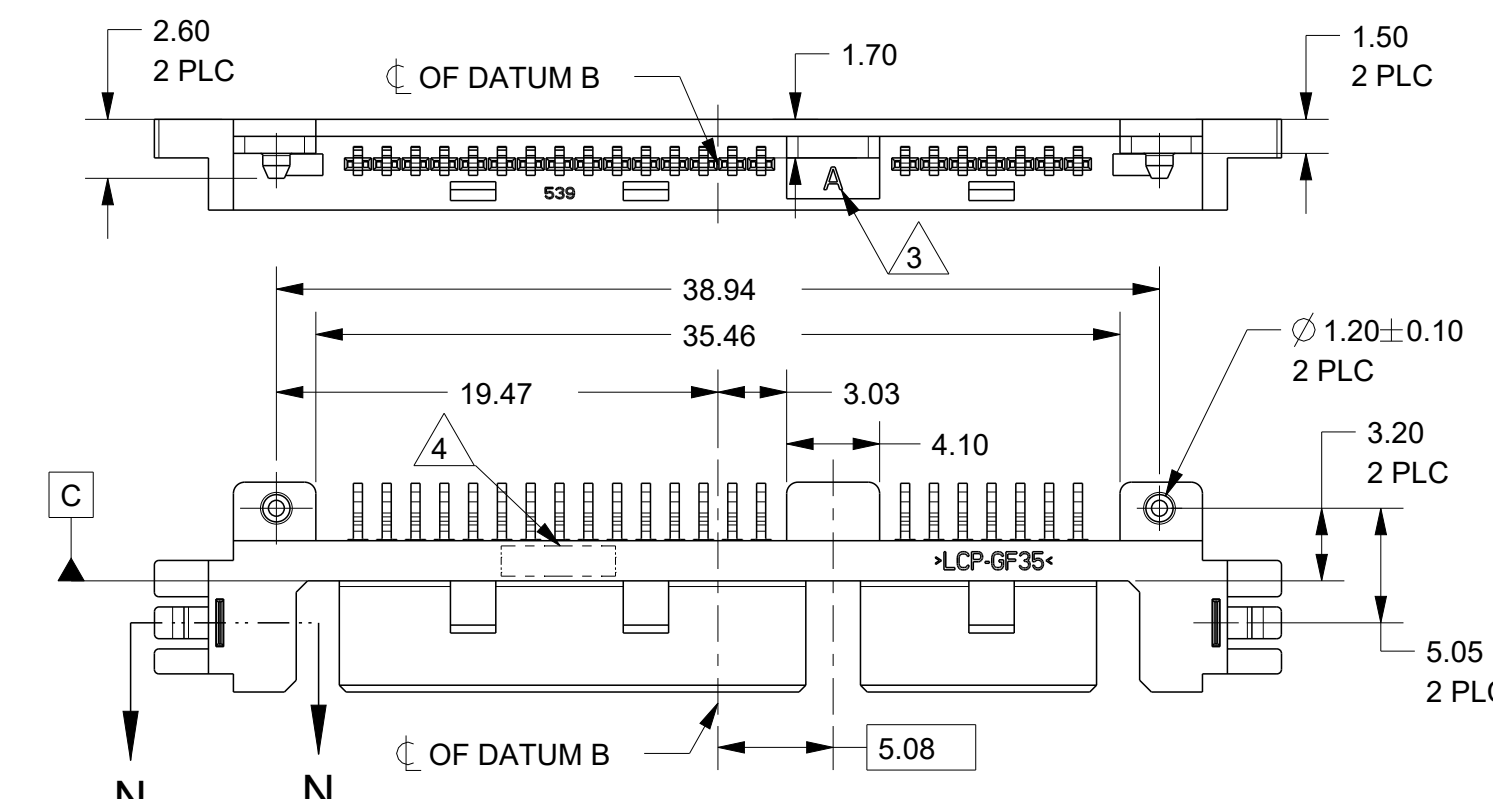

P/N:1735783-1,-2,-3 AS SHOWN

THIS DRAWING IS A CONTROLLED DOCUMENT.		DWN	JASON CHOW	05JAN09	 TE Connectivity	NAME		SLIMLITE SATA PLUG, 15+7P, SMT		
DIMENSIONS: mm		CHK	AP TAY	APVD		SF LEONG	PRODUCT SPEC		108-51052	
TOLERANCES UNLESS OTHERWISE SPECIFIED:		APVD	SF LEONG	APPLICATION SPEC		-		WEIGHT		
0 PLC ±- 1 PLC ±0.20 2 PLC ±0.20 3 PLC ±0.20 4 PLC ±- ANGLES ±2°		WEIGHT		1.43g		SIZE	A3	CAGE CODE	00779	
MATERIAL		FINISH		1		DRAWING NO		C-1735783		
1		2		CUSTOMER DRAWING		SCALE	3:1	SHEET	2 OF 3	
						RESTRICTED TO		-		
						REV		C2		

THIS DRAWING IS UNPUBLISHED.

RELEASED FOR PUBLICATION

© COPYRIGHT

ALL RIGHTS RESERVED.

LOC	DIST	REVISIONS					
DY	-	P	LTR	DESCRIPTION	DATE	DWN	APVD
				SEE SHEET 1			

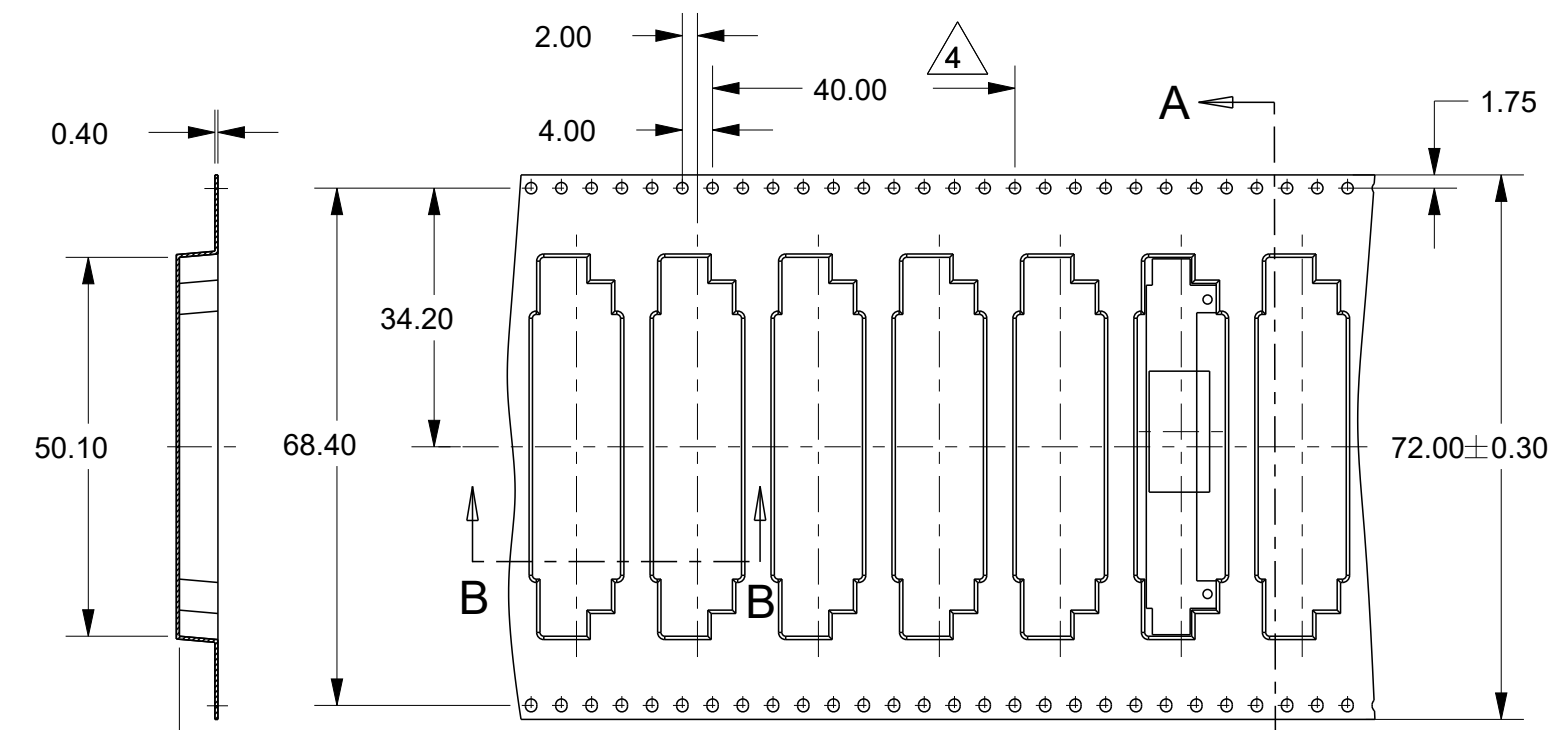

SECTION A-A

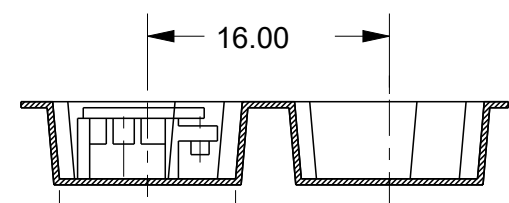

SECTION B-B SCALE 2:1

CUSTOMER DE-REEL DIRECTION

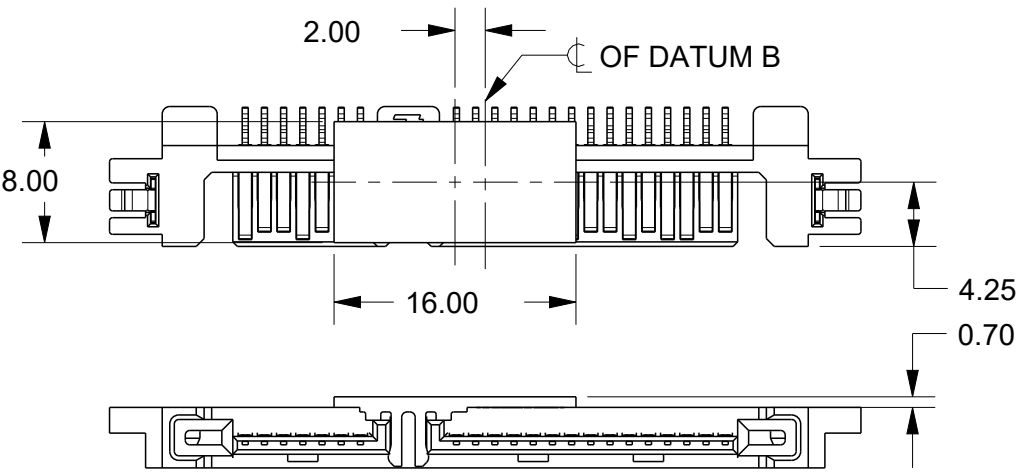

CONNECTOR WITH PICK-UP CAP SCALE 2:1

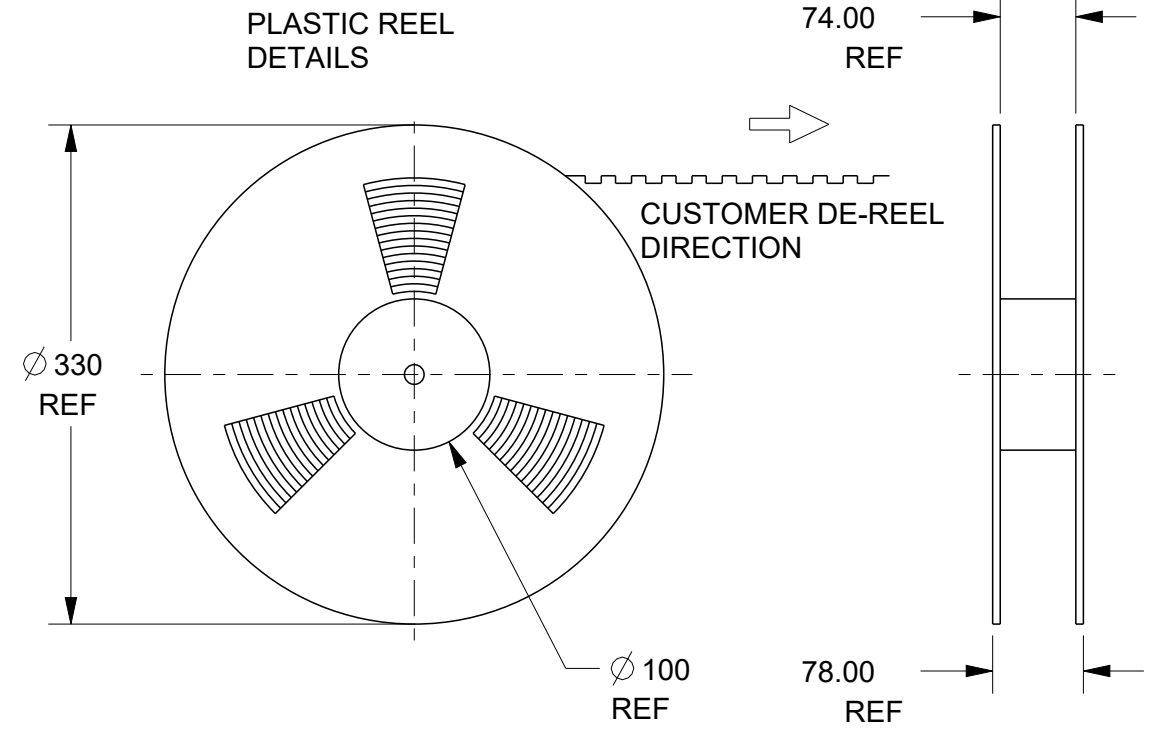

NOTES:

- ALL DIMENSIONS IN MM UNLESS OTHERWISE STATED.
- 2** MATERIAL: PS CLEAR, 0.40±0.05 THICKNESS (BEFORE REFORM).
- GENERAL TOLERANCE: ±0.20MM UNLESS OTHERWISE STATED.
DRAFT ANGLE: 5° (MAX) UNLESS OTHERWISE STATED.
RADIUS: 0.25 (MAX) TYPE UNLESS OTHERWISE STATED.
- 4** ACCUMULATED TOLERANCES FOR PITCHES: ±0.20MM FOR 10 PITCHES.
- DELIVER IN PLASTICS REEL: 757 POCKETS/REEL (700 COMPONENTS/REEL)

P/N:1735783-1,-2,-3 AS SHOWN

THIS DRAWING IS A CONTROLLED DOCUMENT.		DWN JASON CHOW	05JAN09	TE Connectivity	
DIMENSIONS: mm		CHK AP TAY	APVD SF LEONG		
TOLERANCES UNLESS OTHERWISE SPECIFIED:		PRODUCT SPEC 108-51052		SIZE A3	CAGE CODE 00779
0 PLC ±- 1 PLC ±0.20 2 PLC ±0.20 3 PLC ±0.20 4 PLC ±- ANGLES ±5°		APPLICATION SPEC -		DRAWING NO C-1735783	RESTRICTED TO -
MATERIAL 2		WEIGHT 1.43g		SCALE 3:1	SHEET 3 OF 3
CUSTOMER DRAWING				REV C2	