

SIP PIN **SP-1A**

SP-1A-R1000 1000 PIECE ROLL

Now available in rolls of 1000 pieces these are the same SIP Pins used on our breadboard and adaptor products. When placed on boards of .031 in. thickness spring tension holds the pin in position for soldering. The entire pin and board pads are then fluxed and soldered by wave or dip method. For wave soldering fixtures may be needed to hold the assemblies in the proper position. After soldering the header is removed by shearing with lead shears or other suitable methods.

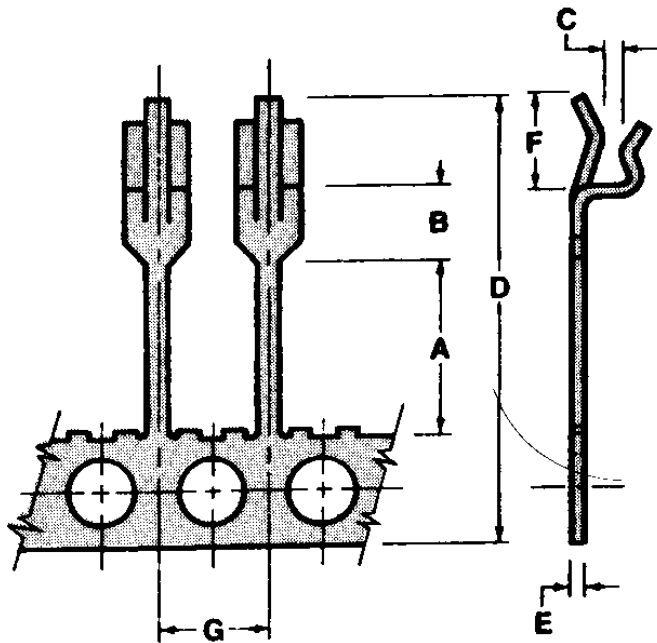

DIM	in.	mm
A	.162	4.11
B	.068	1.72
C	.024	.609
D	.410	10.41
E	.010	.254
F	.080	2.03
G	.100	2.54

SPROCKET HOLES: .062
 NOTE: ACCUMULATION OVER 10 LEADS (G) NOT TO EXCEED .010

TOLERANCES / DECIMAL

XX	+/- .01
XXX	+/- .005
XXXX	+/- .0002

MATERIAL: Pre-Tin Plated Half Hard Phosphor Bronze .010 In. Thick RoHS Compliant
 PACKAGE: Rolls of 1000 pieces with paper interleaf.

Copyright 2008 by Capital Advanced Technologies, Inc. All Rights Reserved. Availability, specifications, and prices are subject to change without notice. All information given is believed to be accurate but is not guaranteed. The user of information given or products represented by such information is responsible for determining the suitability of said information or products for a given purpose. No permission is granted or implied regarding the use of intellectual property or patents owned by Capital Advanced Technologies, Inc. or others by the provision of information or products herein.

CAPITAL ADVANCED TECHNOLOGIES, INC.
Carol Stream, Illinois. USA
 CapitalAdvanced.Com
 Phone 630-690-1696 Fax 630-690-2498