

REVISIONS				
SYM	ZONE	ECN, ERN NO.	DATE	APPRD.
A		PROPOSAL	APR23/13	LCHAN

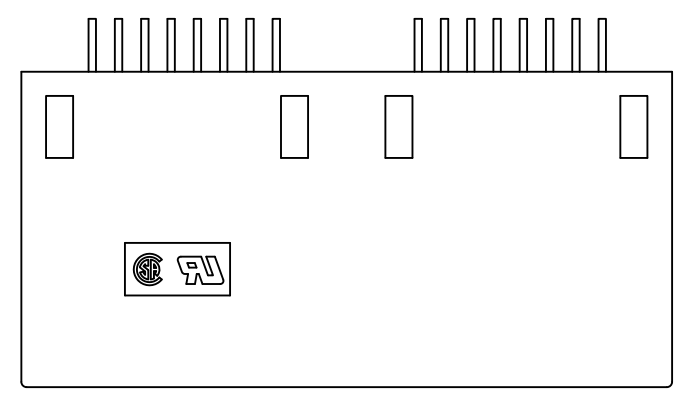

TOP VIEW

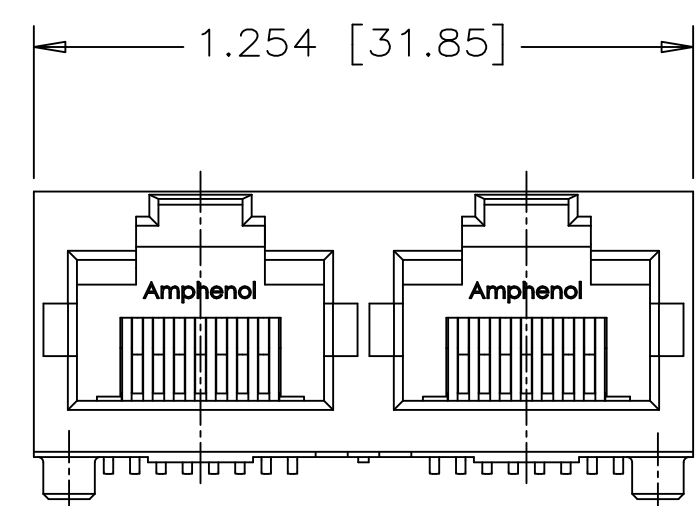

FRONT VIEW

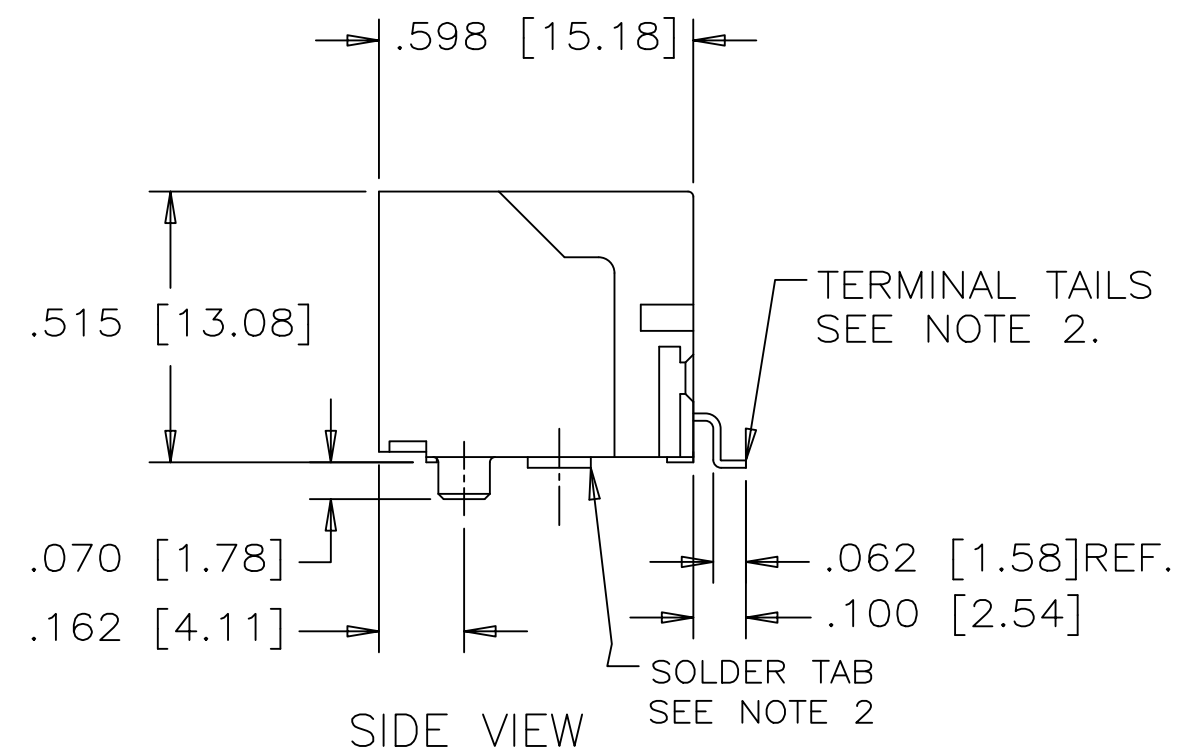

SIDE VIEW

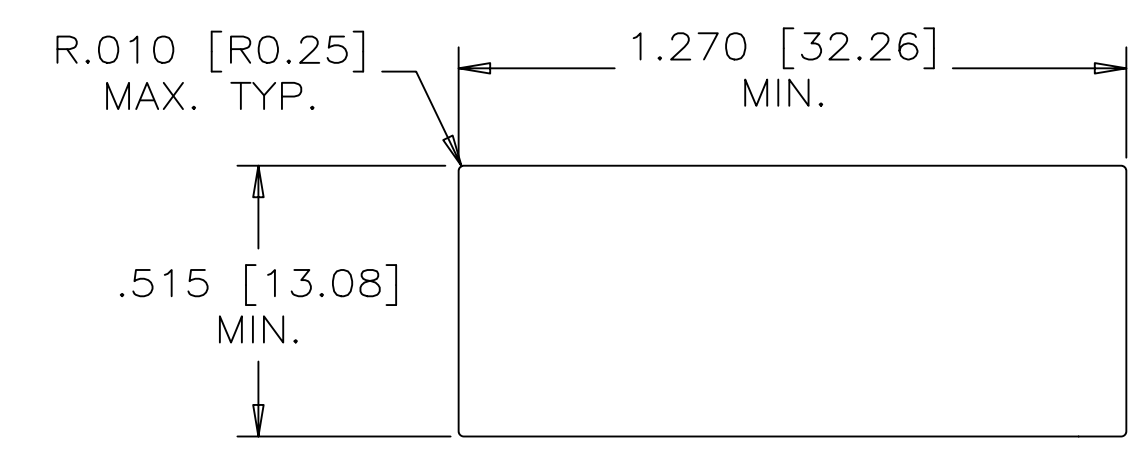

RECOMMENDED PANEL CUTOUT

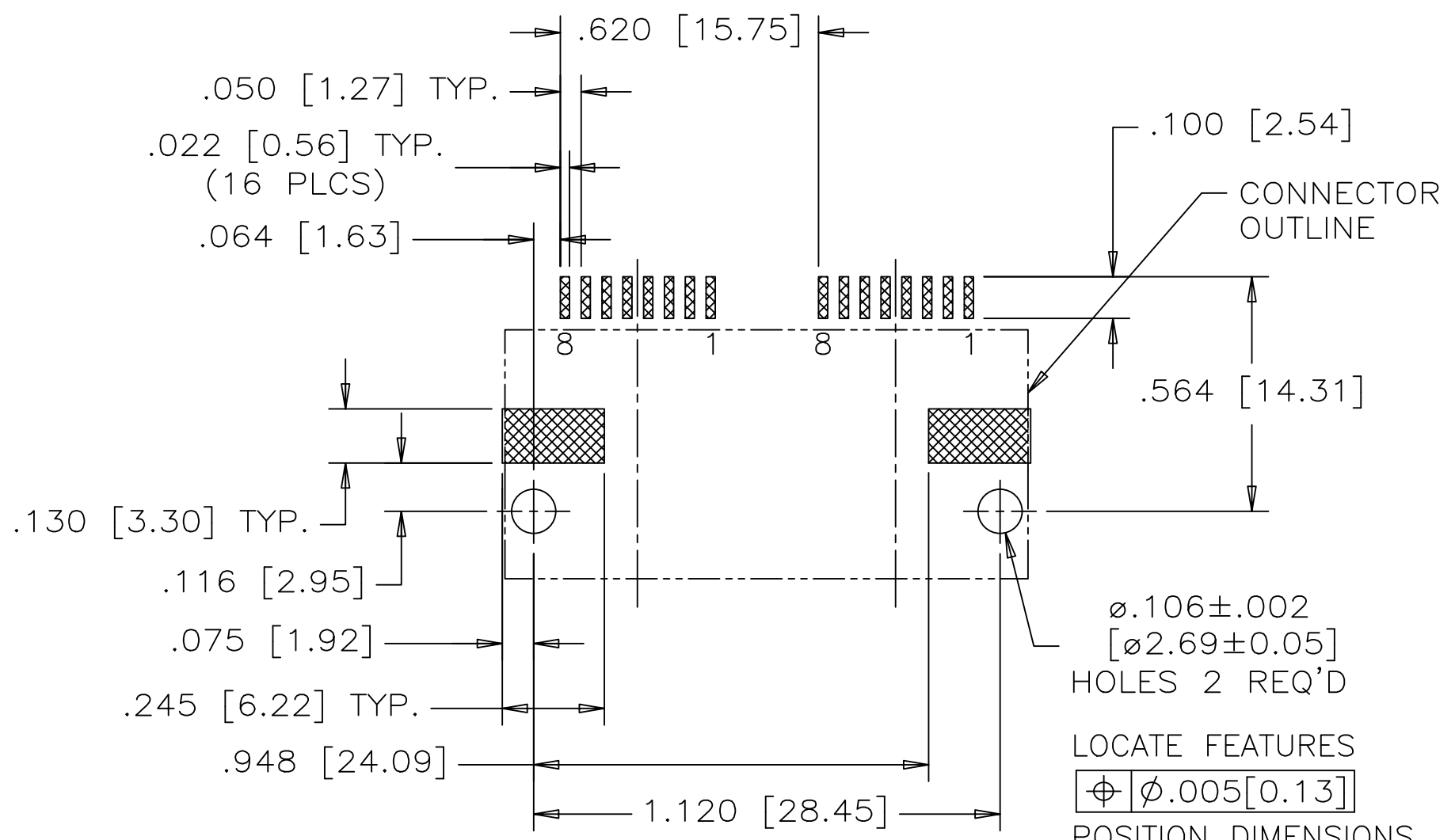

RECOMMENDED P.C.B. LAYOUT
(COMPONENT SIDE OF BOARD)

NOTES

1. MATERIAL:
- HOUSING: HIGH TEMPERATURE THERMOPLASTIC
FLAMMABILITY RATING UL 94V-0
COLOR:BLACK
 - CONTACTS: PHOSPHOR BRONZE
PLATING: 20 μ" [0.508 MICRONS]
MIN. GOLD ON MATING SURFACES.
50 μ" [1.27 MICRONS]
MIN. NICKEL UNDERPLATE
100 μ" [2.54 MICRONS]
MIN. MATTE TIN OR GOLD FLASH
ON CONTACT TAILS.
 - SOLDER TAB: COPPER ALLOY WITH TIN PLATING.
2. COPLANARITY SPECIFICATION:
WITH THE MODULAR JACK SITTING ON A
LEVEL SURFACE, THE MAXIMUM GAP BETWEEN
THE LEVEL SURFACE AND ALL TERMINAL TAILS
AND BOTH FITTING NAILS IS .004 [0.10].

AMPHENOL PART NUMBER: RJSSE-5080-02T



DRAWN	AMY.Z	DATE	APR23/13	Amphenol Canada Corp.	
DESIGNED					
CHECKED	LCHAN	DATE	APR23/13	TITLE	
I. E. APPRD.				2 PORTS SURFACE MOUNT JACK, UNSHIELDED, WITH HOLD DOWN BRACKET, 8 POSITION & 8 CONTACTS (T&R PACKAGE)-RoHS COMPLIANT	
Q. A. APPRD.				DWG	DRAWING NO.
DWG. APPRD.				P-RJSSE-5080-02T	
ENG. REL. NO.				REV.	A
REF.				SCALE	WT. ----- SURF. ----- SHEET 1 OF 2
DIMENSIONS ARE IN	CODE ID. NO.				
INCHES [mm]	03554				

THIS DOCUMENT CONTAINS PROPRIETARY INFORMATION AND SUCH INFORMATION
MAY NOT BE DISCLOSED TO OTHERS FOR ANY PURPOSE OR USED FOR MANUFACTURING
PURPOSES WITHOUT WRITTEN PERMISSION FROM AMPHENOL CANADA CORP.

REVISIONS				
SYM	ZONE	ECN, ERN NO.	DATE	APPRD.
A		PROPOSAL	APR23/13	LCHAN

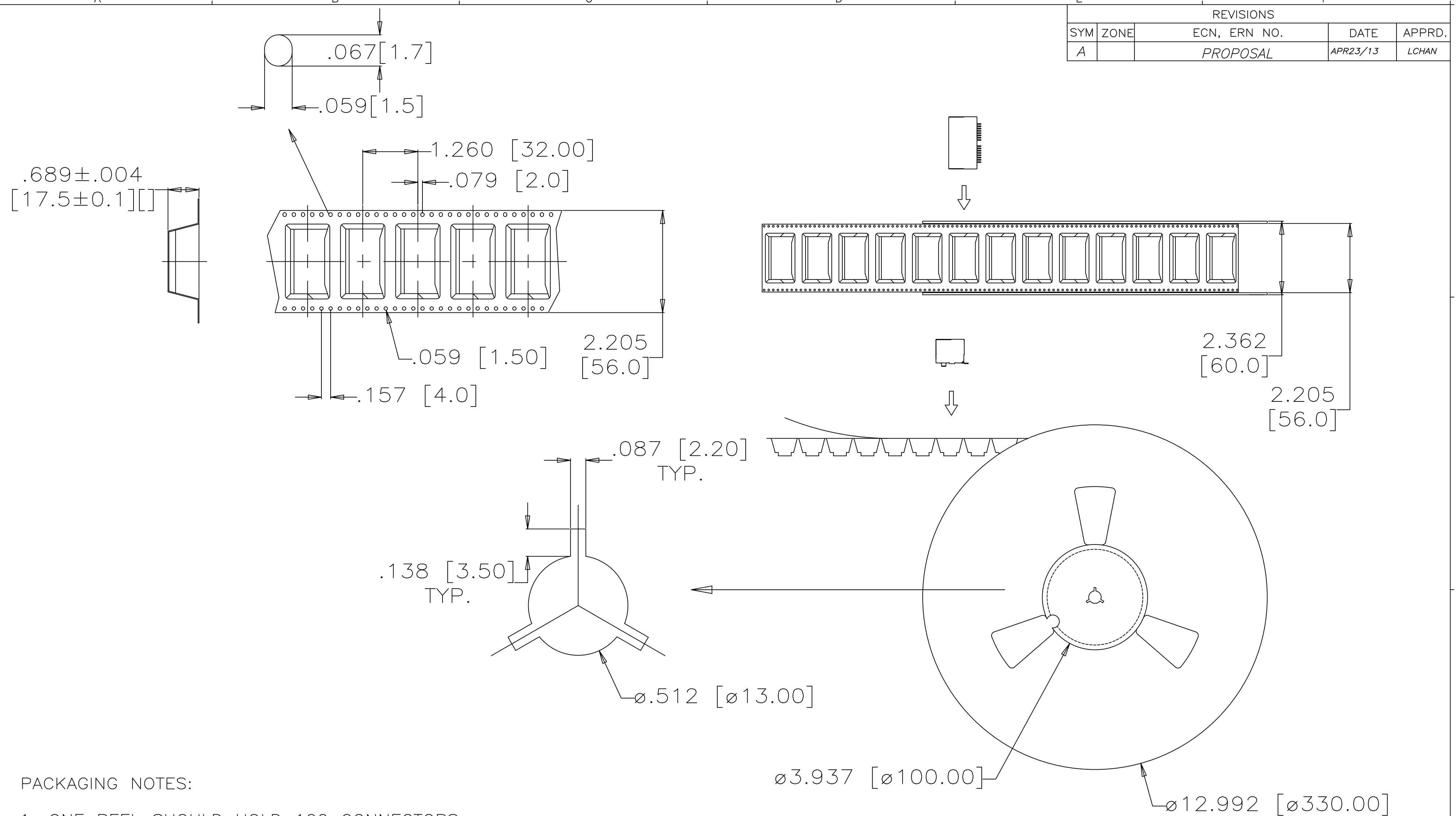

PACKAGING NOTES:

1. ONE REEL SHOULD HOLD 100 CONNECTORS.
2. 10 EMPTY CAVITIES FOR BOTH TOP AND BOTTOM OF THE CARRIER.
3. A FULLY LOADED CARTON SHOULD CONTAIN 5 REELS (500 PCS) OF CONNECTOR.



DRAWN	AMY.Z	DATE	APR23/13
DESIGNED			
CHECKED	L.CHAN	DATE	APR23/13
I. E. APPRD.			
Q. A. APPRD.			
DWG. APPRD.			
ENG. REL. NO.			
REF.			
DIMENSIONS ARE IN	CODE ID. NO.		
INCHES [mm]	03554		

Amphenol Canada Corp.			
TITLE 2 PORTS SURFACE MOUNT JACK, UNSHIELDED, WITH HOLD DOWN BRACKET, 8 POSITION & 8 CONTACTS T&R PACKAGE DRAWING-RoHS COMPLIANT			
DWG	DRAWING NO.	REV.	
C	P-RJSSE-5080-02T	A	
SCALE	WT. -----	SURF. -----	SHEET 2 OF 2

THIS DOCUMENT CONTAINS PROPRIETARY INFORMATION AND SUCH INFORMATION MAY NOT BE DISCLOSED TO OTHERS FOR ANY PURPOSE OR USED FOR MANUFACTURING PURPOSES WITHOUT WRITTEN PERMISSION FROM AMPHENOL CANADA CORP.