

THIS COPY IS PROVIDED ON A RESTRICTED BASIS AND IS NOT TO BE USED IN ANY WAY DETRIMENTAL TO THE INTERESTS OF PANDUIT CORP.

PANDUIT PART #	STUD SIZE	DIMENSIONS - in [mm]				
		A ± .03 [0,8]	W ± .01 [0,3]	C ± .02 [0,51]	M ± .03 [0,8]	H ± .01 [0,3]
PN22-4F	#2	.67 [17,02]	.20 [5,08]	.21 [5,33]	.57 [14,49]	.12 [3,05]
PN22-6F	#6	.77 [19,56]	.25 [6,35]	.26 [6,60]	.63 [16,00]	.15 [3,81]

INSTALLATION TOOLS
CT-520
CT-1525 (A POCKET)
CT-2500 (CT-2525CH: A PKT)

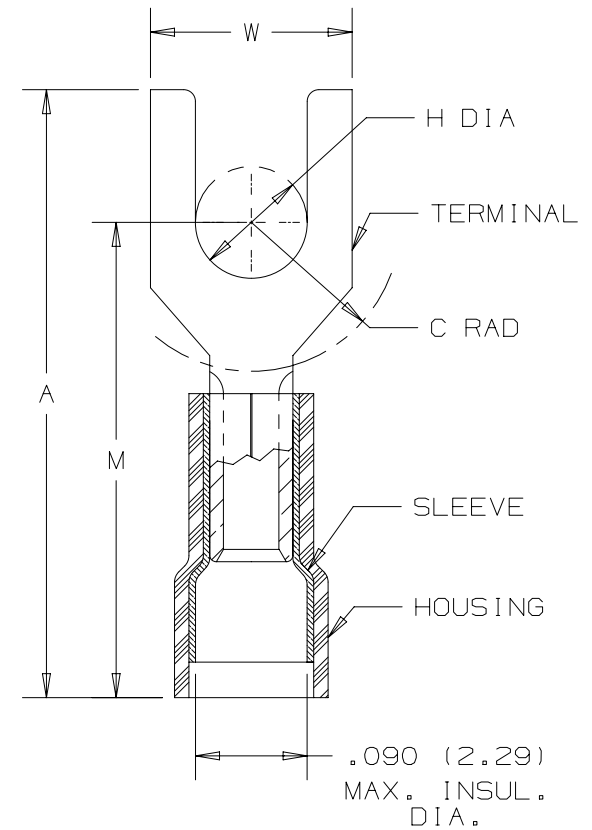

NOTES:

1. RECOMMENDED FOR:

- A. #26-22 AWG SOLID OR STRANDED COPPER WIRE
- B. 221° [105°C] MAX TEMP. RATING
- C. 300V MAX VOLTAGE RATING

2. MATERIAL:

- A. STAMPING: .02" [0,5] THK COPPER, TIN PLATED
- B. HOUSING: NYLON, YELLOW
- C. SLEEVE: BRASS, TIN PLATED

3. SEE www.panduit.com FOR PACKAGE QUANTITIES

4. DIMENSIONS IN BRACKETS ARE IN MILLIMETERS

5. WIRE STRIP LENGTH: $3/16" \begin{matrix} +1/32 \\ -0 \end{matrix}$ [4,8mm $\begin{matrix} +0,8 \\ -0 \end{matrix}$]

REV	DATE	BY	CHK	APR	DESCRIPTION	ECN
08	04-27-15	TMR	JHNU	RGB	ADDED CT-1525 CT-2500 TOOL, UPDATED TOOL FORMAT	A41235
07	04-26-13	JBN	RTFI	RTFI	UPDATED DRAWING BORDER & TITLE BLOCK	A41235

TITLE						
FORK TERMINAL, NYLON INSULATED #26-22 AWG						
CONTROL DRAWING						
ITEM REVISION NAME					N41235BA/08	
DATASET FILE NAME					N41235BA_DC/08	
UNLESS OTHERWISE SPECIFIED, DIMENSIONAL TOLERANCES ARE: IN [mm]					MATERIAL:	
.x ± .1 [2.54] .xxx ± .005 [.127]					PANDUIT	
.xx ± .01 [.25] ANGLES ± 5 °					SEE NOTES	
					DRAWING NUMBER:	
THIRD ANGLE PROJECTION					A41235	
DRAWN BY	DATE	CHK	SCALE	SHT 1 OF 1		
DAW	-	-	NONE	A		

D10100DA/16