

**STRAIGHT PLUG SOLDER TYPE
CABLE .250**

R161.054.000
SERIES N

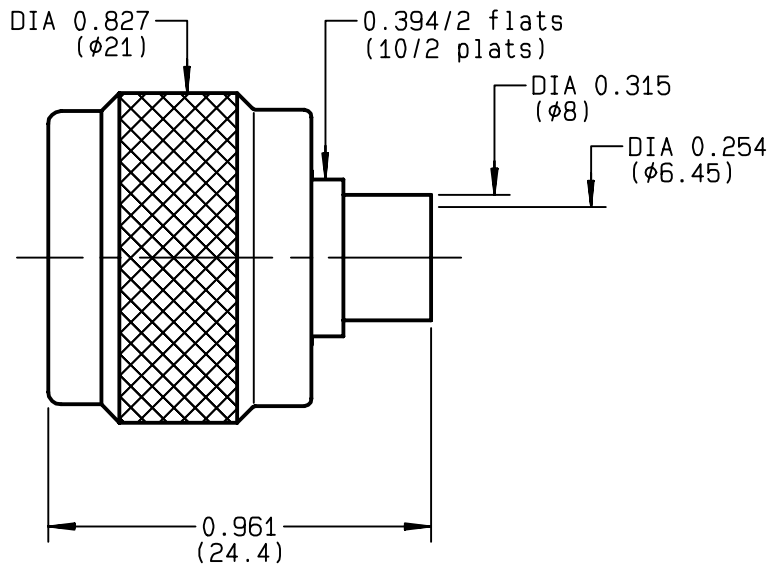

NOMINAL IMPEDANCE	50 Ω	CABLES : KS 3 RG 401
FREQUENCY RANGE	0-11 GHz	
TEMPERATURE RATING	-55/+105 °C	
V.S.W.R	1.25 + x F(GHz)Maxi	
RF INSERTION LOSS	0.048 √F(GHz) dB Maxi	
VOLTAGE RATING	1400 Veff Maxi	
DIELECTRIC WITHSTANDING VOLTAGE	2500 Veff Mini	
INSULATION RESISTANCE	5000 MΩMini	
HERMETIC SEAL	NA Atm.cm ³ /s	
LEAKAGE (pressurized only)	NA	
MECHANICAL DURABILITY	500 Cycles	OTHERS CHARACTERISTICS
WEIGHT	25 gr	CABLE RETENTION 500 N Mini
SPECIFICATION		CENTER CONTACT RETENTION
		Axial force - mating end NA N Mini
		Axial force - opposite end NA N Mini
		Torque NA cm.N Mini
		RECOMMENDED TORQUES
		Mating 130 cm.N
		Panel nut NA cm.N
		Clamp nut NA cm.N

CONNECTOR PARTS	MATERIALS	FINISH	(all values are given) in micrometers
BODY	BRASS	GOLD 0.2 OVER NICKEL 2	
OUTER CONTACT	BRASS	GOLD 0.2 OVER NICKEL 2	
CENTER CONTACT	BRASS	GOLD 0.5 OVER NICKEL 2	
INSULATOR	PTFE	-	
GASKET	SILICONE RUBBER	-	
OTHERS PIECES	BRASS	BBR 2	

ISSUE	CREATION DATE	FILE PART-NUMBER
9834K01	08/02/1993	EPC 96-07



BONMINI

The information given here is subject to change without notice.
Design changes may be in order to improve the product .

Connect to the future



R161.054.000

ISSUE **9834K01** SERIES **N**

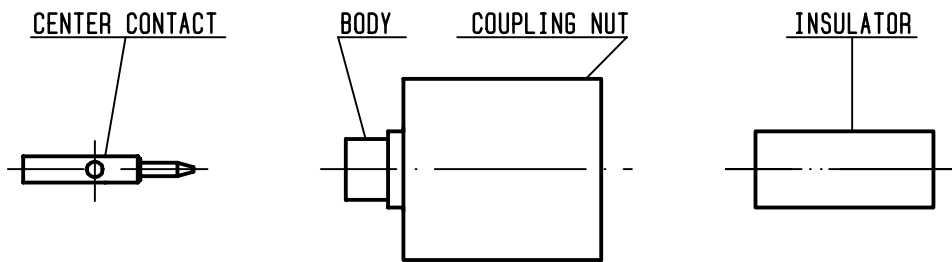

①

Take the tool kit : R 282 125 010 .
Strip the dielectric of the cable .
Stripping tool cable : R 282 054 .
Trimmer : R 282 074 020 .
Clean the cable .
-

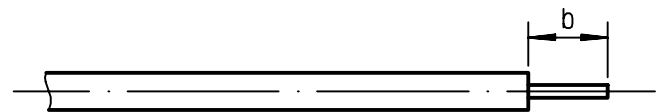

Stripping	a	b	c	d	e
inch	0	0.177 0	0	0	0
mm		4.5			

②

Screw the positioner R 282 744 261 onto the soldering jig R 282 740 030 .
Slide contact into positioner .
Insert solder gauge R 282 862 080 between contact and cable .
Tighten and solder the contact .

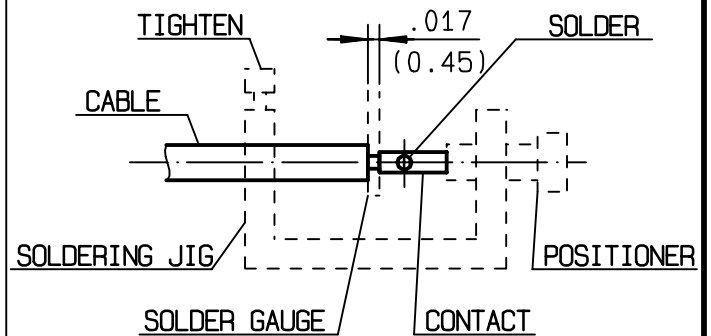

③

After cooling remove cable assembly from the jig .
Screw positioner R 282 744 350 into the connector .
Slide cable into the connector until it bottoms against positioner R 282 744 350 .
Tighten .
Put 3 rings of solder around the cable and solder .

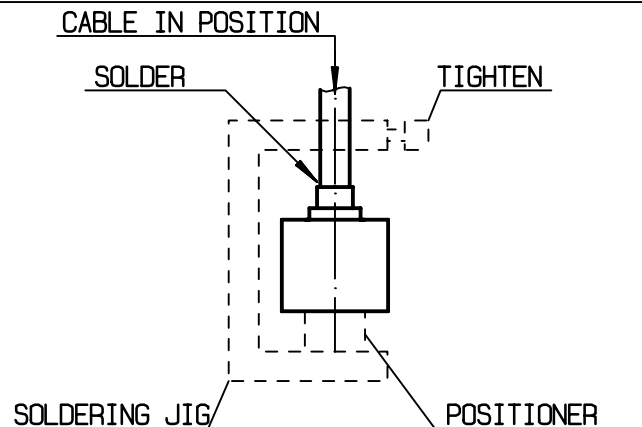

④

After cooling remove cable assembly from the jig .
Screw female dielectric insert tool onto connector and cut the excess of dielectric with the dielectric recess tool R282 915 040 .
Insert insulator with the dielectric plunger .
Dielectric insert tool and dielectric plunger : R282 730 160 .

