



American Opto Plus LED Corp.

L955T-MEC

3.5 x 2.8 x 0.7mm High Output Red PLCC-2

MAIN FEATURES:

- Low current requirement
- Wide viewing angle
- IR Reflow Soldering
- I.C. compatible

FEATURES:

- High Luminous Output Function Red SMD LED (AlInGaP/AIn)
- PLCC-2 3.5 x 2.8mm standard package with heat sink
- High reliability package
- Wide viewing angle 120 degree
- Available in 8mm carrier tape on 7 inch reel (2000 pieces)

PACKAGE OUTLINES:

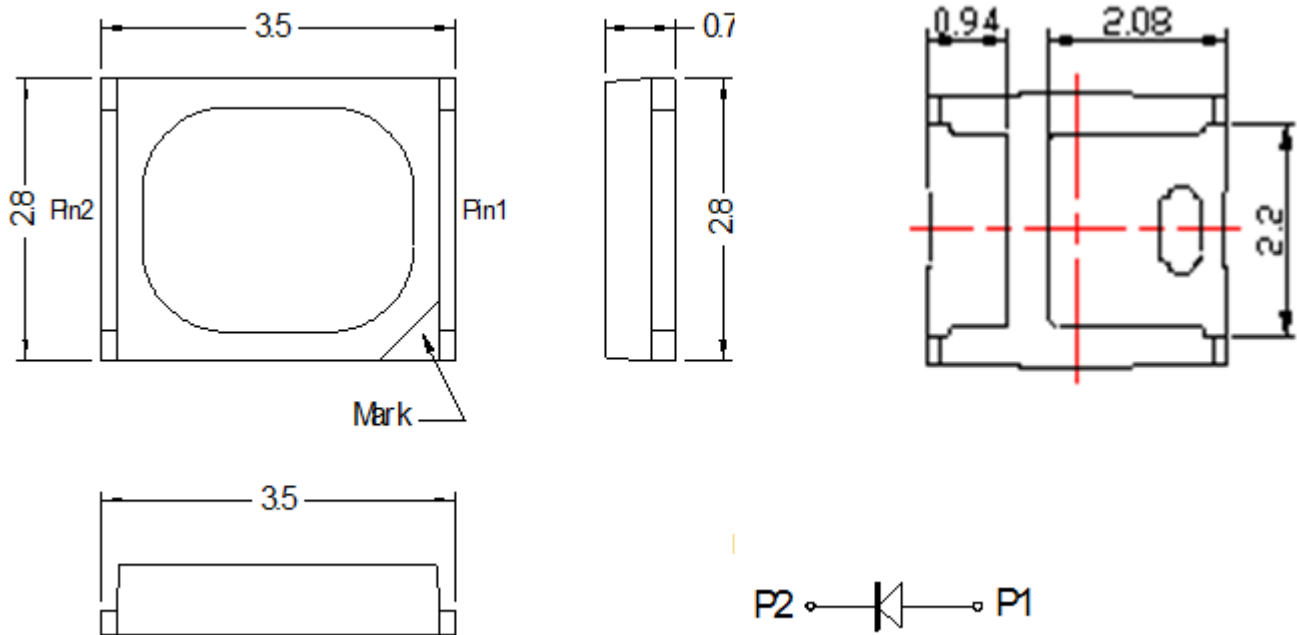

Item	Materials
Package	Heat-Resistant Polymer
Encapsulating Resin	Silicone
Electrodes	Ag Plating Copper Alloy

NOTES:

1. All dimensions are in millimeters (inches);
2. Electrical Connection between all Cathodes is Recommended
3. Specification is preliminary



American Opto Plus LED Corp.

L955T-MEC

3.5 x 2.8 x 0.7mm High Output Red PLCC-2

MAIN FEATURES:

- Low current requirement
- Wide viewing angle
- IR Reflow Soldering
- I.C. compatible

ABSOLUTE MAXIMUM RATINGS

(Ta=25°C)

Item	Symbol	Max Rating	Unit
DC Forward Current	I _F	250	mA
Peak Pulsed Forward Current	I _{FP}	300	mA
Reverse Voltage	V _R	--	V
Junction Temperature	T _j	125	°C
Junction/ Solder Point	R _{th Js}	100	°C/W
Junction/ Ambient	R _{th Ja}	115	°C/W
Power Dissipation	P _d	625	mW
Operating Temperature Range	T _{OPR}	-30 ~ +100	°C
Storage Temperature	T _{STG}	-40 ~ +100	°C
Solder Temperature	T _{SOL}	265°C for 10 sec	

IFP Conditions: Pulse Width ≤ 10 msec and Duty ≤ 1/10

OPTICAL-ELECTRICAL CHARACTERISTICS

(Ta=25°C)

Parameter	Symbol	Test Condition	Min	Typ	Max	Unit
Forward Voltage	V _F	I _F = 150mA	--	2.1	2.5	V
Luminous Flux	Φ _V		--	14	--	lm
Luminous Intensity	I _V		2500	4500	7200	mcd
Reverse Current	I _R	V _R = 5V			50	μA
Dominant Wavelength	λ _D	I _F =20mA	615	625	635	nm
Peak Wavelength	λ _P		--	635	--	nm
Spectral Half Width	Δλ _{1/2}		--	17	--	nm
Reverse Current	I _R	V _R =5V			50	μA

Notes: Luminous Intensity Tolerance: ±10%

Please refer to CIE 1931 Chromaticity Diagram



American Opto Plus LED Corp.

L955T-MEC

3.5 x 2.8 x 0.7mm High Output Red PLCC-2

MAIN FEATURES:

- Low current requirement
- Wide viewing angle
- IR Reflow Soldering
- I.C. compatible

LUMINOUS INTENSITY BIN TABLE

$I_F=150mA$

Rank Name	Min (mcd)	Max (mcd)
U	3200	4200
V	4200	5500
W	5500	7200

Tolerance for each bin is $\pm 10\%$

VOLTAGE BIN TABLE

$I_F=150mA$

Rank Name	Min (nm)	Max (nm)
1	615	620
2	620	625
3	625	630
4	630	635

Tolerance for each bin is $\pm 1nm$

Note:

1. One delivery will include several color ranks and I_V ranks of products.
The quantity-ratio of the different rank is decided by AOP.
2. Bin Name typed on the Label: I_V Rank + Color Rank.
For example, **Bin V2 means I_V : 4200~5500mcd and Color: 620~625nm.**
3. AOP has the right to update the information without notice.
Please confirm the spec details before placing an order.



American Opto Plus LED Corp. L955T-MEC

3.5 x 2.8 x 0.7mm High Output Red PLCC-2

MAIN FEATURES:

- Low current requirement
- Wide viewing angle
- IR Reflow Soldering
- I.C. compatible

OPTICAL CHARACTERISTIC CURVES

Forward Current vs. Forward Voltage

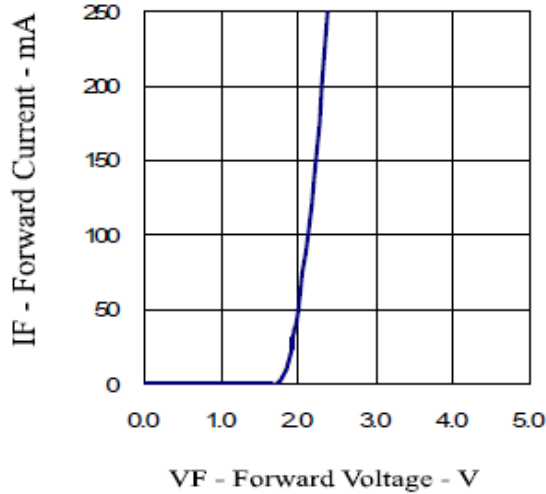

Relative Intensity vs. Forward Current

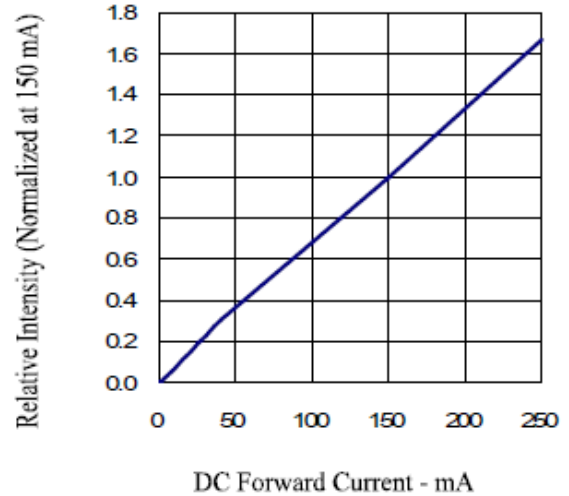

Forward Current vs. Ambient Temperature

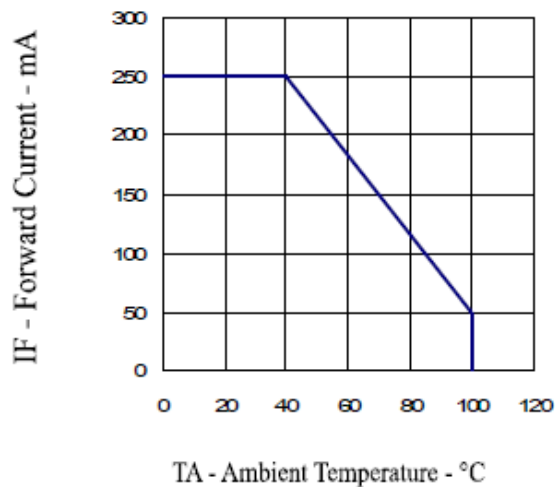

Relative Intensity vs. Wavelength

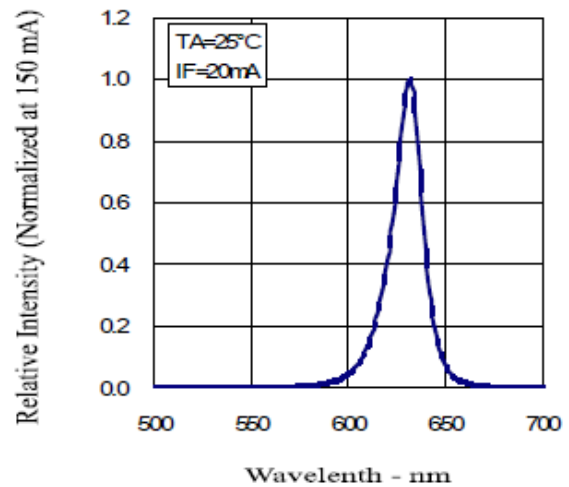



American Opto Plus LED Corp.

L955T-MEC

3.5 x 2.8 x 0.7mm High Output Red PLCC-2

MAIN FEATURES:

- Low current requirement
- Wide viewing angle
- IR Reflow Soldering
- I.C. compatible

RADIATION PATTERN

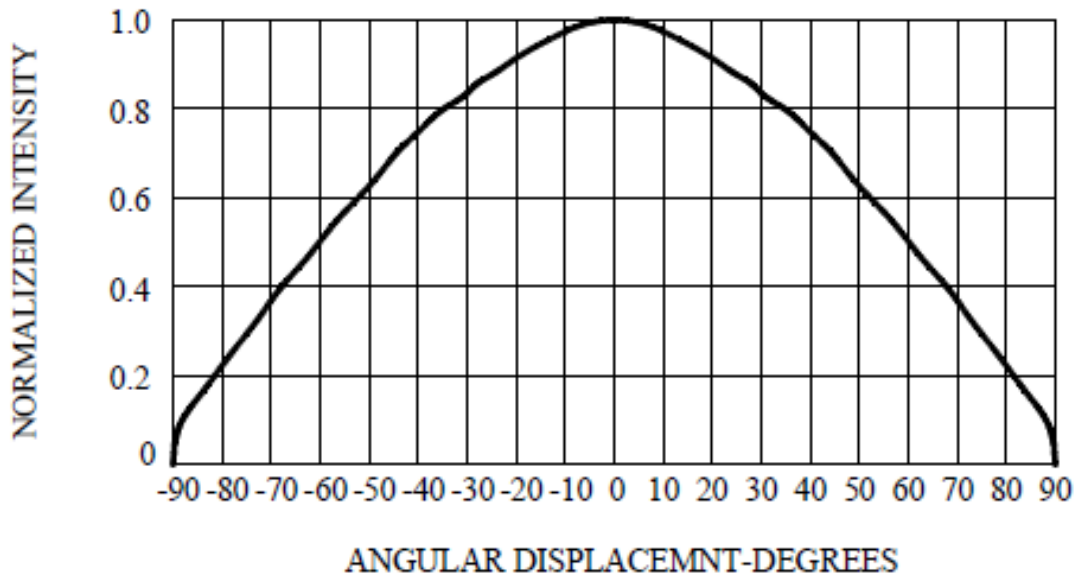

Recommended Soldering Pad Pattern

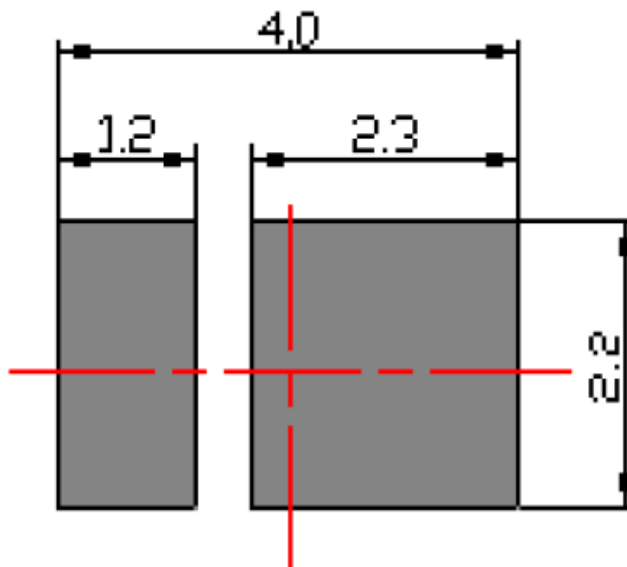



American Opto Plus LED Corp.

L955T-MEC

3.5 x 2.8 x 0.7mm High Output Red PLCC-2

MAIN FEATURES:

- Low current requirement
- Wide viewing angle
- IR Reflow Soldering
- I.C. compatible

SOLDERING CONDITIONS:

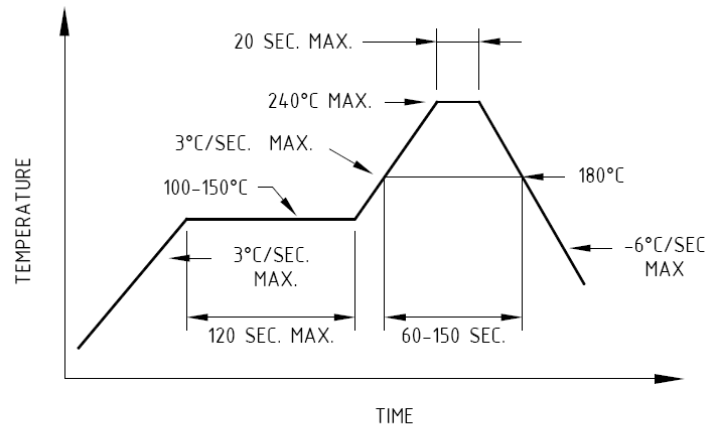

Recommended reflow soldering profile

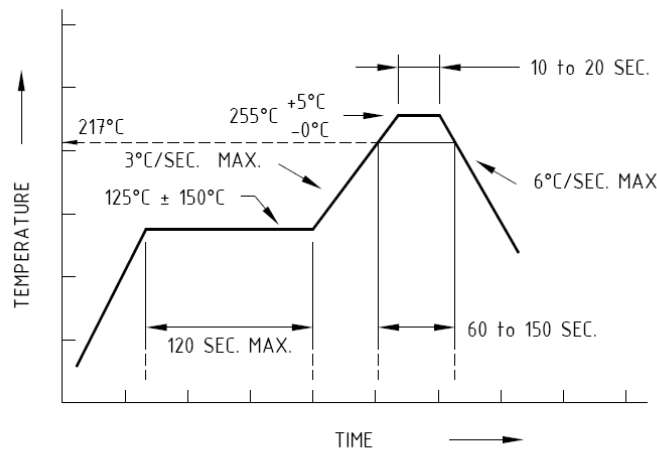

Recommended Pb-free reflow soldering profile

- Repairing should not be done after the LEDs have been soldered. When repairing is unavoidable, a double-head soldering iron should be used. It should be confirmed beforehand whether the characteristics of the LEDs will or will not be damaged by repairing.
- Reflow soldering should not be done more than two times.
- When soldering, do not put stress on the LEDs during heating.
- After soldering, do not warp the circuit board.



American Opto Plus LED Corp.

L955T-MEC

3.5 x 2.8 x 0.7mm High Output Red PLCC-2

MAIN FEATURES:

- Low current requirement
- Wide viewing angle
- IR Reflow Soldering
- I.C. compatible

TAPE DIMENSIONS

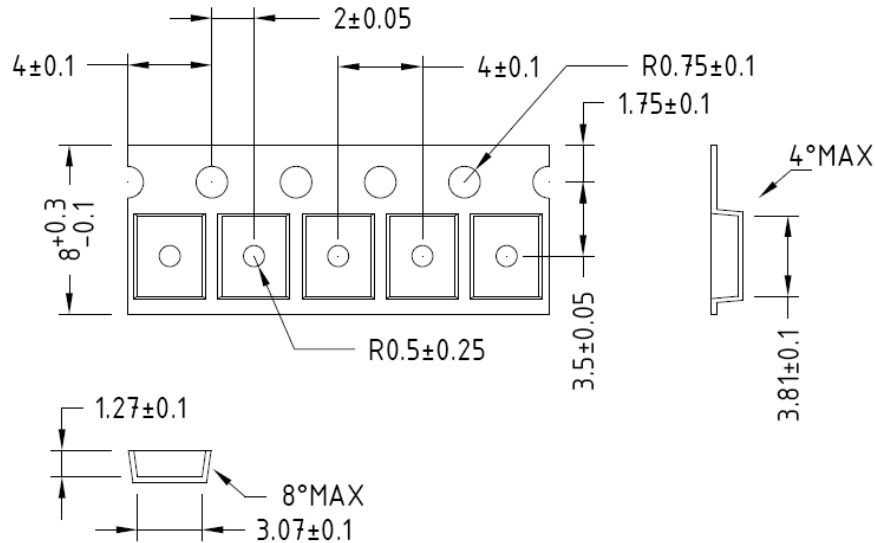

TAPE LEADER AND TRAILER DIMENSION

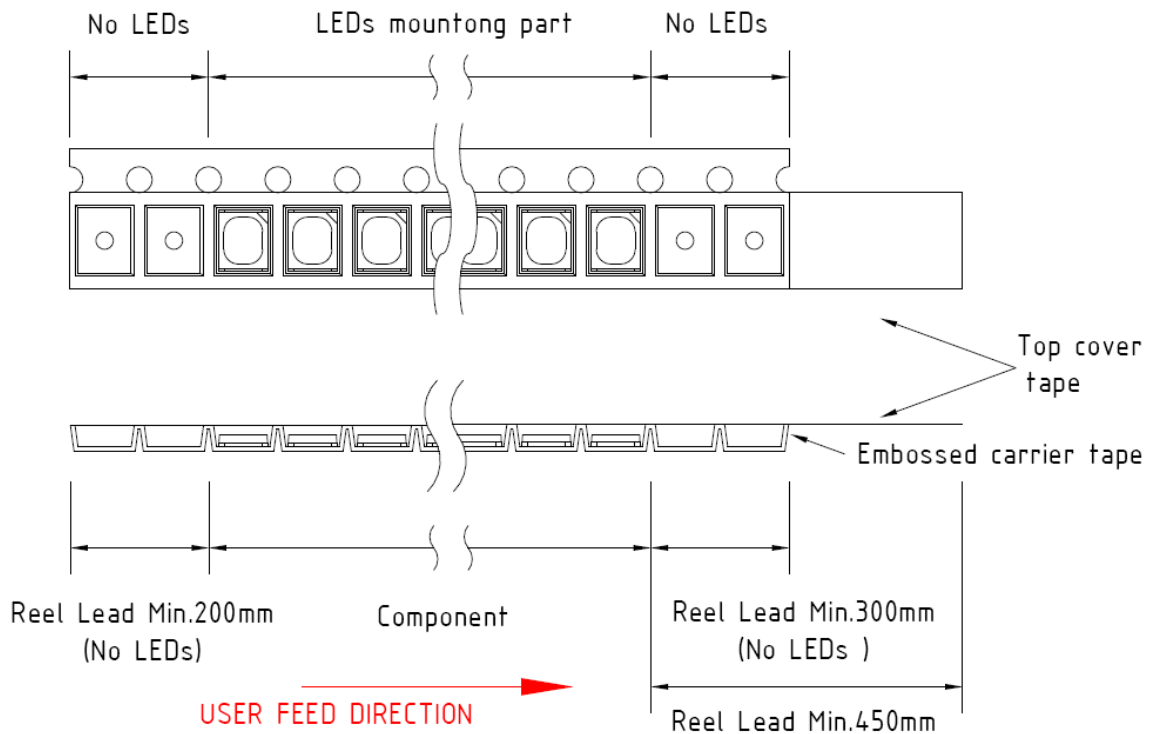



American Opto Plus LED Corp.

L955T-MEC

3.5 x 2.8 x 0.7mm High Output Red PLCC-2

MAIN FEATURES:

- Low current requirement
- Wide viewing angle
- IR Reflow Soldering
- I.C. compatible

REEL DIMENSION

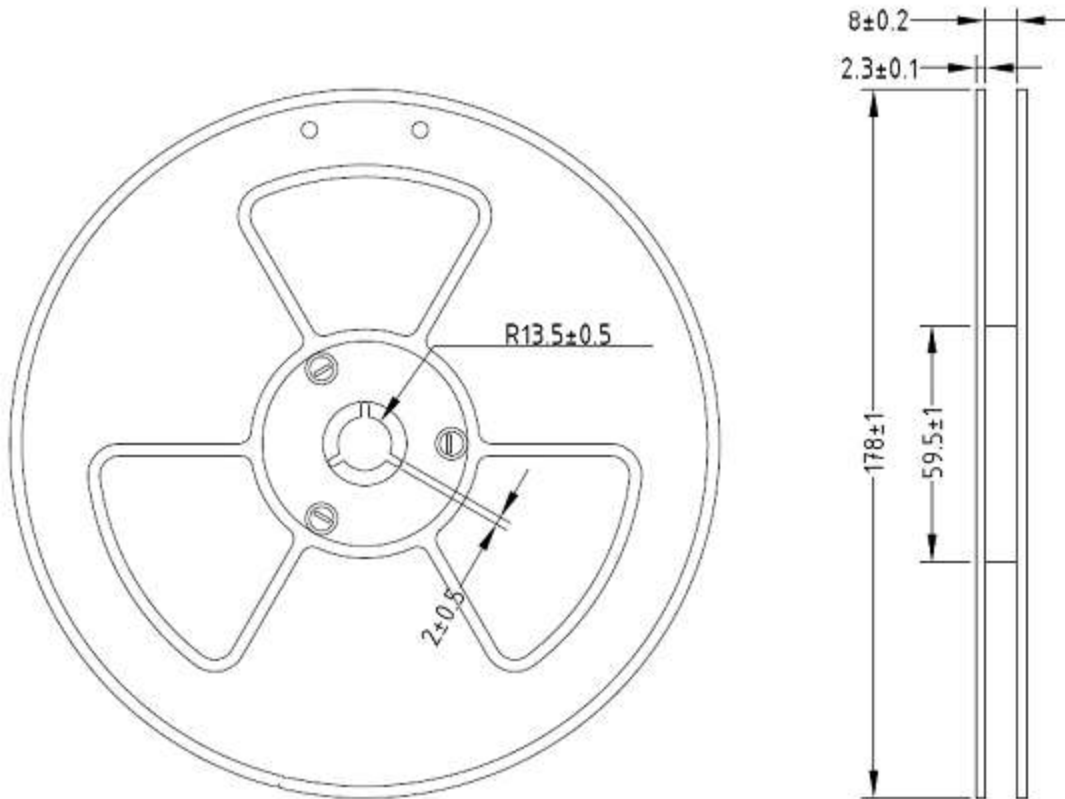

Note: Baking is required under the following conditions:

The pack has been open for more than four weeks.

Baking recommended conditions.

60 ± 5 °C for 20 hours.



American Opto Plus LED Corp.

L955T-MEC

3.5 x 2.8 x 0.7mm High Output Red PLCC-2

MAIN FEATURES:

- Low current requirement
- Wide viewing angle
- IR Reflow Soldering
- I.C. compatible

MOISTURE SENSITIVITY

AOP's SMD LEDs are shipped in sealed, moisture-barrier bags (MBB) designed for long shelf life. If SMD LED has exposed with moist environments before soldering, this may cause damage to SMD LED during soldering (reflow) operation.

STORAGE/ FLOOR TIME

Condition	Temperature(C)	Humidity(RH)	Period of Time
Before Open	30	60	6 month from shipping date
After Open	30	60	Within 48 hours

- MSL of this product are MSL4, please see IPC/JEDEC STD020D for more detail.
- LEDs reach floor time may be damaged while soldering/ reflow processing, please discard the LED.
- If RH indicator card show 60% RH when unseal the package, please bake/ discard the LED.

RESEAL

- AOP's aluminum MBB may reuse as to reseal the unused LED if MBB has not been damaged or had any holes on it.
- Moisture absorbent material (silica gel) may be reuse if it does not become pink.
- Proper resealed LED's floor time will not reset, only stop counting until open.
- If RH indicator card show 60% RH when open the package, please bake/ discard the LED.