



# Pentium® III Processor for the PGA370 Socket at 500 MHz to 1.13 GHz

Datasheet

Revision 8

## Product Features

- Available in 1.13 GHz, 1B GHz, 933, 866, 800EB, 733, 667, 600EB, and 533EB MHz for a 133 MHz system bus
- Available in 1.10 GHz, 1 GHz, 900, 850, 800, 750, 700, 650, 600E, 550E, and 500E MHz for a 100 MHz system bus
- System bus frequency at 100 MHz and 133 MHz (“E” denotes support for Advanced Transfer Cache and Advanced system buffering; “B” denotes support for a 133 MHz system bus where both bus frequencies are available for order per each given core frequency; See Table 1 for a summary of features for each line item.)
- Available in versions that incorporate 256-KB Advanced Transfer Cache (on-die, full speed Level 2 (L2) cache with Error Correcting Code (ECC))
- Dual Independent Bus (DIB) architecture: Separate dedicated external System Bus and dedicated internal high-speed cache bus
- Internet Streaming SIMD Extensions for enhanced video, sound and 3D performance
- Binary compatible with applications running on previous members of the Intel microprocessor line
- Dynamic execution micro architecture
- Intel Processor Serial Number
- Power Management capabilities
  - System Management mode
  - Multiple low-power states
- Optimized for 32-bit applications running on advanced 32-bit operating systems
- Flip Chip Pin Grid Array (FC-PGA/FC-PGA2) packaging technology; FC-PGA/FC-PGA2 processors deliver high performance with improved handling protection and socketability
- Integrated high performance 16-KB instruction and 16-KB data, nonblocking, level one cache
- 256-KB Integrated Full Speed level two cache allows for low latency on read/store operations
- Double Quad Word Wide (256 bit) cache data bus provides extremely high throughput on read/store operations.
- 8-way cache associativity provides improved cache hit rate on reads/store operations.
- Error-correcting code for System Bus data
- Enables systems which are scaleable for up to two processors

The Pentium® III processor is designed for high-performance desktops and for workstations and servers. It is binary compatible with previous Intel Architecture processors. The Pentium III processor provides great performance for applications running on advanced operating systems such as Windows® 98, Windows NT and UNIX\*. This is achieved by integrating the best attributes of Intel processors—the dynamic execution, Dual Independent Bus architecture plus Intel MMX™ technology and Internet Streaming SIMD Extensions—bringing a new level of performance for systems buyers. The Pentium III processor is scaleable to two processors in a multiprocessor system and extends the power of the Pentium® II processor with performance headroom for business media, communication and internet capabilities. Systems based on Pentium III processors also include the latest features to simplify system management and lower the cost of ownership for large and small business environments. The Pentium III processor offers great performance for today’s and tomorrow’s applications.

### FC-PGA370 Package

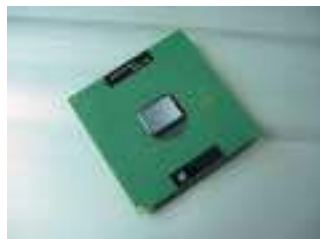

June 2001

Document Number: 245264-08



Information in this document is provided in connection with Intel® products. No license, express or implied, by estoppel or otherwise, to any intellectual property rights is granted by this document. Except as provided in Intel's Terms and Conditions of Sale for such products, Intel assumes no liability whatsoever, and Intel disclaims any express or implied warranty, relating to sale and/or use of Intel products including liability or warranties relating to fitness for a particular purpose, merchantability, or infringement of any patent, copyright or other intellectual property right. Intel products are not intended for use in medical, life saving, or life sustaining applications.

Intel may make changes to specifications and product descriptions at any time, without notice.

Designers must not rely on the absence or characteristics of any features or instructions marked "reserved" or "undefined." Intel reserves these for future definition and shall have no responsibility whatsoever for conflicts or incompatibilities arising from future changes to them.

The Pentium® III processor may contain design defects or errors known as errata which may cause the product to deviate from published specifications. Current characterized errata are available on request.

Contact your local Intel sales office or your distributor to obtain the latest specifications and before placing your product order.

Copies of documents which have an ordering number and are referenced in this document, or other Intel literature may be obtained by calling 1-800-548-4725 or by visiting Intel's website at <http://www.intel.com>.

Intel, Pentium II, Pentium III, Pentium Pro, Celeron and Intel387 are trademarks or registered trademarks of Intel Corporation or its subsidiaries in the United States and other countries.

\*Other names and brands may be claimed as the property of others.

Copyright © Intel Corporation, 2001

# Contents

<b>1.0</b>	<b>Introduction</b> .....	8
1.1	Terminology .....	9
1.1.1	Package and Processor Terminology .....	9
1.1.2	Processor Naming Convention .....	10
1.2	Related Documents .....	11
<b>2.0</b>	<b>Electrical Specifications</b> .....	13
2.1	Processor System Bus and $V_{REF}$ .....	13
2.2	Clock Control and Low Power States .....	14
2.2.1	Normal State—State 1 .....	15
2.2.2	AutoHALT Powerdown State—State 2 .....	15
2.2.3	Stop-Grant State—State 3 .....	16
2.2.4	HALT/Grant Snoop State—State 4 .....	16
2.2.5	Sleep State—State 5 .....	16
2.2.6	Deep Sleep State—State 6 .....	17
2.2.7	Clock Control .....	17
2.3	Power and Ground Pins .....	17
2.3.1	Phase Lock Loop (PLL) Power .....	18
2.4	Decoupling Guidelines .....	19
2.4.1	Processor $V_{CC_{CORE}}$ and AGTL+ (AGTL) Decoupling .....	19
2.5	Processor System Bus Clock and Processor Clocking .....	19
2.5.1	Mixing Processors of Different Frequencies .....	20
2.6	Voltage Identification .....	20
2.7	Processor System Bus Unused Pins .....	22
2.8	Processor System Bus Signal Groups .....	22
2.8.1	Asynchronous vs. Synchronous for System Bus Signals .....	24
2.8.2	System Bus Frequency Select Signals (BSEL[1:0]) .....	25
2.9	Maximum Ratings .....	26
2.10	Processor DC Specifications .....	27
2.10.1	ICC Slew Rate Specifications .....	33
2.11	AGTL / AGTL+ System Bus Specifications .....	36
2.12	System Bus AC Specifications .....	37
2.12.1	I/O Buffer Model .....	37
<b>3.0</b>	<b>Signal Quality Specifications</b> .....	46
3.1	BCLK/BCLK# and PICCLK Signal Quality Specifications and Measurement Guidelines .....	46
3.2	AGTL+ / AGTL Signal Quality Specifications and Measurement Guidelines .....	47
3.3	AGTL+ Signal Quality Specifications and Measurement Guidelines .....	48
3.3.1	Overshoot/Undershoot Guidelines .....	48
3.3.2	Overshoot/Undershoot Magnitude .....	49
3.3.3	Overshoot/Undershoot Pulse Duration .....	49
3.3.4	Activity Factor .....	49
3.3.5	Reading Overshoot/Undershoot Specification Tables .....	50
3.3.6	Determining if a System Meets the Overshoot/Undershoot Specifications .....	51
3.4	Non-AGTL+ (Non-AGTL) Signal Quality Specifications and Measurement	



	Guidelines .....	54
	3.4.1 Overshoot/Undershoot Guidelines .....	54
	3.4.2 Ringback Specification .....	55
	3.4.3 Settling Limit Guideline .....	55
<b>4.0</b>	<b>Thermal Specifications and Design Considerations .....</b>	<b>56</b>
4.1	Thermal Specifications .....	56
4.2	Processor Die Area .....	57
4.3	Thermal Diode.....	58
<b>5.0</b>	<b>Mechanical Specifications .....</b>	<b>60</b>
5.1	FC-PGA Mechanical Specifications .....	60
	5.1.1 FC-PGA2 Mechanical Specifications .....	63
5.2	Processor Markings .....	65
	5.2.1 Processor Markings for FC-PGA2.....	65
5.3	Recommended Mechanical Keep-Out Zones .....	66
5.4	Processor Signal Listing.....	67
<b>6.0</b>	<b>Boxed Processor Specifications .....</b>	<b>80</b>
6.1	Mechanical Specifications for the Boxed Intel® Pentium® III Processor.....	80
	6.1.1 Boxed Processor Thermal Cooling Solution Dimensions.....	80
	6.1.2 Boxed Processor Heatsink Weight.....	82
	6.1.3 Boxed Processor Thermal Cooling Solution Clip .....	82
6.2	Thermal Specifications.....	82
	6.2.1 Boxed Processor Cooling Requirements .....	82
6.3	Electrical Requirements for the Boxed Intel® Pentium® III Processor.....	83
	6.3.1 Fan Heatsink Power Supply .....	83
<b>7.0</b>	<b>Processor Signal Description .....</b>	<b>85</b>
7.1	Alphabetical Signals Reference .....	85
7.2	Signal Summaries .....	92

## Figures

1	Second Level (L2) Cache Implementation .....	8
2	AGTL+/AGTL Bus Topology in a Uniprocessor Configuration .....	14
3	AGTL+/AGTL Bus Topology in a Dual-Processor Configuration .....	14
4	Stop Clock State Machine .....	15
5	Processor V <sub>CC</sub> CMOS Package Routing .....	18
6	Differential Clocking Example .....	20
7	BSEL[1:0] Example for a 100/133 MHz or 100 MHz Only System Design .....	25
8	Slew Rate (23A Load Step).....	33
9	Generic Clock Waveform .....	41
10	BCLK, PICCLK, and TCK Generic Clock Waveform.....	42
11	System Bus Valid Delay Timings .....	42
12	System Bus Setup and Hold Timings.....	43
13	System Bus Reset and Configuration Timings.....	43
14	Platform Power-On Sequence Timings .....	44
15	Power-On Reset and Configuration Timings.....	45
16	BCLK, PICCLK Generic Clock Waveform at the Processor Pins.....	47
17	Low to High AGTL+ Receiver Ringback Tolerance.....	48
18	Maximum Acceptable AGTL+ Overshoot/Undershoot Waveform.....	53
19	Maximum Acceptable AGTL Overshoot/Undershoot Waveform.....	53
20	Non-AGTL+ (Non-AGTL) Overshoot/Undershoot, Settling Limit, and Ringback 1 .....	54
21	Processor Functional Die Layout for FC-PGA.....	58
22	FC-PGA and FC-PGA2 Package Types .....	60
23	Package Dimensions.....	61
24	Package Dimensions for FC-PGA2.....	63
25	FC-PGA2 Flatness Specification.....	64
26	Top Side Processor Markings for FC-PGA (up to CPUID 0x686H) .....	65
27	Top Side Processor Markings for FC-PGA (for CPUID 0x68AH).....	65
28	Top Side Processor Markings for FC-PGA2 .....	66
29	Volumetric Keep-Out for FC-PGA and FC-PGA2.....	66
30	Component Keep-Out .....	67
31	Intel® Pentium® III Processor Pinout .....	68
32	Conceptual Boxed Intel® Pentium® III Processor for the PGA370 Socket.....	80
33	Dimensions of Mechanical Step Feature in Heatsink Base.....	81
34	Dimensions of Notches in Heatsink Base .....	82
35	Thermal Airspace Requirement for all Boxed Intel® Pentium® III Processor Fan Heatsinks in the PGA370 Socket .....	83
36	Boxed Processor Fan Heatsink Power Cable Connector Description.....	84
37	Motherboard Power Header Placement Relative to the Boxed Intel® Pentium® III Processor .....	84

## Tables

1	Processor Identification .....	10
2	Voltage Identification Definition .....	21
3	System Bus Signal Groups 1 .....	23
4	System Bus Signal Groups (AGTL)1 .....	23
5	Frequency Select Truth Table for BSEL[1:0] .....	26
6	Absolute Maximum Ratings .....	26
7	Voltage and Current Specifications .....	28
8	PL Slew Rate Data (23A) .....	33
9	AGTL / AGTL+ Signal Groups DC Specifications .....	34
10	Non-AGTL+ Signal Group DC Specifications .....	34
11	Non-AGTL Signal Group DC Specifications .....	35
12	Processor AGTL+ Bus Specifications .....	36
13	Processor AGTL Bus Specifications .....	36
14	System Bus AC Specifications (SET Clock) .....	37
15	System Bus Timing Specifications (Differential Clock) .....	38
16	System Bus AC Specifications (AGTL+ or AGTL Signal Group) .....	39
17	System Bus AC Specifications (CMOS Signal Group) .....	40
18	System Bus AC Specifications (Reset Conditions) .....	40
19	System Bus AC Specifications (APIC Clock and APIC I/O) .....	40
20	Platform Power-On Timings .....	40
21	BCLK/PICCLK Signal Quality Specifications for Simulation at the Processor Pins .....	46
22	BCLK/PICCLK Signal Quality Specifications for Simulation at the Processor Pins in a Differential Clock Platform for AGTL .....	46
23	AGTL+ Signal Groups Ringback Tolerance Specifications at the Processor Pins .....	47
24	Example Platform Information .....	50
25	100 MHz AGTL+ / AGTL Signal Group Overshoot/Undershoot Tolerance at Processor Pins .....	51
26	133 MHz AGTL+/AGTL Signal Group Overshoot/Undershoot Tolerance .....	52
27	33 MHz CMOS Signal Group Overshoot/Undershoot Tolerance at Processor Pins .....	52
28	Signal Ringback Specifications for Non-AGTL+ Signal Simulations at the Processor Pins .....	55
29	Signal Ringback Specifications for Non-AGTL Signal Simulations at the Processor Pins .....	55
30	Intel® Pentium® III Processor Thermal Design Power for the FC-PGA Package .. 56	
31	Intel® Pentium® III Processor for the FC-PGA2 Package Thermal Design Power .....	57
32	Processor Functional Die Layout for FC-PGA .....	58
33	Thermal Diode Parameters .....	59
34	Thermal Diode Interface .....	59
35	Intel® Pentium® III Processor Package Dimensions .....	61
36	Processor Die Loading Parameters for FC-PGA .....	62
37	Package Dimensions for Intel® Pentium® III Processor FC-PGA2 Package .....	63
38	Processor Case Loading Parameters for FC-PGA2 .....	64
39	Signal Listing in Order by Signal Name .....	69
40	Signal Listing in Order by Pin Number .....	74



41	Fan Heatsink Power and Signal Specifications.....	84
42	Signal Description .....	85
43	Output Signals.....	92
44	Input Signals.....	92
45	Input/Output Signals (Single Driver).....	94
46	Input/Output Signals (Multiple Driver) .....	94

## 1.0 Introduction

The Intel® Pentium® III processor for the PGA370 socket is the next member of the P6 family, in the Intel IA-32 processor line and hereafter will be referred to as the “Pentium III processor”, or simply “the processor”. The processor uses the same core and offers the same performance as the Pentium III processor for the SC242 connector, but utilizes a package technology called flip-chip pin grid array, or FC-PGA. This package utilizes the same 370-pin zero insertion force socket (PGA370) used by the Intel® Celeron™ processor. Thermal solutions are attached directly to the back of the processor core package without the use of a thermal plate or heat spreader. As core frequencies increase, the need for better power dissipation arises, so an Integrated Heat Spreader (IHS) has been introduced at the higher frequencies near 1B GHz. The package with an IHS is called FC-PGA2.

The Pentium III processor, like its predecessors in the P6 family of processors, implements a Dynamic Execution microarchitecture—a unique combination of multiple branch prediction, data flow analysis, and speculative execution. This enables these processors to deliver higher performance than the Pentium processor, while maintaining binary compatibility with all previous Intel Architecture processors. The processor also executes Intel® MMX™ technology instructions for enhanced media and communication performance just as it’s predecessor, the Pentium III processor. Additionally, Pentium III processor executes Streaming SIMD (single-instruction, multiple data) Extensions for enhanced floating point and 3-D application performance. The concept of processor identification, via CPUID, is extended in the processor family with the addition of a processor serial number. Refer to the *Intel® Processor Serial Number* application note for more detailed information. The processor utilizes multiple low-power states such as AutoHALT, Stop-Grant, Sleep, and Deep Sleep to conserve power during idle times.

The processor includes an integrated on-die, 256-KB, 8-way set associative level-two (L2) cache. The L2 cache implements the new Advanced Transfer Cache Architecture with a 256-bit wide bus. The processor also includes a 16-KB level one (L1) instruction cache and 16-KB L1 data cache. These cache arrays run at the full speed of the processor core. As with the Pentium III processor for the SC242 connector, the Pentium III processor for the PGA370 socket has a dedicated L2 cache bus, thus maintaining the dual independent bus architecture to deliver high bus bandwidth and performance (see [Figure 1](#)). Memory is cacheable for 64 GB of addressable memory space, allowing significant headroom for desktop systems. Refer to the Specification Update document for this processor to determine the cacheability and cache configuration options for a specific processor. The Specification Update document can be requested at your nearest Intel sales office.

The processor utilizes the same multiprocessing system bus technology as the Pentium II processor. This allows for a higher level of performance for both uni-processor and two-way multiprocessor systems. The system bus uses a variant of GTL+ signaling technology called Assisted Gunning Transceiver Logic (AGTL+/AGTL) signaling technology.

**Figure 1. Second Level (L2) Cache Implementation**

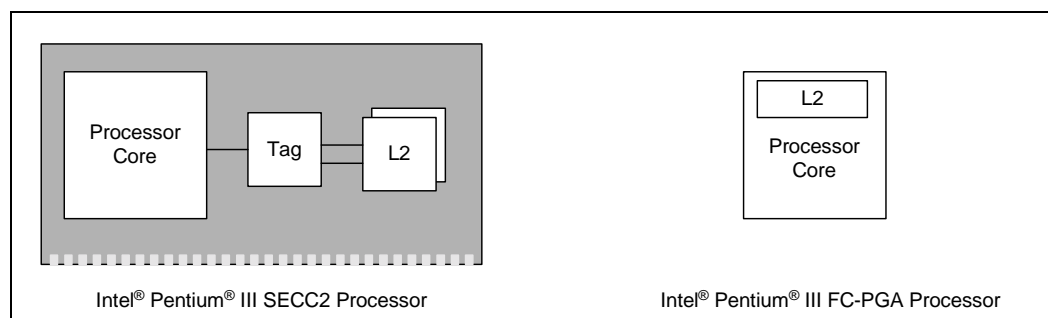



## 1.1 Terminology

In this document, a '#' symbol after a signal name refers to an active low signal. This means that a signal is in the active state (based on the name of the signal) when driven to a low level. For example, when FLUSH# is low, a flush has been requested. When NMI is high, a nonmaskable interrupt has occurred. In the case of signals where the name does not imply an active state but describes part of a binary sequence (such as *address* or *data*), the '#' symbol implies that the signal is inverted. For example, D[3:0] = 'HLHL' refers to a hex 'A', and D[3:0]# = 'LHLH' also refers to a hex 'A' (H= High logic level, L= Low logic level).

The term "system bus" refers to the interface between the processor, system core logic (a.k.a. the chipset components), and other bus agents.

### 1.1.1 Package and Processor Terminology

The following terms are used often in this document and are explained here for clarification:

- **Pentium III processor** - The entire product including all internal components.
- **PGA370 socket** - 370-pin Zero Insertion Force (ZIF) socket which a FC-PGA or PPGA packaged processor plugs into.
- **FC-PGA** - Flip Chip Pin Grid Array. The package technology used on Pentium III processors for the PGA370 socket.
- **FC-PGA2** - Flip Chip Pin Grid Array with an Integrated Heat Spreader (IHS). The package technology used on Pentium III processors for the PGA370 socket for increased power dissipation away from the die. The IHS covers the die and has a very low thermal resistance.
- **Integrated Heat Spreader (IHS)** - The IHS is a metal cover on the die and is an integral part of the CPU. The IHS promotes heat spreading away from the die backside to ease thermal constraints.
- **Advanced Transfer Cache (ATC)** - New L2 cache architecture unique to the 0.18 micron Pentium III processors. ATC consists of microarchitectural improvements that provide a higher data bandwidth interface into the processor core that is completely scaleable with the processor core frequency.
- **Keep-out zone** - The area on or near a FC-PGA packaged processor that system designs can not utilize.
- **Keep-in zone** - The area of a FC-PGA packaged processor that thermal solutions may utilize.
- **OLGA** - Organic Land Grid Array. The package technology for the core used in S.E.C.C. 2 processors that permits attachment of the heatsink directly to the die.
- **PPGA - Plastic Pin Grid Array.** The package technology used for Celeron processors that utilize the PGA370 socket.
- **Processor** - For this document, the term processor is the generic form of the Pentium III processor for the PGA370 socket in the FC-PGA package.
- **Processor core** - The processor's execution engine.
- **S.E.C.C.** - The processor package technology called "Single Edge Contact Cartridge". Used with Intel® Pentium® II processors.
- **S.E.C.C. 2** - The follow-on to S.E.C.C. processor package technology. This differs from its predecessor in that it has no extended thermal plate, thus reducing thermal resistance. Used with Pentium III processors and latest versions of the Pentium II processor.



- **SC242** - The 242-contact slot connector (previously referred to as slot 1 connector) that the S.E.C.C. and S.E.C.C. 2 plug into, just as the Intel® Pentium® Pro processor uses socket 8.

The cache and L2 cache are an industry designated names.

### 1.1.2 Processor Naming Convention

A letter(s) is added to certain processors (e.g., 600EB MHz) when the core frequency alone may not uniquely identify the processor. Below is a summary of what each letter means as well as a table listing all the available Pentium III processors for the PGA370 socket.

“B” — 133 MHz System Bus Frequency

“E” — Processor with “Advanced Transfer Cache” (CUID 068xh and greater)

**Table 1. Processor Identification**

Processor	Core Frequency (MHz)	System Bus Frequency (MHz)	L2 Cache Size (Kbytes)	L2 Cache Type <sup>2</sup>	CUID <sup>1</sup>
500E	500	100	256	ATC	068xh
533EB	533	133	256	ATC	068xh
550E	550	100	256	ATC	068xh
600E	600	100	256	ATC	068xh
600EB	600	133	256	ATC	068xh
650	650	100	256	ATC	068xh
667	667	133	256	ATC	068xh
700	700	100	256	ATC	068xh
733	733	133	256	ATC	068xh
750	750	100	256	ATC	068xh
800	800	100	256	ATC	068xh
800EB	800	133	256	ATC	068xh
850	850	100	256	ATC	068xh
866	866	133	256	ATC	068xh
900	900	100	256	ATC	068xh
933	933	133	256	ATC	068xh
1 GHz	1000	100	256	ATC	068xh
1B GHz	1000	133	256	ATC	068xh
1.10 GHz	1100	100	256	ATC	068xh
1.13 GHz	1133	133	256	ATC	068xh

**NOTES:**

1. Refer to the *Pentium® III Processor Specification Update* for the exact CUID for each processor.
2. ATC = Advanced Transfer Cache. ATC is an L2 Cache integrated on the same die as the processor core. With ATC, the interface between the processor core and L2 Cache is 256-bits wide, runs at the same frequency as the processor core and has enhanced buffering.



## 1.2 Related Documents

The reader of this specification should also be familiar with material and concepts presented in the following documents <sup>1,2</sup>:

Document	Intel Document Number
AP-485, <i>Intel® Processor Identification and the CPUID Instruction</i>	241618
AP-585, <i>Pentium® II Processor GTL+ Guidelines</i>	243330
AP-589, <i>Design for EMI</i>	243334
AP-905, <i>Pentium® III Processor Thermal Design Guidelines</i>	245087
AP-907, <i>Pentium® III Processor Power Distribution Guidelines</i>	245085
AP-909, <i>Intel® Processor Serial Number</i>	245125
<i>Intel® Architecture Software Developer's Manual</i>	243193
Volume I: Basic Architecture	243190
Volume II: Instruction Set Reference	243191
Volume III: System Programming Guide	243192
<i>P6 Family of Processors Hardware Developer's Manual</i>	244001
<i>Pentium® II Processor Developer's Manual</i>	243502
Pentium® III Processor Datasheet for SECC2	244452
Pentium® III Processor Datasheet for PGA370	245264
Pentium® III Processor Specification Update	244453
<i>Intel® Celeron™ Processor Datasheet</i>	243658
<i>Intel® Celeron™ Processor Specification Update</i>	243748
<i>370-Pin Socket (PGA370) Design Guidelines</i>	244410
<i>PGA370 Heat Sink Cooling in MicroATX Chassis</i>	245025
<i>Intel® 810E Chipset Platform Design Guide</i>	290675
<i>Intel® 815 B-step Chipset Platform Design Guide</i> <sup>3</sup>	
<i>Intel® 815E Chipset Platform Design Guide</i>	298234
<i>Intel® 820 Chipset Platform Design Guide</i>	290631
<i>Intel® 840 Chipset Platform Design Guide</i>	298021
<i>CK98 Clock Synthesizer/Driver Design Guidelines</i>	245338
<i>Intel® 810E Chipset Clock Synthesizer/Driver Specification</i> <sup>3</sup>	
<i>VRM 8.4 DC-DC Converter Design Guidelines</i>	245335
<i>Pentium III Processor for the PGA370 Socket I/O Buffer Models, XTK/XNS* Format</i> <sup>3</sup>	
<i>Pentium® Pro Processor BIOS Writer's Guide</i> <sup>3</sup>	
<i>Extensions to the Pentium® Pro Processor BIOS Writer's Guide rev. 3.7</i> <sup>3</sup>	
<i>Pentium® III Thermal/Mechanical Solution Functional Guidelines</i>	245241
<i>Intel® Pentium® III Processor in the FC-PGA2 Package Thermal Design Guide</i>	249660



**NOTES:**

1. Unless otherwise noted, this reference material can be found on the Intel Developer's Website located at <http://developer.intel.com>.
2. For a complete listing of Pentium III processor reference material, please refer to the Intel Developer's Website at <http://developer.intel.com/design/PentiumIII/>.
3. This material is available through an Intel field sales representative.

## 2.0 Electrical Specifications

---

### 2.1 Processor System Bus and $V_{REF}$

The Pentium III processor signals use a variation of the low voltage Gunning Transceiver Logic (GTL) signaling technology.

The Pentium Pro processor system bus specification is similar to the GTL specification, but was enhanced to provide larger noise margins and reduced ringing. The improvements are accomplished by increasing the termination voltage level and controlling the edge rates. This specification is different from the GTL specification, and is referred to as GTL+. For more information on GTL+ specifications, see the GTL+ buffer specification in the *Intel® Pentium® II Processor Developer's Manual*.

Current P6 family processors vary from the Pentium Pro processor in their output buffer implementation. The buffers that drive the system bus signals on the Celeron, Pentium II, and Pentium III processors are actively driven to  $V_{TT}$  for one clock cycle after the low to high transition to improve rise times. These signals should still be considered open-drain and require termination to a supply that provides the high signal level. Because this specification is different from the standard GTL+ specification, it is referred to as AGTL+, or Assisted GTL+ in this and other documentation. AGTL+ logic and GTL+ logic are compatible with each other and may both be used on the same system bus. For more information on AGTL+ routing, see the appropriate platform design guide.

Note that some Pentium III processors with CPUID 068xh support the AGTL specification in addition to the AGTL+ specification. AGTL logic and AGTL+ logic are not compatible with each other due to differences with the signal switching levels. Processors that do not support the AGTL specification cannot be installed into platforms where the chipset only supports the AGTL signal levels. For more information on AGTL or AGTL+ routing, please refer to the appropriate platform design guide.

Both AGTL and AGTL+ inputs use differential receivers which require a reference signal ( $V_{REF}$ ).  $V_{REF}$  is used by the receivers to determine if a signal is a logical 0 or a logical 1, and is supplied by the motherboard to the PGA370 socket for the processor core. Local  $V_{REF}$  copies should also be generated on the motherboard for all other devices on the AGTL+ (AGTL) system bus. Termination (usually a resistor at each end of the signal trace) is used to pull the bus up to the high voltage level and to control reflections on the transmission line. The processor contains on-die termination resistors that provide termination for one end of the bus, except for RESET#. These specifications assume another resistor at the end of each signal trace to ensure adequate signal quality for the AGTL+ (AGTL) signals and provide backwards compatibility for the Celeron processor; see [Table 12](#) for the bus termination voltage specifications for AGTL+. Refer to the *Intel® Pentium® II Processor Developer's Manual* for the AGTL+ bus specification. Solutions exist for single-ended termination as well, though this implementation changes system design and eliminate backwards compatibility for Celeron processors in the PPGA package. Single-ended termination designs must still provide an AGTL+ (AGTL) termination resistor on the motherboard for the RESET# signal. [Figure 2](#) is a schematic representation of the AGTL+ (AGTL) bus topology for the Pentium III processors in the PGA370 socket. [Figure 3](#) is a schematic representation of the AGTL+/AGTL bus topology in a dual-processor configuration with Pentium III processors in the PGA370 socket.

Both AGTL+ and AGTL bus depend on incident wave switching. Therefore, timing calculations for AGTL+ or AGTL signals are based on flight time as opposed to capacitive deratings. Analog signal simulation of the system bus including trace lengths is highly recommended when designing a

system with a heavily loaded AGTL+ bus, especially for systems using a single set of termination resistors (i.e., those on the processor die). Such designs will not match the solution space allowed for by installation of termination resistors on the baseboard.

**Figure 2. AGTL+/AGTL Bus Topology in a Uniprocessor Configuration**

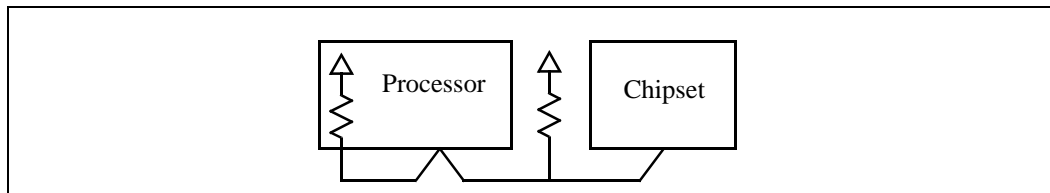

**Figure 3. AGTL+/AGTL Bus Topology in a Dual-Processor Configuration**

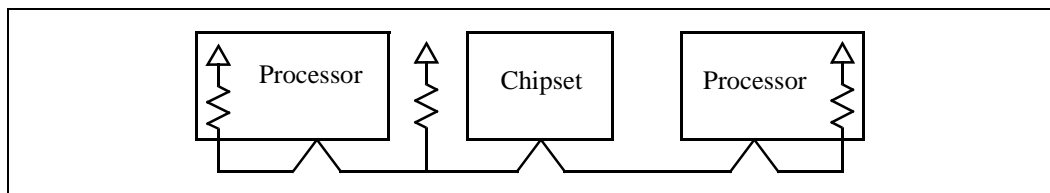

## 2.2 Clock Control and Low Power States

Processors allow the use of AutoHALT, Stop-Grant, Sleep, and Deep Sleep states to reduce power consumption by stopping the clock to internal sections of the processor, depending on each particular state. See [Figure 4](#) for a visual representation of the processor low-power states.

Figure 4. Stop Clock State Machine

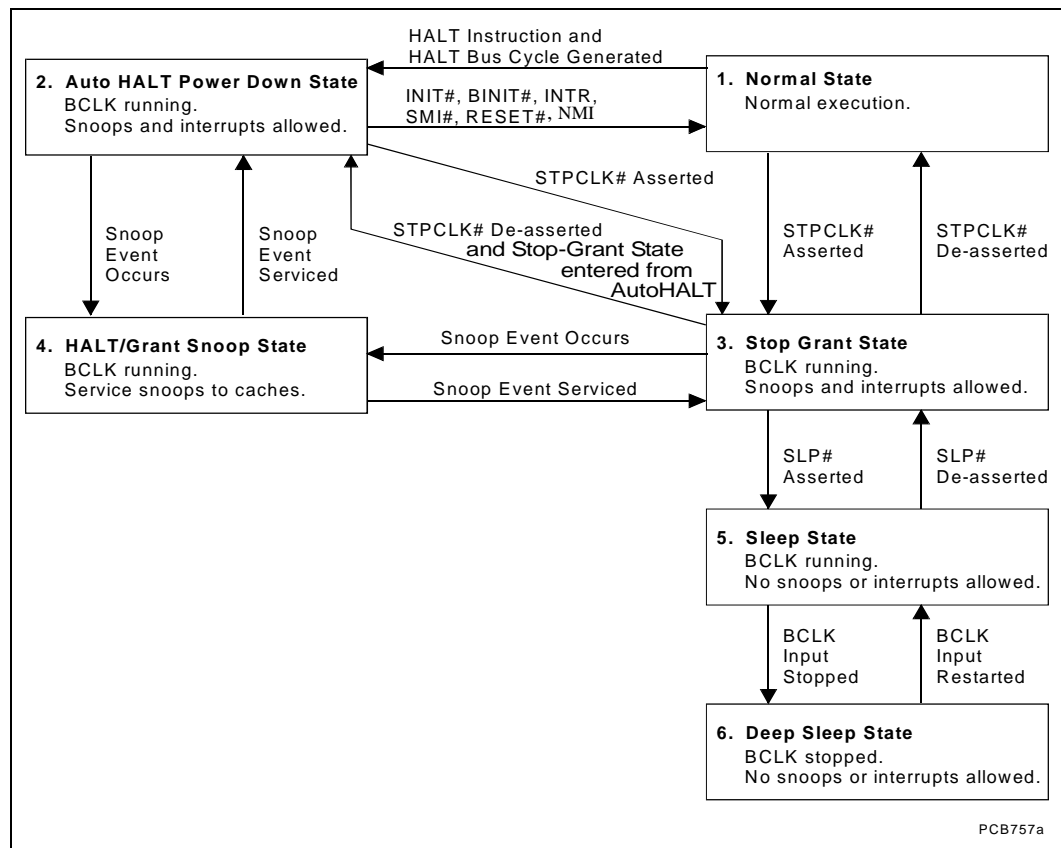

For the processor to fully realize the low current consumption of the Stop-Grant, Sleep and Deep Sleep states, a Model Specific Register (MSR) bit must be set. For the MSR at 02AH (Hex), bit 26 must be set to a '1' (this is the power on default setting) for the processor to stop all internal clocks during these modes. For more information, see the *Intel Architecture Software Developer's Manual, Volume 3: System Programming Guide* located on the developer.intel.com website.

### 2.2.1 Normal State—State 1

This is the normal operating state for the processor.

### 2.2.2 AutoHALT Powerdown State—State 2

AutoHALT is a low power state entered when the processor executes the HALT instruction. The processor transitions to the Normal state upon the occurrence of SMI#, INIT#, or LINT[1:0] (NMI, INTR). RESET# causes the processor to immediately initialize itself.

The return from a System Management Interrupt (SMI) handler can be to either Normal Mode or the AutoHALT Power Down state. See the *Intel Architecture Software Developer's Manual, Volume III: System Programmer's Guide* for more information.

FLUSH# is serviced during the AutoHALT state, and the processor will return to the AutoHALT state.

The system can generate a STPCLK# while the processor is in the AutoHALT Power Down state. When the system deasserts the STPCLK# interrupt, the processor returns execution to the HALT state.

### 2.2.3 Stop-Grant State—State 3

The Stop-Grant state on the processor is entered when the STPCLK# signal is asserted.

Since the AGTL+ signal pins receive power from the system bus, these pins should not be driven (allowing the level to return to VTT) for minimum power drawn by the termination resistors in this state. In addition, all other input pins on the system bus should be driven to the inactive state.

BINIT# and FLUSH# are not serviced during the Stop-Grant state.

RESET# causes the processor to immediately initialize itself, but the processor stays in Stop-Grant state. A transition back to the Normal state occurs with the deassertion of the STPCLK# signal.

A transition to the HALT/Grant Snoop state occurs when the processor detects a snoop on the system bus (see [Section 2.2.4](#)). A transition to the Sleep state (see [Section 2.2.5](#)) occurs with the assertion of the SLP# signal.

While in Stop-Grant State, SMI#, INIT#, and LINT[1:0] are latched by the processor, and only serviced when the processor returns to the Normal state. Only one occurrence of each event is recognized and serviced upon return to the Normal state.

### 2.2.4 HALT/Grant Snoop State—State 4

The processor responds to snoop transactions on the system bus while in Stop-Grant state or in AutoHALT Power Down state. During a snoop transaction, the processor enters the HALT/Grant Snoop state. The processor stays in this state until the snoop on the system bus has been serviced (whether by the processor or another agent on the system bus). After the snoop is serviced, the processor returns to the Stop-Grant state or AutoHALT Power Down state, as appropriate.

### 2.2.5 Sleep State—State 5

The Sleep state is a very low power state in which the processor maintains its context, maintains the phase-locked loop (PLL), and has stopped all internal clocks. The Sleep state can only be entered from the Stop-Grant state. Once in the Stop-Grant state, the SLP# pin can be asserted, causing the processor to enter the Sleep state. The SLP# pin is not recognized in the Normal or AutoHALT states.

Snoop events that occur while in Sleep state or during a transition into or out of Sleep state will cause unpredictable behavior.

In the Sleep state, the processor is incapable of responding to snoop transactions or latching interrupt signals. No transitions or assertions of signals (with the exception of SLP# or RESET#) are allowed on the system bus while the processor is in Sleep state. Any transition on an input signal before the processor has returned to Stop-Grant state will result in unpredictable behavior.

If RESET# is driven active while the processor is in the Sleep state, and held active as specified in the RESET# pin specification, then the processor will reset itself, ignoring the transition through Stop-Grant State. If RESET# is driven active while the processor is in the Sleep State, the SLP# and STPCLK# signals should be deasserted immediately after RESET# is asserted to ensure the processor correctly executes the reset sequence.



While in the Sleep state, the processor is capable of entering its lowest power state, the Deep Sleep state, by stopping the BCLK input (see Section 2.2.6). Once in the Sleep or Deep Sleep states, the SLP# pin can be deasserted if another asynchronous system bus event occurs. The SLP# pin has a minimum assertion of one BCLK period.

## 2.2.6 Deep Sleep State—State 6

The Deep Sleep state is the lowest power state the processor can enter while maintaining context. The Deep Sleep state is entered by stopping the BCLK<sup>1</sup> input (after the Sleep state was entered from the assertion of the SLP# pin). The processor is in Deep Sleep state immediately after BCLK is stopped. It is recommended that the BCLK<sup>1</sup> input be held low during the Deep Sleep State. Stopping of the BCLK<sup>1</sup> input lowers the overall current consumption to leakage levels.

To re-enter the Sleep state, the BCLK input must be restarted. A period of 1 ms (to allow for PLL stabilization) must occur before the processor can be considered to be in the Sleep state. Once in the Sleep state, the SLP# pin can be deasserted to re-enter the Stop-Grant state.

While in Deep Sleep state, the processor is incapable of responding to snoop transactions or latching interrupt signals. No transitions or assertions of signals are allowed on the system bus while the processor is in Deep Sleep state. Any transition on an input signal before the processor has returned to Stop-Grant state will result in unpredictable behavior.

## 2.2.7 Clock Control

BCLK<sup>2</sup> provides the clock signal for the processor and on die L2 cache. During AutoHALT Power Down and Stop-Grant states, the processor will process a system bus snoop. The processor does not stop the clock to the L2 cache during AutoHALT Power Down or Stop-Grant states. Entrance into the Halt/Grant Snoop state allows the L2 cache to be snooped, similar to the Normal state.

When the processor is in Sleep and Deep Sleep states, it does not respond to interrupts or snoop transactions. During the Sleep state, the internal clock to the L2 cache is not stopped. During the Deep Sleep state, the internal clock to the L2 cache is stopped. The internal clock to the L2 cache is restarted only after the internal clocking mechanism for the processor is stable (i.e., the processor has re-entered Sleep state).

PICCLK should not be removed during the AutoHALT Power Down or Stop-Grant states. PICCLK can be removed during the Sleep or Deep Sleep states. When transitioning from the Deep Sleep state to the Sleep state, PICCLK must be restarted with BCLK.<sup>2</sup>

## 2.3 Power and Ground Pins

The operating voltage of the Pentium III processor for the PGA370 socket is the same for the core and the L2 cache; VCC<sub>CORE</sub>. There are four pins defined on the package for voltage identification (VID). These pins specify the voltage required by the processor core. These have been added to cleanly support voltage specification variations on current and future processors.

For clean on-chip power and voltage reference distribution, the Pentium III processors in the PGA370 socket have 75 VCC<sub>CORE</sub>, 8 V<sub>REF</sub> (7 for AGTL platforms), 15 VTT, and 77 VSS (ground) inputs. VCC<sub>CORE</sub> inputs supply the processor core, including the on-die L2 cache. VTT inputs

---

1. For processors using AGTL level bus with differential clocking, the deep sleep state is entered by stopping BCLK and BCLK# input.  
2. For processors using AGTL level bus with differential clocking this would also include the BCLK# signal as well.

(1.5 V/1.25 V) are used to provide an AGTL+/AGTL termination voltage to the processor, and the  $V_{REF}$  inputs are used as the AGTL+/AGTL reference voltage for the processor. Note that not all VTT inputs must be connected to the VTT supply. Refer to [Section 5.4](#) for more details.

On the motherboard, all  $VCC_{CORE}$  pins must be connected to a voltage island (an island is a portion of a power plane that has been divided, or an entire plane). In addition, the motherboard must implement the VTT pins as a voltage island or large trace. Similarly, all GND pins must be connected to a system ground plane.

Three additional power related pins exist on a processors utilizing the PGA370 socket. They are  $VCC_{1.5}$ ,  $VCC_{2.5}$  and  $VCC_{CMOS}$ .

The  $VCC_{CMOS}$  pin provides the CMOS voltage for the pull-up resistors required on the system platform. A 2.5 V source must be provided to the  $VCC_{2.5}$  pin and a 1.5 V source must be provided to the  $VCC_{1.5}$  pin. The source for  $VCC_{1.5}$  must be the same as the one supplying VTT. The processor routes the compatible CMOS voltage source (1.5 V or 2.5 V) through the package and out to the  $VCC_{CMOS}$  output pin. Processors based on 0.25 micron technology (e.g., the Celeron processor) utilize 2.5 V CMOS buffers. Processors based on 0.18 micron technology (e.g., the Pentium III processor for the PGA370 socket) utilize 1.5 V CMOS buffers. The signal  $V_{COREDET}$  can be used by hardware on the motherboard to detect which CMOS voltage the processor requires. A  $V_{COREDET}$  connected to VSS within the processor indicates a 1.5 V requirement on  $VCC_{CMOS}$ . Refer to [Figure 5](#).

Each power signal must meet the specifications stated in [Table 7 on page 28](#).

**Figure 5. Processor  $VCC_{CMOS}$  Package Routing**

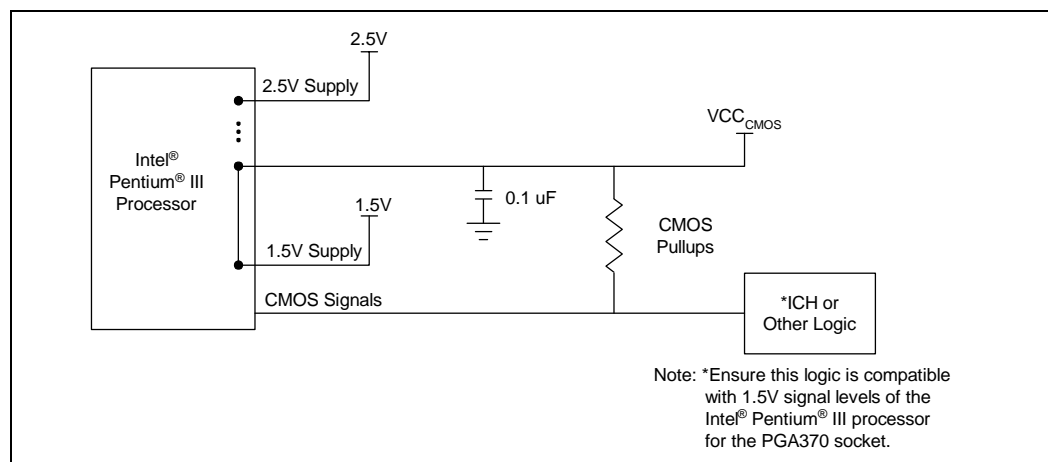

### 2.3.1 Phase Lock Loop (PLL) Power

It is highly critical that phase lock loop power delivery to the processor meets Intel's requirements. A low pass filter is required for power delivery to pins PLL1 and PLL2. This serves as an isolated, decoupled power source for the internal PLL. Please refer to the Phase Lock Loop Power section in the **appropriate platform design guide** for the recommended filter specifications.

## 2.4 Decoupling Guidelines

Due to the large number of transistors and high internal clock speeds, the processor is capable of generating large average current swings between low and full power states. The fluctuations can cause voltages on power planes to sag below their nominal values if bulk decoupling is not adequate. Care must be taken in the board design to ensure that the voltage provided to the processor remains within the specifications listed in [Table 7](#). Failure to do so can result in timing violations (in the event of a voltage sag) or a reduced lifetime of the component (in the event of a voltage overshoot). **Unlike SC242 based designs, motherboards utilizing the PGA370 socket must provide high frequency decoupling capacitors on all power planes for the processor.**

### 2.4.1 Processor VCC<sub>CORE</sub> and AGTL+ (AGTL) Decoupling

The regulator for the VCC<sub>CORE</sub> input must be capable of delivering the  $dI_{CC_{CORE}}/dt$  (defined in [Table 7](#)) while maintaining the required tolerances (also defined in [Table 7](#)). Failure to meet these specifications can result in timing violations (during VCC<sub>CORE</sub> sag) or a reduced lifetime of the component (during VCC<sub>CORE</sub> overshoot).

The processor requires both high frequency and bulk decoupling on the system motherboard for proper AGTL+ (AGTL) bus operation. See the AGTL+ buffer specification in the *Intel® Pentium® II Processor Developer's Manual* for more information. Also, refer to the appropriate platform design guide for recommended capacitor component placement. The minimum recommendation for the processor decoupling is listed below. All capacitors should be placed within the PGA370 socket cavity and mounted on the primary side of the motherboard. The capacitors are arranged to minimize the overall inductance between the VCC<sub>CORE</sub> and V<sub>SS</sub> power pins.

1. VCC<sub>CORE</sub> decoupling - 4.7  $\mu$ F capacitors in a 1206 package.
2. V<sub>TT</sub> decoupling - 0.1  $\mu$ F capacitors in 0603 package.
3. V<sub>REF</sub> decoupling - 0.1  $\mu$ F and 0.001  $\mu$ F capacitors in 0603 package placed near the V<sub>REF</sub> pins.

For additional decoupling requirements, please refer to the appropriate platform design guide for recommended capacitor component value, quantity and placement.

## 2.5 Processor System Bus Clock and Processor Clocking

The BCLK input directly controls the operating speed of the system bus interface. All AGTL+/AGTL system bus timing parameters are specified with respect to the rising edge of the BCLK input.

The Coppermine-T processor will implement an auto-detect mechanism that will let the processor use either single-ended or differential signaling for the system bus and processor clocking. The processor checks to see if the signal on pin Y33 is toggling. If this signal is toggling then the processor operates in differential mode. Refer to [Figure 6](#) for a differential clocking example. Resistor values and clock topology are listed in the appropriate platform design guide for a differential implementation.

**Note:** References to BCLK throughout this document will also imply to its complement signal, BCLK#, in differential implementations and when noted otherwise.

For a differential clock input, all AGTL system bus timing parameters are specified with respect to the crossing point of the rising edge of the BCLK input and the falling edge of the BCLK# input. See the *P6 Family of Processors Hardware Developer's Manual* for further details.

**Note:** For differential clocking, the reference voltage of the BCLK in the *P6 Family of Processors Hardware Developer's Manual* is re-defined as the crossing point of the BCLK and the BCLK# inputs.

**Figure 6. Differential Clocking Example**

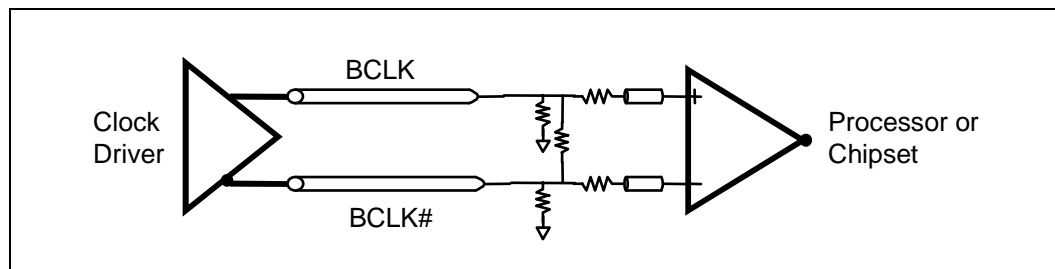

### 2.5.1 Mixing Processors of Different Frequencies

In two-way MP (multi-processor) systems, mixing processors of different internal clock frequencies is not supported and has not been validated. Pentium III processors do not support a variable multiplier ratio; therefore, adjusting the ratio setting to a common clock frequency is not valid. However, mixing processors of the same frequency but of different steppings is supported. Details on support for mixed steppings is provided in the *Pentium® III Processor Specification Update*.

**Note:** Not all Pentium III processors for the PGA370 socket are validated for use in dual processor (DP) systems. Refer to the *Pentium® III Processor Specification Update* to determine which processors are DP capable.

## 2.6 Voltage Identification

There are four voltage identification pins on the PGA370 socket. These pins can be used to support automatic selection of  $V_{CC_{CORE}}$  voltages. These pins are not signals, but are either an open circuit or a short circuit to VSS on the processor. The combination of opens and shorts defines the voltage required by the processor core. The VID pins are needed to cleanly support voltage specification variations on current and future processors. VID[3:0] are defined in [Table 2](#). A '1' in this table refers to an open pin and a '0' refers to a short to ground. The voltage regulator or VRM must supply the voltage that is requested or disable itself.

To ensure a system is ready for current and future processors, the range of values in **bold** in [Table 2](#) should be supported. A smaller range will risk the ability of the system to migrate to a higher performance processor and/or maintain compatibility with current processors.

**Table 2. Voltage Identification Definition** <sup>1, 2</sup>

VID3	VID2	VID1	VID0	V <sub>CC</sub> CORE
1	1	1	1	<b>1.30</b>
1	1	1	0	<b>1.35</b>
1	1	0	1	<b>1.40</b>
1	1	0	0	<b>1.45</b>
1	0	1	1	<b>1.50</b>
1	0	1	0	<b>1.55</b>
1	0	0	1	<b>1.60</b> <sup>3</sup>
1	0	0	0	<b>1.65</b> <sup>3</sup>
0	1	1	1	<b>1.70</b> <sup>3</sup>
0	1	1	0	<b>1.75</b> <sup>3</sup>
0	1	0	1	<b>1.80</b> <sup>3</sup>
0	1	0	0	<b>1.85</b> <sup>3</sup>
0	0	1	1	<b>1.90</b> <sup>3</sup>
0	0	1	0	<b>1.95</b> <sup>3</sup>
0	0	0	1	<b>2.00</b> <sup>3</sup>
0	0	0	0	<b>2.05</b> <sup>3</sup>
1	1	1	1	<b>No Core</b>

**NOTES:**

- 0 = Processor pin connected to VSS.
- 1 = Open on processor; may be pulled up to TTL V<sub>IH</sub> on baseboard.
- To ensure a system is ready for the Pentium III and Celeron processors, the values in **BOLD** in Table 2 should be supported.

Note that the ‘1111’ (all opens) ID can be used to detect the absence of a processor core in a given socket as long as the power supply used does not affect these lines. Detection logic and pull-ups should not affect VID inputs at the power source (see Section 7.0).

The VID pins should be pulled up to a TTL-compatible level with external resistors to the power source of the regulator only if required by the regulator or external logic monitoring the VID[3:0] signals. The power source chosen must be guaranteed to be stable whenever the supply to the voltage regulator is stable. This will prevent the possibility of the processor supply going above the specified V<sub>CC</sub>CORE in the event of a failure in the supply for the VID lines. In the case of a DC-to-DC converter, this can be accomplished by using the input voltage to the converter for the VID line pull-ups. A resistor of greater than or equal to 10 kΩ may be used to connect the VID signals to the converter input. Note that no changes have been made to the physical connector or pin definitions between the Intel-enabled VRM 8.2 and VRM 8.4 specifications.

**Note:** VRM 8.5 specification uses five VID pin assignments VID[3:0, 25mV] and it is not compatible with VRM 8.4. Some Pentium III processors with CPUID 068xh are capable of supporting both VRM 8.4 and VRM 8.5 specifications. Please refer to the *Pentium III Specification Update* for a listing of processors that support both VRM specifications.

## 2.7 Processor System Bus Unused Pins

All RESERVED pins must remain unconnected unless specifically noted. Connection of these pins to  $V_{CC_{CORE}}$ ,  $V_{REF}$ ,  $V_{SS}$ ,  $V_{TT}$ , or to any other signal (including each other) can result in component malfunction or incompatibility with future processors. See [Section 5.4](#) for a pin listing of the processor and the location of each RESERVED pin.

PICCLK must be driven with a valid clock input and the PICD[1:0] signals must be pulled-up to  $V_{CC_{CMOS}}$  even when the APIC will not be used. A separate pull-up resistor must be provided for each PICD signal.

For reliable operation, always connect unused inputs or bidirectional signals to their deasserted signal level. The pull-up or pull-down resistor values are system dependent and should be chosen such that the logic high ( $V_{IH}$ ) and logic low ( $V_{IL}$ ) requirements are met. See [Table 10](#) and [Table 11](#) for DC specifications of non-AGTL+/AGTL signals.

Unused AGTL+ (or AGTL) inputs must be properly terminated to  $V_{TT}$  on PGA370 socket motherboards which support the Celeron and the Pentium III processors. For designs that intend to only support the Pentium III processor, unused AGTL+ inputs will be terminated by the processor's on-die termination resistors and thus do not need to be terminated on the motherboard. However, RESET# must always be terminated on the motherboard as the Pentium III processor for the PGA370 socket does not provide on-die termination of this input.

For unused CMOS inputs, active low signals should be connected through a pull-up resistor to  $V_{CC_{CMOS}}$  and meet  $V_{IH}$  requirements. Unused active high CMOS inputs should be connected through a pull-down resistor to ground ( $V_{SS}$ ) and meet  $V_{IL}$  requirements. Unused CMOS outputs can be left unconnected. A resistor must be used when tying bidirectional signals to power or ground. When tying any signal to power or ground, a resistor will also allow for system testability.

## 2.8 Processor System Bus Signal Groups

To simplify the following discussion, the processor system bus signals have been combined into groups by buffer type. All P6 family processor system bus outputs are open drain and require a high-level source provided termination resistors. However, the Pentium III processor for the PGA370 socket includes on-die termination. **Motherboard designs that also support Celeron processors in the PPGA package will need to provide AGTL+ termination on the system motherboard as well. Platform designs that support dual processor configurations will need to provide AGTL+ termination, via a termination package, in any socket not populated with a processor. Please refer to the *Pentium III Processor Specification Update* for a complete listing of the processors that support the AGTL and AGTL+ specifications. Note that AGTL platforms do not support the Celeron processor in the PPGA package.**

Both AGTL+ and AGTL input signals have differential input buffers which use  $V_{REF}$  as a reference signal. AGTL+ output signals require termination to 1.5 V while AGTL output signals require termination to 1.25 V. In this document, the term “AGTL+ Input” refers to the AGTL+ input group as well as the AGTL+ I/O group when receiving. Similarly, “AGTL+ Output” refers to the AGTL+ output group as well as the AGTL+ I/O group when driving.

The PWRGOOD, BCLK, and PICCLK inputs can each be driven from ground to 2.5 V. Other CMOS inputs (A20M#, IGNNE#, INIT#, LINT0/INTR, LINT1/NMI, PREQ#, SMI, SLP#, and STPCLK#) are only 1.5 V tolerant and must be pulled up to  $V_{CC_{CMOS}}$ . The CMOS, APIC, and TAP outputs are open drain and must be pulled high to  $V_{CC_{CMOS}}$ . This ensures correct operation for current Pentium III and Celeron processors.

The groups and the signals contained within each group are shown in Table 3 and Table 4. Refer to Section 7.0 for a description of these signals.

**Table 3. System Bus Signal Groups <sup>1</sup>**

Group Name	Signals
AGTL+ Input	BPRI#, BR1# <sup>7</sup> , DEFER#, RESET# <sup>6</sup> , RESET2#, RS[2:0]#, RSP#, TRDY#
AGTL+ Output	PRDY#
AGTL+ I/O	A[35:3]#, ADS#, AERR#, AP[1:0]#, BERR#, BINIT#, BNR#, BP[3:2]#, BPM[1:0]#, BR0# <sup>2</sup> , D[63:0]#, DBSY#, DEP[7:0]#, DRDY#, HIT#, HITM#, LOCK#, REQ[4:0]#, RP#
CMOS Input <sup>3</sup>	A20M#, FLUSH#, IGNNE#, INIT#, LINT0/INTR, LINT1/NMI, PREQ#, SLP#, SMI#, STPCLK#
CMOS Input <sup>4</sup>	PWRGOOD
CMOS Output <sup>3</sup>	FERR#, IERR#, THERMTRIP#
System Bus Clock <sup>4</sup>	BCLK
APIC Clock <sup>4</sup>	PICCLK
APIC I/O <sup>3</sup>	PICD[1:0]
Power/Other <sup>5</sup>	BSEL[1:0], CLKREF, CPUPRES#, EDGCTRL, PLL[2:1], RESET2#, SLEWCTRL, THERMDN, THERMDP, RTTCTRL <sup>8</sup> , V <sub>COREDET</sub> , VID[3:0], V <sub>CC1.5</sub> , V <sub>CC2.5</sub> , V <sub>CCCMOS</sub> , V <sub>CCCORE</sub> , V <sub>REF</sub> , V <sub>SS</sub> , V <sub>TT</sub> , Reserved

**NOTES:**

- See Section 7.0 for information on these signals.
- The BR0# pin is the only BREQ# signal that is bidirectional. See Section 7.0 for more information. The internal BREQ# signals are mapped onto the BR[1:0]# pins after the agent ID is determined.
- These signals are specified for V<sub>CCCMOS</sub> (1.5 V for the Pentium III processor) operation.
- These signals are 2.5 V tolerant.
- V<sub>CCCORE</sub> is the power supply for the processor core and is described in Section 2.6. VID[3:0] is described in Section 2.6. V<sub>TT</sub> is used to terminate the system bus and generate V<sub>REF</sub> on the motherboard. V<sub>SS</sub> is system ground. V<sub>CC1.5</sub>, V<sub>CC2.5</sub>, V<sub>CCCMOS</sub> are described in Section 2.3. BSEL[1:0] is described in Section 2.8.2 and Section 7.0. All other signals are described in Section 7.0.
- RESET# must always be terminated to V<sub>TT</sub> on the motherboard, on-die termination is not provided for this signal.
- This signal is not supported by all processors. Refer to the Pentium® III Processor Specification Update for a complete listing of processors that support this pin.
- This signal is used to control the value of the processor on-die termination resistance. Refer to the platform design guide for the recommended pull-down resistor value.

**Table 4. System Bus Signal Groups (AGTL)<sup>1</sup> (Sheet 1 of 2)**

Group Name	Signals
AGTL Input <sup>9</sup>	BPRI#, BR1# <sup>7</sup> , DEFER#, RESET# <sup>6</sup> , RSP#, TRDY#, RS[2:0]#
AGTL Output <sup>9</sup>	PRDY#
AGTL I/O <sup>9</sup>	A[35:3]#, ADS#, AERR#, AP[1:0]#, BERR#, BINIT#, BNR#, BP[3:2]#, BPM[1:0]#, BR0# <sup>2</sup> , D[63:0]#, DBSY#, DEP[7:0]#, DRDY#, HIT#, HITM#, LOCK#, REQ[4:0]#, RP#,
CMOS Input <sup>3</sup>	A20M#, FLUSH#, IGNNE#, INIT#, LINT0/INTR, LINT1/NMI, PREQ#, SLP#, SMI#, STPCLK#
CMOS Input (1.8 V)	PWRGOOD
CMOS Output	FERR# <sup>3</sup> , IERR# <sup>3</sup> , THERMTRIP# <sup>3</sup> , VID[3:0] <sup>13</sup> , BSEL[1:0] <sup>13</sup>

Table 4. System Bus Signal Groups (AGTL)<sup>1</sup> (Sheet 2 of 2)

Group Name	Signals
System Bus Clock <sup>10, 12</sup> (1.25 V/2.5 V)	BCLK, BCLK0#
APIC Clock (2.0 V)	PICCLK <sup>11</sup>
APIC I/O <sup>3</sup>	PICD[1:0]
Power/Other <sup>5</sup>	BSEL[1:0], CLKREF <sup>10</sup> , CPUPRES#, EDGCTRL, PLL[2:1], RESET2#, SLEWCTRL, THERMDN, THERMDP, RTTCTRL <sup>8</sup> , V <sub>COREDET</sub> , VID[3:0], V <sub>CC1.5</sub> , V <sub>CC2.5</sub> , V <sub>CCCMOS</sub> , V <sub>CCCORE</sub> , V <sub>REF</sub> , V <sub>SS</sub> , V <sub>TT</sub> , Reserved

**NOTES:**

- See Section 7.0 for information on these signals.
- The BR0# pin is the only BREQ# signal that is bidirectional. See Section 7.0 for more information. The internal BREQ# signals are mapped onto the BR[1:0]# pins after the agent ID is determined.
- These signals are specified for V<sub>CCCMOS</sub> (1.5 V for the Pentium III processor) operation.
- These signals are 2.5 V tolerant.
- V<sub>CCCORE</sub> is the power supply for the processor core and is described in Section 2.6. VID[3:0] is described in Section 2.6. V<sub>TT</sub> is used to terminate the system bus and generate V<sub>REF</sub> on the motherboard. V<sub>SS</sub> is system ground. V<sub>CC1.5</sub>, V<sub>CC2.5</sub>, V<sub>CCCMOS</sub> are described in Section 2.3. BSEL[1:0] is described in Section 2.8.2 and Section 7.0. All other signals are described in Section 7.0.
- RESET# must always be terminated to V<sub>TT</sub> on the motherboard, on-die termination is not provided for this signal.
- This signal is not supported by all processors. Refer to the *Pentium® III Processor Specification Update* for a complete listing of processors that support this pin.
- This signal is used to control the value of the processor on-die termination resistance. Refer to the platform design guide for the recommended pull-down resistor value.
- These signals are also classified as AGTL. Refer to the *Pentium® III Processor Specification Update* for a complete listing of processors that support the AGTL and AGTL+ specifications.
- For differential clock systems, the CLKREF pin becomes BCLK#.
- For the Coppermine-T differential clock, this signal has been redefined to 2.0 V tolerant.
- 1.25 V signal for Differential clock application and 2.5 V for Single-ended clock application.
- This signal is 3.3 V.

## 2.8.1 Asynchronous vs. Synchronous for System Bus Signals

All AGTL+ signals are synchronous to BCLK. All of the CMOS, Clock, APIC, and TAP signals can be applied asynchronously to BCLK. All APIC signals are synchronous to PICCLK.



## 2.8.2 System Bus Frequency Select Signals (BSEL[1:0])

These signals are used to select the system bus frequency for the processor. The BSEL signals are also used by the chipset and system bus clock generator. Table 5 defines the possible combinations of the signals and the frequency associated with each combination. The frequency selection is determined by the processor(s) and driven out to the chipset and clock generator. All system bus agents must operate at the same frequency determined by the processor. **The Pentium III processor for the PGA370 socket operates at 100 MHz or 133 MHz system bus frequency; 66 MHz system bus operation is not supported.** Individual processors will only operate at their specified front side bus (FSB) frequency, either 100 MHz or 133 MHz, not both. Over or under-clocking the system bus frequency outside the specified rating marked on the package is not recommended.

On motherboards that support operation at either 100 MHz or 133 MHz, the BSEL1 signal must be pulled up to a logic high by a resistor located on the motherboard and provided as a frequency selection signal to the clock driver/synthesizer. This signal can also be incorporated into RESET# logic on the motherboard if only 133 MHz operation is supported (thus forcing the RESET# signal to remain active as long as the BSEL1 signal is low).

The BSEL0 signal will float from the processor and should be pulled up to a logic high by a resistor located on the motherboard. The BSEL0 signal can be incorporated into RESET# logic on the motherboard if 66 MHz operation is unsupported, as demonstrated in Figure 7. Refer to the appropriate clock synthesizer design guidelines and platform design guide for more details on the bus frequency select signals.

In a 2-way MP system design, these BSEL[1:0] signals must connect the pins of both processors.

**Figure 7. BSEL[1:0] Example for a 100/133 MHz or 100 MHz Only System Design**

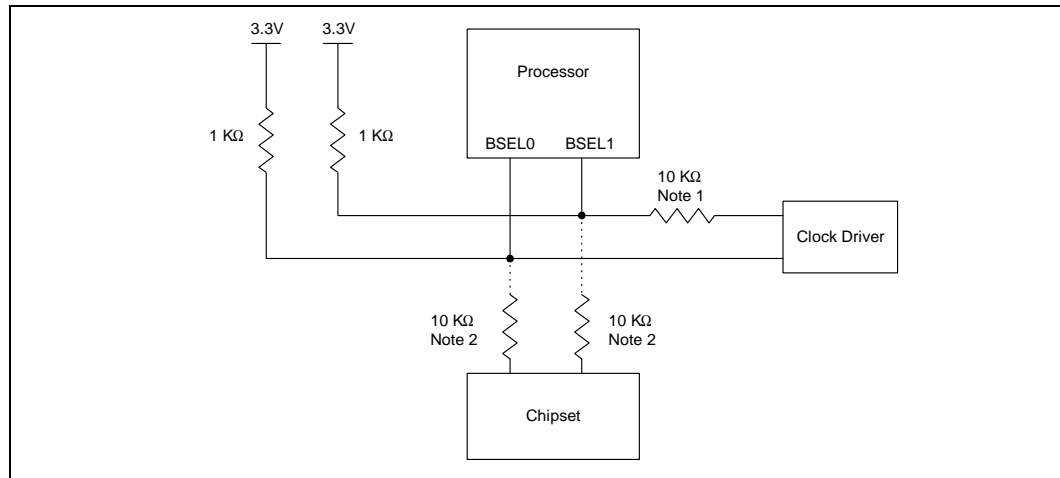

**NOTES:**

1. Some clock drivers may require a series resistor on their BSEL1 input.
2. Some chipsets may connect to the BSEL[1:0] signals and require a series resistor. See the appropriate platform design guide for implementation details.

Table 5. Frequency Select Truth Table for BSEL[1:0]

BSEL1	BSEL0	Frequency
0	0	66 MHz (unsupported)
0	1	100 MHz
1	0	Reserved
1	1	133 MHz

## 2.9 Maximum Ratings

Table 6 contains processor stress ratings only. Functional operation at the absolute maximum and minimum is not implied nor guaranteed. The processor should not receive a clock while subjected to these conditions. Functional operating conditions are given in the AC and DC tables in Section 2.10 through Section 2.12. Extended exposure to the maximum ratings may affect device reliability. Furthermore, although the processor contains protective circuitry to resist damage from static electric discharge, one should always take precautions to avoid high static voltages or electric fields.

Table 6. Absolute Maximum Ratings

Symbol	Parameter	Min	Max	Unit	Notes
T <sub>STORAGE</sub>	Processor storage temperature	-40	85	°C	
V <sub>CC</sub> CORE and V <sub>TT</sub>	Processor core voltage and termination supply voltage with respect to V <sub>SS</sub>	-0.5	2.1	V	
V <sub>in</sub> AGTL	AGTL+ buffer input voltage	V <sub>TT</sub> - 2.18	2.18	V	1, 2
V <sub>in</sub> CMOS <sup>1,5</sup>	CMOS buffer DC input voltage with respect to V <sub>SS</sub>	V <sub>TT</sub> - 2.18	2.18	V	1, 2, 3
V <sub>in</sub> CMOS <sup>2,5</sup>	CMOS buffer DC input voltage with respect to V <sub>SS</sub>	-0.58	3.18	V	4
I <sub>VID</sub>	Max VID pin current	-0.3	5	mA	
I <sub>CPUPRES#</sub>	Max CPUPRES# pin current		5	mA	

### NOTES:

1. Input voltage can never exceed V<sub>SS</sub> + 2.18 V.
2. Input voltage can never go below V<sub>TT</sub> - 2.18 V.
3. Parameter applies to CMOS (except BCLK, PICCLK, and PWRGOOD) and APIC bus signal groups only.
4. Parameter applies to CMOS signals BCLK, PICCLK, and PWRGOOD only.

## 2.10 Processor DC Specifications

The processor DC specifications in this section are defined at the PGA370 socket pins (bottom side of the motherboard). See [Section 7.0](#) for the processor signal descriptions and [Section 5.4](#) for the signal listings.

Most of the signals on the processor system bus are in the AGTL+ (AGTL) signal group. These signals are specified to be terminated to 1.5 V for AGTL+ or 1.25 V for AGTL. The DC specifications for these signals are listed in [Table 9 on page 34](#).

To allow connection with other devices, the clock, CMOS, and APIC signals are designed to interface at non-AGTL+ levels. The DC specifications for these pins are listed in [Table 11 on page 35](#).

[Table 7](#) through [Table 12](#) list the DC specifications for the Pentium III processor for the PGA370 socket. Specifications are valid only while meeting specifications for junction temperature, clock frequency, and input voltages. Care should be taken to read all notes associated with each parameter.



Table 7. Voltage and Current Specifications <sup>1,2</sup> (Sheet 1 of 5)

Symbol	Parameter	Processor		Min	Typ	Max	Unit	Notes
		Core Freq	CPUID					
VCCCORE	Vcc for Processor Core	500E MHz	0x681		1.60		V	3,4
			0x683		1.60			3,4
			0x686		n/a			3,4
		533EB MHz	0x681		1.65			3,4
			0x683		1.65			3,4
			0x686		n/a			3,4
		550E MHz	0x681		1.60			3,4
			0x683		1.65			3,4
			0x686		1.70			3,4
		600E MHz	0x681		1.65			3,4
			0x683		1.65			3,4
			0x686		1.70			3,4
			0x68A		1.75			3,4
		600EB MHz	0x681		1.65			3,4
			0x683		1.65			3,4
			0x686		1.70			3,4
		650 MHz	0x681		1.65			3,4
			0x683		1.65			3,4
			0x686		1.70			3,4
		667 MHz	0x681		1.65			3,4
			0x683		1.65			3,4
			0x686		1.70			3,4
		700 MHz	0x681		1.65			3,4
			0x683		1.65			3,4
			0x686		1.70			3,4
			0x68A		1.75			3,4
		733 MHz	0x681		1.65			3,4
			0x683		1.65			3,4
			0x686		1.70			3,4
			0x68A		1.75			3,4
		750 MHz	0x681		1.65			3,4
			0x683		1.65			3,4
			0x686		1.70			3,4
			0x68A		1.75			3,4



Table 7. Voltage and Current Specifications <sup>1, 2</sup> (Sheet 2 of 5)

Symbol	Parameter	Processor		Min	Typ	Max	Unit	Notes
		Core Freq	CPUID					
V <sub>CC</sub> CORE	Vcc for Processor Core	800 MHz	0x681		1.65		V	3,4
			0x683		1.65			3,4
			0x686		1.70			3,4
		800EB MHz	0x681		1.65			3,4
			0x683		1.65			3,4
			0x686		1.70			3,4
			0x68A		1.75			3,4
		850 MHz	0x681		1.65			3,4
			0x683		1.65			3,4
			0x686		1.70			3,4
			0x68A		1.75			3,4
		866 MHz	0x681		1.65			3,4
			0x683		1.65			3,4
			0x686		1.70			3,4
			0x68A		1.75			3,4
		900 MHz	0x686		1.70			3,4
			0x68A		1.75			3,4
		933 MHz	0x683		1.65			3,4
			0x686		1.70			3,4
			0x68A		1.75			3,4,20
		1 GHz	0x68A		1.75			3,4
		1B GHz	0x686		1.70			3,4
			0x686		1.76			3,4,18,19
			0x68A		1.75			3,4,20
1.10 GHz	0x68A		1.75		3,4			
1.13 GHz	0x68A		1.75		3,4			



Table 7. Voltage and Current Specifications <sup>1,2</sup> (Sheet 3 of 5)

Symbol	Parameter	Processor		Min	Typ	Max	Unit	Notes
		Core Freq	CPUID					
V <sub>TT</sub>	Static AGTL+ bus termination voltage			1.455	1.50	1.545	V	1.5 ±3% <sup>5,16</sup>
	Static AGTL bus termination voltage			1.213	1.25	1.288	V	1.25 ±3% <sup>5,16,17</sup>
V <sub>TT</sub>	Transient AGTL+ bus termination voltage			1.365	1.50	1.635	V	1.5 ±9% <sup>5</sup>
	Transient AGTL bus termination voltage			1.138	1.25	1.363	V	1.25 ±9% <sup>5,17</sup>
V <sub>CC1.5</sub>	Static AGTL+ bus termination voltage			1.455	1.50	1.545	V	1.5 ±3%
V <sub>REF</sub>	AGTL+ input reference voltage			-2%	2/3 V <sub>TT</sub>	+2%	V	±2%, 7
V <sub>CLKREF</sub>	CLKREF input reference voltage			1.169	1.25	1.331	V	±6.5%, 15
Baseboard V <sub>CC</sub> CORE Tolerance, Static	Processor core voltage static tolerance level at the PGA370 socket pins			-0.080 0.001		0.040 0.100	V	6 18, 19
Baseboard V <sub>CC</sub> CORE Tolerance, Transient	Processor core voltage transient tolerance level at the PGA370 socket pins			-0.130 -0.110 -0.025		0.080 0.080 0.130	V	6 17 18, 19



Table 7. Voltage and Current Specifications <sup>1, 2</sup> (Sheet 4 of 5)

Symbol	Parameter	Processor		Min	Typ	Max	Unit	Notes
		Core Freq	CPUID					
Icc <sub>CORE</sub>	Icc for processor core	500E MHz	0x683			10.0	A	3, 8, 9
		600E MHz	0x686			12.0		3, 8, 9
			0x68A			12.6		3, 8, 9
		600EB MHz	0x686			12.0		3, 8, 9
		650 MHz	0x686			13.0		3, 8, 9
		667B MHz	0x686			13.3		3, 8, 9
		700 MHz	0x686			14.0		3, 8, 9
			0x68A			14.8		3, 8, 9
		733B MHz	0x686			14.6		3, 8, 9
			0x68A			15.4		3, 8, 9
		750 MHz	0x686			15.0		3, 8, 9
			0x68A			15.7		3, 8, 9
		800 MHz	0x686			16.0		3, 8, 9
		800EB MHz	0x686			16.0		3, 8, 9
			0x68A			16.6		3, 8, 9
		850 MHz	0x686			16.2		3, 8, 9
			0x68A			17.3		3, 8, 9
		866 MHz	0x686			16.3		3, 8, 9
			0x68A			17.6		3, 8, 9
		900 MHz	0x686			17.0		3, 8, 9
0x68A				18.4	3, 8, 9			
933 MHz	0x686			17.7	3, 8, 9			
	0x68A			18.8	3, 8, 9, 20			
1 B GHz	0x686			19.4	3, 8, 9			
	0x68A			20.2	3, 8, 9, 20			
1 GHz	0x68A			20.2	3, 8, 9			
1.10 GHz	0x68A			22.6	3, 8, 9			
1.13 GHz	0x68A			22.6	3, 8, 9, 20			

Table 7. Voltage and Current Specifications <sup>1, 2</sup> (Sheet 5 of 5)

Symbol	Parameter	Processor		Min	Typ	Max	Unit	Notes
		Core Freq	CPUID					
ICC <sub>CMOS</sub>	ICC for V <sub>CC</sub> <sub>CMOS</sub>					250	mA	
ICLKREF	CLKREF voltage supply current					60	μA	
IVTT	Termination voltage supply current					2.7	A	10
ISGnt	ICC Stop-Grant for processor core					6.9	A	8, 11
ISLP	ICC Sleep for processor core					6.9	A	8
IDSLP	ICC Deep Sleep for processor core					6.6	A	8
dICC <sub>CORE</sub> /dt	Power supply current slew rate					240	A/μs	12, 13, 14
dI <sub>VTT</sub> /dt	Termination current slew rate					8	A/μs	12, 13, See Table 12

**NOTES:**

1. Unless otherwise noted, all specifications in this table apply to all processor frequencies.
2. All specifications in this table apply only to the Pentium III processor. For motherboard compatibility with the Celeron processor, see the *Intel® Celeron™ Processor Datasheet*.
3. V<sub>CC</sub><sub>CORE</sub> and I<sub>CC</sub><sub>CORE</sub> supply the processor core and the on-die L2 cache.
4. Use the "typical voltage" specification with the "tolerance specifications" to provide correct voltage regulation to the processor.
5. V<sub>TT</sub> and V<sub>CC1.5</sub> must be held to 1.5 V ±9% while the AGTL+ bus is active. It is required that V<sub>TT</sub> and V<sub>CC1.5</sub> be held to 1.5 V ±3% while the processor system bus is static (idle condition). The ±3% range is the required design target; ±9% will come from the transient noise added. This is measured at the PGA370 socket pins on the bottom side of the baseboard.
6. **These are the tolerance requirements, across a 20 MHz frequency bandwidth, measured at the processor socket pin on the soldered-side of the motherboard.** V<sub>CC</sub><sub>CORE</sub> must return to within the static voltage specification within 100 μs after a transient event; see the *VRM 8.4 DC-DC Converter Design Guidelines* for further details.
7. V<sub>REF</sub> should be generated from V<sub>TT</sub> by a voltage divider of 1% resistors or 1% matched resistors. Refer to the *Intel® Pentium® II Processor Developer's Manual* for more details on V<sub>REF</sub>.
8. Maximum ICC is measured at V<sub>CC</sub> typical voltage and under a maximum signal loading conditions.
9. Voltage regulators may be designed with a minimum equivalent internal resistance to ensure that the output voltage, at maximum current output, is no greater than the nominal (i.e., typical) voltage level of V<sub>CC</sub><sub>CORE</sub> (V<sub>CC</sub><sub>CORE\_TYP</sub>). In this case, the maximum current level for the regulator, I<sub>CC</sub><sub>CORE\_REG</sub>, can be reduced from the specified maximum current I<sub>CC</sub><sub>CORE\_MAX</sub> and is calculated by the equation:

$$I_{CC_{CORE\_REG}} = I_{CC_{CORE\_MAX}} \times (V_{CC_{CORE\_TYP}} - V_{CC_{CORE\_STATIC\_TOLERANCE}}) / V_{CC_{CORE\_TYP}}$$

10. The current specified is the current required for a single processor. A similar amount of current is drawn through the termination resistors on the opposite end of the AGTL+ bus, unless single-ended termination is used (see [Section 2.1](#)).
11. The current specified is also for AutoHALT state.
12. Maximum values are specified by design/characterization at nominal V<sub>CC</sub><sub>CORE</sub>.
13. Based on simulation and averaged over the duration of any change in current. Use to compute the maximum inductance tolerable and reaction time of the voltage regulator. This parameter is not tested.
14. dlcc/dt specifications are measured and specified at the PGA370 socket pins.
15. CLKREF must be held to 1.25 V ±6.5%. This tolerance accounts for a ±5% power supply and ±1% resistor divider tolerance. It is recommended that the motherboard generate the CLKREF reference from either the 2.5 V or 3.3 V supply. V<sub>TT</sub> should not be used due to risk of AGTL+ switching noise coupling to this analog reference.
16. Static voltage regulation includes: DC output initial voltage set point adjust, Output ripple and noise, Output load ranges specified in the tables above.
17. This specification applies to PGA370 processors operating at frequencies of 933 MHz or higher.



- 18. This specification only applies to 1B GHz S-spec #: SL4WM. This part has a VID request of 1.70 V, however the processor should be supplied 1.76 V at the PGA Vcc pin by the Voltage Regulator Circuit or VRM.
- 19. This specification applies only to 1B GHz S-spec #: SL4WM. This value is 60 mV offset from the standard specification and more at the Minimum specification. These tolerances are measured from a 1.70 V base, while Vcc supplied is 1.76 V.
- 20. This processor exists in both FC-PGA and FC-PGA2.

### 2.10.1 Icc Slew Rate Specifications

This section contains typical current slew rate data for processors covered by this design guideline. Actual slew rate values and wave-shapes may vary slightly depending on the type and size of decoupling capacitors used in a particular implementation.

Figure 8. Slew Rate (23A Load Step)

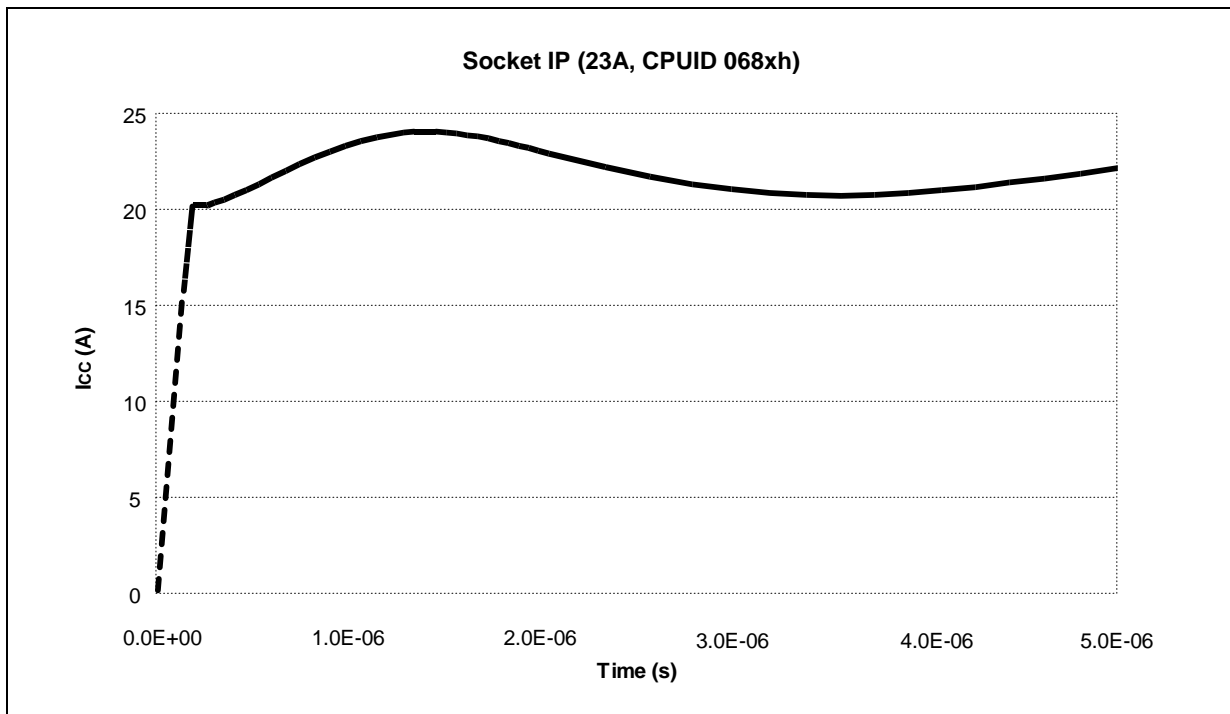

Table 8. PL Slew Rate Data (23A) (Sheet 1 of 2)

Time (μs)	Icc (A)
0.1	9.55
0.15	14.4
0.5	20.85
1	23.04
1.5	23.44
2	23.28
2.5	22.32
3	21.63
3.5	21.45
4	21.63

Table 8. PL Slew Rate Data (23A) (Sheet 2 of 2)

Time ( $\mu$ s)	I <sub>cc</sub> (A)
4.5	21.88
5	22.01

Table 9. AGTL / AGTL+ Signal Groups DC Specifications <sup>1</sup>

Symbol	Parameter	Min	Max	Unit	Notes
V <sub>IL</sub>	Input Low Voltage	-0.150	V <sub>REF</sub> - 0.200	V	6
V <sub>IH</sub>	Input High Voltage	V <sub>REF</sub> + 0.200	V <sub>TT</sub>	V	2, 3, 6
R <sub>on</sub>	Buffer On Resistance		16.67	$\Omega$	5
I <sub>L</sub>	Leakage Current for inputs, outputs, and I/O		$\pm$ 100	$\mu$ A	4

**NOTES:**

1. Unless otherwise noted, all specifications in this table apply to Pentium III processors at all frequencies.
2. All inputs, outputs, and I/O pins must comply with the signal quality specifications in Section 3.0.
3. Minimum and maximum V<sub>TT</sub> are given in Table 12 on page 36.
4. ( $0 \leq V_{IN} \leq 1.5$  V +3%) and ( $0 \leq V_{OUT} \leq 1.5$  V +3%).
5. Refer to the processor I/O Buffer Models for I/V characteristics.
6. Steady state input voltage must not be above V<sub>SS</sub> + 1.65 V or below V<sub>TT</sub> - 1.65 V.

Table 10. Non-AGTL+ Signal Group DC Specifications <sup>1</sup>

Symbol	Parameter	Min	Max	Unit	Notes
V <sub>IL1.5</sub>	Input Low Voltage	-0.150	V <sub>CMOS_REF</sub> - 0.200	V	9
V <sub>IL2.5</sub>	Input Low Voltage	-0.58	0.700	V	5, 8
V <sub>IH1.5</sub>	Input High Voltage	V <sub>CMOS_REF</sub> + 0.200	1.5	V	6, 9
V <sub>IH2.5</sub>	Input High Voltage	2.000	3.18	V	5, 8
V <sub>OL</sub>	Output Low Voltage		0.400	V	2
R <sub>on</sub>			35		2
V <sub>OH</sub>	Output High Voltage		1.5	V	7, 9, All outputs are open-drain
I <sub>OL</sub>	Output Low Current	9		mA	
I <sub>LI</sub>	Input Leakage Current		$\pm$ 100	$\mu$ A	3, 6
I <sub>LO</sub>	Output Leakage Current		$\pm$ 100	$\mu$ A	4, 7

**NOTES:**

1. Unless otherwise noted, all specifications in this table apply to Pentium III processors at all frequencies.
2. Parameter measured at 9 mA (for use with TTL inputs).
3. ( $0 \leq V_{IN} \leq 2.5$  V +5%).
4. ( $0 \leq V_{OUT} \leq 2.5$  V +5%).
5. For BCLK specifications, refer to Table 24 on page 51.
6. ( $0 \leq V_{IN} \leq 1.5$  V +3%).
7. ( $0 \leq V_{OUT} \leq 1.5$  V +3%).
8. Applies to non-AGTL signals except BCLK, PICCLK, and PWRGOOD.
9. Applies to non-AGTL signals **except** BCLK, PICCLK, and PWRGOOD.

Table 11. Non-AGTL Signal Group DC Specifications <sup>1</sup>

Symbol	Parameter	Min	Max	Unit	Notes
V <sub>IL1.5</sub>	Input Low Voltage	-0.150	V <sub>CMOS_REF</sub> - 0.300	V	7, 8
V <sub>IL2.5</sub>	Input Low Voltage	-0.58	0.700	V	4, 6
V <sub>IH1.5</sub>	Input High Voltage	V <sub>CMOS_REF</sub> + 0.200	1.5	V	5, 7
V <sub>IH2.5</sub>	Input High Voltage	2.000	3.18	V	4, 6
V <sub>OL</sub>	Output Low Voltage		0.300	V	2
R <sub>on</sub>			35		2
V <sub>OH</sub>	Output High Voltage		1.5	V	5, 7, All outputs are open-drain
I <sub>OL</sub>	Output Low Current	9		mA	
I <sub>LI</sub>	Input Leakage Current		±100	µA	3, 5
I <sub>LO</sub>	Output Leakage Current		±100	µA	3, 5

**NOTES:**

1. Unless otherwise noted, all specifications in this table apply to Pentium III processors at all frequencies.
2. Parameter measured at 9 mA (for use with TTL inputs).
3. (0 ≤ V<sub>IN</sub> ≤ 2.5 V +5%); (0 ≤ V<sub>OUT</sub> ≤ 2.5 V +5%).
4. For BCLK specifications, refer to [Table 24 on page 51](#).
5. (0 ≤ V<sub>IN</sub> ≤ 1.5 V +3%); (0 ≤ V<sub>OUT</sub> ≤ 1.5 V +3%).
6. Applies to non-AGTL+ signals **except** BCLK, PICCLK, and PWRGOOD.
7. Applies to non-AGTL+ signals **except** BCLK, PICCLK, and PWRGOOD.
8. For Coppermine-T differential clocking, the input low voltage is (V<sub>CMOS\_REF</sub> - 0.300)V.

## 2.11 AGTL / AGTL+ System Bus Specifications

It is recommended that the AGTL+ bus be routed in a daisy-chain fashion with termination resistors to VTT. These termination resistors are placed electrically between the ends of the signal traces and the VTT voltage supply and generally are chosen to approximate the system platform impedance. The valid high and low levels are determined by the input buffers using a reference voltage called V<sub>REF</sub>. Refer to the appropriate platform design guide for more information

Table 12 below lists the nominal specification for the AGTL+ termination voltage (VTT). The AGTL+ reference voltage (V<sub>REF</sub>) is generated on the system motherboard and should be set to 2/3 VTT for the processor and other AGTL+ logic. It is important that the baseboard impedance be specified and held to a ±15% tolerance, and that the intrinsic trace capacitance for the AGTL+ signal group traces is known and well-controlled. For more details on the AGTL+ buffer specification, see the *Intel® Pentium® II Processor Developer's Manual* and AP-585, *Intel® Pentium® II Processor AGTL+ Guidelines*.

**Table 12. Processor AGTL+ Bus Specifications** <sup>1, 2</sup>

Symbol	Parameter	Min	Typ	Max	Units	Notes
VTT	Bus Termination Voltage		1.50		V	3
On-die R <sub>TT</sub>	Termination Resistor	40		130	Ω	4
V <sub>REF</sub>	Bus Reference Voltage	0.950	2/3 VTT	1.05	V	5

**NOTES:**

- Unless otherwise noted, all specifications in this table apply to Pentium III processors at all frequencies.
- Pentium III processors for the PGA370 socket contain AGTL+ termination resistors on the processor die, except for the RESET# input.
- VTT and V<sub>CC1.5</sub> must be held to 1.5 V ±9%. It is required that VTT and V<sub>CC1.5</sub> be held to 1.5 V ±3% while the processor system bus is idle (static condition). This is measured at the PGA370 socket pins on the bottom side of the baseboard.
- The value of the on-die R<sub>TT</sub> is determined by the resistor value measured by the RTTCTRL signal pin. See [Section 7.0](#) for more details on the RTTCTRL signal. Refer to the recommendation guidelines for the specific chipset/processor combination.
- V<sub>REF</sub> is generated on the motherboard and should be 2/3 VTT ±2% nominally. Insure that there is adequate V<sub>REF</sub> decoupling on the motherboard.

**Table 13. Processor AGTL Bus Specifications** <sup>1, 2</sup>

Symbol	Parameter	Min	Typ	Max	Units	Notes
VTT	Bus Termination Voltage	1.14	1.25	1.308	V	3
On-die R <sub>TT</sub>	Termination Resistor	50 <sup>6</sup>	56, 68	115	Ω	4, 7
V <sub>REF</sub>	Bus Reference Voltage	2/3 VTT - 2%	2/3 VTT	2/3 VTT + 2%	V	5

**NOTES:**

- Specifications in this table do not apply to Pentium III processors at all frequencies. Please refer to the *Intel® Pentium® III Processor Specification Update* for a complete listing on the processors that support the AGTL specification.
- Pentium III processors for the PGA370 socket contain AGTL termination resistors on the processor die, except for the RESET# input.
- VTT must be held to 1.25 V ±9%. It is required that VTT be held to 1.25 V ±3% while the processor system bus is idle (static condition). This is measured at the PGA370 socket pins on the bottom side of the baseboard.
- The value of the on-die R<sub>TT</sub> is determined by the resistor value measured by the RTTCTRL signal pin. The on-die R<sub>TT</sub> has a resistance tolerance of ±15%. See [Section 7.0](#) for more details on the RTTCTRL signal. Refer to the recommendation guidelines for the specific chipset/processor combination.
- V<sub>REF</sub> is generated on the motherboard and should be 2/3 VTT ±2% nominally. Insure that there is adequate V<sub>REF</sub> decoupling on the motherboard.
- For the Coppermine-T differential clock platform, the on-die R<sub>TT</sub> min should be 50 Ω.
- Coppermine-T UP platforms require a 56Ω resistor and Coppermine-T DP platforms require a 68Ω resistor. Tolerance for the on-die R<sub>TT</sub> is ±10% for 56Ω and 68Ω resistors and ±15% for 100 Ω resistors

## 2.12 System Bus AC Specifications

The processor system bus timings specified in this section are defined at the socket pins on the bottom of the motherboard. Unless otherwise specified, timings are tested at the processor pins during manufacturing. Timings at the processor pins are specified by design characterization. See Section 7.0 for the processor signal definitions.

Table 14 through Table 20 list the AC specifications associated with the processor system bus. These specifications are placed into the following categories: Table 14 and Table 15 contain the system bus clock specifications, Table 16 contains the AGTL+/AGTL specifications, Table 17 contains the CMOS signal group specifications, Table 18 contains timings for the reset conditions, Table 19 and covers APIC bus timing, and Table 20 covers power on timing.

All processor system bus AC specifications for the AGTL+/AGTL signal group are relative to the rising edge of the BCLK input. All AGTL+/AGTL timings are referenced to  $V_{REF}$  for both '0' and '1' logic levels unless otherwise specified.

The timings specified in this section should be used in conjunction with the I/O buffer models provided by Intel. These I/O buffer models, which include package information, are available for the Pentium III processor in the FC-PGA package in Viewlogic\* XTK/XNS\* model format (formerly known as QUAD format) and IBIS \* 3.1 format as the *Pentium III Processor for the PGA370 Socket I/O Buffer Models* (Electronic Format).

AGTL and AGTL+ layout guidelines are also available in the appropriate platform design guide.

Care should be taken to read all notes associated with a particular timing parameter.

### 2.12.1 I/O Buffer Model

An electronic copy of the I/O Buffer Model for the AGTL+ and CMOS signals is available at Intel's Developer's Website (<http://developer.intel.com>). The model is for use in single processor designs and assumes the presence of motherboard  $R_{TT}$  values as described in Table 12 on page 36.

**Table 14. System Bus AC Specifications (SET Clock)<sup>1, 2</sup>**

T# Parameter	Min	Nom	Max	Unit	Figure	Notes
System Bus Frequency		100.00 133.33		MHz		4
T1: BCLK Period	10.0 7.5			ns	9	4, 5, 10 4, 5, 11
T2: BCLK Period Stability			±250 ±250	ps		6, 7, 10 6, 7, 11
T3: BCLK High Time	2.5 1.4			ns	9	9, 10 9, 11
T4: BCLK Low Time	2.4 1.4			ns	9	9, 10 9, 11
T5: BCLK Rise Time	0.4		1.6	ns	9	3, 8
T6: BCLK Fall Time	0.4		1.6	ns	9	3, 8

**NOTES:**

1. Unless otherwise noted, all specifications in this table apply to Pentium III processors at all frequencies.
2. All AC timings for the AGTL+ signals are referenced to the BCLK rising edge at 1.25 V at the processor pin. All AGTL+ signal timings (address bus, data bus, etc.) are referenced at 1.00 V at the processor pins.

3. Not 100% tested. Specified by design characterization as a clock driver requirement.
4. The internal core clock frequency is derived from the processor system bus clock. The system bus clock to core clock ratio is determined during initialization. Individual processors will only operate at their specified system bus frequency, either 100 MHz or 133 MHz, not both.
5. The BCLK period allows a +0.5 ns tolerance for clock driver variation. See the appropriate clock synthesizer/driver specification for details.
6. Due to the difficulty of accurately measuring clock jitter in a system, it is recommended that a clock driver be used that is designed to meet the period stability specification into a test load of 10 to 20 pF. This should be measured on the **rising edges of adjacent BCLKs crossing 1.25 V at the processor pin**. The jitter present must be accounted for as a component of BCLK timing skew between devices.
7. The clock driver's closed loop jitter bandwidth must be set low to allow any PLL-based device to track the jitter created by the clock driver. The -20 dB attenuation point, as measured into a 10 to 20 pF load, should be less than 500 kHz. This specification may be ensured by design characterization and/or measured with a spectrum analyzer. See the appropriate clock synthesizer/driver specification for details.
8. BCLK Rise time is measure between 0.5 V–2.0 V. BCLK fall time is measured between 2.0 V–0.5 V.
9. BCLK high time is measured as the period of time above 2.0 V. BCLK low time is measured as the period of time below 0.5 V.
10. This specification applies to Pentium III processors operating at a system bus frequency of 100 MHz.
11. This specification applies to Pentium III processors operating at a system bus frequency of 133 MHz.

**Table 15. System Bus Timing Specifications (Differential Clock)<sup>1, 11, 12</sup>**

Parameter	133 MHz		100 MHz		Units	Notes
	Min	Max	Min	Max		
Clock Period—Average	7.5	7.7	10.0	10.2	ns	2, 9, 10
Instantaneous Minimum Clock Period	7.30		9.8		ns	2, 9, 10
CLK Differential Rise Time	175	550	175	467	ps	1, 3
CLK Differential Fall Time	175	550	175	467	ps	1, 3
Waveform Symmetry		325		325	ps	4
Differential Cycle to Cycle Jitter		200		200	ps	1, 5
Differential Duty Cycle	45%	55%	45%	55%		1
Rising Edge Ring Back	0.35		0.35		V	1, 6
Falling Edge Ring Back		-0.35		-0.35	V	1, 6
Cross Point at 1V	0.51	0.76	0.51	0.76	V	7
Input High Voltage	0.92	1.45	0.92	1.45	V	8
Input Low Voltage	-0.2	0.35	-0.2	0.35	V	8

**NOTES:**

1. Measurement taken from differential waveform, defined as BCLK - BCLK#.
2. Period is defined from one rising 0 V-crossing to the next.
3. Measurement taken from differential waveform, voltage range from -0.35 V to +0.35 V.
4. Measurement taken from common mode waveform, measure rise/fall time from 0.41 V to 0.86 V. Rise/fall time matching is defined as "the instantaneous difference between maximum BCLK rise (fall) and minimum BCLK# fall (rise) time, or minimum BCLK rise (fall) and maximum BCLK# fall (rise) time." This parameter is designed to guard waveform symmetry.
5. Period difference measured around 0 V-crossings; measurement taken from differential waveform.
6. The rising and falling edge ringback voltage specified is the minimum (rising) or them maximum (falling) voltage, the differential waveform can go after passing Vih\_diff (rising) or Vil\_diff (falling)
7. Measured in absolute voltage, i.e. single-ended measurement. Includes every cross point for both rise and fall of BCLK.
8. Input high or input low voltage range measured in absolute voltage, i.e. single-ended measurement.
9. The internal Core clock frequency is derived from the processor system bus clock. The system bus clock to core clock ratio is determined during initialization. Individual processors will only operate at their specified system bus frequency 133 MHz. Table 16 shows supported ratios for each processor
10. Due to the difficulty of accurately measuring clock jitter in a system, it is recommended that a clock driver be used that is designed to meet the period stability specification into a test load of 10 pF to 20 pF. The jitter must be accounted for as a component of BCLK timing skew between devices.
11. AC parameters are measured at the processor pins.
12. BCLK/BCLK# must rise/fall monotonically between Vil and Vih.

**Table 16. System Bus AC Specifications (AGTL+ or AGTL Signal Group)<sup>1, 2, 3, 13</sup>**

T# Parameter	Min	Max	Unit	Figure	Notes
T7: AGTL+ Output Valid Delay	0.40	3.25	ns	11	4, 10, 11
T8: AGTL+ Input Setup Time	1.20		ns	12	5, 6, 7, 10
	0.95		ns	12	5, 6, 7, 11, 12
T9: AGTL+ Input Hold Time	1.00		ns	12	8, 10
T10: RESET# Pulse Width	1.00		ms	13	6, 9, 10

**NOTES:**

1. Unless otherwise noted, all specifications in this table apply to Pentium III processors at all frequencies.
2. These specifications are tested during manufacturing.
3. All timings for the AGTL+ signals are referenced to the BCLK rising edge at 1.25 V at the processor pins (for AGTL, the timings are referenced to the rising edge of BCLK and the falling edge of BCLK# at the processor pins). All AGTL+ signal timings (compatibility signals, etc.) are referenced at 1.00 V (2/3 V<sub>TT</sub> for AGTL) at the processor pins.
4. Valid delay timings for these signals are specified into 50 Ω to 1.5 V, V<sub>REF</sub> at 1.0 V ±2% and with 56 Ω on-die R<sub>TT</sub>. For AGTL platforms, the valid delay timings are specified into 50 Ω to 1.25 V, V<sub>REF</sub> at 2/3 V<sub>TT</sub> ±2% and with 56 Ω on-die R<sub>TT</sub>.
5. A minimum of 3 clocks must be guaranteed between two active-to-inactive transitions of TRDY#.
6. RESET# can be asserted (active) asynchronously, but must be deasserted synchronously. For 2-way MP systems, RESET# should be synchronous.
7. Specification is for a minimum 0.40 V swing from V<sub>REF</sub> - 200 mV to V<sub>REF</sub> + 200 mV. This assumes an edge rate of 0.3V/ns.
8. Specification is for a maximum 1.0 V (2/3 V<sub>TT</sub> for AGTL) swing from V<sub>TT</sub> - 1V to V<sub>TT</sub>. This assumes an edge rate of 3V/ns.
9. This should be measured after V<sub>CC</sub>CORE, V<sub>TT</sub>, V<sub>CC</sub>CMOS, and BCLK become stable.
10. This specification applies to the Pentium III processor running at 100 MHz system bus frequency.
11. This specification applies to the Pentium III processor running at 133 MHz system bus frequency.
12. BREQ signals at 133 MHz system bus observe a 1.2 ns minimum setup time.
13. For AGTL, V<sub>REF</sub> is 2/3 V<sub>TT</sub> ±3%.

**Table 17. System Bus AC Specifications (CMOS Signal Group) <sup>1, 2, 3, 4</sup>**

T# Parameter	Min	Max	Unit	Figure	Notes
T14: CMOS Input Pulse Width, except PWRGOOD	2		BCLKs	11	Active and Inactive states
T15: PWRGOOD Inactive Pulse Width	10		BCLKs	11, 14	5

**NOTES:**

1. Unless otherwise noted, all specifications in this table apply to Pentium III processors at all frequencies
2. These specifications are tested during manufacturing.
3. These signals may be driven asynchronously.
4. All CMOS outputs shall be asserted for at least 2 BCLKs.
5. When driven inactive or after  $V_{CC_{CORE}}$ ,  $V_{TT}$ ,  $V_{CC_{CMOS}}$ , and BCLK become stable.

**Table 18. System Bus AC Specifications (Reset Conditions) <sup>1</sup>**

T# Parameter	Min	Max	Unit	Figure	Notes
T16: Reset Configuration Signals (A[14:5]#, BR0#, INIT#) Setup Time	4		BCLKs	13	Before deassertion of RESET#
T17: Reset Configuration Signals (A[14:5]#, BR0#, INIT#) Hold Time	2	20	BCLKs	13	After clock that deasserts RESET#

**NOTE:** 1. Unless otherwise noted, all specifications in this table apply to all Pentium III processor frequencies.

**Table 19. System Bus AC Specifications (APIC Clock and APIC I/O) <sup>1, 2, 3</sup>**

T# Parameter	Min	Max	Unit	Figure	Notes
T21: PICCLK Frequency	2.0	33.3	MHz		
T22: PICCLK Period	30.0	500.0	ns	9	
T23: PICCLK High Time	10.5		ns	9	@ > 1.7V
T24: PICCLK Low Time	10.5		ns	9	@ < 0.7V
T25: PICCLK Rise Time	0.25	3.0	ns	9	(0.7V - 1.7V)
T26: PICCLK Fall Time	0.25	3.0	ns	9	(1.7V - 0.7V)
T27: PICD[1:0] Setup Time	5.0		ns	12	4
T28: PICD[1:0] Hold Time	2.5		ns	12	4
T29a: PICD[1:0] Valid Delay (Rising Edge)	1.5	8.7	ns	10, 11	4, 5, 6
T29b: PICD[1:0] Valid Delay (Falling Edge)	1.5	12.0	ns	10, 11	4, 5, 6

**NOTES:**

1. Unless otherwise noted, all specifications in this table apply to Pentium III processors at all frequencies.
2. These specifications are tested during manufacturing.
3. All AC timings for the APIC I/O signals are referenced to the PICCLK rising edge at 1.25 V at the processor pins. All APIC I/O signal timings are referenced at 0.75 V at the processor pins.
4. Referenced to PICCLK rising edge.
5. For open drain signals, valid delay is synonymous with float delay.
6. Valid delay timings for these signals are specified into 150  $\Omega$  load pulled up to 1.5 V.

**Table 20. Platform Power-On Timings<sup>2</sup>**

T# Parameter	Min	Max	Unit	Figure	Notes
T45: Valid Time Before $V_{TT\_PWRGD}$	1.0		mS	14	1
T46: Valid Time Before PWRGOOD	2.0		mS	14	1
T47: RESET# Inactive to Valid Outputs	1		BCLK	14	1
T48: RESET# Inactive to Drive Signals	4		BCLK	14	1

**NOTES:**



1. All signals, during their invalid states, must be guarded against spurious levels from effecting the platform during processor power-up sequence.
2. Configuration Input signals include: A[14:5], BR0#, BR1#, INIT#. For timing of these signals, please refer to Table 17 and Figure 13.

**Note:** For Figure 9 through Figure 15, the following apply:

1. Figure 9 through Figure 15 are to be used in conjunction with Table 14 through Table 20.
2. All AC timings for the AGTL+ signals at the processor pins are referenced to the BCLK rising edge at 1.25 V. All AGTL+ signal timings (address bus, data bus, etc.) are referenced at 1.00 V at the processor pins.
3. All AC timings for the APIC I/O signals at the processor pins are referenced to the PICCLK rising edge at 1.25 V. All APIC I/O signal timings are referenced at 0.75 V at the processor pins.
4. All AC timings for the TAP signals at the processor pins are referenced to the TCK rising edge at 0.75 V. All TAP signal timings (TMS, TDI, etc.) are referenced at 0.75 V at the processor pins.

**Figure 9. Generic Clock Waveform**

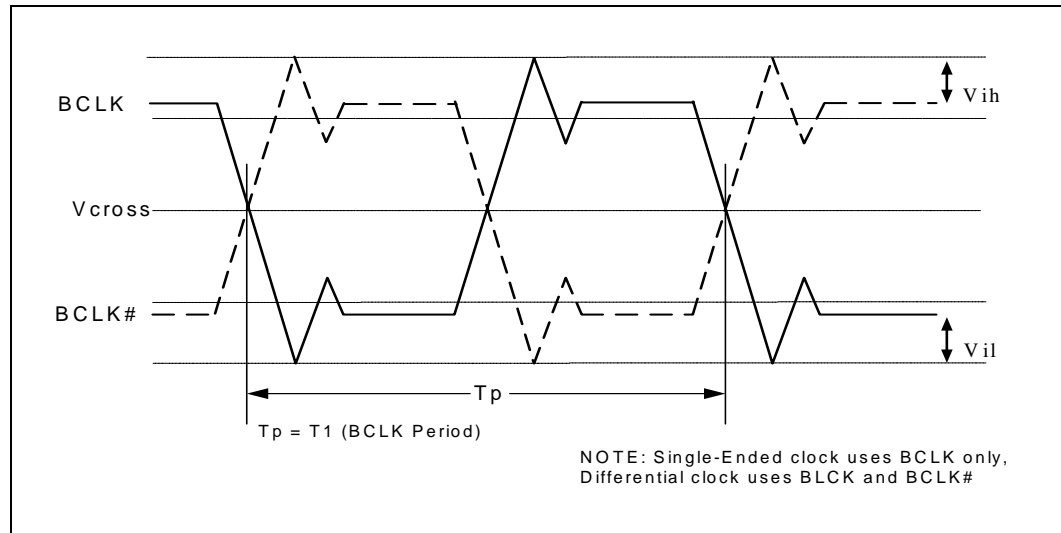

Figure 10. BCLK, PICCLK, and TCK Generic Clock Waveform

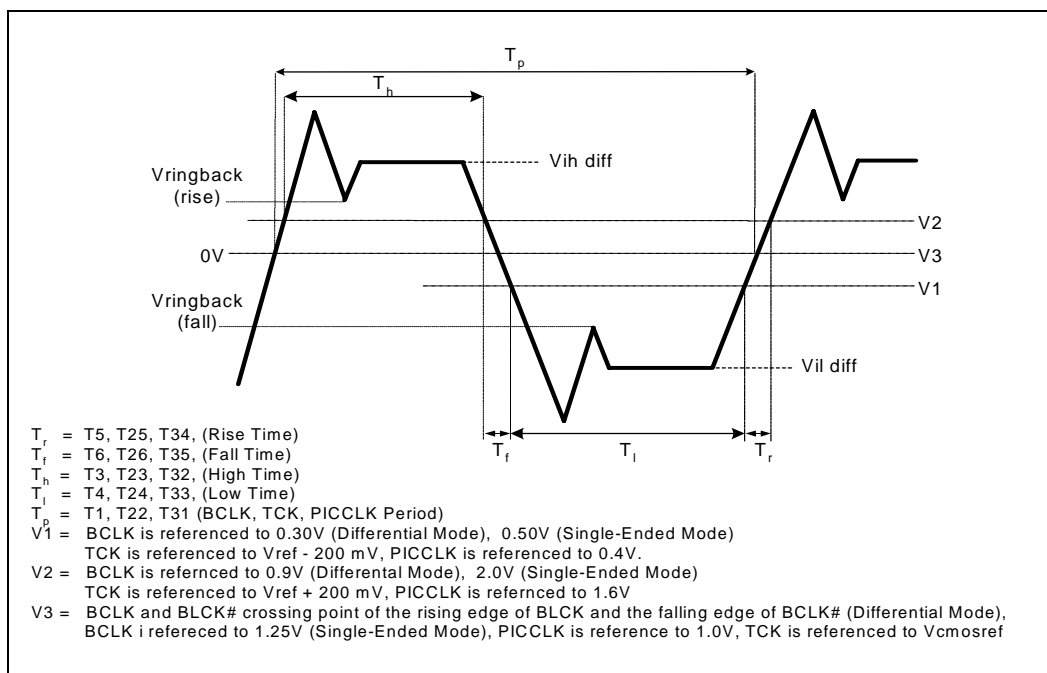

Figure 11. System Bus Valid Delay Timings

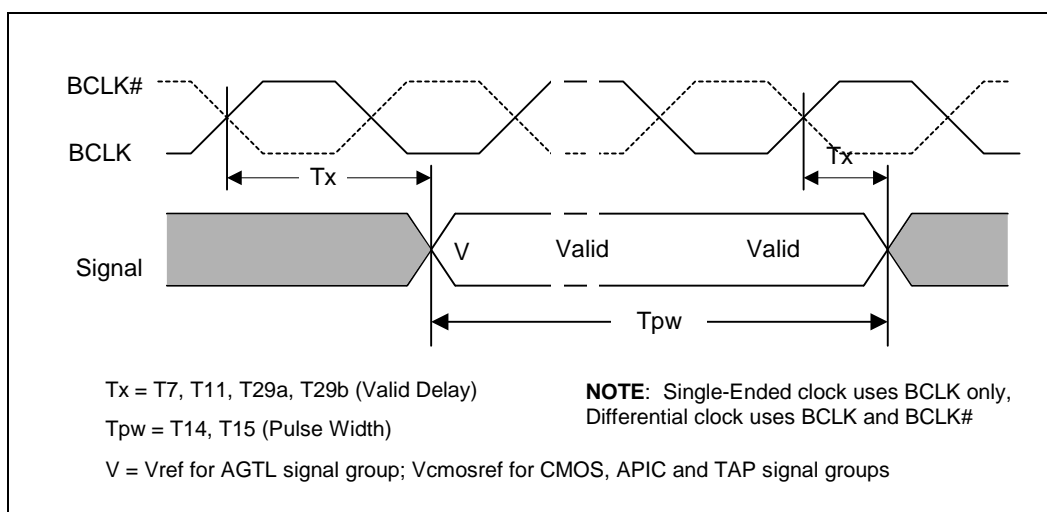

Figure 12. System Bus Setup and Hold Timings

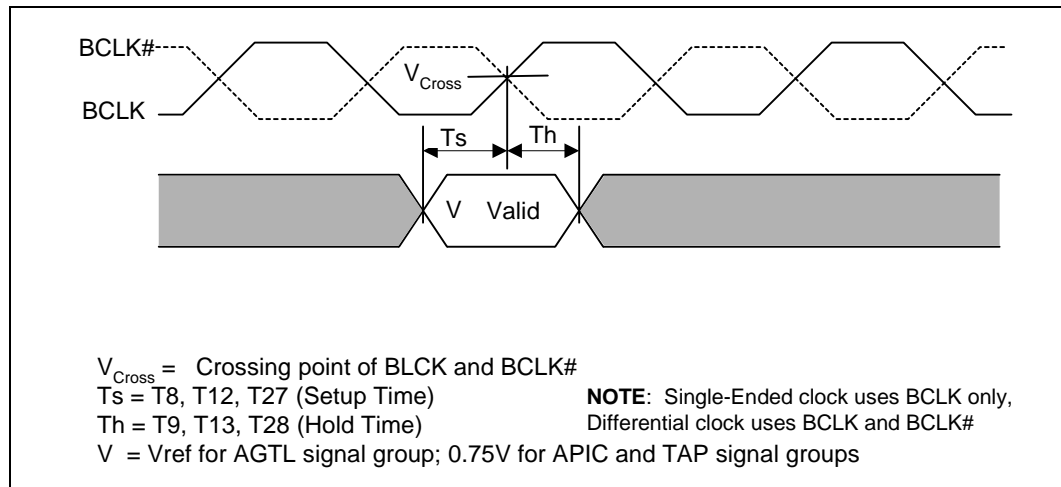

Figure 13. System Bus Reset and Configuration Timings

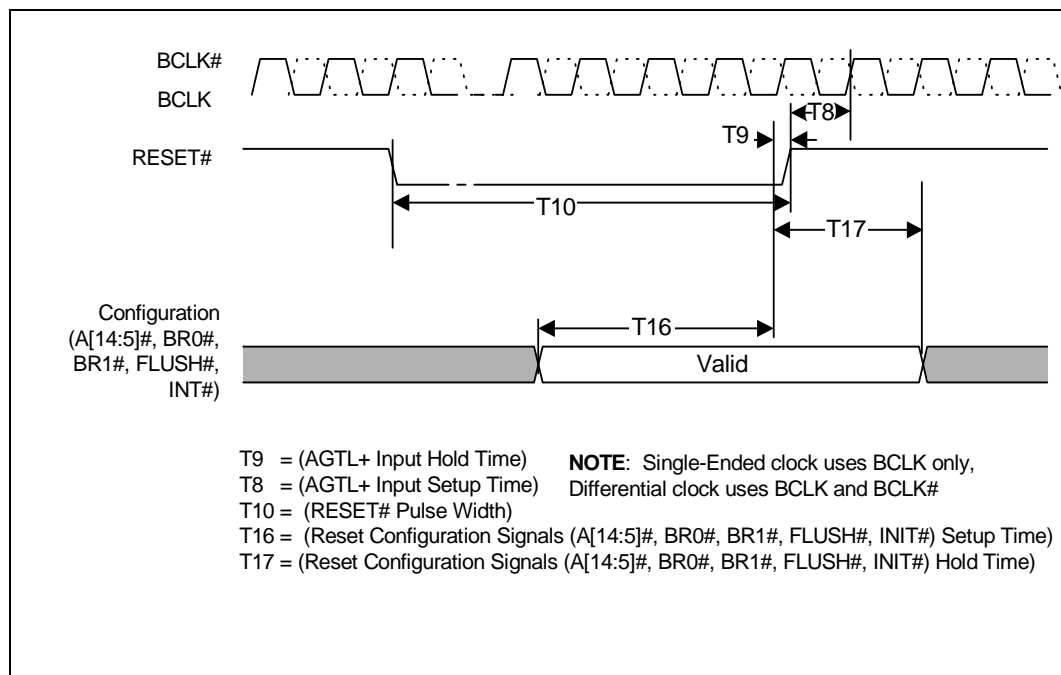

Figure 14. Platform Power-On Sequence Timings

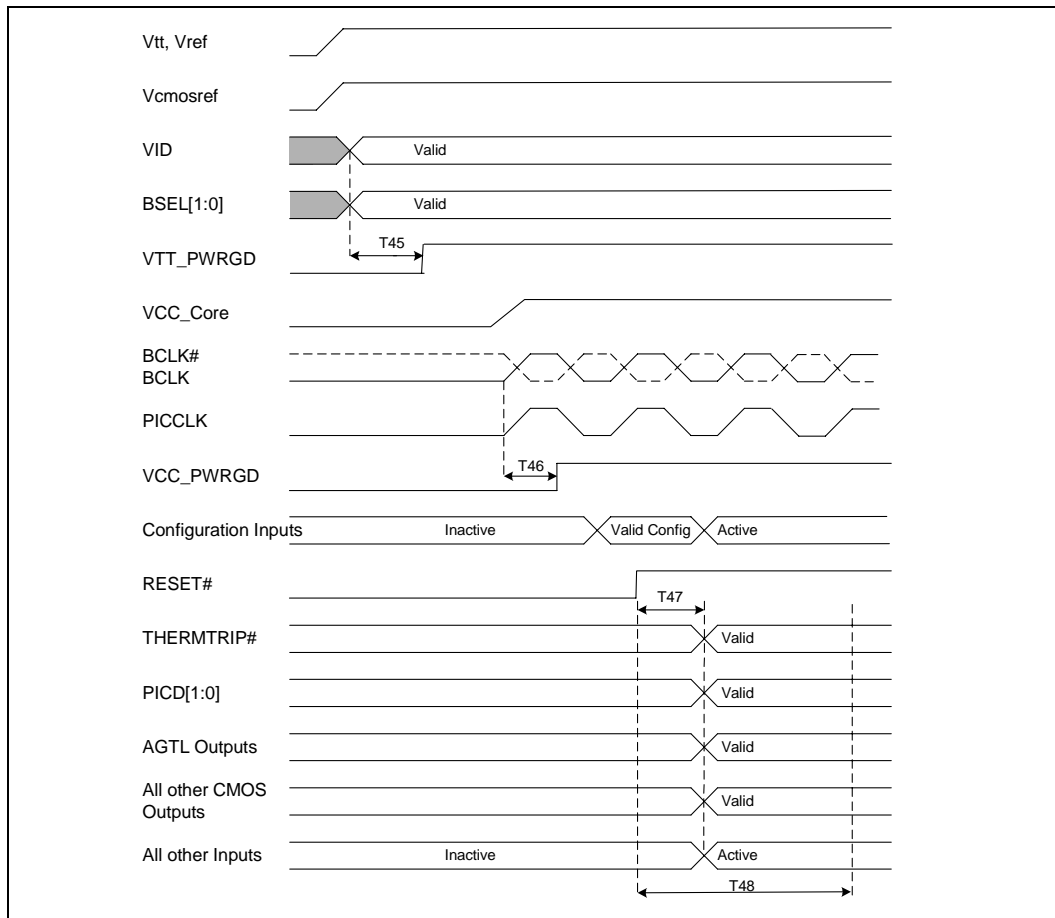
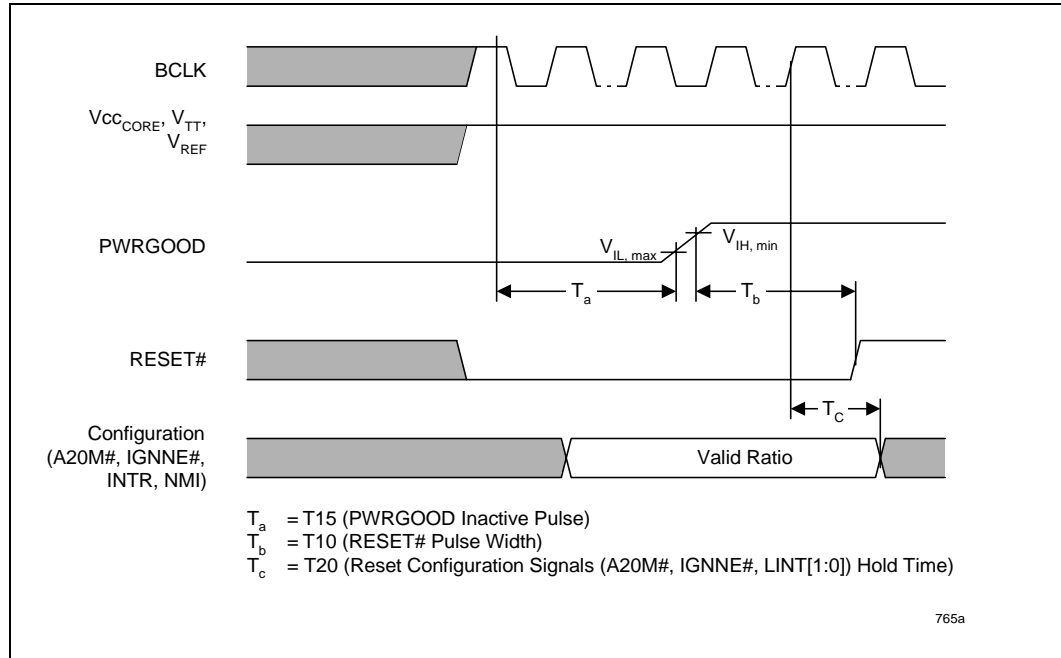

Figure 15. Power-On Reset and Configuration Timings



## 3.0 Signal Quality Specifications

Signals driven on the processor system bus should meet signal quality specifications to ensure that the components read data properly and to ensure that incoming signals do not affect the long term reliability of the component. Specifications are provided for simulation at the processor pins. Meeting the specifications at the processor pins in [Table 21](#), [Table 22](#), [Table 23](#), [Table 24](#), and [Table 25](#) ensures that signal quality effects will not adversely affect processor operation.

### 3.1 BCLK/BCLK# and PICCLK Signal Quality Specifications and Measurement Guidelines

[Table 21](#) describes the signal quality specifications at the processor pins for the processor system bus clock (BCLK) and APIC clock (PICCLK) signals. [Figure 16](#) describes the signal quality waveform for the system bus clock at the processor pins.

**Table 21. BCLK/PICCLK Signal Quality Specifications for Simulation at the Processor Pins <sup>1</sup>**

T# Parameter	Min	Nom	Max	Unit	Figure	Notes
V1: BCLK V <sub>IL</sub>			0.500	V	16	
V1: PICCLK V <sub>IL</sub>			0.700	V	16	
V2: BCLK V <sub>IH</sub>	2.000			V	16	
V2: PICCLK V <sub>IH</sub>	2.000			V	16	
V3: V <sub>IN</sub> Absolute Voltage Range	-0.58		3.18	V	16	
V4: BCLK Rising Edge Ringback	2.000			V	16	2
V4: PICCLK Rising Edge Ringback	2.000			V	16	2
V5: BCLK Falling Edge Ringback			0.500	V	16	2
V5: PICCLK Falling Edge Ringback			0.700	V	16	2

**NOTES:**

1. Unless otherwise noted, all specifications in this table apply to all Pentium III processors frequencies.
2. The rising and falling edge ringback voltage specified is the minimum (rising) or maximum (falling) absolute voltage the BCLK/PICCLK signal can dip back to after passing the V<sub>IH</sub> (rising) or V<sub>IL</sub> (falling) voltage limits. This specification is an absolute value.

**Table 22. BCLK/PICCLK Signal Quality Specifications for Simulation at the Processor Pins in a Differential Clock Platform for AGTL**

T# Parameter	Min	Nom	Max	Unit	Figure	Notes
V1: PICCLK V <sub>IL</sub>			0.40	V	16	
V2: PICCLK V <sub>IH</sub>	1.60			V	16	
V3: PICCLK Absolute Voltage Range	-0.4		2.4	V	16	
V4: PICCLK Rising Edge Ringback	1.60			V	16	2
V5: PICCLK Falling Edge Ringback			0.40	V	16	2

**NOTES:**

1. Unless otherwise noted, all specifications in this table apply to Pentium III processors that support the AGTL specification. Refer to the *Intel® Pentium® III Processor Specification Update* for a complete listing on the processors that support the AGTL specification.

- The rising and falling edge ringback voltage specified is the minimum (rising) or maximum (falling) absolute voltage the BCLK/PICCLK signal can dip back to after passing the  $V_{IH}$  (rising) or  $V_{IL}$  (falling) voltage limits. This specification is an absolute value.

Figure 16. BCLK, PICCLK Generic Clock Waveform at the Processor Pins

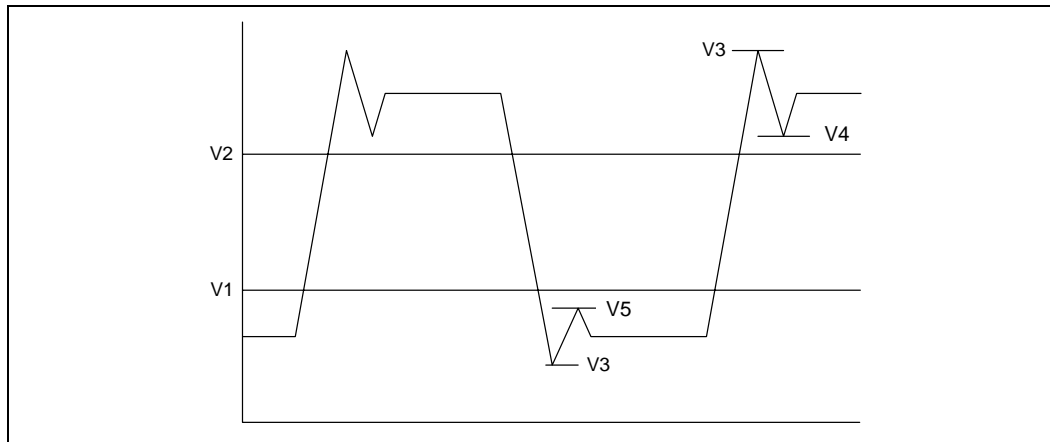

### 3.2 AGTL+ / AGTL Signal Quality Specifications and Measurement Guidelines

Many scenarios have been simulated to generate a set of AGTL+ layout guidelines which are available in the appropriate platform design guide. Refer to the *Intel® Pentium® II Processor Developer's Manual* (Order Number 243502) for the AGTL+/AGTL buffer specification.

Table 23 provides the AGTL+ signal quality specifications for the processor for use in simulating signal quality at the processor pins.

The Pentium III processor for the PGA370 socket maximum allowable overshoot and undershoot specifications for a given duration of time are detailed in Table 25 through Table 27. Figure 17 shows the AGTL+/AGTL ringback tolerance and Figure 18 shows the overshoot/undershoot waveform.

Table 23. AGTL+ Signal Groups Ringback Tolerance Specifications at the Processor Pins <sup>1, 2, 3</sup>

T# Parameter	Min	Unit	Figure	Notes
$\alpha$ : Overshoot	100	mV	17	4, 8
$\tau$ : Minimum Time at High	0.50	ns	17	
$\rho$ : Amplitude of Ringback	$\pm 200$	mV	17	5, 6, 7, 8
$\phi$ : Final Settling Voltage	200	mV	17	8
$\delta$ : Duration of Squarewave Ringback	N/A	ns	17	

**NOTES:**

- Unless otherwise noted, all specifications in this table apply to all Pentium III processors frequencies.
- Specifications are for the edge rate of 0.3 - 0.8V/ns. See Figure 17 for the generic waveform.
- All values specified by design characterization.
- Please see Table 25 for maximum allowable overshoot.
- Ringback between  $V_{REF} + 100$  mV and  $V_{REF} + 200$  mV or  $V_{REF} - 200$  mV and  $V_{REF} - 100$  mVs requires the flight time measurements to be adjusted as described in the Intel AGTL+ Specifications (*Intel® Pentium® II Developers Manual*). Ringback below  $V_{REF} + 100$  mV or above  $V_{REF} - 100$  mV is not supported.

6. Intel recommends simulations not exceed a ringback value of  $V_{REF} \pm 200$  mV to allow margin for other sources of system noise.
7. A negative value for  $\rho$  indicates that the amplitude of ringback is above  $V_{REF}$ . (i.e.,  $\phi = -100$  mV specifies the signal cannot ringback below  $V_{REF} + 100$  mV).
8.  $\phi$  and  $\rho$  are measured relative to  $V_{REF}$ .  $\alpha$  is measured relative to  $V_{REF} + 200$  mV.

Figure 17. Low to High AGTL+ Receiver Ringback Tolerance

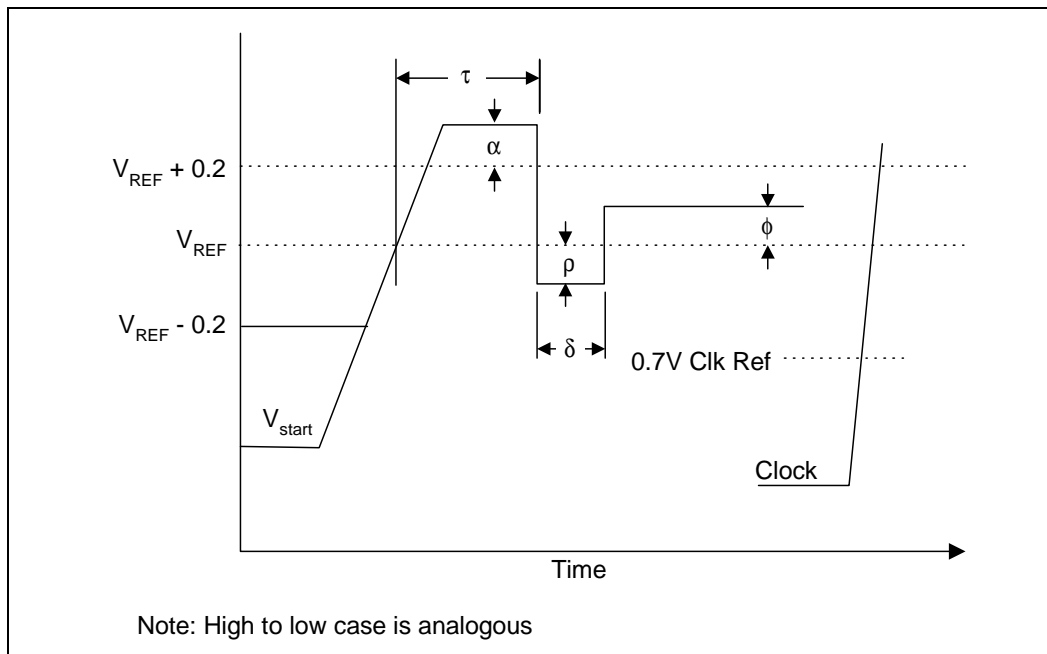

### 3.3 AGTL+ Signal Quality Specifications and Measurement Guidelines

#### 3.3.1 Overshoot/Undershoot Guidelines

Overshoot (or undershoot) is the absolute value of the maximum voltage above the nominal high voltage or below  $V_{SS}$ . The overshoot guideline limits transitions beyond  $V_{CC}$  or  $V_{SS}$  due to the fast signal edge rates. The processor can be damaged by repeated overshoot events on 1.5 V or 2.5 V tolerant buffers if the charge is large enough (i.e., if the overshoot is great enough). Determining the impact of an overshoot/undershoot condition requires knowledge of the magnitude, the pulse direction and the activity factor (AF). Permanent damage to the processor is the likely result of excessive overshoot/undershoot. Violating the overshoot/undershoot guideline will also make satisfying the ringback specification difficult.

When performing simulations to determine impact of overshoot and overshoot, ESD diodes must be properly characterized. ESD protection diodes do not act as voltage clamps and will not provide overshoot or undershoot protection. ESD diodes modeled within Intel I/O Buffer models do not clamp undershoot or overshoot and will yield correct simulation results. If other I/O buffer models are being used to characterize the Pentium III processor performance, care must be taken to ensure that ESD models do not clamp extreme voltage levels. Intel I/O Buffer models also contain I/O capacitance characterization. Therefore, removing the ESD diodes from an I/O Buffer model will impact results and may yield excessive overshoot/undershoot.



### 3.3.2 Overshoot/Undershoot Magnitude

Magnitude describes the maximum potential difference between a signal and its voltage reference level, VSS (overshoot) and VTT (undershoot). While overshoot can be measured relative to VSS using one probe (probe to signal and GND lead to VSS), undershoot must be measured relative to VTT. This could be accomplished by simultaneously measuring the VTT plane while measuring the signal undershoot. Today's oscilloscopes can easily calculate the true undershoot waveform. The true undershoot waveform can also be obtained with the following oscilloscope data file analysis:

$$\text{Converted Undershoot Waveform} = \text{VTT} - \text{Signal\_measured}$$

**Note:** The converted undershoot waveform appears as a positive (overshoot) signal.

**Note:** Overshoot (rising edge) and undershoot (falling edge) conditions are separate and their impact must be determined independently.

After the true waveform conversion, the undershoot/overshoot specifications shown in [Table 25](#) through [Table 27](#) can be applied to the converted undershoot waveform using the same magnitude and pulse duration specifications used with an overshoot waveform.

Overshoot/undershoot magnitude levels must observe the Absolute Maximum Specifications listed in [Table 25](#) through [Table 27](#). These specifications must not be violated at any time regardless of bus activity or system state. Within these specifications are threshold levels that define different allowed pulse durations. Provided that the magnitude of the overshoot/undershoot is within the Absolute Maximum Specifications (2.18V), the pulse magnitude, duration and activity factor must all be used to determine if the overshoot/undershoot pulse is within specifications.

### 3.3.3 Overshoot/Undershoot Pulse Duration

Pulse duration describes the total time an overshoot/undershoot event exceeds the overshoot/undershoot reference voltage ( $V_{os\_ref} = 1.635 \text{ V}$ ). The total time could encompass several oscillations above the reference voltage. Multiple overshoot/undershoot pulses within a single overshoot/undershoot event may need to be measured to determine the total pulse duration.

**Note:** Oscillations below the reference voltage cannot be subtracted from the total overshoot/undershoot pulse duration.

**Note:** Multiple Overshoot/Undershoot events occurring within the same clock cycle must be considered together as one event. Using the worst case Overshoot/Undershoot Magnitude, sum together the individual Pulse Durations to determine the total Overshoot/Undershoot Pulse Duration for that total event.

### 3.3.4 Activity Factor

Activity Factor (AF) describes the frequency of overshoot (or undershoot) occurrence relative to a clock. Since the highest frequency of assertion of an AGTL+ or a CMOS signal is every other clock, an  $AF = 1$  indicates that the specific overshoot (or undershoot) waveform occurs EVERY OTHER clock cycle. Thus, an  $AF = 0.01$  indicates that the specific overshoot (or undershoot) waveform occurs one time in every 200 clock cycles.

The specifications provided in [Table 25](#) through [Table 27](#) show the Maximum Pulse Duration allowed for a given Overshoot/Undershoot Magnitude at a specific Activity Factor. Each Table entry is independent of all others, meaning that the Pulse Duration reflects the existence of overshoot/undershoot events of that magnitude **only**. A platform with an overshoot/undershoot that

just meets the pulse duration for a specific magnitude where the  $AF < 1$ , means that there can be NO other overshoot/undershoot events, even of lesser magnitude (note that if  $AF = 1$ , then the event occurs at all times and no other events can occur).

**Note:** Activity factor for AGTL+ signals is referenced to BCLK frequency.

**Note:** Activity factor for CMOS signals is referenced to PICCLK frequency.

### 3.3.5 Reading Overshoot/Undershoot Specification Tables

The overshoot/undershoot specification for the Pentium III processor for the PGA370 socket is not a simple single value. Instead, many factors are needed to determine what the over/undershoot specification is. In addition to the magnitude of the overshoot, the following parameters must also be known: the junction temperature the processor will be operating at, the width of the overshoot (as measured above 1.635 V) and the Activity Factor (AF). To determine the allowed overshoot for a particular overshoot event, the following must be done:

1. Determine the signal group that particular signal falls into. If the signal is an AGTL+ signal operating with a 100 MHz system bus, use [Table 25](#) (100MHz AGTL+ signal group). If the signal is an AGTL+ signal operating with a 133MHz system bus, use [Table 26](#) (133 MHz AGTL+ signal group). If the signal is a CMOS signal, use [Table 27](#) (33 MHz CMOS signal group).
2. Determine the maximum junction temperature ( $T_j$ ) for the range of processors that the system will support (80°C or 85°C).
3. Determine the Magnitude of the overshoot (relative to  $V_{SS}$ )
4. Determine the Activity Factor (how often does this overshoot occur?)
5. From the appropriate Specification table, read off the Maximum Pulse Duration (in ns) allowed.
6. Compare the specified Maximum Pulse Duration to the signal being measured. If the Pulse Duration measured is less than the Pulse Duration shown in the table, then the signal meets the specifications.

The above procedure is similar for undershoots after the undershoot waveform has been converted to look like an overshoot. Undershoot events must be analyzed separately from Overshoot events as they are mutually exclusive.

Below is an example showing how the maximum pulse duration is determined for a given waveform.

**Table 24. Example Platform Information**

Required Information	Maximum Platform Support	Notes
FSB Signal Group	133 MHz AGTL+	
Max $T_j$	85 °C	
Overshoot Magnitude	2.13V	Measured Value
Activity Factor (AF)	0.1	Measured overshoot occurs on average every 20 clocks

**NOTES:**

1. Corresponding Maximum Pulse Duration Specification - 2.4 ns
2. Pulse Duration (measured) - 2.0 ns

Given the above parameters, and using [Table 26](#) (85 °C/AF = 0.1 column) the maximum allowed pulse duration is 2.4 ns. Since the measure pulse duration is 2.0 ns, this particular overshoot event passes the overshoot specifications, although this doesn't guarantee that the combined overshoot/undershoot events meet the specifications.

### 3.3.6 Determining if a System Meets the Overshoot/Undershoot Specifications

The overshoot/undershoot specifications listed in the following tables specify the allowable overshoot/undershoot for a single overshoot/undershoot event. However most systems will have multiple overshoot and/or undershoot events that each have their own set of parameters (duration, AF and magnitude). While each overshoot on its own may meet the overshoot specification, when you add the total impact of all overshoot events, the system may fail. A guideline to ensure a system passes the overshoot and undershoot specifications is shown below. It is important to meet these guidelines; otherwise, contact your Intel field representative.

1. Insure no signal (CMOS or AGTL+/AGTL) ever exceed the 1.635 V

OR

2. If only one overshoot/undershoot event magnitude occurs, ensure it meets the over/undershoot specifications in the following tables

OR

3. If multiple overshoots and/or multiple undershoots occur, measure the worst case pulse duration for each magnitude and compare the results against the AF = 1 specifications. If all of these worst case overshoot or undershoot events meet the specifications (measured time < specifications) in the table (where AF=1), then the system passes.

The following notes apply to [Table 25](#) through [Table 27](#).

**NOTES:**

1. Overshoot/Undershoot Magnitude = 2.18 V is an Absolute value and should never be exceeded
2. Overshoot is measured relative to VSS.
3. Undershoot is measured relative to VTT
4. Overshoot/Undershoot Pulse Duration is measured relative to 1.635 V.
5. Ringbacks below VTT can not be subtracted from Overshoots/Undershoots
6. Lesser Undershoot does not allocate longer or larger Overshoot
7. OEM's are encouraged to follow Intel provided layout guidelines. Consult the layout guidelines provided in the specific platform design guide.
8. All values specified by design characterization

**Table 25. 100 MHz AGTL+ / AGTL Signal Group Overshoot/Undershoot Tolerance at Processor Pins<sup>1,2</sup>**

Overshoot/ Undershoot Magnitude	Maximum Pulse Duration at Tj = 80 °C (ns)			Maximum Pulse Duration at Tj = 85 °C (ns)		
	AF = 0.01	AF = 0.1	AF = 1	AF = 0.01	AF = 0.1	AF = 1
2.18 V	20	2.53	0.25	18.6	1.86	0.18
2.13 V	20	4.93	0.49	20	3.2	0.32
2.08 V	20	9.1	0.91	20	6.1	0.6
2.03 V	20	16.6	1.67	20	11.4	1.1
1.98 V	20	20	3.0	20	20	2
1.93 V	20	20	5.5	20	20	6.6
1.88 V	20	20	10	20	20	20

**NOTES:**

1. BCLK period is 10 ns.
2. Measurements taken at the processor socket pins on the solder-side of the motherboard.

Table 26. 133 MHz AGTL+/AGTL Signal Group Overshoot/Undershoot Tolerance<sup>1, 2</sup>

Overshoot/Undershoot Magnitude	Maximum Pulse Duration at Tj = 80 °C (ns)			Maximum Pulse Duration at Tj = 85 °C (ns)		
	AF = 0.01	AF = 0.1	AF = 1	AF = 0.01	AF = 0.1	AF = 1
2.18 V	15	1.9	0.19	14	1.4	0.14
2.13 V	15	3.7	0.37	15	2.4	0.24
2.08 V	15	6.8	0.68	15	4.6	0.46
2.03 V	15	12.5	1.25	15	8.6	0.84
1.98 V	15	15	2.28	15	15	1.5
1.93 V	15	15	4.1	15	15	5
1.88 V	15	15	7.5	15	15	15

**NOTES:**

1. BCLK period is 7.5 ns.
2. Measurements taken at the processor socket pins on the solder-side of the motherboard.

Table 27. 33 MHz CMOS Signal Group Overshoot/Undershoot Tolerance at Processor Pins<sup>1, 2</sup>

Overshoot/Undershoot Magnitude	Maximum Pulse Duration at Tj = 80 °C (ns)			Maximum Pulse Duration at Tj = 85 °C (ns)		
	AF = 0.01	AF = 0.1	AF = 1	AF = 0.01	AF = 0.1	AF = 1
2.18 V	60	7.6	0.76	56	5.6	0.56
2.13 V	60	14.8	1.48	60	9.6	0.96
2.08 V	60	27.2	2.7	60	18.4	1.8
2.03 V	60	50	5	60	33	3.3
1.98 V	60	60	9.1	60	60	6
1.93 V	60	60	16.4	60	60	20
1.88 V	60	60	30	60	60	60

**NOTES:**

1. PICCLK period is 30 ns.
2. Measurements taken at the processor socket pins on the solder-side of the motherboard.

Figure 18. Maximum Acceptable AGTL+ Overshoot/Undershoot Waveform

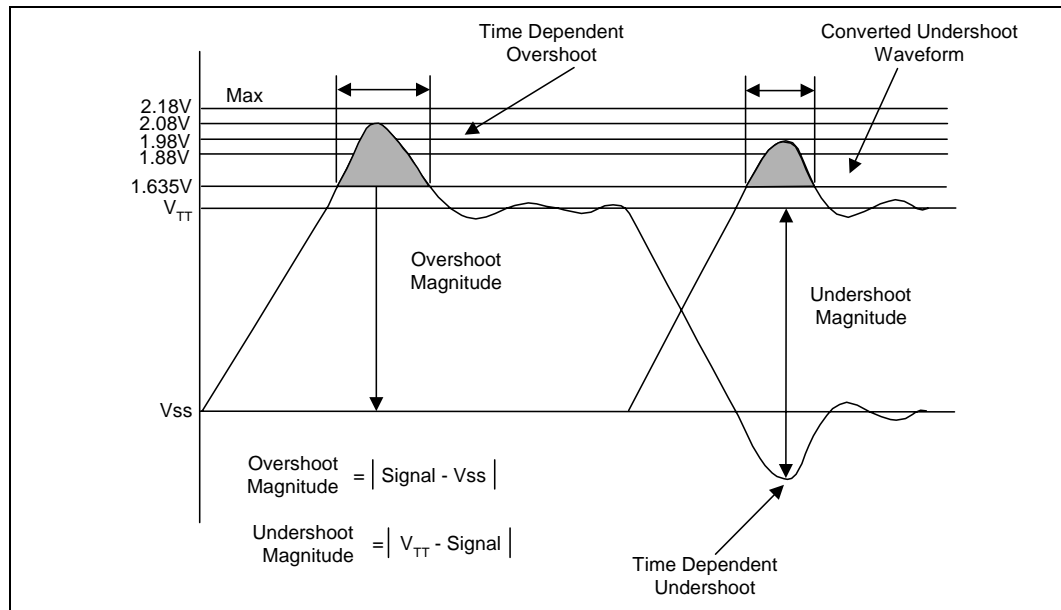
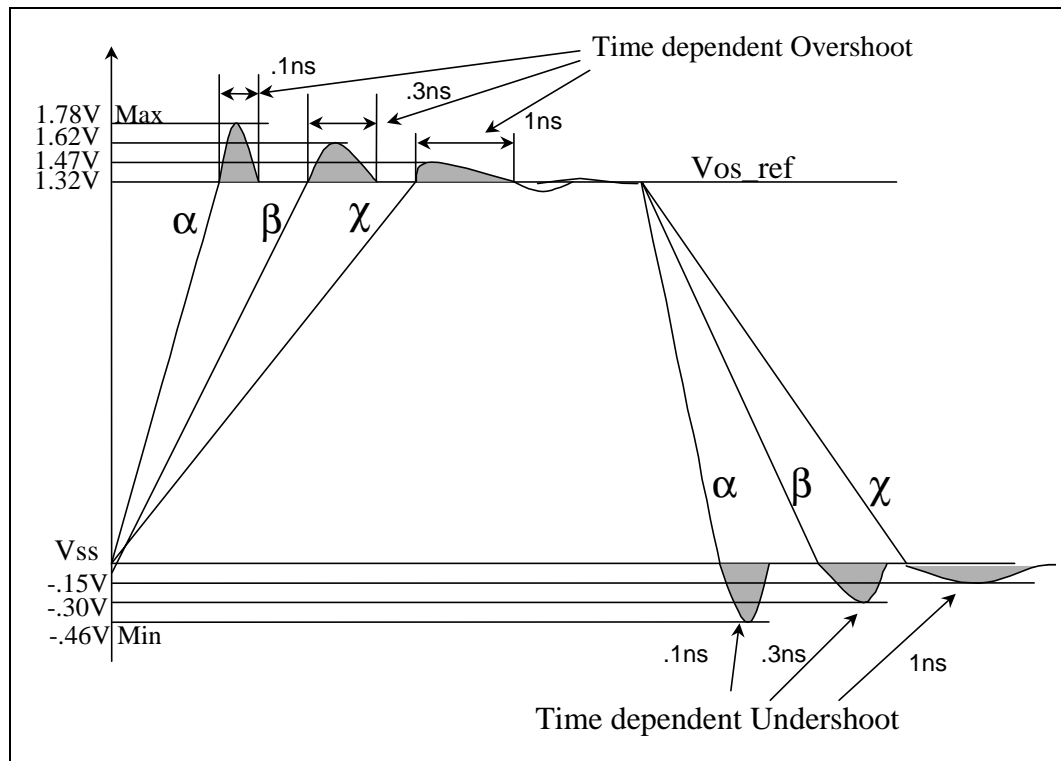

Figure 19. Maximum Acceptable AGTL Overshoot/Undershoot Waveform



### 3.4 Non-AGTL+ (Non-AGTL) Signal Quality Specifications and Measurement Guidelines

There are three signal quality parameters defined for non-AGTL+ signals: overshoot/undershoot, ringback, and settling limit. All three signal quality parameters are shown in Figure 20 for the non-AGTL+ signal group.

Figure 20. Non-AGTL+ (Non-AGTL) Overshoot/Undershoot, Settling Limit, and Ringback <sup>1</sup>

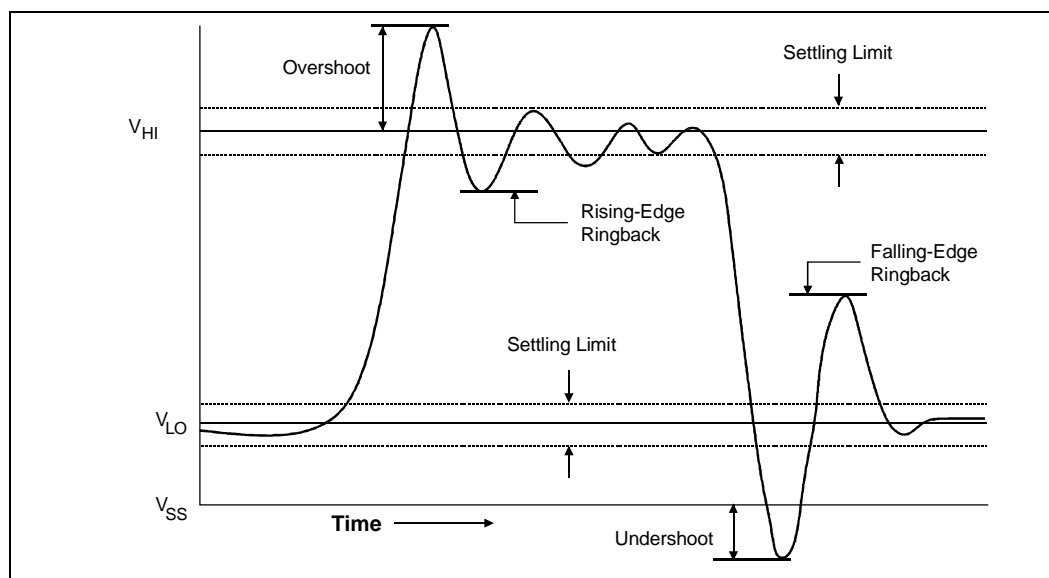

**NOTES:**

1.  $V_{HI} = 1.5$  V for all non-AGTL+ signals except for BCLK, PICCLK, and PWRGOOD.  $V_{HI} = 2.5$  V for BCLK, PICCLK, and PWRGOOD. BCLK and PICCLK signal quality is detailed in Section 3.1.

#### 3.4.1 Overshoot/Undershoot Guidelines

Overshoot (or undershoot) is the absolute value of the maximum voltage above the nominal high voltage or below  $V_{SS}$ . The overshoot guideline limits transitions beyond  $V_{CC}$  or  $V_{SS}$  due to the fast signal edge rates (see Figure 20 for non-AGTL+ signals). The processor can be damaged by repeated overshoot events on 1.5 V or 2.5 V tolerant buffers if the charge is large enough (i.e., if the overshoot is great enough). Permanent damage to the processor is the likely result of excessive overshoot/undershoot. Violating the overshoot/undershoot guideline will also make satisfying the ringback specification difficult. *The overshoot/undershoot guideline is 0.3 V and assumes the absence of diodes on the input. These guidelines should be verified in simulations without the on-chip ESD protection diodes present* because the diodes will begin clamping the 1.5 V and 2.5 V tolerant signals beginning at approximately 0.7 V above the appropriate supply and 0.7 V below  $V_{SS}$ . If signals are not reaching the clamping voltage, this will not be an issue. A system should not rely on the diodes for overshoot/undershoot protection as this will negatively affect the life of the components and make meeting the ringback specification very difficult.

**Note:** The undershoot guideline limits transitions exactly as described for the ATGL+/AGTL signals. See Figure 18.

### 3.4.2 Ringback Specification

Ringback refers to the amount of reflection seen after a signal has switched. The ringback specification is the voltage that the signal rings back to after achieving its maximum absolute value. See Figure 20 for an illustration of ringback. Excessive ringback can cause false signal detection or extend the propagation delay. The ringback specification applies to the input pin of each receiving agent. Violations of the signal ringback specification are not allowed under any circumstances for non-AGTL+ (non-AGTL) signals.

Ringback can be simulated with or without the input protection diodes that can be added to the input buffer model. However, signals that reach the clamping voltage should be evaluated further. See Table for the signal ringback specifications for non-AGTL+ signals for simulations at the processor pins.

**Table 28. Signal Ringback Specifications for Non-AGTL+ Signal Simulations at the Processor Pins<sup>1</sup>**

Input Signal Group	Transition	Maximum Ringback (with Input Diodes Present)	Unit	Figure
Non-AGTL+ Signals <sup>2</sup>	0 → 1	$V_{CMOS\_REF} + 0.200$	V	20
Non-AGTL+ Signals <sup>2</sup>	1 → 0	$V_{CMOS\_REF} - 0.200$	V	20
PWRGOOD	0 → 1	2.00	V	20

**NOTES:**

1. Unless otherwise noted, all specifications in this table apply to all Pentium III processor frequencies.
2. Non-AGTL+ signals except PWRGOOD.

**Table 29. Signal Ringback Specifications for Non-AGTL Signal Simulations at the Processor Pins<sup>1</sup>**

Input Signal Group	Transition	Maximum Ringback (with Input Diodes Present)	Unit	Figure
Non-AGTL+ Signals <sup>2</sup>	0 → 1	$V_{CMOS\_REF} + 0.200$	V	20
Non-AGTL+ Signals <sup>2</sup>	1 → 0	$V_{CMOS\_REF} - 0.300$	V	20
PWRGOOD	0 → 1	2.00 <sup>3</sup>	V	20

**NOTES:**

1. Unless otherwise noted, all specifications in this table apply to all Pentium III processor frequencies.
2. Non-AGTL signals except PWRGOOD.
3. For Coppermine-T with differential clocking, this signal is 1.8 V tolerant.

### 3.4.3 Settling Limit Guideline

Settling limit defines the maximum amount of ringing at the receiving pin that a signal must reach before its next transition. The amount allowed is 10% of the total signal swing ( $V_{HI} - V_{LO}$ ) above and below its final value. A signal should be within the settling limits of its final value, when either in its high state or low state, before it transitions again.

Signals that are not within their settling limit before transitioning are at risk of unwanted oscillations which could jeopardize signal integrity. Simulations to verify settling limit may be done either with or without the input protection diodes present. Violation of the settling limit guideline is acceptable if simulations of 5 to 10 successive transitions do not show the amplitude of the ringing increasing in the subsequent transitions.

## 4.0 Thermal Specifications and Design Considerations

This chapter provides needed data for designing a thermal solution. However, for the correct thermal measuring processes, refer to AP-905, *Intel® Pentium® III Processor Thermal Design Guidelines* (Document Number 245087). The Pentium III processor uses flip chip pin grid array packaging technology and has a **junction** ( $T_{\text{junction}}$ ) or **case** temperature ( $T_{\text{case}}$ ) specified.

### 4.1 Thermal Specifications

Table 30 provides the thermal design power dissipation and maximum temperatures for the Pentium III processor for the PGA370 socket. Systems should design for the highest possible processor power, even if a processor with a lower thermal dissipation is planned. A thermal solution should be designed to ensure the junction temperature never exceeds these specifications.

**Table 30. Intel® Pentium® III Processor Thermal Design Power for the FC-PGA Package<sup>1</sup>**

Processor	Processor Core Frequency (MHz)	System Bus Frequency (MHz)	Processor Thermal Design Power <sup>2,3</sup> up to CUID 0686h (W)	Processor Thermal Design Power <sup>2,3</sup> CUID 068Ah (W)	Power Density <sup>5</sup> for CUID 068Ah (W/cm <sup>2</sup> )	Maximum $T_{\text{JUNCTION}}$ <sup>10</sup> (°C)	$T_{\text{JUNCTION}}$ Offset for Latest Stepping <sup>4,6</sup> (°C)
500E	500	100	13.2	N/A	N/A	85	1.9
533EB	533	133	14.0	N/A	N/A	85	2.0
550E	550	100	14.5	N/A	N/A	85	2.1
600E	600	100	15.8	19.6	30.5	82	2.6
600EB	600	133	15.8	N/A	N/A	82	2.3
650	650	100	17.0	N/A	N/A	82	2.7
667	667	133	17.5	N/A	N/A	82	2.8
700	700	100	18.3	21.9	34.1	80	2.9
733	733	133	19.1	22.8	35.5	80	3.0
750	750	100	19.5	23.2	36.1	80	3.0
800	800	100	20.8	24.5	38.2	80	3.2
800EB	800	133	20.8	24.5	38.2	80	3.2
850	850	100	22.5	25.7	40.0	80	3.4
866	866	133	22.9	26.1	40.7	80	3.4
900	900	100	23.2	26.7	41.6	77	3.5
933	933	133	24.5	27.5	42.8	77	3.6
1 GHz	1000	100	N/A	29.0	45.2	75 <sup>8</sup>	3.8
1B GHz	1000	133	26.1	29.0	45.2	70 <sup>9</sup>   75 <sup>8</sup>	3.8
1B GHz <sup>7</sup>	1000	133	29.6	N/A	N/A	70	3.9
1.10 GHz	1100	100	N/A	33.0	51.4	77	4.4

**NOTES:**

1. These values are specified at nominal  $V_{\text{CC CORE}}$  for the processor pins.



2. Thermal Design Power (TDP) represents the maximum amount of power the thermal solution is required to dissipate. The thermal solution should be designed to dissipate the TDP power without exceeding the maximum T<sub>junction</sub> specification.
3. TDP does not represent the power delivery and voltage regulation requirements for the processor. Refer to Table 6 for voltage regulation and electrical specifications.
4. T<sub>junctionoffset</sub> is the worst-case difference between the thermal reading from the on-die thermal diode and the hottest location on the processor's core.
5. Power density is the maximum power the processor die can dissipate (i.e., processor power) divided by the die area over which the power is generated. Power for these processors is generated from the core area shown in Figure 21.
6. T<sub>JUNCTION</sub> offset values do not include any thermal diode kit measurement error. Diode kit measurement error must be added to the T<sub>JUNCTION</sub> offset value from the table, as outlined in the *Intel® Pentium® III processor Thermal Metrology for CPUID-068h Family Processors* (Order Number: 245301). Intel has characterized the use of the Analog Devices AD1021 diode measurement kit and found its measurement error to be 1 °C.
7. This specification only applies to 1B GHz S-Spec #: SL4WM. This part has a VID request of 1.70 V, however the processor should be supplied 1.76 V at the PGA Vcc pins by the VRM (Voltage Regulator Module) or by the voltage regulator circuit.
8. This specification applies to processors with CPUID 068AH. 1B GHz exists in both FC-PGA and FC-PGA2 packages.
9. This specification applies to processors with CPUID 0686H.
10. T<sub>junction</sub> minimum specification is 0 °C.

Table 31 provides the thermal design power dissipation and maximum temperatures for the Pentium III processor for the FC-PGA2 package. Systems should design for the highest possible processor power, even if a processor with a lower thermal dissipation is planned. A thermal solution should be designed to ensure the case temperature never exceeds these specifications.

**Table 31. Intel® Pentium® III Processor for the FC-PGA2 Package Thermal Design Power <sup>1</sup>**

Processor	Processor Core Frequency (MHz)	System Bus Frequency (MHz)	Processor Thermal Design Power <sup>2,3</sup> CPUID 068Ah (W)	Maximum T <sub>case</sub> <sup>4</sup> (°C)	Additional Notes
866	866	133	29.5	70	5
933	933	133	31.5	72	5
1B GHz	1000	133	33.9	69	5
1.13 GHz	1133	133	37.5	72	

**NOTES:**

1. These values are specified at nominal V<sub>CC</sub>CORE for the processor pins.
2. Thermal Design Power (TDP) represents the maximum amount of power the thermal solution is required to dissipate. The thermal solution should be designed to dissipate the TDP power without exceeding the maximum T<sub>case</sub> specification.
3. TDP does not represent the power delivery and voltage regulation requirements for the processor. Refer to Table 7 for voltage regulation and electrical specifications.
4. T<sub>CaseOffset</sub> is the worst-case difference between the maximum case temperature and the thermal diode temperature on the processor's core. For more information please refer to the document, *Intel® Pentium® III Processor in the FC-PGA2 Package Thermal Design Guide*.
5. This processor exists in both FC-PGA and FC-PGA2 packages.

## 4.2 Processor Die Area

Figure 21 is a block diagram of the Pentium III processor die layout and Table 32 contains Pentium III processor die layout measurements. The layout differentiates the processor core from the cache die area. In effect, the thermal design power identified in Table 30 is dissipated entirely from the processor core area. Thermal solution designs should compensate for this smaller heat flux area and not assume that the power is uniformly distributed across the entire die area.

Figure 21. Processor Functional Die Layout for FC-PGA

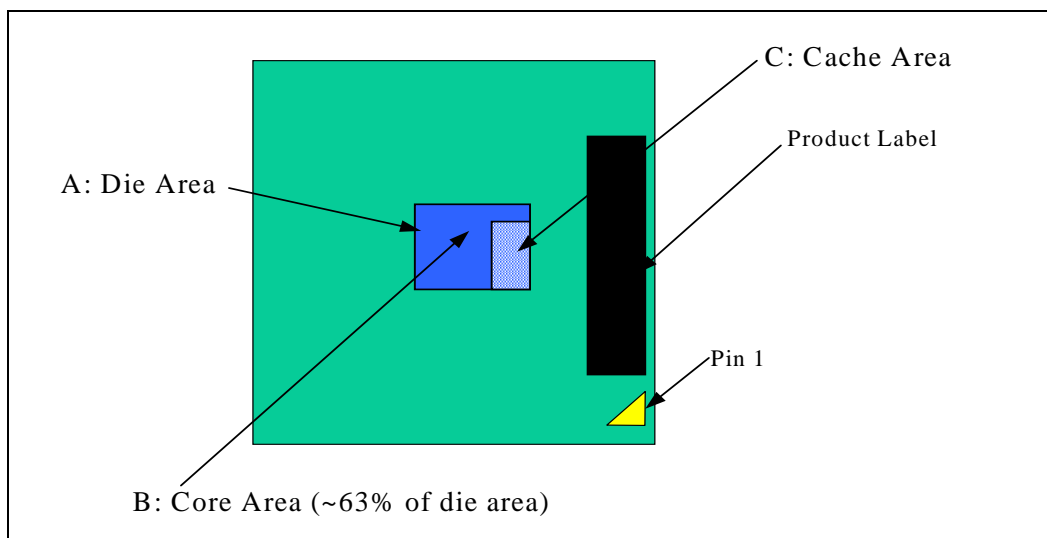

Table 32. Processor Functional Die Layout for FC-PGA

CPUID	A: Die Area (cm <sup>2</sup> )	B: Core Area (cm <sup>2</sup> )	C: Cache Area (cm <sup>2</sup> )
0683H	1.046	0.726	0.320
0686H	0.900	0.642	0.258
068AH	0.947	0.642	0.305

### 4.3 Thermal Diode

The Pentium III processor for the PGA370 socket incorporates an on-die diode that may be used to monitor the die temperature (junction temperature). A thermal sensor located on the motherboard, or a stand-alone measurement kit, may monitor the die temperature of the processor for thermal management or instrumentation purposes. Table 33 and Table 34 provide the diode parameter and interface specifications. For more information please refer to the document, *Intel® Pentium® III Processor in the FC-PGA2 Package Thermal Design Guide*.

**Note:** The reading of the thermal sensor connected to the thermal diode will not necessarily reflect the temperature of the hottest location on the die. This is due to inaccuracies in the thermal sensor, on-die temperature gradients between the location of the thermal diode and the hottest location on the die at a given point in time, and time based variations in the die temperature measurement. Time based variations can occur when the sampling rate of the thermal diode (by the thermal sensor) is slower than the rate at which the  $T_{\text{junction}}$  temperature can change.

**Table 33. Thermal Diode Parameters<sup>1</sup>**

Symbol	Parameter	Min	Typ	Max	Unit	Notes
$I_{fw}$	Forward Bias Current	5		300	$\mu A$	1
n	Diode Ideality Factor	1.0057	1.0080	1.0125		2, 3, 4

**NOTES:**

- Intel does not support or recommend operation of the thermal diode under reverse bias.
- Characterized at 100 ° C with a forward bias current of 5  $\mu A$ –300  $\mu A$ .
- The ideality factor, n, represents the deviation from ideal diode behavior as exemplified by the diode equation:  
 $I_{fw} = I_s (e^{(V_d * q) / (n k T)} - 1)$ , where  $I_s$  = saturation current, q = electronic charge,  $V_d$  = voltage across the diode, k = Boltzmann Constant, and T = absolute temperature (Kelvin).
- Not 100% tested. Specified by design characterization.

**Table 34. Thermal Diode Interface**

Pin Name	PGA370 Socket pin #	Pin Description
THERMDP	AL31	diode anode (p_junction)
THERMDN	AL29	diode cathode (n_junction)

## 5.0 Mechanical Specifications

The Pentium III processor uses a FC-PGA and FC-PGA2 package technology. Mechanical specifications for the processor are given in this section. FC-PGA2 contains an Integrated Heat Spreader (IHS) to spread out the heat generated from the die. See [Section 1.1.1](#) for a complete terminology listing.

The processor utilizes a PGA370 socket for installation into the motherboard. Details on the socket are available in the *370-Pin Socket (PGA370) Design Guidelines*.

**Note:** For [Figure 23](#) and [Figure 24](#) the following apply:

1. Unless otherwise specified, the following drawings are dimensioned in inches.
2. All dimensions provided with tolerances are guaranteed to be met for all normal production product.
3. Figures and drawings labeled as “Reference Dimensions” are provided for informational purposes only. Reference dimensions are extracted from the mechanical design database and are nominal dimensions with no tolerance information applied. Reference dimensions are NOT checked as part of the processor manufacturing. Unless noted as such, dimensions in parentheses without tolerances are reference dimensions.
4. Drawings are not to scale.

The following figure with package dimensions is provided to aid in the design of heatsink and clip solutions as well as demonstrate where pin-side capacitors will be located on the processor. [Table 35](#) includes the measurements for these dimensions in both inches and millimeters.

**Figure 22. FC-PGA and FC-PGA2 Package Types**

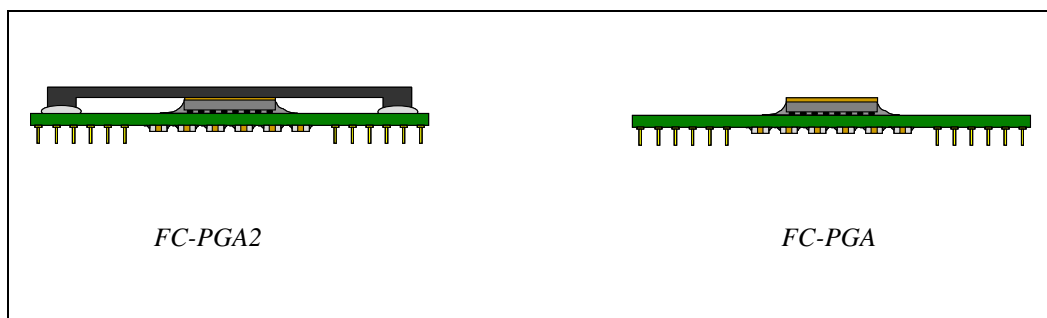

### 5.1 FC-PGA Mechanical Specifications

The following figure with package dimensions is provided to aid in the design of heatsink and clip solutions as well as demonstrate where pin-side capacitors will be located on the processor. [Table 35](#) includes the measurements for these dimensions in both inches and millimeters.

Figure 23. Package Dimensions

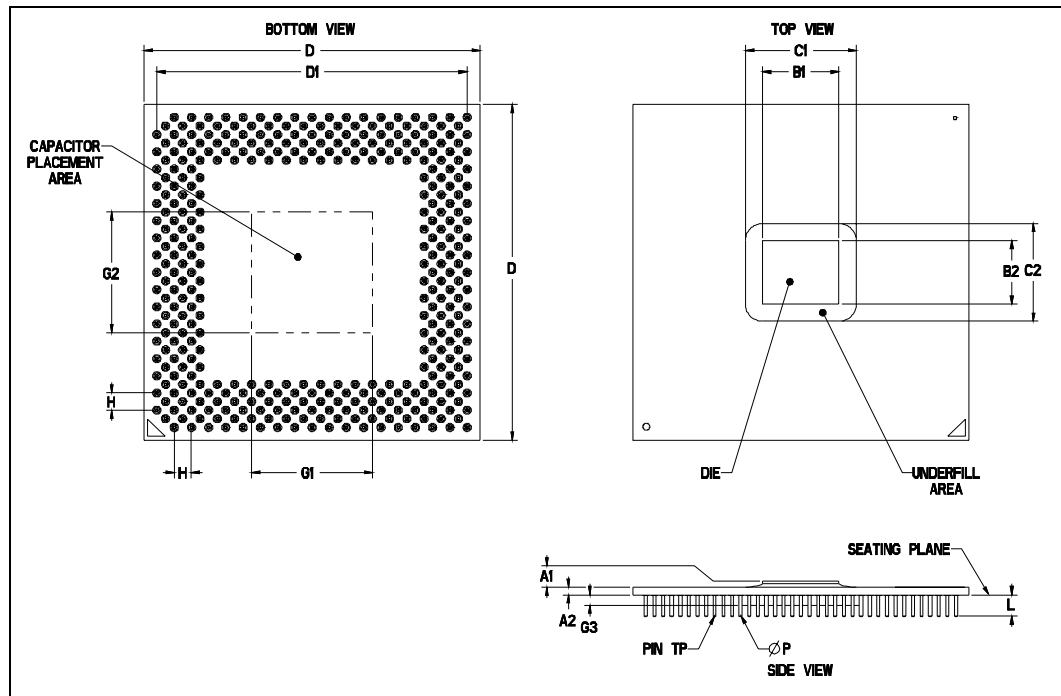

Table 35. Intel® Pentium® III Processor Package Dimensions

Symbol	Millimeters			Inches		
	Minimum	Maximum	Notes	Minimum	Maximum	Notes
A1	0.787	0.889		0.031d	0.035	
A2	1.000	1.200		0.039	0.047	
B1	11.226	11.329		0.442	0.446	
B2	9.296	9.398		0.366	0.370	
C1	23.495 max			0.925 max		
C2	21.590 max			0.850 max		
D	49.428	49.632		1.946	1.954	
D1	45.466	45.974		1.790	1.810	
G1	0.000	17.780		0	0.700	
G2	0.000	17.780		0	0.700	
G3	0.000	0.889		0	0.035	
H	2.540		Nominal	0.100		Nominal
L	3.048	3.302		0.120	0.130	
ΦP	0.431	0.483	Pin Diameter	0.017	0.019	
PIN TP	0.508 Diametric True Position (Pin-to-Pin)			0.020 Diametric True Position (Pin-to-Pin)		

**NOTE:** Capacitors will be placed on the pin-side of the FC-PGA package in the area defined by G1, G2, and G3. This area is a keepout zone for motherboard designers.

The bare processor die has mechanical load limits that should not be exceeded during heat sink assembly, mechanical stress testing, or standard drop and shipping conditions. The heatsink attach solution must not induce permanent stress into the processor substrate with the exception of a uniform load to maintain the heatsink to the processor thermal interface. The package dynamic and static loading parameters are listed in [Table 36](#).

For [Table 36](#), the following apply:

1. It is not recommended to use any portion of the processor substrate as a mechanical reference or load bearing surface for thermal solutions.
2. Parameters assume uniformly applied loads.

**Table 36. Processor Die Loading Parameters for FC-PGA**

Parameter	Dynamic (max) <sup>1</sup>	Static (max) <sup>2</sup>	Unit	Added Notes
Silicon Die Surface	200	50	lbf	3
Silicon Die Edge	100	12	lbf	3

**NOTES:**

1. This specification applies to a uniform and a non-uniform load.
2. This is the maximum static force that can be applied by the heatsink and clip to maintain the heatsink and processor interface.
3. Please see socket manufacturer's force loading specification also to ensure compliance.

### 5.1.1 FC-PGA2 Mechanical Specifications

The following figure is provided to aid in the design of heatsink and clip solutions. Also, it is used to demonstrate where pin-side capacitors will be located on the processor. Table 31 includes the measurements for these dimensions in both inches and millimeters.

Figure 24. Package Dimensions for FC-PGA2

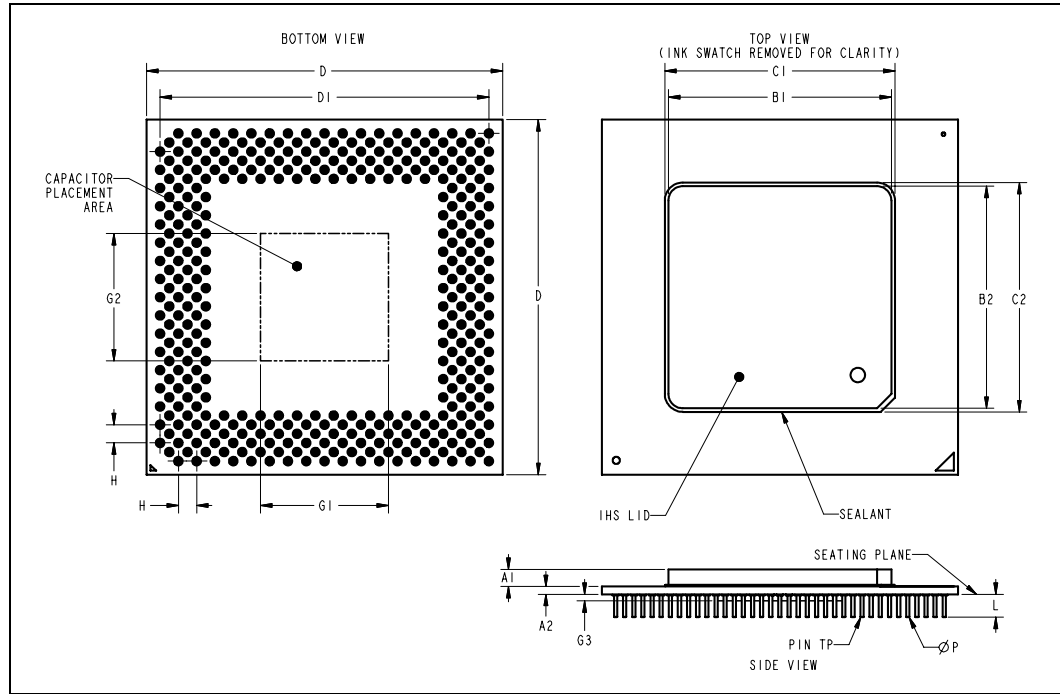

Table 37. Package Dimensions for Intel® Pentium® III Processor FC-PGA2 Package

Symbol	Millimeters			Inches		
	Minimum	Maximum	Notes	Minimum	Maximum	Notes
A1	2.266	2.690		0.089	0.106	
A2	0.980	1.180		0.038	0.047	
B1	30.800	31.200		1.212	1.229	
B2	30.800	31.200		1.212	1.229	
C1	33.000 max			1.299 max		
C2	33.000 max			1.299 max		
D	49.428	49.632		1.946	1.954	
D1	45.466	45.974		1.790	1.810	
G1	0.000	17.780		0.000	0.700	
G2	0.000	17.780		0.000	0.700	
G3	0.000	0.889		0.000	0.035	
H	2.540		Nominal	0.100		Nominal
L	3.048	3.302		0.120	0.130	
ΦP	0.431	0.483		0.017	0.019	

**Table 37. Package Dimensions for Intel® Pentium® III Processor FC-PGA2 Package**

Symbol	Millimeters			Inches		
	Minimum	Maximum	Notes	Minimum	Maximum	Notes
Pin TP	0.508 Diametric True Position (Pin-to-Pin)			0.020 Diametric True Position (Pin-to-Pin)		

**NOTE:** Capacitors will be placed on the pin-side of the FC-PGA package in the area defined by G1, G2, and G3. This area is a keepout zone for motherboard designers.

For Table 38, the following apply:

1. It is not recommended to use any portion of the processor substrate as a mechanical reference or load bearing surface for thermal solutions.
2. Parameters assume uniformly applied loads

**Table 38. Processor Case Loading Parameters for FC-PGA2**

Parameter	Transient (max) <sup>1, 4</sup>	Dynamic (max) <sup>2, 4</sup>	Static (max) <sup>3, 4</sup>	Unit
IHS Surface	200	200	100	lbf
IHS Edge	125	N/A	N/A	lbf
IHS Corner	75	N/A	N/A	lbf

**NOTES:**

1. Transient loading refers to a one time short duration loading, such as during heatsink installation.
2. Dynamic loading refers to a shock load.
3. This is the maximum static force that can be applied by the heatsink and clip to maintain the heatsink and processor interface.
4. Please see socket manufacturer's force loading specification also to ensure compliance. Maximum static loading listed here does not account for the maximum reaction forces on the socket tabs or pins. Designs must ensure that the socket can withstand this force.

**Figure 25. FC-PGA2 Flatness Specification**

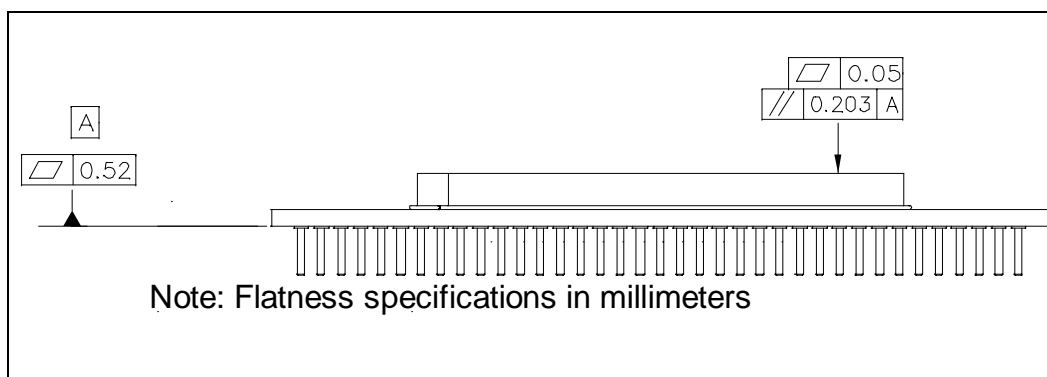



## 5.2 Processor Markings

The following figure exemplifies the processor top-side markings and it is provided to aid in the identification of an Pentium III processor for the PGA370 socket. Table 35 and Table 37 list the measurements for the package dimensions.

Figure 26. Top Side Processor Markings for FC-PGA (up to CPUID 0x686H)

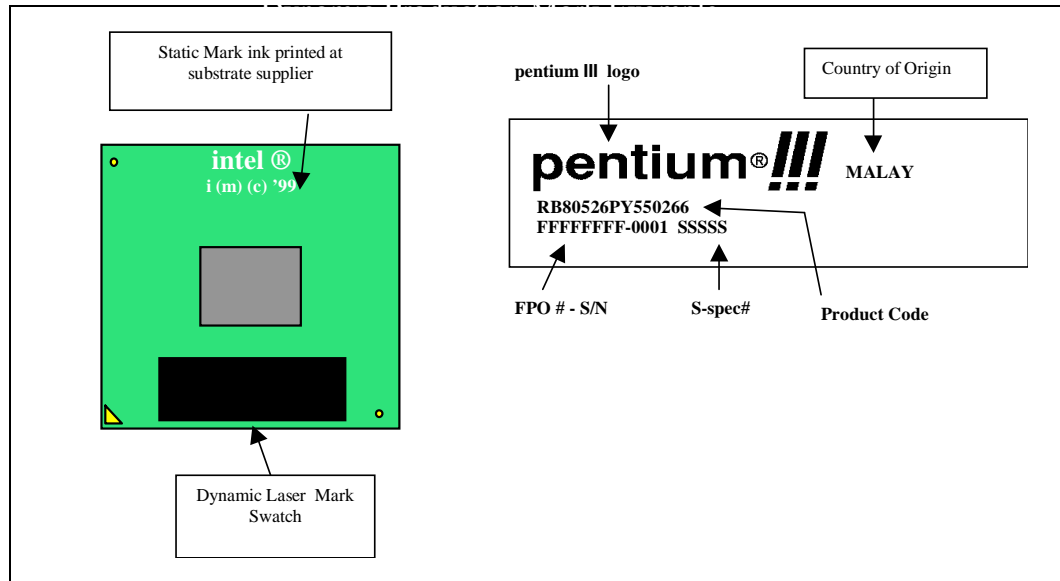
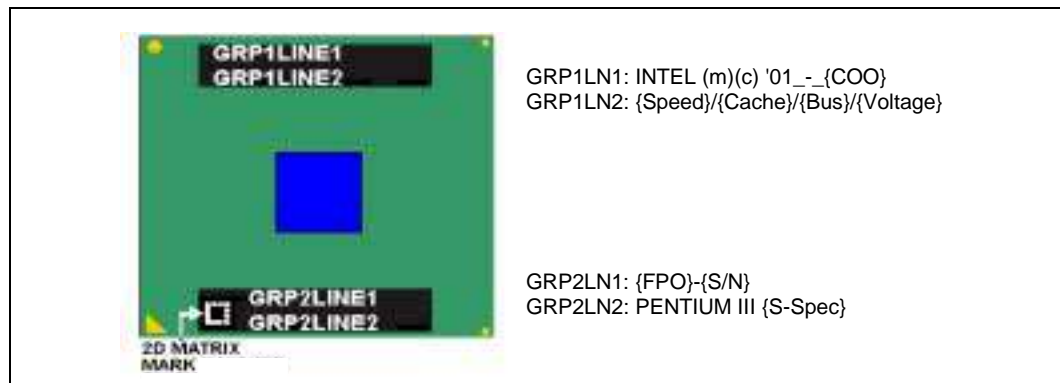

Figure 27. Top Side Processor Markings for FC-PGA (for CPUID 0x68AH)



### 5.2.1 Processor Markings for FC-PGA2

The following figure exemplifies the processor top-side markings and it is provided to aid in the identification of an Pentium III processor for the FC-PGA2 socket. Table 37 lists the measurements for the package dimensions. (Note: this package label will also have a 2D matrix mark.)

Figure 28. Top Side Processor Markings for FC-PGA2

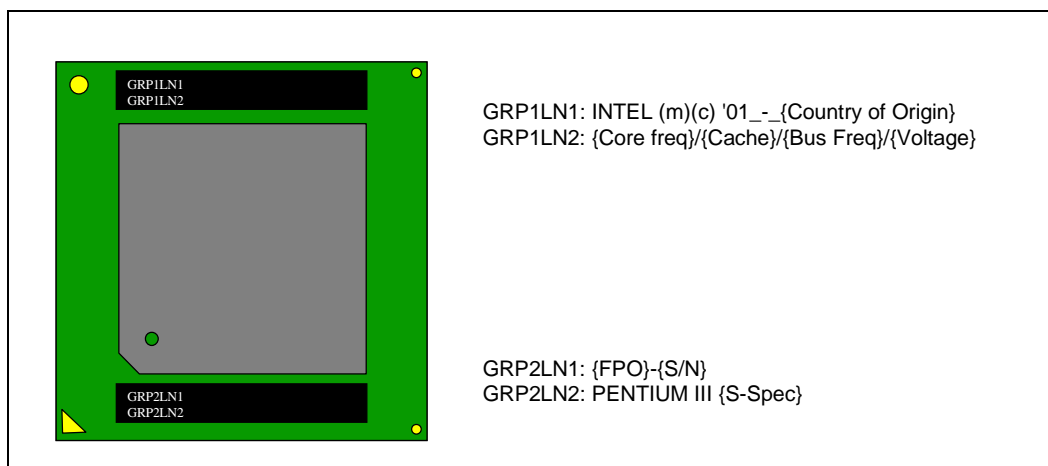

### 5.3 Recommended Mechanical Keep-Out Zones

Figure 29. Volumetric Keep-Out for FC-PGA and FC-PGA2<sup>1, 2</sup>

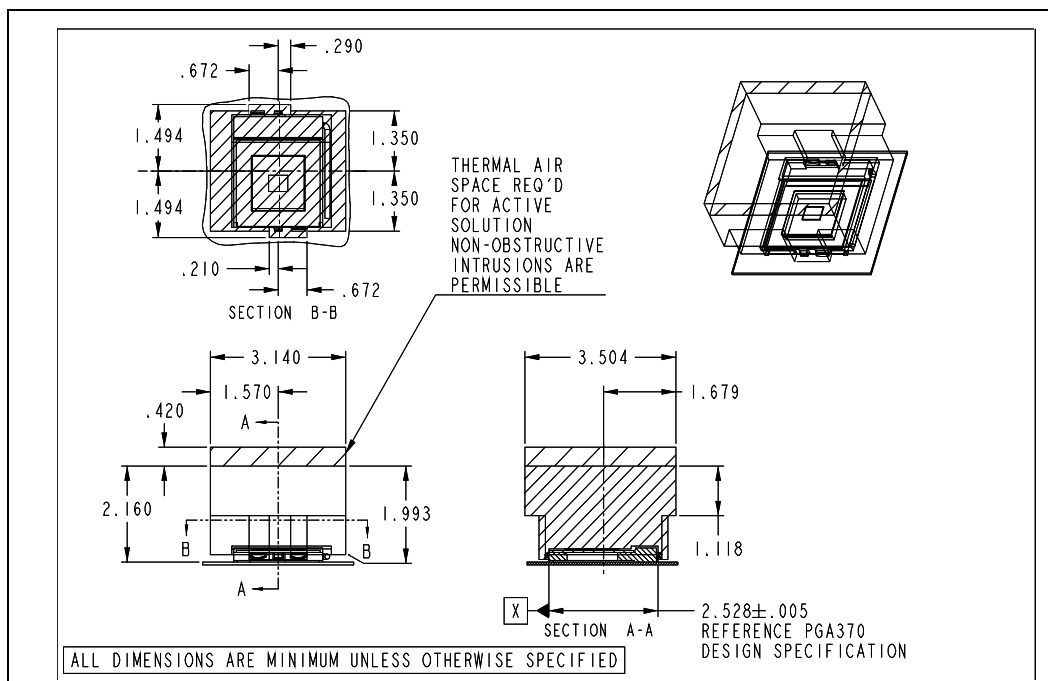

**NOTES:**

1. This drawing applies to FC-PGA2 package. The only differences from the FC-PGA package Keep-Out drawing are as follows: height 2.160" was changed from 2.100" and height 1.118" was changed from 1.058".
2. Refer to the Pentium III Thermal/Mechanical Solution Functional Guidelines (see section 1.2 for reference order number) for the latest information.

Figure 30. Component Keep-Out

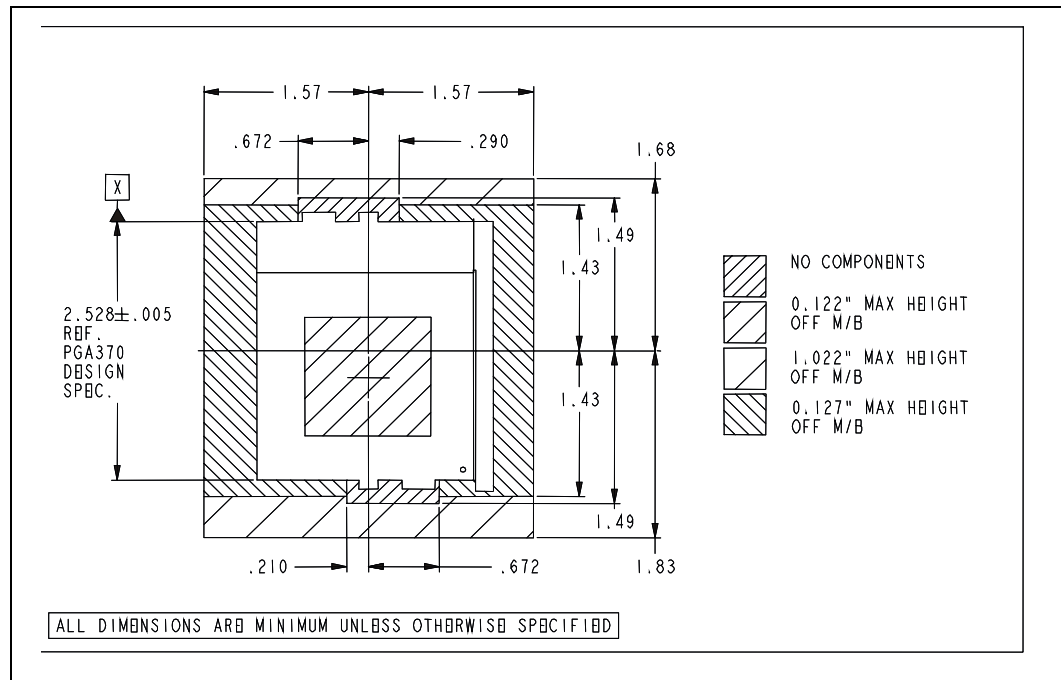

## 5.4 Processor Signal Listing

Table 39 and Table 40 provide the processor pin definitions. The signal locations on the PGA370 socket are to be used for signal routing, simulation, and component placement on the baseboard. Figure 31 provides a pin-side view of the Pentium III processor pinout.



Figure 31. Intel® Pentium® III Processor Pinout

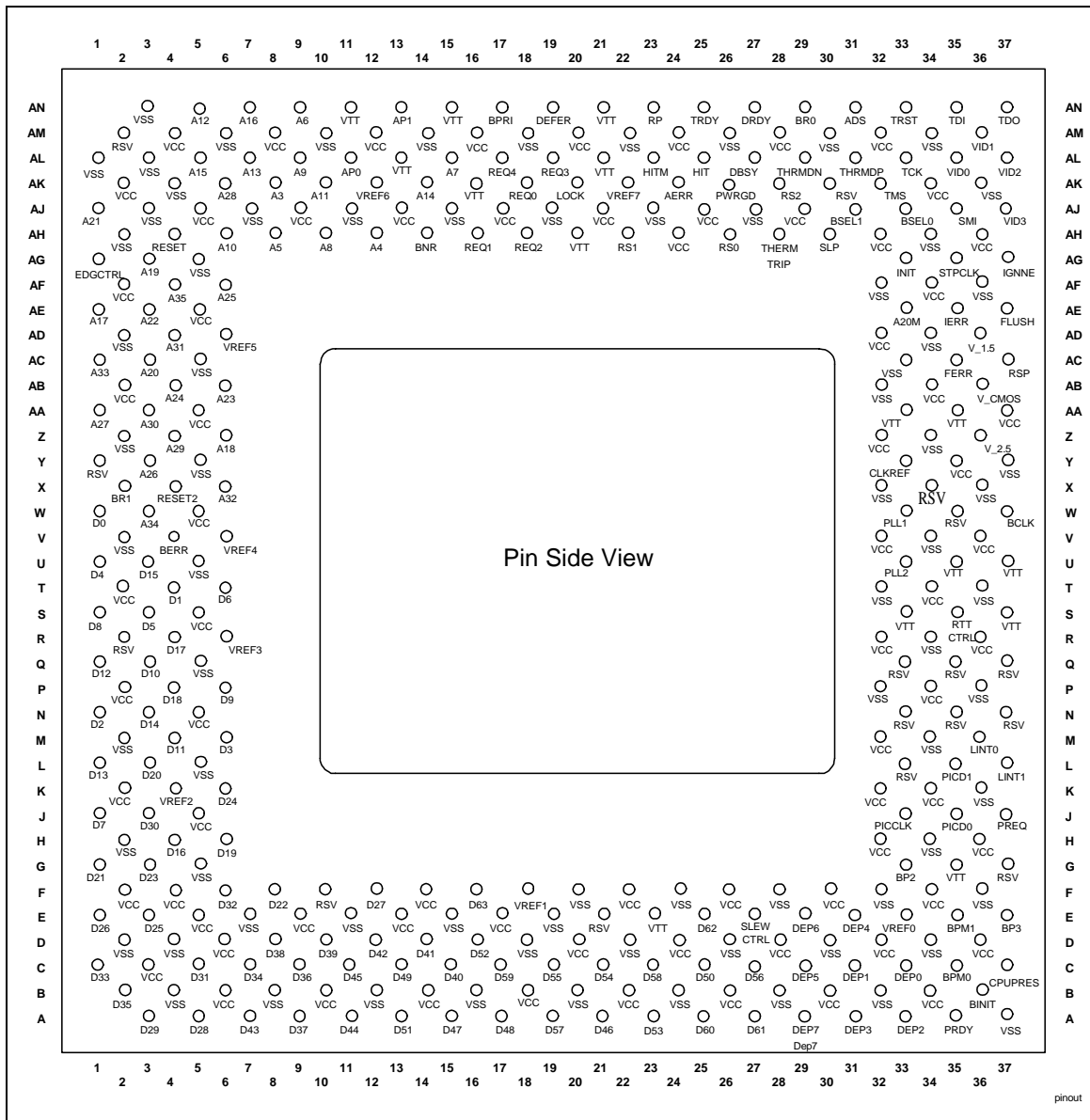

**Table 39. Signal Listing in Order by Signal Name**

Pin No.	Pin Name	Signal Group
AK8	A3#	AGTL+ I/O
AH12	A4#	AGTL+ I/O
AH8	A5#	AGTL+ I/O
AN9	A6#	AGTL+ I/O
AL15	A7#	AGTL+ I/O
AH10	A8#	AGTL+ I/O
AL9	A9#	AGTL+ I/O
AH6	A10#	AGTL+ I/O
AK10	A11#	AGTL+ I/O
AN5	A12#	AGTL+ I/O
AL7	A13#	AGTL+ I/O
AK14	A14#	AGTL+ I/O
AL5	A15#	AGTL+ I/O
AN7	A16#	AGTL+ I/O
AE1	A17#	AGTL+ I/O
Z6	A18#	AGTL+ I/O
AG3	A19#	AGTL+ I/O
AC3	A20#	AGTL+ I/O
AE33	A20M#	CMOS Input
AJ1	A21#	AGTL+ I/O
AE3	A22#	AGTL+ I/O
AB6	A23#	AGTL+ I/O
AB4	A24#	AGTL+ I/O
AF6	A25#	AGTL+ I/O
Y3	A26#	AGTL+ I/O
AA1	A27#	AGTL+ I/O
AK6	A28#	AGTL+ I/O
Z4	A29#	AGTL+ I/O
AA3	A30#	AGTL+ I/O
AD4	A31#	AGTL+ I/O
X6	A32#	AGTL+ I/O
AC1	A33#	AGTL+ I/O
W3	A34#	AGTL+ I/O
AF4	A35#	AGTL+ I/O
AN31	ADS#	AGTL+ I/O
AK24	AERR#	AGTL+ I/O
AL11	AP0#	AGTL+ I/O
AN13	AP1#	AGTL+ I/O
W37	BCLK	System Bus Clock
V4	BERR#	AGTL+ I/O

**Table 39. Signal Listing in Order by Signal Name (Continued)**

Pin No.	Pin Name	Signal Group
B36	BINIT#	AGTL+ I/O
AH14	BNR#	AGTL+ I/O
G33	BP2#	AGTL+ I/O
E37	BP3#	AGTL+ I/O
C35	BPM0#	AGTL+ I/O
E35	BPM1#	AGTL+ I/O
AN17	BPRI#	AGTL+ Input
AN29	BR0#	AGTL+ I/O
X2	BR1# <sup>8</sup>	AGTL+ Input
AJ33	BSEL0	Power/Other
AJ31	BSEL1	Power/Other
Y33	CLKREF <sup>7</sup>	Power/Other
C37	CPUPRES#	Power/Other
W1	D0#	AGTL+ I/O
T4	D1#	AGTL+ I/O
N1	D2#	AGTL+ I/O
M6	D3#	AGTL+ I/O
U1	D4#	AGTL+ I/O
S3	D5#	AGTL+ I/O
T6	D6#	AGTL+ I/O
J1	D7#	AGTL+ I/O
S1	D8#	AGTL+ I/O
P6	D9#	AGTL+ I/O
Q3	D10#	AGTL+ I/O
M4	D11#	AGTL+ I/O
Q1	D12#	AGTL+ I/O
L1	D13#	AGTL+ I/O
N3	D14#	AGTL+ I/O
U3	D15#	AGTL+ I/O
H4	D16#	AGTL+ I/O
R4	D17#	AGTL+ I/O
P4	D18#	AGTL+ I/O
H6	D19#	AGTL+ I/O
L3	D20#	AGTL+ I/O
G1	D21#	AGTL+ I/O
F8	D22#	AGTL+ I/O
G3	D23#	AGTL+ I/O
K6	D24#	AGTL+ I/O
E3	D25#	AGTL+ I/O
E1	D26#	AGTL+ I/O

**Table 39. Signal Listing in Order by Signal Name (Continued)**

Pin No.	Pin Name	Signal Group
F12	D27#	AGTL+ I/O
A5	D28#	AGTL+ I/O
A3	D29#	AGTL+ I/O
J3	D30#	AGTL+ I/O
C5	D31#	AGTL+ I/O
F6	D32#	AGTL+ I/O
C1	D33#	AGTL+ I/O
C7	D34#	AGTL+ I/O
B2	D35#	AGTL+ I/O
C9	D36#	AGTL+ I/O
A9	D37#	AGTL+ I/O
D8	D38#	AGTL+ I/O
D10	D39#	AGTL+ I/O
C15	D40#	AGTL+ I/O
D14	D41#	AGTL+ I/O
D12	D42#	AGTL+ I/O
A7	D43#	AGTL+ I/O
A11	D44#	AGTL+ I/O
C11	D45#	AGTL+ I/O
A21	D46#	AGTL+ I/O
A15	D47#	AGTL+ I/O
A17	D48#	AGTL+ I/O
C13	D49#	AGTL+ I/O
C25	D50#	AGTL+ I/O
A13	D51#	AGTL+ I/O
D16	D52#	AGTL+ I/O
A23	D53#	AGTL+ I/O
C21	D54#	AGTL+ I/O
C19	D55#	AGTL+ I/O
C27	D56#	AGTL+ I/O
A19	D57#	AGTL+ I/O
C23	D58#	AGTL+ I/O
C17	D59#	AGTL+ I/O
A25	D60#	AGTL+ I/O
A27	D61#	AGTL+ I/O
E25	D62#	AGTL+ I/O
F16	D63#	AGTL+ I/O
AL27	DBSY#	AGTL+ I/O
AN19	DEFER#	AGTL+ Input
C33	DEP0#	AGTL+ I/O

**Table 39. Signal Listing in Order by Signal Name (Continued)**

Pin No.	Pin Name	Signal Group
C31	DEP1#	AGTL+ I/O
A33	DEP2#	AGTL+ I/O
A31	DEP3#	AGTL+ I/O
E31	DEP4#	AGTL+ I/O
C29	DEP5#	AGTL+ I/O
E29	DEP6#	AGTL+ I/O
A29	DEP7#	AGTL+ I/O
AN27	DRDY#	AGTL+ I/O
AG1	EDGCTRL <sup>5</sup>	Power/Other
AC35	FERR#	CMOS Output
AE37	FLUSH#	CMOS Input
AM22	GND	Power/Other
AM26	GND	Power/Other
AM30	GND	Power/Other
AM34	GND	Power/Other
AM6	GND	Power/Other
AN3	GND	Power/Other
B12	GND	Power/Other
B16	GND	Power/Other
B20	GND	Power/Other
B24	GND	Power/Other
B28	GND	Power/Other
B32	GND	Power/Other
B4	GND	Power/Other
B8	GND	Power/Other
D18	GND	Power/Other
D2	GND	Power/Other
D22	GND	Power/Other
D26	GND	Power/Other
D30	GND	Power/Other
D34	GND	Power/Other
D4	GND	Power/Other
E11	GND	Power/Other
E15	GND	Power/Other
E19	GND	Power/Other
E7	GND	Power/Other
F20	GND	Power/Other
F24	GND	Power/Other
F28	GND	Power/Other
F32	GND	Power/Other

**Table 39. Signal Listing in Order by Signal Name (Continued)**

Pin No.	Pin Name	Signal Group
F36	GND	Power/Other
G5	GND	Power/Other
H2	GND	Power/Other
H34	GND	Power/Other
K36	GND	Power/Other
L5	GND	Power/Other
M2	GND	Power/Other
M34	GND	Power/Other
P32	GND	Power/Other
P36	GND	Power/Other
A37	GND	Power/Other
AB32	GND	Power/Other
AC33	GND	Power/Other
AC5	GND	Power/Other
AD2	GND	Power/Other
AD34	GND	Power/Other
AF32	GND	Power/Other
AF36	GND	Power/Other
AG5	GND	Power/Other
AH2	GND	Power/Other
AH34	GND	Power/Other
AJ11	GND	Power/Other
AJ15	GND	Power/Other
AJ19	GND	Power/Other
AJ23	GND	Power/Other
AJ27	GND	Power/Other
AJ3	GND	Power/Other
AJ7	GND	Power/Other
AK36	GND	Power/Other
AK4	GND	Power/Other
AL1	GND	Power/Other
AL3	GND	Power/Other
AM10	GND	Power/Other
AM14	GND	Power/Other
AM18	GND	Power/Other
Q5	GND	Power/Other
R34	GND	Power/Other
T32	GND	Power/Other
T36	GND	Power/Other
U5	GND	Power/Other

**Table 39. Signal Listing in Order by Signal Name (Continued)**

Pin No.	Pin Name	Signal Group
V2	GND	Power/Other
V34	GND	Power/Other
X32	GND	Power/Other
X36	GND	Power/Other
Y37	GND	Power/Other
Y5	GND	Power/Other
Z2	GND	Power/Other
Z34	GND	Power/Other
AL25	HIT#	AGTL+ I/O
AL23	HITM#	AGTL+ I/O
AE35	IERR#	CMOS Output
AG37	IGNNE#	CMOS Input
AG33	INIT#	CMOS Input
M36	LINT0/INTR	CMOS Input
L37	LINT1/NMI	CMOS Input
AK20	LOCK#	AGTL+ I/O
J33	PICCLK	APIC Clock Input
J35	PICD0	APIC I/O
L35	PICD1	APIC I/O
W33	PLL1	Power/Other
U33	PLL2	Power/Other
A35	PRDY#	AGTL+ Output
J37	PREQ#	CMOS Input
AK26	PWRGOOD	CMOS Input
AK18	REQ0#	AGTL+ I/O
AH16	REQ1#	AGTL+ I/O
AH18	REQ2#	AGTL+ I/O
AL19	REQ3#	AGTL+ I/O
AL17	REQ4#	AGTL+ I/O
G37	Reserved	Reserved for future use
L33	Reserved	Reserved for future use
N33	Reserved	Reserved for future use
N35	Reserved	Reserved for future use
N37	Reserved	Reserved for future use
Q33	Reserved	Reserved for future use
Q35	Reserved	Reserved for future use
Q37	Reserved	Reserved for future use
R2	Reserved	Reserved for future use
W35	Reserved	Reserved for future use
Y1	Reserved	Reserved for future use

**Table 39. Signal Listing in Order by Signal Name (Continued)**

Pin No.	Pin Name	Signal Group
AK30	Reserved	Reserved for future use
AM2 <sup>6</sup>	Reserved	Reserved for future use
F10	Reserved	Reserved for future use
X34	Reserved	Reserved for future use
E21	Reserved <sup>11</sup>	Reserved for future use
X2	BR1# <sup>8</sup>	AGTL+ Input
AH4	RESET# <sup>2</sup>	AGTL+ Input
X4	RESET2# <sup>2</sup>	AGTL+ I/O
AN23	RP#	AGTL+ I/O
AH26	RS0#	AGTL + Input
AH22	RS1#	AGTL+ Input
AK28	RS2#	AGTL+ Input
AC37	RSP#	AGTL+ Input
S35	RTTCTRL	Power/Other
E27	SLEWCTRL	Power/Other
AH30	SLP#	CMOS Input
AJ35	SMI#	CMOS Input
AG35	STPCLK#	CMOS Input
AL33	TCK	TAP Input
AN35	TDI	TAP Input
AN37	TDO	TAP Output
AL29	THERMDN	Power/Other
AL31	THERMDP	Power/Other
AH28	THERMTRIP#	CMOS Output
AK32	TMS	TAP Input
AN25	TRDY#	AGTL+ Input
AN33	TRST#	TAP Input
AD36	VCC <sub>1.5</sub> <sup>3</sup>	Power/Other
Z36	VCC <sub>2.5</sub> <sup>1</sup>	Power/Other
AB36	VCC <sub>CMOS</sub>	Power/Other
AA37	VCC <sub>CORE</sub>	Power/Other
AA5	VCC <sub>CORE</sub>	Power/Other
AB2	VCC <sub>CORE</sub>	Power/Other
AB34	VCC <sub>CORE</sub>	Power/Other
AD32	VCC <sub>CORE</sub>	Power/Other
AE5	VCC <sub>CORE</sub>	Power/Other
E5	VCC <sub>CORE</sub>	Power/Other
E9	VCC <sub>CORE</sub>	Power/Other
F14	VCC <sub>CORE</sub>	Power/Other
F2	VCC <sub>CORE</sub>	Power/Other

**Table 39. Signal Listing in Order by Signal Name (Continued)**

Pin No.	Pin Name	Signal Group
F22	VCC <sub>CORE</sub>	Power/Other
F26	VCC <sub>CORE</sub>	Power/Other
F30	VCC <sub>CORE</sub>	Power/Other
F34	VCC <sub>CORE</sub>	Power/Other
F4	VCC <sub>CORE</sub>	Power/Other
H32	VCC <sub>CORE</sub>	Power/Other
H36	VCC <sub>CORE</sub>	Power/Other
J5	VCC <sub>CORE</sub>	Power/Other
K2	VCC <sub>CORE</sub>	Power/Other
K32	VCC <sub>CORE</sub>	Power/Other
K34	VCC <sub>CORE</sub>	Power/Other
M32	VCC <sub>CORE</sub>	Power/Other
N5	VCC <sub>CORE</sub>	Power/Other
P2	VCC <sub>CORE</sub>	Power/Other
P34	VCC <sub>CORE</sub>	Power/Other
R32	VCC <sub>CORE</sub>	Power/Other
R36	VCC <sub>CORE</sub>	Power/Other
S5	VCC <sub>CORE</sub>	Power/Other
T2	VCC <sub>CORE</sub>	Power/Other
T34	VCC <sub>CORE</sub>	Power/Other
V32	VCC <sub>CORE</sub>	Power/Other
V36	VCC <sub>CORE</sub>	Power/Other
W5	VCC <sub>CORE</sub>	Power/Other
Y35	VCC <sub>CORE</sub>	Power/Other
Z32	VCC <sub>CORE</sub>	Power/Other
AF2	VCC <sub>CORE</sub>	Power/Other
AF34	VCC <sub>CORE</sub>	Power/Other
AH24	VCC <sub>CORE</sub>	Power/Other
AH32	VCC <sub>CORE</sub>	Power/Other
AH36	VCC <sub>CORE</sub>	Power/Other
AJ13	VCC <sub>CORE</sub>	Power/Other
AJ17	VCC <sub>CORE</sub>	Power/Other
AJ21	VCC <sub>CORE</sub>	Power/Other
AJ25	VCC <sub>CORE</sub>	Power/Other
AJ29	VCC <sub>CORE</sub>	Power/Other
AJ5	VCC <sub>CORE</sub>	Power/Other
AK2	VCC <sub>CORE</sub>	Power/Other
AK34	VCC <sub>CORE</sub>	Power/Other
AM12	VCC <sub>CORE</sub>	Power/Other
AM16	VCC <sub>CORE</sub>	Power/Other



**Table 39. Signal Listing in Order by Signal Name (Continued)**

Pin No.	Pin Name	Signal Group
AM20	VCC <sub>CORE</sub>	Power/Other
AM24	VCC <sub>CORE</sub>	Power/Other
AM28	VCC <sub>CORE</sub>	Power/Other
AM32	VCC <sub>CORE</sub>	Power/Other
AM4	VCC <sub>CORE</sub>	Power/Other
AM8	VCC <sub>CORE</sub>	Power/Other
B10	VCC <sub>CORE</sub>	Power/Other
B14	VCC <sub>CORE</sub>	Power/Other
B18	VCC <sub>CORE</sub>	Power/Other
B22	VCC <sub>CORE</sub>	Power/Other
B26	VCC <sub>CORE</sub>	Power/Other
B30	VCC <sub>CORE</sub>	Power/Other
B34	VCC <sub>CORE</sub>	Power/Other
B6	VCC <sub>CORE</sub>	Power/Other
C3	VCC <sub>CORE</sub>	Power/Other
D20	VCC <sub>CORE</sub>	Power/Other
D24	VCC <sub>CORE</sub>	Power/Other
D28	VCC <sub>CORE</sub>	Power/Other
D32	VCC <sub>CORE</sub>	Power/Other
D36	VCC <sub>CORE</sub>	Power/Other
D6	VCC <sub>CORE</sub>	Power/Other
E13	VCC <sub>CORE</sub>	Power/Other
E17	VCC <sub>CORE</sub>	Power/Other
AJ9	VCC <sub>CORE</sub>	Power/Other
AL35	VID0	Power/Other
AM36	VID1	Power/Other

**Table 39. Signal Listing in Order by Signal Name (Continued)**

Pin No.	Pin Name	Signal Group
AL37	VID2	Power/Other
AJ37	VID3	Power/Other
E33	V <sub>REF</sub> 0	Power/Other
F18	V <sub>REF</sub> 1	Power/Other
K4	V <sub>REF</sub> 2	Power/Other
R6	V <sub>REF</sub> 3	Power/Other
V6	V <sub>REF</sub> 4	Power/Other
AD6	V <sub>REF</sub> 5	Power/Other
AK12	V <sub>REF</sub> 6	Power/Other
AK22	V <sub>REF</sub> 7	Power/Other
AH20	V <sub>TT</sub>	Power/Other
AK16	V <sub>TT</sub>	Power/Other
AL13	V <sub>TT</sub>	Power/Other
AL21	V <sub>TT</sub>	Power/Other
AN11	V <sub>TT</sub>	Power/Other
AN15	V <sub>TT</sub>	Power/Other
G35	V <sub>TT</sub>	Power/Other
AA33	V <sub>TT</sub> <sup>4</sup>	Power/Other
AA35	V <sub>TT</sub> <sup>4</sup>	Power/Other
AN21	V <sub>TT</sub> <sup>4</sup>	Power/Other
E23	V <sub>TT</sub> <sup>4</sup>	Power/Other
S33	V <sub>TT</sub> <sup>4</sup>	Power/Other
S37	V <sub>TT</sub> <sup>4</sup>	Power/Other
U35	V <sub>TT</sub> <sup>4</sup>	Power/Other
U37	V <sub>TT</sub> <sup>4</sup>	Power/Other

**Table 40. Signal Listing in Order by Pin Number**

Pin No.	Pin Name	Signal Group
A3	D29#	AGTL+ I/O
A5	D28#	AGTL+ I/O
A7	D43#	AGTL+ I/O
A9	D37#	AGTL+ I/O
A11	D44#	AGTL+ I/O
A13	D51#	AGTL+ I/O
A15	D47#	AGTL+ I/O
A17	D48#	AGTL+ I/O
A19	D57#	AGTL+ I/O
A21	D46#	AGTL+ I/O
A23	D53#	AGTL+ I/O
A25	D60#	AGTL+ I/O
A27	D61#	AGTL+ I/O
A29	DEP7#	AGTL+ I/O
A31	DEP3#	AGTL+ I/O
A33	DEP2#	AGTL+ I/O
A35	PRDY#	AGTL+ Output
A37	GND	Power/Other
AA1	A27#	AGTL+ I/O
AA3	A30#	AGTL+ I/O
AA5	VCC <sub>CORE</sub>	Power/Other
AA33	VTT <sup>4</sup>	Power/Other
AA35	VTT <sup>4</sup>	Power/Other
AA37	VCC <sub>CORE</sub>	Power/Other
AB2	VCC <sub>CORE</sub>	Power/Other
AB4	A24#	AGTL+ I/O
AB6	A23#	AGTL+ I/O
AB32	GND	Power/Other
AB34	VCC <sub>CORE</sub>	Power/Other
AB36	VCC <sub>CMOS</sub>	Power/Other
AC1	A33#	AGTL+ I/O
AC3	A20#	AGTL+ I/O
AC5	GND	Power/Other
AC33	GND	Power/Other
AC35	FERR#	CMOS Output
AC37	RSP#	AGTL+ Input
AD2	GND	Power/Other
AD4	A31#	AGTL+ I/O
AD6	V <sub>REF5</sub>	Power/Other
AD32	VCC <sub>CORE</sub>	Power/Other

**Table 40. Signal Listing in Order by Pin Number (Continued)**

Pin No.	Pin Name	Signal Group
AD34	GND	Power/Other
AD36	VCC <sub>1.5</sub> <sup>3</sup>	Power/Other
AE1	A17#	AGTL+ I/O
AE3	A22#	AGTL+ I/O
AE5	VCC <sub>CORE</sub>	Power/Other
AE33	A20M#	CMOS Input
AE35	IERR#	CMOS Output
AE37	FLUSH#	CMOS Input
AF2	VCC <sub>CORE</sub>	Power/Other
AF4	A35#	AGTL+ I/O
AF6	A25#	AGTL+ I/O
AF32	GND	Power/Other
AF34	VCC <sub>CORE</sub>	Power/Other
AF36	GND	Power/Other
AG1	EDGCTRL <sup>5</sup>	Power/Other
AG3	A19#	AGTL+ I/O
AG5	GND	Power/Other
AG33	INIT#	CMOS Input
AG35	STPCLK#	CMOS Input
AG37	IGNNE#	CMOS Input
AH2	GND	Power/Other
AH4	RESET# <sup>2</sup>	AGTL+ Input
AH6	A10#	AGTL+ I/O
AH8	A5#	AGTL+ I/O
AH10	A8#	AGTL+ I/O
AH12	A4#	AGTL+ I/O
AH14	BNR#	AGTL+ I/O
AH16	REQ1#	AGTL+ I/O
AH18	REQ2#	AGTL+ I/O
AH20	VTT	Power/Other
AH22	RS1#	AGTL+ Input
AH24	VCC <sub>CORE</sub>	Power/Other
AH26	RS0#	AGTL + Input
AH28	THERMTRIP#	CMOS Output
AH30	SLP#	CMOS Input
AH32	VCC <sub>CORE</sub>	Power/Other
AH34	GND	Power/Other
AH36	VCC <sub>CORE</sub>	Power/Other
AJ1	A21#	AGTL+ I/O
AJ3	GND	Power/Other

**Table 40. Signal Listing in Order by Pin Number (Continued)**

Pin No.	Pin Name	Signal Group
AJ5	VCC <sub>CORE</sub>	Power/Other
AJ7	GND	Power/Other
AJ9	VCC <sub>CORE</sub>	Power/Other
AJ11	GND	Power/Other
AJ13	VCC <sub>CORE</sub>	Power/Other
AJ15	GND	Power/Other
AJ17	VCC <sub>CORE</sub>	Power/Other
AJ19	GND	Power/Other
AJ21	VCC <sub>CORE</sub>	Power/Other
AJ23	GND	Power/Other
AJ25	VCC <sub>CORE</sub>	Power/Other
AJ27	GND	Power/Other
AJ29	VCC <sub>CORE</sub>	Power/Other
AJ31	BSEL1	Power/Other
AJ33	BSEL0	Power/Other
AJ35	SMI#	CMOS Input
AJ37	VID3	Power/Other
AK2	VCC <sub>CORE</sub>	Power/Other
AK4	GND	Power/Other
AK6	A28#	AGTL+ I/O
AK8	A3#	AGTL+ I/O
AK10	A11#	AGTL+ I/O
AK12	V <sub>REF6</sub>	Power/Other
AK14	A14#	AGTL+ I/O
AK16	VTT	Power/Other
AK18	REQ0#	AGTL+ I/O
AK20	LOCK#	AGTL+ I/O
AK22	V <sub>REF7</sub>	Power/Other
AK24	AERR#	AGTL+ I/O
AK26	PWRGOOD	CMOS Input
AK28	RS2#	AGTL+ Input
AK30	Reserved	Reserved for future use
AK32	TMS	TAP Input
AK34	VCC <sub>CORE</sub>	Power/Other
AK36	GND	Power/Other
AL1	GND	Power/Other
AL3	GND	Power/Other
AL5	A15#	AGTL+ I/O
AL7	A13#	AGTL+ I/O
AL9	A9#	AGTL+ I/O

**Table 40. Signal Listing in Order by Pin Number (Continued)**

Pin No.	Pin Name	Signal Group
AL11	AP0#	AGTL+ I/O
AL13	VTT	Power/Other
AL15	A7#	AGTL+ I/O
AL17	REQ4#	AGTL+ I/O
AL19	REQ3#	AGTL+ I/O
AL21	VTT	Power/Other
AL23	HITM#	AGTL+ I/O
AL25	HIT#	AGTL+ I/O
AL27	DBSY#	AGTL+ I/O
AL29	THERMDN	Power/Other
AL31	THERMDP	Power/Other
AL33	TCK	TAP Input
AL35	VID0	Power/Other
AL37	VID2	Power/Other
AM2 <sup>6</sup>	Reserved	Reserved for future use
AM4	VCC <sub>CORE</sub>	Power/Other
AM6	GND	Power/Other
AM8	VCC <sub>CORE</sub>	Power/Other
AM10	GND	Power/Other
AM12	VCC <sub>CORE</sub>	Power/Other
AM14	GND	Power/Other
AM16	VCC <sub>CORE</sub>	Power/Other
AM18	GND	Power/Other
AM20	VCC <sub>CORE</sub>	Power/Other
AM22	GND	Power/Other
AM24	VCC <sub>CORE</sub>	Power/Other
AM26	GND	Power/Other
AM28	VCC <sub>CORE</sub>	Power/Other
AM30	GND	Power/Other
AM32	VCC <sub>CORE</sub>	Power/Other
AM34	GND	Power/Other
AM36	VID1	Power/Other
AN3	GND	Power/Other
AN5	A12#	AGTL+ I/O
AN7	A16#	AGTL+ I/O
AN9	A6#	AGTL+ I/O
AN11	VTT	Power/Other
AN13	AP1#	AGTL+ I/O
AN15	VTT	Power/Other
AN17	BPRI#	AGTL+ Input

**Table 40. Signal Listing in Order by Pin Number (Continued)**

Pin No.	Pin Name	Signal Group
AN19	DEFER#	AGTL+ Input
AN21	VTT <sup>4</sup>	Power/Other
AN23	RP#	AGTL+ I/O
AN25	TRDY#	AGTL+ Input
AN27	DRDY#	AGTL+ I/O
AN29	BR0#	AGTL+ I/O
AN31	ADS#	AGTL+ I/O
AN33	TRST#	TAP Input
AN35	TDI	TAP Input
AN37	TDO	TAP Output
B2	D35#	AGTL+ I/O
B4	GND	Power/Other
B6	VCC <sub>CORE</sub>	Power/Other
B8	GND	Power/Other
B10	VCC <sub>CORE</sub>	Power/Other
B12	GND	Power/Other
B14	VCC <sub>CORE</sub>	Power/Other
B16	GND	Power/Other
B18	VCC <sub>CORE</sub>	Power/Other
B20	GND	Power/Other
B22	VCC <sub>CORE</sub>	Power/Other
B24	GND	Power/Other
B26	VCC <sub>CORE</sub>	Power/Other
B28	GND	Power/Other
B30	VCC <sub>CORE</sub>	Power/Other
B32	GND	Power/Other
B34	VCC <sub>CORE</sub>	Power/Other
B36	BINIT#	AGTL+ I/O
C1	D33#	AGTL+ I/O
C3	VCC <sub>CORE</sub>	Power/Other
C5	D31#	AGTL+ I/O
C7	D34#	AGTL+ I/O
C9	D36#	AGTL+ I/O
C11	D45#	AGTL+ I/O
C13	D49#	AGTL+ I/O
C15	D40#	AGTL+ I/O
C17	D59#	AGTL+ I/O
C19	D55#	AGTL+ I/O
C21	D54#	AGTL+ I/O
C23	D58#	AGTL+ I/O

**Table 40. Signal Listing in Order by Pin Number (Continued)**

Pin No.	Pin Name	Signal Group
C25	D50#	AGTL+ I/O
C27	D56#	AGTL+ I/O
C29	DEP5#	AGTL+ I/O
C31	DEP1#	AGTL+ I/O
C33	DEP0#	AGTL+ I/O
C35	BPM0#	AGTL+ I/O
C37	CPUPRES#	Power/Other
D2	GND	Power/Other
D4	GND	Power/Other
D6	VCC <sub>CORE</sub>	Power/Other
D8	D38#	AGTL+ I/O
D10	D39#	AGTL+ I/O
D12	D42#	AGTL+ I/O
D14	D41#	AGTL+ I/O
D16	D52#	AGTL+ I/O
D18	GND	Power/Other
D20	VCC <sub>CORE</sub>	Power/Other
D22	GND	Power/Other
D24	VCC <sub>CORE</sub>	Power/Other
D26	GND	Power/Other
D28	VCC <sub>CORE</sub>	Power/Other
D30	GND	Power/Other
D32	VCC <sub>CORE</sub>	Power/Other
D34	GND	Power/Other
D36	VCC <sub>CORE</sub>	Power/Other
E1	D26#	AGTL+ I/O
E3	D25#	AGTL+ I/O
E5	VCC <sub>CORE</sub>	Power/Other
E7	GND	Power/Other
E9	VCC <sub>CORE</sub>	Power/Other
E11	GND	Power/Other
E13	VCC <sub>CORE</sub>	Power/Other
E15	GND	Power/Other
E17	VCC <sub>CORE</sub>	Power/Other
E19	GND	Power/Other
E21	Reserved <sup>11</sup>	Reserved for future use
E23	VTT <sup>4</sup>	Power/Other
E25	D62#	AGTL+ I/O
E27	SLEWCTRL	Power/Other
E29	DEP6#	AGTL+ I/O

**Table 40. Signal Listing in Order by Pin Number (Continued)**

Pin No.	Pin Name	Signal Group
E31	DEP4#	AGTL+ I/O
E33	V <sub>REF0</sub>	Power/Other
E35	BPM1#	AGTL+ I/O
E37	BP3#	AGTL+ I/O
F2	V <sub>CC</sub> CORE	Power/Other
F4	V <sub>CC</sub> CORE	Power/Other
F6	D32#	AGTL+ I/O
F8	D22#	AGTL+ I/O
F10	Reserved	Reserved for future use
F12	D27#	AGTL+ I/O
F14	V <sub>CC</sub> CORE	Power/Other
F16	D63#	AGTL+ I/O
F18	V <sub>REF1</sub>	Power/Other
F20	GND	Power/Other
F22	V <sub>CC</sub> CORE	Power/Other
F24	GND	Power/Other
F26	V <sub>CC</sub> CORE	Power/Other
F28	GND	Power/Other
F30	V <sub>CC</sub> CORE	Power/Other
F32	GND	Power/Other
F34	V <sub>CC</sub> CORE	Power/Other
F36	GND	Power/Other
G1	D21#	AGTL+ I/O
G3	D23#	AGTL+ I/O
G5	GND	Power/Other
G33	BP2#	AGTL+ I/O
G35	V <sub>TT</sub>	Power/Other
G37	Reserved	Reserved for future use
H2	GND	Power/Other
H4	D16#	AGTL+ I/O
H6	D19#	AGTL+ I/O
H32	V <sub>CC</sub> CORE	Power/Other
H34	GND	Power/Other
H36	V <sub>CC</sub> CORE	Power/Other
J1	D7#	AGTL+ I/O
J3	D30#	AGTL+ I/O
J5	V <sub>CC</sub> CORE	Power/Other
J33	PICCLK	APIC Clock Input
J35	PICD0	APIC I/O
J37	PREQ#	CMOS Input

**Table 40. Signal Listing in Order by Pin Number (Continued)**

Pin No.	Pin Name	Signal Group
K2	V <sub>CC</sub> CORE	Power/Other
K4	V <sub>REF2</sub>	Power/Other
K6	D24#	AGTL+ I/O
K32	V <sub>CC</sub> CORE	Power/Other
K34	V <sub>CC</sub> CORE	Power/Other
K36	GND	Power/Other
L1	D13#	AGTL+ I/O
L3	D20#	AGTL+ I/O
L5	GND	Power/Other
L33	Reserved	Reserved for future use
L35	PICD1	APIC I/O
L37	LINT1/NMI	CMOS Input
M2	GND	Power/Other
M4	D11#	AGTL+ I/O
M6	D3#	AGTL+ I/O
M32	V <sub>CC</sub> CORE	Power/Other
M34	GND	Power/Other
M36	LINT0/INTR	CMOS Input
N1	D2#	AGTL+ I/O
N3	D14#	AGTL+ I/O
N5	V <sub>CC</sub> CORE	Power/Other
N33	Reserved	Reserved for future use
N35	Reserved	Reserved for future use
N37	Reserved	Reserved for future use
P2	V <sub>CC</sub> CORE	Power/Other
P4	D18#	AGTL+ I/O
P6	D9#	AGTL+ I/O
P32	GND	Power/Other
P34	V <sub>CC</sub> CORE	Power/Other
P36	GND	Power/Other
Q1	D12#	AGTL+ I/O
Q3	D10#	AGTL+ I/O
Q5	GND	Power/Other
Q33	Reserved	Reserved for future use
Q35	Reserved	Reserved for future use
Q37	Reserved	Reserved for future use
R2	Reserved	Reserved for future use
R4	D17#	AGTL+ I/O
R6	V <sub>REF3</sub>	Power/Other
R32	V <sub>CC</sub> CORE	Power/Other

**Table 40. Signal Listing in Order by Pin Number (Continued)**

Pin No.	Pin Name	Signal Group
R34	GND	Power/Other
R36	VCC <sub>CORE</sub>	Power/Other
S1	D8#	AGTL+ I/O
S3	D5#	AGTL+ I/O
S5	VCC <sub>CORE</sub>	Power/Other
S33	VTT <sup>4</sup>	Power/Other
S35	RTTCTRL	Power/Other
S37	VTT <sup>4</sup>	Power/Other
T2	VCC <sub>CORE</sub>	Power/Other
T4	D1#	AGTL+ I/O
T6	D6#	AGTL+ I/O
T32	GND	Power/Other
T34	VCC <sub>CORE</sub>	Power/Other
T36	GND	Power/Other
U1	D4#	AGTL+ I/O
U3	D15#	AGTL+ I/O
U5	GND	Power/Other
U33	PLL2	Power/Other
U35	VTT <sup>4</sup>	Power/Other
U37	VTT <sup>4</sup>	Power/Other
V2	GND	Power/Other
V4	BERR#	AGTL+ I/O
V6	VREF <sup>4</sup>	Power/Other
V32	VCC <sub>CORE</sub>	Power/Other
V34	GND	Power/Other

**Table 40. Signal Listing in Order by Pin Number (Continued)**

Pin No.	Pin Name	Signal Group
V36	VCC <sub>CORE</sub>	Power/Other
W1	D0#	AGTL+ I/O
W3	A34#	AGTL+ I/O
W5	VCC <sub>CORE</sub>	Power/Other
W33	PLL1	Power/Other
W35	Reserved	Reserved for future use
W37	BCLK	System Bus Clock
X2	BR1# <sup>8</sup>	AGTL+ input
X4	RESET2# <sup>2</sup>	AGTL+ I/O
X6	A32#	AGTL+ I/O
X32	GND	Power/Other
X34	Reserved	Reserved for future use
X36	GND	Power/Other
Y1	Reserved	Reserved for future use
Y3	A26#	AGTL+ I/O
Y5	GND	Power/Other
Y33	CLKREF <sup>7</sup>	Power/Other
Y35	VCC <sub>CORE</sub>	Power/Other
Y37	GND	Power/Other
Z2	GND	Power/Other
Z4	A29#	AGTL+ I/O
Z6	A18#	AGTL+ I/O
Z32	VCC <sub>CORE</sub>	Power/Other
Z34	GND	Power/Other
Z36	VCC <sub>2.5</sub> <sup>1</sup>	Power/Other

**NOTES:** See next page for notes.

**NOTES:**

1. These pins are required for backwards compatibility with other Intel processors. They are not used by the Pentium III processor. Refer to the appropriate platform design guide and [Section 7.1](#) for implementation details.
2. RESET# signal must be connected to pins AH4 and X4 for backwards compatibility. Refer to the appropriate platform design guide and [Section 7.1](#) for implementation details. If backwards compatibility is not required, then RESET2# (X4) should be connected to GND.
3. VCC<sub>1.5V</sub> must be supplied by the same voltage source supplying the VTT pins.
4. These VTT pins must be left unconnected (N/C) for backwards compatibility with Celeron processors (CPUID 066xh). For designs which do not support the Celeron processors (CPUID 066xh), and for compatibility with future processors, these VTT pins should be connected to the VTT plane. Refer to the appropriate platform design guide and [Section 7.1](#) for implementation details. For dual processor designs, these pins must be connected to VTT.
5. This pin is required for backwards compatibility. If backwards compatibility is not required, this pin may be left connected to VCC<sub>CORE</sub>. Refer to the appropriate platform design guide for implementation details.
6. Previously, PGA370 designs defined this pin as a GND. It is now reserved and must be left unconnected (N/C).
7. Previously, PGA370 socket designs defined this pin as a GND. It is now CLKREF.
8. For Uniprocessor designs, this pin is not used and it is defined as RESERVED. Refer to the *Pentium® III processor Specification Update* for a complete listing of processors that support DP operation.
9. Future low voltage AGTL PGA370 designs will redefine this pin as VTT. Refer to the appropriate platform design guide for connectivity and to the *Pentium® III processor Specification Update* for a complete listing of processors that support the new pinout definition.
10. Future low voltage AGTL PGA370 designs define these pins as GND. Refer to the appropriate platform design guide for connectivity and to the *Pentium® III processor Specification Update* for a complete listing of processors that support the new pinout definition.
11. Future low voltage AGTL PGA370 designs define this pin as RESERVED and must be left unconnected. Refer to the appropriate platform design guide for connectivity.
12. Future low voltage AGTL PGA370 designs will redefine these pins. Refer to the appropriate platform design guide for connectivity and to the *Pentium® III processor Specification Update* for a complete listing of processors that support the new pinout definition.
13. On AGTL and differential clock platforms, this pin is defined as BCLK#.

## 6.0 Boxed Processor Specifications

The Pentium III processor for the PGA370 socket is also offered as an Intel boxed processor. Intel boxed processors are intended for system integrators who build systems from motherboards and standard components. The boxed Pentium III processor for the PGA370 socket will be supplied with an unattached fan heatsink. This section documents motherboard and system requirements for the fan heatsink that will be supplied with the boxed Pentium III processor. This section is particularly important for OEMs that manufacture motherboards for system integrators. Unless otherwise noted, all figures in this section are dimensioned in inches.

**Note:** Drawings in this section reflect only the specifications on the Intel boxed processor product. These dimensions should not be used as a generic keep-out zone for all heatsinks. It is the system designer's responsibility to consider their proprietary solution when designing to the required keep-out zone on their system platform and chassis. Refer to the *Intel® Pentium® III Processor Thermal/Mechanical Functional Specifications* for further guidance. Contact your local Intel Sales Representative for this document.

**Figure 32. Conceptual Boxed Intel® Pentium® III Processor for the PGA370 Socket**

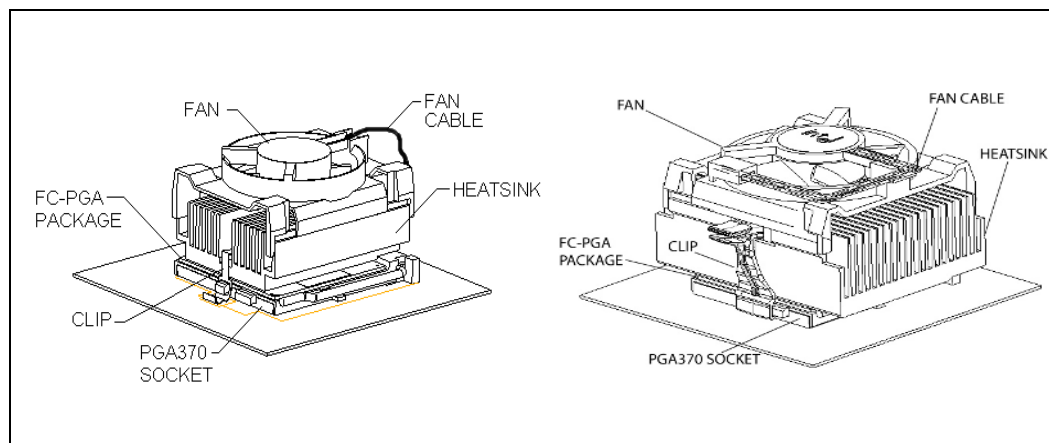

### 6.1 Mechanical Specifications for the Boxed Intel® Pentium® III Processor

#### 6.1.1 Boxed Processor Thermal Cooling Solution Dimensions

This section documents the mechanical specifications of the boxed Pentium III processor fan heatsink in the FC-PGA package. The boxed processor in the FC-PGA package ships with an unattached fan heatsink. Figure 32 shows a mechanical representation of the boxed Pentium III processor for the PGA370 socket in the Flip Chip Pin Grid Array (FC-PGA) package.

Section 5.3 of this document also shows the recommended mechanical keepout zones for the boxed processor fan heatsink assembly. Figure 30 and Figure 31 show the **required** keepout dimensions for the boxed processor thermal solution. The cooling fin orientation on the heatsink relative to the PGA-370 socket is subject to change. Contact your local Intel Sales Representative for documentation specific to the boxed fan heatsink orientation relative to the PGA-370 socket. Also, contact your Intel representative for specific fan heatsink dimensions.



The fan heatsink is designed to allow visibility of the FC-PGA processor markings located on top of the package. The FC-PGA processor markings are visible after installation of the fan heatsink due to notched sides of the heatsink base (see [Figure 34](#)). The boxed processor fan heatsink is also asymmetrical in that the mechanical step feature (see [Figure 33](#)) must sit over the socket's cam. The step allows the heatsink to securely interface with the processor in order to meet thermal requirements.

Note: The heatsink airflow keepout zones found in [Figure 35](#) refer specifically to the boxed processor's active fan heatsink. This does not reflect the worst-case dimensions that may exist with other third party passive or active fan heatsinks.

The Pentium III processor is manufactured in two different packages: FC-PGA and FC-PGA2. For specifications on these two packages please see [Section 5.0](#) of this document. Not all frequencies of Pentium III processors are offered in both packages. The thermal solutions for these two packages are incompatible. Therefore, the thermal solution shipped with each boxed Pentium III processor should only be used with the accompanied processor.

**Figure 33. Dimensions of Mechanical Step Feature in Heatsink Base**

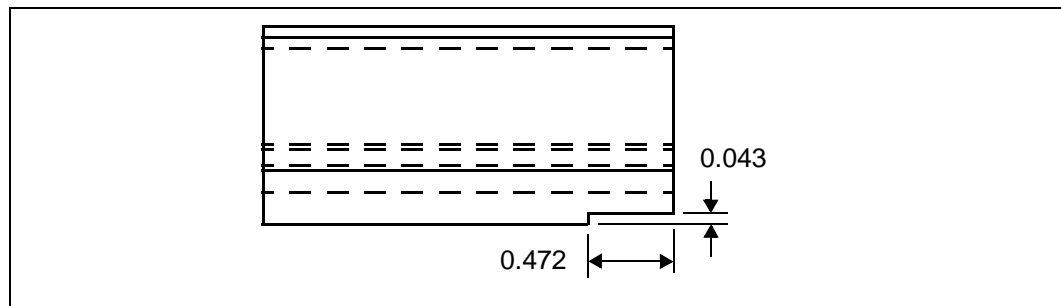

### 6.1.2 Boxed Processor Heatsink Weight

The boxed processor thermal cooling solution will not weigh more than 180 grams.

Figure 34. Dimensions of Notches in Heatsink Base

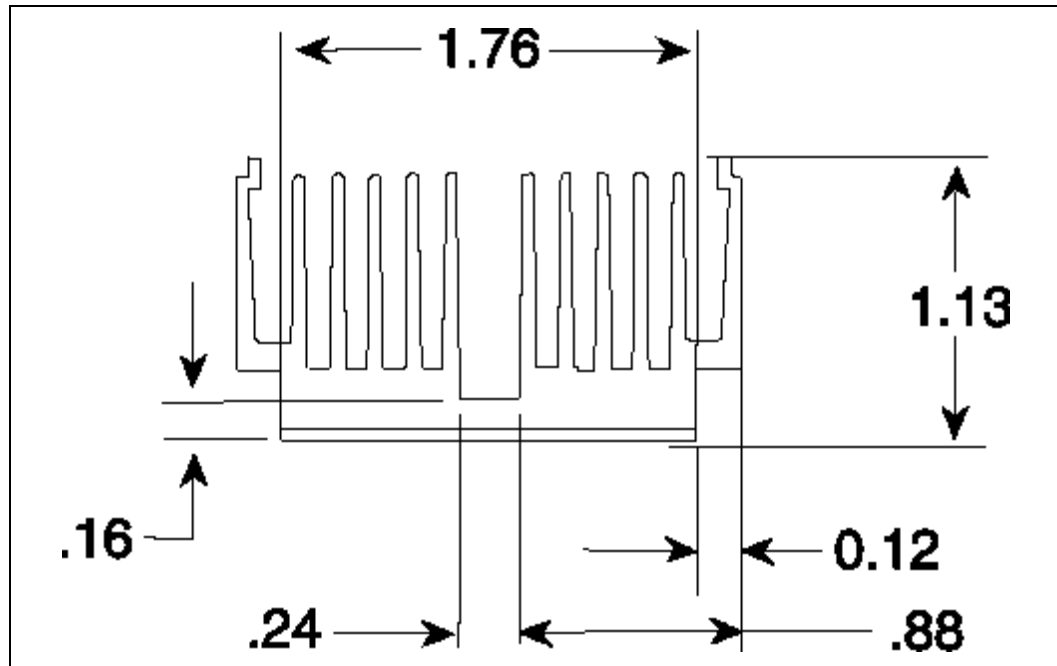

### 6.1.3 Boxed Processor Thermal Cooling Solution Clip

The boxed processor thermal solution requires installation by a system integrator to secure the thermal cooling solution to the processor after it is installed in the 370-pin socket ZIF socket. Motherboards designed for use by system integrators should take care to consider the implications of clip installation and potential scraping of the motherboard PCB underneath the 370-pin socket attach tabs. Motherboard components should not be placed too close to the 370-pin socket attach tabs in a way that interferes with the installation of the boxed processor thermal cooling solution (see [Section 5.3](#) for specification).

## 6.2 Thermal Specifications

This section describes the cooling requirements of the thermal cooling solution utilized by the boxed processor.

### 6.2.1 Boxed Processor Cooling Requirements

The boxed processor is directly cooled with a fan heatsink. However, meeting the processor's temperature specification is also a function of the thermal design of the entire system, and ultimately the responsibility of the system integrator. The processor temperature specification is found in [Section 4.0](#) of this document. The boxed processor fan heatsink is able to keep the processor core within the specifications (see [Table 33](#) and [Table 34](#)) in chassis that provide good thermal management.

For the boxed processor fan heatsink to operate properly, it is critical that the airflow provided to the fan heatsink is unimpeded. Airflow of the fan heatsink is into the center and out of the sides of the fan heatsink. Airspace is required around the fan to ensure that the airflow through the fan heatsink is not blocked. Blocking the airflow to the fan heatsink reduces the cooling efficiency and decreases fan life. Figure 35 illustrates an acceptable airspace clearance for the fan heatsink. It is also recommended that the air temperature entering the fan be kept below 45 °C. Meeting the processor's temperature specification is the responsibility of the system integrator. The processor temperature specification is found in Section 4.0 of this document.

**Figure 35. Thermal Airspace Requirement for all Boxed Intel® Pentium® III Processor Fan Heatsinks in the PGA370 Socket**

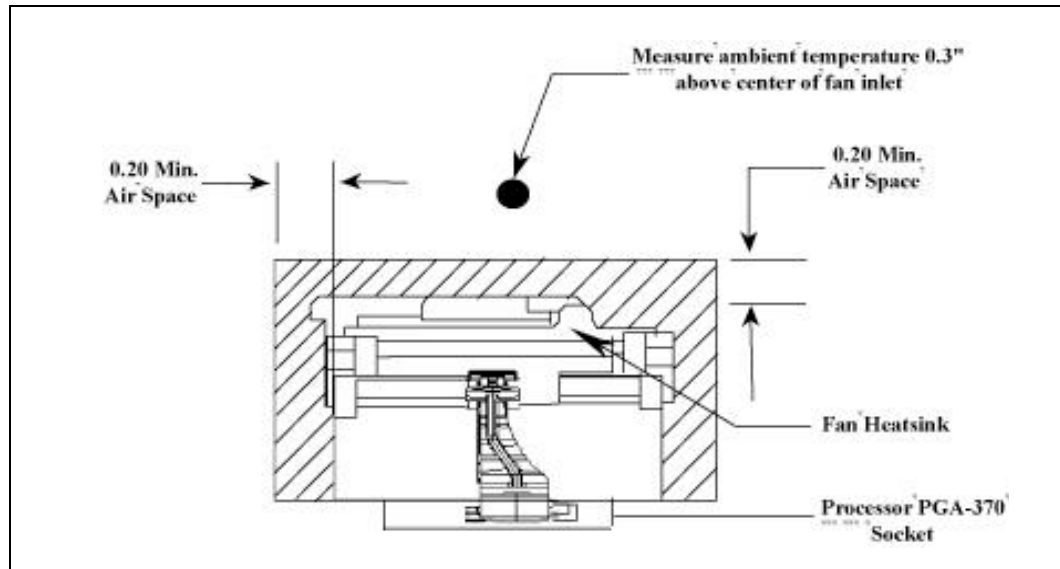

## 6.3 Electrical Requirements for the Boxed Intel® Pentium® III Processor

### 6.3.1 Fan Heatsink Power Supply

The boxed processor's fan heatsink requires a +12 V power supply. A fan power cable is attached to the fan and will draw power from a power header on the motherboard. The power cable connector and pinout are shown in Figure 36. Motherboards must provide a matched power header to support the boxed processor. Table 41 contains specifications for the input and output signals at the fan heatsink connector. The fan heatsink outputs a SENSE (open-collector output) signal that pulses at a rate of two pulses per fan revolution. A motherboard pull-up resistor provides VOH to match the motherboard-mounted fan speed monitor requirements, if applicable. Use of the SENSE signal is optional. If the SENSE signal is not used, pin 3 of the connector should be tied to GND.

The power header on the baseboard must be positioned to allow the fan heatsink power cable to reach it. The power header identification and location should be documented in the motherboard documentation or on the motherboard. Figure 37 shows the recommended location of the fan power connector relative to the PGA370 socket. The motherboard power header should be positioned within 4.00 inches (lateral) from the center of the PGA370 socket.

Figure 36. Boxed Processor Fan Heatsink Power Cable Connector Description

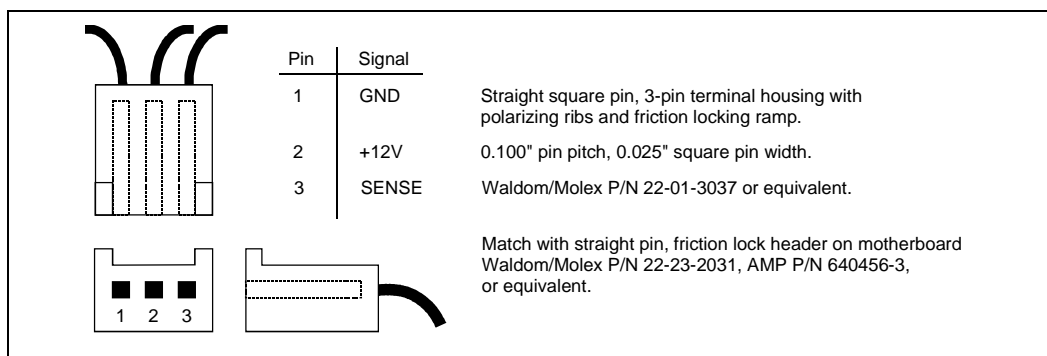
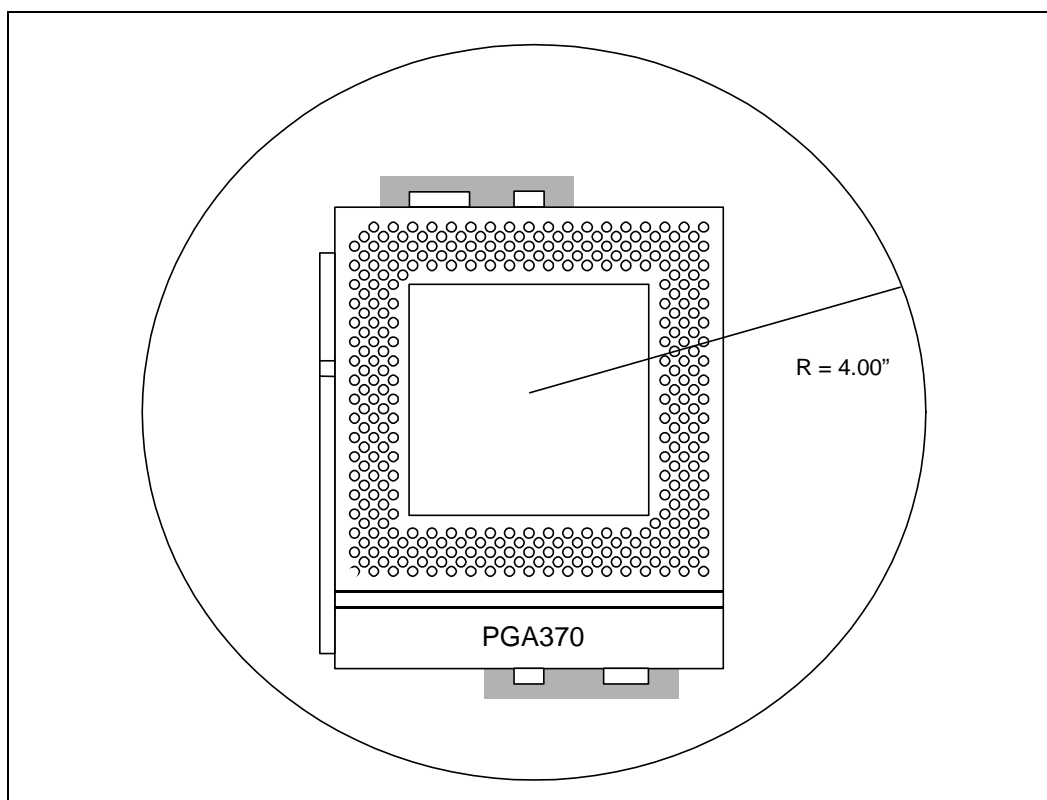

Table 41. Fan Heatsink Power and Signal Specifications

Description	Min	Typ	Max
+12 V: 12 volt fan power supply	10.8 V	12 V	13.2 V
IC: Fan current draw			100 mA
SENSE: SENSE frequency (motherboard should pull this pin up to appropriate Vcc with resistor)		2 pulses per fan revolution	

Figure 37. Motherboard Power Header Placement Relative to the Boxed Intel® Pentium® III Processor



## 7.0 Processor Signal Description

This section provides an alphabetical listing of all the Pentium III processor signals. The tables at the end of this section summarize the signals by direction: output, input, and I/O.

### 7.1 Alphabetical Signals Reference

Table 42. Signal Description (Sheet 1 of 8)

Name	Type	Description
A[35:3]#	I/O	<p>The A[35:3]# (Address) signals define a 2<sup>36</sup>-byte physical memory address space. When ADS# is active, these pins transmit the address of a transaction; when ADS# is inactive, these pins transmit transaction type information. These signals must connect the appropriate pins of all agents on the processor system bus. The A[35:24]# signals are parity-protected by the AP1# parity signal, and the A[23:3]# signals are parity-protected by the AP0# parity signal.</p> <p>On the active-to-inactive transition of RESET#, the processors sample the A[35:3]# pins to determine their power-on configuration. See the <i>Intel® Pentium® II Processor Developer's Manual</i> for details.</p>
A20M#	I	<p>If the A20M# (Address-20 Mask) input signal is asserted, the processor masks physical address bit 20 (A20#) before looking up a line in any internal cache and before driving a read/write transaction on the bus. Asserting A20M# emulates the 8086 processor's address wrap-around at the 1 MB boundary. Assertion of A20M# is only supported in real mode.</p> <p>A20M# is an asynchronous signal. However, to ensure recognition of this signal following an I/O write instruction, it must be valid along with the TRDY# assertion of the corresponding I/O Write bus transaction.</p>
ADS#	I/O	<p>The ADS# (Address Strobe) signal is asserted to indicate the validity of the transaction address on the A[35:3]# pins. All bus agents observe the ADS# activation to begin parity checking, protocol checking, address decode, internal snoop, or deferred reply ID match operations associated with the new transaction. This signal must connect the appropriate pins on all processor system bus agents.</p>
AERR#	I/O	<p>The AERR# (Address Parity Error) signal is observed and driven by all processor system bus agents, and if used, must connect the appropriate pins on all processor system bus agents. AERR# observation is optionally enabled during power-on configuration; if enabled, a valid assertion of AERR# aborts the current transaction.</p> <p>If AERR# observation is disabled during power-on configuration, a central agent may handle an assertion of AERR# as appropriate to the error handling architecture of the system.</p>
AP[1:0]#	I/O	<p>The AP[1:0]# (Address Parity) signals are driven by the request initiator along with ADS#, A[35:3]#, REQ[4:0]#, and RP#. AP1# covers A[35:24]#, and AP0# covers A[23:3]#. A correct parity signal is high if an even number of covered signals are low and low if an odd number of covered signals are low. This allows parity to be high when all the covered signals are high. AP[1:0]# should connect the appropriate pins of all processor system bus agents.</p>
BCLK/BCLK#	I	<p>The BCLK (Bus Clock) signal determines the bus frequency. All processor system bus agents must receive this signal to drive their outputs and latch their inputs on the BCLK rising edge.</p> <p>All external timing parameters are specified with respect to the BCLK signal.</p>

Table 42. Signal Description (Sheet 2 of 8)

Name	Type	Description
BERR#	I/O	<p>The BERR# (Bus Error) signal is asserted to indicate an unrecoverable error without a bus protocol violation. It may be driven by all processor system bus agents, and must connect the appropriate pins of all such agents, if used. However, Pentium III processors do not observe assertions of the BERR# signal.</p> <p>BERR# assertion conditions are configurable at a system level. Assertion options are defined by the following options:</p> <ul style="list-style-type: none"> <li>• Enabled or disabled.</li> <li>• Asserted optionally for internal errors along with IERR#.</li> <li>• Asserted optionally by the request initiator of a bus transaction after it observes an error.</li> <li>• Asserted by any bus agent when it observes an error in a bus transaction.</li> </ul>
BINIT#	I/O	<p>The BINIT# (Bus Initialization) signal may be observed and driven by all processor system bus agents, and if used must connect the appropriate pins of all such agents. If the BINIT# driver is enabled during power on configuration, BINIT# is asserted to signal any bus condition that prevents reliable future information.</p> <p>If BINIT# observation is enabled during power-on configuration, and BINIT# is sampled asserted, all bus state machines are reset and any data which was in transit is lost. All agents reset their rotating ID for bus arbitration to the state after Reset, and internal count information is lost. The L1 and L2 caches are not affected.</p> <p>If BINIT# observation is disabled during power-on configuration, a central agent may handle an assertion of BINIT# as appropriate to the error handling architecture of the system.</p>
BNR#	I/O	<p>The BNR# (Block Next Request) signal is used to assert a bus stall by any bus agent who is unable to accept new bus transactions. During a bus stall, the current bus owner cannot issue any new transactions.</p> <p>Since multiple agents might need to request a bus stall at the same time, BNR# is a wire-OR signal which must connect the appropriate pins of all processor system bus agents. In order to avoid wire-OR glitches associated with simultaneous edge transitions driven by multiple drivers, BNR# is activated on specific clock edges and sampled on specific clock edges.</p>
BP[3:2]#	I/O	The BP[3:2]# (Breakpoint) signals are outputs from the processor that indicate the status of breakpoints.
BPM[1:0]#	I/O	The BPM[1:0]# (Breakpoint Monitor) signals are breakpoint and performance monitor signals. They are outputs from the processor which indicate the status of breakpoints and programmable counters used for monitoring processor performance.
BPRI#	I	The BPRI# (Bus Priority Request) signal is used to arbitrate for ownership of the processor system bus. It must connect the appropriate pins of all processor system bus agents. Observing BPRI# active (as asserted by the priority agent) causes all other agents to stop issuing new requests, unless such requests are part of an ongoing locked operation. The priority agent keeps BPRI# asserted until all of its requests are completed, then releases the bus by deasserting BPRI#.

Table 42. Signal Description (Sheet 3 of 8)

Name	Type	Description															
BR0# BR1#	I/O I	<p>The BR0# and BR1# (Bus Request) pins drive the BREQ[1:0]# signals in the system. The BREQ[1:0]# signals are interconnected in a rotating manner to individual processor pins. The table below gives the rotating interconnect between the processor and bus signals.</p> <p>BR0# (I/O) and BR1# Signals Rotating Interconnect</p> <table border="1"> <thead> <tr> <th>Bus Signal</th> <th>Agent 0 Pins</th> <th>Agent 1 Pins</th> </tr> </thead> <tbody> <tr> <td>BREQ0#</td> <td>BR0#</td> <td>BR1#</td> </tr> <tr> <td>BREQ1#</td> <td>BR1#</td> <td>BR0#</td> </tr> </tbody> </table> <p>During power-up configuration, the central agent must assert the BR0# bus signal. All symmetric agents sample their BR[1:0]# pins on active-to-inactive transition of RESET#. The pin on which the agent samples an active level determines its symmetric agent ID. All agents then configure their pins to match the appropriate bus signal protocol, as shown below.</p> <p><b>BR[1:0]# Signal Agent IDs</b></p> <table border="1"> <thead> <tr> <th>Pin Sampled Active in RESET#</th> <th>Agent ID</th> </tr> </thead> <tbody> <tr> <td>BR0#</td> <td>0</td> </tr> <tr> <td>BR1#</td> <td>3</td> </tr> </tbody> </table>	Bus Signal	Agent 0 Pins	Agent 1 Pins	BREQ0#	BR0#	BR1#	BREQ1#	BR1#	BR0#	Pin Sampled Active in RESET#	Agent ID	BR0#	0	BR1#	3
Bus Signal	Agent 0 Pins	Agent 1 Pins															
BREQ0#	BR0#	BR1#															
BREQ1#	BR1#	BR0#															
Pin Sampled Active in RESET#	Agent ID																
BR0#	0																
BR1#	3																
BSEL[1:0]	I/O	<p>These signals are used to select the system bus frequency. A BSEL[1:0] = "01" selects a 100 MHz system bus frequency and a BSEL[1:0] = "11" selects a 133 MHz system bus frequency. The frequency is determined by the processor(s), chipset, and frequency synthesizer capabilities. All system bus agents must operate at the same frequency. The Pentium III processor for the PGA370 socket operates at 100 MHz and 133 MHz system bus frequencies. Individual processors will only operate at their specified front side bus (FSB) frequency. Either 100 MHz or 133 MHz, not both.</p> <p>On motherboards which support operation at either 66 MHz or 100 MHz, a BSEL[1:0] = "x0" will select a 66 Mhz system bus frequency. 66 MHz operation is not support by the Pentium III processor for the PGA370 socket; therefore, BSEL0 is ignored.</p> <p>These signals must be pulled up to 2.5 V or 3.3V with 1 KΩ resistors and provided as a frequency selection signal to the clock driver/synthesizer. If the system motherboard is not capable of operating at 133 MHz, it should ground the BSEL1 signal and generate a 100 MHz system bus frequency. See <a href="#">Section 2.8.2</a> for implementation examples.</p>															
CLKREF	I	<p>The CLKREF input is a filtered 1.25 V supply voltage for the processor PLL. A voltage divider and decoupling solution is provided by the motherboard. See the design guide for implementation details.</p>															

Table 42. Signal Description (Sheet 4 of 8)

Name	Type	Description												
CPUPRES#	O	<p>The CPUPRES# signal is defined to allow a system design to detect the presence of a terminator device or processor in a PGA370 socket. Combined with the VID combination of VID[3:0]= 1111 (see Section 2.6), a system can determine if a socket is occupied, and whether a processor core is present. See the table below for states and values for determining the presence of a device.</p> <p>PGA370 Socket Occupation Truth Table</p> <table border="1"> <thead> <tr> <th>Signal</th> <th>Value</th> <th>Status</th> </tr> </thead> <tbody> <tr> <td>CPUPRES# VID[3:0]</td> <td>0 Anything other than '1111'</td> <td>Processor core installed in the PGA370 socket.</td> </tr> <tr> <td>CPUPRES# VID[3:0]</td> <td>0 1111</td> <td>Terminator device installed in the PGA370 socket (i.e., no core present).</td> </tr> <tr> <td>CPUPRES# VID[3:0]</td> <td>1 Any value</td> <td>PGA370 socket not occupied.</td> </tr> </tbody> </table>	Signal	Value	Status	CPUPRES# VID[3:0]	0 Anything other than '1111'	Processor core installed in the PGA370 socket.	CPUPRES# VID[3:0]	0 1111	Terminator device installed in the PGA370 socket (i.e., no core present).	CPUPRES# VID[3:0]	1 Any value	PGA370 socket not occupied.
Signal	Value	Status												
CPUPRES# VID[3:0]	0 Anything other than '1111'	Processor core installed in the PGA370 socket.												
CPUPRES# VID[3:0]	0 1111	Terminator device installed in the PGA370 socket (i.e., no core present).												
CPUPRES# VID[3:0]	1 Any value	PGA370 socket not occupied.												
D[63:0]#	I/O	The D[63:0]# (Data) signals are the data signals. These signals provide a 64-bit data path between the processor system bus agents, and must connect the appropriate pins on all such agents. The data driver asserts DRDY# to indicate a valid data transfer.												
DBSY#	I/O	The DBSY# (Data Bus Busy) signal is asserted by the agent responsible for driving data on the processor system bus to indicate that the data bus is in use. The data bus is released after DBSY# is deasserted. This signal must connect the appropriate pins on all processor system bus agents.												
DEFER#	I	The DEFER# signal is asserted by an agent to indicate that a transaction cannot be guaranteed in-order completion. Assertion of DEFER# is normally the responsibility of the addressed memory or I/O agent. This signal must connect the appropriate pins of all processor system bus agents.												
DEP[7:0]#	I/O	The DEP[7:0]# (Data Bus ECC Protection) signals provide optional ECC protection for the data bus. They are driven by the agent responsible for driving D[63:0]#, and must connect the appropriate pins of all processor system bus agents which use them. The DEP[7:0]# signals are enabled or disabled for ECC protection during power on configuration.												
DRDY#	I/O	The DRDY# (Data Ready) signal is asserted by the data driver on each data transfer, indicating valid data on the data bus. In a multi-cycle data transfer, DRDY# may be deasserted to insert idle clocks. This signal must connect the appropriate pins of all processor system bus agents.												
EDGCTRL	O	The EDGCTRL input adjusts the edge rate of AGTL+ output buffers for previous processors and should be pulled up to V <sub>CC</sub> CORE with a 51 Ω ±5% resistor. See the platform design guide for implementation details. This signal is not used by the Pentium III processor.												
FERR#	O	The FERR# (Floating-point Error) signal is asserted when the processor detects an unmasked floating-point error. FERR# is similar to the ERROR# signal on the Intel387™ coprocessor, and is included for compatibility with systems using MS-DOS*-type floating-point error reporting.												



Table 42. Signal Description (Sheet 5 of 8)

Name	Type	Description
FLUSH#	I	<p>When the FLUSH# input signal is asserted, processors write back all data in the Modified state from their internal caches and invalidate all internal cache lines. At the completion of this operation, the processor issues a Flush Acknowledge transaction. The processor does not cache any new data while the FLUSH# signal remains asserted.</p> <p>FLUSH# is an asynchronous signal. However, to ensure recognition of this signal following an I/O write instruction, it must be valid along with the TRDY# assertion of the corresponding I/O Write bus transaction.</p> <p>On the active-to-inactive transition of RESET#, each processor samples FLUSH# to determine its power-on configuration. See the <i>P6 Family of Processors Hardware Developer's Manual</i> for details.</p>
HIT# HITM#	I/O I/O	<p>The HIT# (Snoop Hit) and HITM# (Hit Modified) signals convey transaction snoop operation results, and must connect the appropriate pins of all processor system bus agents. Any such agent may assert both HIT# and HITM# together to indicate that it requires a snoop stall, which can be continued by reasserting HIT# and HITM# together.</p>
IERR#	O	<p>The IERR# (Internal Error) signal is asserted by a processor as the result of an internal error. Assertion of IERR# is usually accompanied by a SHUTDOWN transaction on the processor system bus. This transaction may optionally be converted to an external error signal (e.g., NMI) by system core logic. The processor will keep IERR# asserted until the assertion of RESET#, BINIT#, or INIT#.</p>
IGNNE#	I	<p>The IGNNE# (Ignore Numeric Error) signal is asserted to force the processor to ignore a numeric error and continue to execute noncontrol floating-point instructions. If IGNNE# is deasserted, the processor generates an exception on a noncontrol floating-point instruction if a previous floating-point instruction caused an error. IGNNE# has no effect when the NE bit in control register 0 is set.</p> <p>IGNNE# is an asynchronous signal. However, to ensure recognition of this signal following an I/O write instruction, it must be valid along with the TRDY# assertion of the corresponding I/O Write bus transaction.</p>
INIT#	I	<p>The INIT# (Initialization) signal, when asserted, resets integer registers inside all processors without affecting their internal (L1 or L2) caches or floating-point registers. Each processor then begins execution at the power-on Reset vector configured during power-on configuration. The processor continues to handle snoop requests during INIT# assertion. INIT# is an asynchronous signal and must connect the appropriate pins of all processor system bus agents.</p> <p>If INIT# is sampled active on the active to inactive transition of RESET#, then the processor executes its Built-in Self-Test (BIST).</p>
LINT[1:0]	I	<p>The LINT[1:0] (Local APIC Interrupt) signals must connect the appropriate pins of all APIC Bus agents, including all processors and the core logic or I/O APIC component. When the APIC is disabled, the LINT0 signal becomes INTR, a maskable interrupt request signal, and LINT1 becomes NMI, a nonmaskable interrupt. INTR and NMI are backward compatible with the signals of those names on the Pentium processor. Both signals are asynchronous.</p> <p>Both of these signals must be software configured via BIOS programming of the APIC register space to be used either as NMI/INTR or LINT[1:0]. Because the APIC is enabled by default after Reset, operation of these pins as LINT[1:0] is the default configuration.</p>
LOCK#	I/O	<p>The LOCK# signal indicates to the system that a transaction must occur atomically. This signal must connect the appropriate pins of all processor system bus agents. For a locked sequence of transactions, LOCK# is asserted from the beginning of the first transaction end of the last transaction.</p> <p>When the priority agent asserts BPRI# to arbitrate for ownership of the processor system bus, it will wait until it observes LOCK# deasserted. This enables symmetric agents to retain ownership of the processor system bus throughout the bus locked operation and ensure the atomicity of lock.</p>

Table 42. Signal Description (Sheet 6 of 8)

Name	Type	Description
PICCLK	I	The PICCLK (APIC Clock) signal is an input clock to the processor and core logic or I/O APIC which is required for operation of all processors, core logic, and I/O APIC components on the APIC bus.
PICD[1:0]	I/O	The PICD[1:0] (APIC Data) signals are used for bidirectional serial message passing on the APIC bus, and must connect the appropriate pins of all processors and core logic or I/O APIC components on the APIC bus.
PLL1, PLL2	I	All Pentium III processors have an internal analog PLL clock generator that requires a quiet power supply. PLL1 and PLL2 are inputs to this PLL and must be connected to VCC <sub>CORE</sub> through a low pass filter that minimizes jitter. See the platform design guide for implementation details.
PRDY#	O	The PRDY (Probe Ready) signal is a processor output used by debug tools to determine processor debug readiness.
PREQ#	I	The PREQ# (Probe Request) signal is used by debug tools to request debug operation of the processors.
PWRGOOD	I	<p>The PWRGOOD (Power Good) signal is processor input. The processor requires this signal to be a clean indication that the clocks and power supplies (VCC<sub>CORE</sub>, etc.) are stable and within their specifications. Clean implies that the signal will remain low (capable of sinking leakage current), without glitches, from the time that the power supplies are turned on until they come within specification. The signal must then transition monotonically to a high state. The figure below illustrates the relationship of PWRGOOD to other system signals. PWRGOOD can be driven inactive at any time, but clocks and power must again be stable before a subsequent rising edge of PWRGOOD. It must also meet the minimum pulse width specification in Table 19, and be followed by a 1 ms RESET# pulse.</p> <p>The PWRGOOD signal must be supplied to the processor; it is used to protect internal circuits against voltage sequencing issues. It should be driven high throughout boundary scan operation.</p>
REQ[4:0]#	I/O	The REQ[4:0]# (Request Command) signals must connect the appropriate pins of all processor system bus agents. They are asserted by the current bus owner over two clock cycles to define the currently active transaction type.
RESET#	I	<p>Asserting the RESET# signal resets all processors to known states and invalidates their L1 and L2 caches without writing back any of their contents. For a power-on Reset, RESET# must stay active for at least one millisecond after VCC<sub>CORE</sub> and CLK have reached their proper specifications. On observing active RESET#, all processor system bus agents will deassert their outputs within two clocks.</p> <p>A number of bus signals are sampled at the active-to-inactive transition of RESET# for power-on configuration. These configuration options are described in the <i>P6 Family of Processors Hardware Developer's Manual</i> for details.</p> <p>The processor may have its outputs tristated via power-on configuration. Otherwise, if INIT# is sampled active during the active-to-inactive transition of RESET#, the processor will execute its Built-in Self-Test (BIST). Whether or not BIST is executed, the processor will begin program execution at the power on Reset vector (default 0_FFFF_FFF0h). RESET# must connect the appropriate pins of all processor system bus agents.</p>
RESET2#	I	The RESET2# pin is provided for compatibility with other Intel Architecture processors. The Pentium III processor does not use the RESET2# pin. Refer to the platform design guide for the proper connections of this signal.
RP#	I/O	<p>The RP# (Request Parity) signal is driven by the request initiator, and provides parity protection on ADS# and REQ[4:0]#. It must connect the appropriate pins of all processor system bus agents.</p> <p>A correct parity signal is high if an even number of covered signals are low and low if an odd number of covered signals are low. This definition allows parity to be high when all covered signals are high.</p>
RS[2:0]#	I	The RS[2:0]# (Response Status) signals are driven by the response agent (the agent responsible for completion of the current transaction), and must connect the appropriate pins of all processor system bus agents.

Table 42. Signal Description (Sheet 7 of 8)

Name	Type	Description
RSP#	I	The RSP# (Response Parity) signal is driven by the response agent (the agent responsible for completion of the current transaction) during assertion of RS[2:0]#, the signals for which RSP# provides parity protection. It must connect the appropriate pins of all processor system bus agents. A correct parity signal is high if an even number of covered signals are low and low if an odd number of covered signals are low. While RS[2:0]# = 000, RSP# is also high, since this indicates it is not being driven by any agent guaranteeing correct parity.
RTTCTRL	I	The RTTCTRL input signal provides AGTL+ termination control. The Pentium III processor samples this input to sense the presence of motherboard AGTL+ termination. See the platform design guide for implementation details.
SLEWCTRL	I	The SLEWCTRL input signal provides AGTL+ slew rate control. The Pentium III processor samples this input to determine the slew rate for AGTL+ signals when it is the driving agent. See the platform design guide for implementation details.
SLP#	I	The SLP# (Sleep) signal, when asserted in Stop-Grant state, causes processors to enter the Sleep state. During Sleep state, the processor stops providing internal clock signals to all units, leaving only the Phase-Locked Loop (PLL) still operating. Processors in this state will not recognize snoops or interrupts. The processor will recognize only assertions of the SLP#, STPCLK#, and RESET# signals while in Sleep state. If SLP# is deasserted, the processor exits Sleep state and returns to Stop-Grant state, restarting its internal clock signals to the bus and APIC processor core units.
SMI#	I	The SMI# (System Management Interrupt) signal is asserted asynchronously by system logic. On accepting a System Management Interrupt, processors save the current state and enter System Management Mode (SMM). An SMI Acknowledge transaction is issued, and the processor begins program execution from the SMM handler.
STPCLK#	I	The STPCLK# (Stop Clock) signal, when asserted, causes processors to enter a low power Stop-Grant state. The processor issues a Stop-Grant Acknowledge transaction, and stops providing internal clock signals to all processor core units except the bus and APIC units. The processor continues to snoop bus transactions and latch interrupts while in Stop-Grant state. When STPCLK# is deasserted, the processor restarts its internal clock to all units, services pending interrupts while in the Stop-Grant state, and resumes execution. The assertion of STPCLK# has no effect on the bus clock; STPCLK# is an asynchronous input.
THERMDN	O	Thermal Diode Cathode. Used to calculate core (junction) temperature. See <a href="#">Section 4.3</a> .
THERMDP	I	Thermal Diode Anode. Used to calculate core (junction) temperature. See <a href="#">Section 4.3</a> .
THERMTRIP#	O	The processor protects itself from catastrophic overheating by use of an internal thermal sensor. This sensor is set well above the normal operating temperature to ensure that there are no false trips. The processor will stop all execution when the junction temperature exceeds approximately 135 °C. This is signaled to the system by the THERMTRIP# (Thermal Trip) pin. Once activated, the signal remains latched, and the processor stopped, until RESET# goes active. There is no hysteresis built into the thermal sensor itself; as long as the die temperature drops below the trip level, a RESET# pulse will reset the processor and execution will continue. If the temperature has not dropped below the trip level, the processor will continue to drive THERMTRIP# and remain stopped. The system designer should not act upon THERMTRIP# until after RESET# input is de-asserted since, until this time, the THERMTRIP# output is indeterminate.
TRDY#	I	The TRDY# (Target Ready) signal is asserted by the target to indicate that it is ready to receive a write or implicit writeback data transfer. TRDY# must connect the appropriate pins of all processor system bus agents.

Table 42. Signal Description (Sheet 8 of 8)

Name	Type	Description
VID[3:0]	O	The VID[3:0] (Voltage ID) pins can be used to support automatic selection of power supply voltages. These pins are not signals, but are either an open circuit or a short circuit to VSS on the processor. The combination of opens and shorts defines the voltage required by the processor. The VID pins are needed to cleanly support voltage specification variations on processors. See Table 2 for definitions of these pins. The power supply must supply the voltage that is requested by these pins, or disable itself.
VCORE <sub>DET</sub>	O	The V <sub>COREDET</sub> pin indicate the type of processor core present. This pin will float for 2.0 V V <sub>CCCORE</sub> based processor and will be shorted to VSS for the Pentium III processor.
VCC <sub>1.5</sub>	I	The VCC <sub>1.5</sub> V input pin provides the termination voltage for CMOS signals interfacing to the processor. The Pentium III processor reroutes the 1.5 V input to the VCC <sub>CMOS</sub> output via the package. The supply for VCC <sub>1.5</sub> V must be the same one used to supply VTT.
VCC <sub>2.5</sub>	I	The VCC <sub>2.5</sub> V input pin provides the termination voltage for CMOS signals interfacing to processors which require 2.5 V termination on the CMOS signals. This signal is not used by the Pentium III processor.
VCC <sub>CMOS</sub>	O	The VccCMOS pin provides the CMOS voltage for use by the platform and is used for terminating CMOS signals that interface to the processor.
V <sub>REF</sub>	I	The V <sub>REF</sub> input pins supply the AGTL+ reference voltage, which is typically 2/3 of VTT. V <sub>REF</sub> is used by the AGTL+ receivers to determine if a signal is a logical 0 or a logical 1.

## 7.2 Signal Summaries

Table 43 through Table 46 list attributes of the processor output, input, and I/O signals.

Table 43. Output Signals

Name	Active Level	Clock	Signal Group
CPUPRES#	Low	Asynch	Power/Other
EDGCTRL	N/A	Asynch	Power/Other
FERR#	Low	Asynch	CMOS Output
IERR#	Low	Asynch	CMOS Output
PRDY#	Low	BCLK	AGTL+ Output
THERMTRIP#	Low	Asynch	CMOS Output
VCORE <sub>DET</sub>	N/A	Asynch	Power/Other
VID[3:0]	N/A	Asynch	Power/Other

Table 44. Input Signals (Sheet 1 of 2)

Name	Active Level	Clock	Signal Group	Qualified
A20M#	Low	Asynch	CMOS Input	Always <sup>1</sup>
BCLK	High	—	System Bus Clock	Always
BPRI#	Low	BCLK	AGTL+ Input	Always
BR1#	Low	BCLK	AGTL+ Input	Always

Table 44. Input Signals (Sheet 2 of 2)

Name	Active Level	Clock	Signal Group	Qualified
DEFER#	Low	BCLK	AGTL+ Input	Always
FLUSH#	Low	Asynch	CMOS Input	Always <sup>1</sup>
IGNNE#	Low	Asynch	CMOS Input	Always <sup>1</sup>
INIT#	Low	Asynch	CMOS Input	Always <sup>1</sup>
INTR	High	Asynch	CMOS Input	APIC disabled mode
LINT[1:0]	High	Asynch	CMOS Input	APIC enabled mode
NMI	High	Asynch	CMOS Input	APIC disabled mode
PICCLK	High	—	APIC Clock	Always
PREQ#	Low	Asynch	CMOS Input	Always
PWRGOOD	High	Asynch	CMOS Input	Always
RESET#	Low	BCLK	AGTL+ Input	Always
RS[2:0]#	Low	BCLK	AGTL+ Input	Always
RSP#	Low	BCLK	AGTL+ Input	Always
RTTCTRL	N/A	Asynch	Power/Other	
SLEWCTRL	N/A	Asynch	Power/Other	
SLP#	Low	Asynch	CMOS Input	During Stop-Grant state
SMI#	Low	Asynch	CMOS Input	
STPCLK#	Low	Asynch	CMOS Input	
TRDY#	Low	BCLK	AGTL+ Input	

**NOTE:**

1. Synchronous assertion with active TDRY# ensures synchronization.

Table 45. Input/Output Signals (Single Driver)

Name	Active Level	Clock	Signal Group	Qualified
A[35:3]#	Low	BCLK	AGTL+ I/O	ADS#, ADS#+1
ADS#	Low	BCLK	AGTL+ I/O	Always
AP[1:0]#	Low	BCLK	AGTL+ I/O	ADS#, ADS#+1
BP[3:2]#	Low	BCLK	AGTL+ I/O	Always
BPM[1:0]#	Low	BCLK	AGTL+ I/O	Always
BR0#	Low	BCLK	AGTL+ I/O	Always
BSEL[1:0]	High	Asynch	Power/Other	Always
D[63:0]#	Low	BCLK	AGTL+ I/O	DRDY#
DBSY#	Low	BCLK	AGTL+ I/O	Always
DEP[7:0]#	Low	BCLK	AGTL+ I/O	DRDY#
DRDY#	Low	BCLK	AGTL+ I/O	Always
LOCK#	Low	BCLK	AGTL+ I/O	Always
REQ[4:0]#	Low	BCLK	AGTL+ I/O	ADS#, ADS#+1
RP#	Low	BCLK	AGTL+ I/O	ADS#, ADS#+1

Table 46. Input/Output Signals (Multiple Driver)

Name	Active Level	Clock	Signal Group	Qualified
AERR#	Low	BCLK	AGTL+ I/O	ADS#+3
BERR#	Low	BCLK	AGTL+ I/O	Always
BINIT#	Low	BCLK	AGTL+ I/O	Always
BNR#	Low	BCLK	AGTL+ I/O	Always
HIT#	Low	BCLK	AGTL+ I/O	Always
HITM#	Low	BCLK	AGTL+ I/O	Always
PICD[1:0]	High	PICCLK	APIC I/O	Always