

## FEATURES

ADP1047/ADP1048 Daughter Card with I2C interface  
Retrofit controller to any topology or existing design  
Software GUI  
Low component count

## ADP1047/ADP1048 EVALUATION BOARD OVERVIEW

The daughter card evaluation board allows the ADP1047/ADP1048 to be quickly evaluated in any existing switching power supply application. Using the daughter card and its accompanying software, the IC can be interfaced to any PC running Windows 2000/NT/XP/Vista/7 via the computers USB port.

The daughter card can be connected to any existing ADP1047/ADP1048 evaluation board or reference design.

It can also be connected to any power supply as a replacement for the existing controller. The daughter card has a connector through which the pin outs of the ADP1047/ADP1048 can be probed. The software GUI allows control and read/write functionality of the ADP1047/adp1048 internal registers to modify, for example, the PWM settings or over current protection limits.

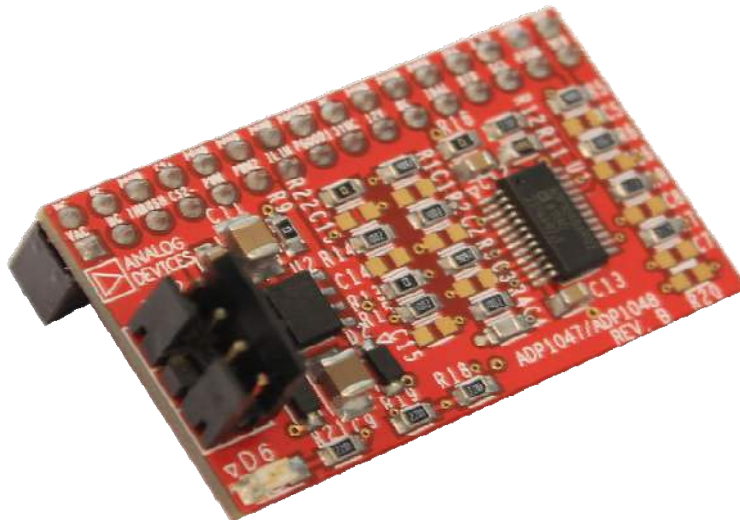

Figure 1 - Daughter card with pin outs of ADP1047/ADP1048

### Rev. 1.0

Reference designs are as supplied "as is" and without warranties of any kind, express, implied, or statutory including, but not limited to, any implied warranty of merchantability or fitness for a particular purpose. No license is granted by implication or otherwise under any patents or other intellectual property by application or use of reference designs. Information furnished by Analog Devices is believed to be accurate and reliable. However, no responsibility is assumed by Analog Devices for its use, nor for any infringements of patents or other rights of third parties that may result from its use. Analog Devices reserves the right to change devices or specifications at any time without notice. Trademarks and registered trademarks are the property of their respective owners. Reference designs are not authorized to be used in life support devices or systems.

**TABLE OF CONTENTS**

Features ..... 1  
EVALUATION BOARD HARDWARE.....3  
CONNECTORS.....4  
REFURNISHING AND EXISTING DESIGN WITH ADP1047/ADP1048 DAUGHTER CARD.....5  
Additional key points and checklist:.....6  
    SCHEMATIC.....7  
LAYOUT .....8  
BILL OF MATERIALS ..... 11  
Notes..... 12

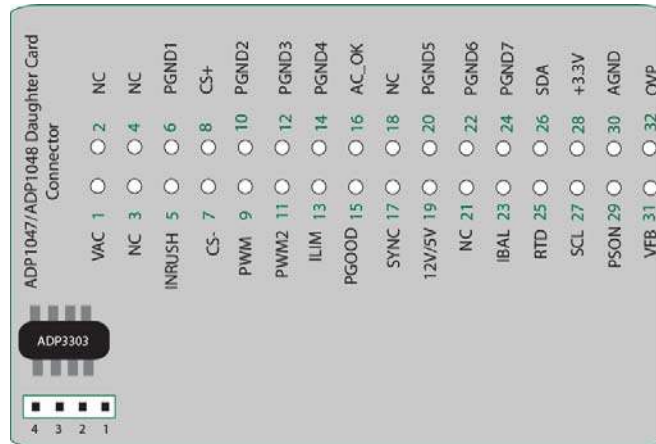

Figure 2 - Simplified Block Diagram

## EVALUATION BOARD HARDWARE

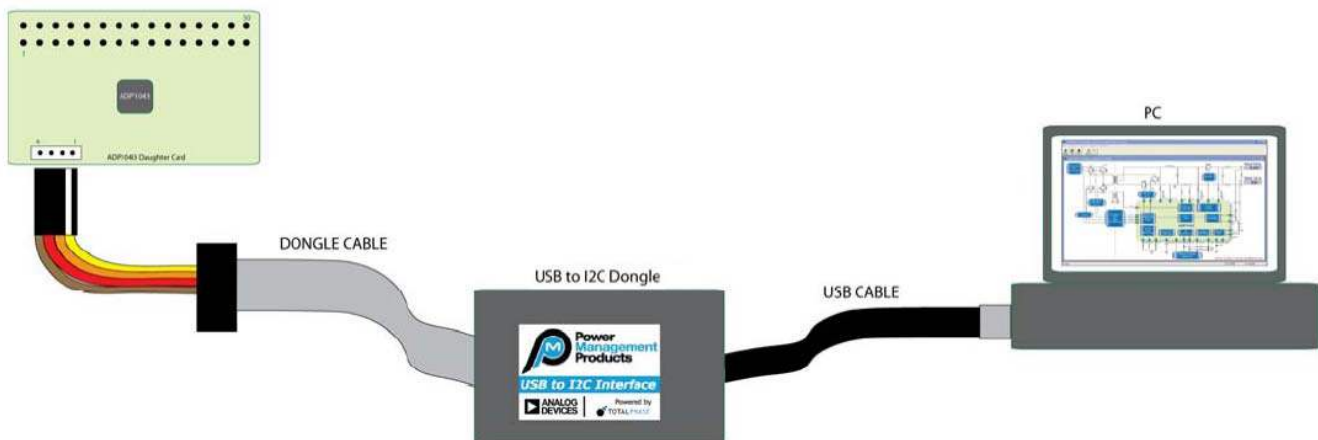

Figure 3 - Connection diagram of daughter card to PC via I2C interface (USB dongle)

## CONNECTORS

The pin outs of the USB interface are given below:



Pin	Evaluation Board Function
1	5V
2	SCL
3	SDA
4	Ground

Table 1 - I2C connector pin out descriptions

Figure 4 – I2C connector (pin1 on left)

ADP1047/ADP1048 Daughter Card Connector			
VAC	1	2	NC
NC	3	4	NC
INRUSH	5	6	PGND1
CS-	7	8	CS+
PWM	9	10	PGND2
PWM2	11	12	PGND3
ILIM	13	14	PGND4
PGOOD	15	16	AC_OK
SYNC	17	18	NC
12V/5V	19	20	PGND5
NC	21	22	PGND6
IBAL	23	24	PGND7
RTD	25	26	SDA
SCL	27	28	+3.3V
PSON	29	30	AGND
VFB	31	32	OVP

Figure 5 - Detailed description of pin outs

## REFURNISHING AND EXISTING DESIGN WITH ADP1047/ADP1048 DAUGHTER CARD

To evaluate the IC with an existing power supply, a jumper cable can be used. Figure 6 and Figure 7 demonstrate how a jumper cable is connected on one end to the daughter card and the other end to the respective function of the pin on the power supply.

Care must be taken to ensure that the traces/wires that are connected at their respective sensing points are short and are not routed through any high frequency traces (switching nodes) of the power stage that would result in poor signal integrity due to noise injection or EMI. A spread of wires must definitely be avoided as this increases the probability of injected noise due to bigger loop areas and common impedance coupling between the power ground and the analog and digital grounds.

Note: The ADP1047/ADP1048 provides control and logic signals for the power switches. External drivers need to be used to turn on/off the switches in the power stage of the design.

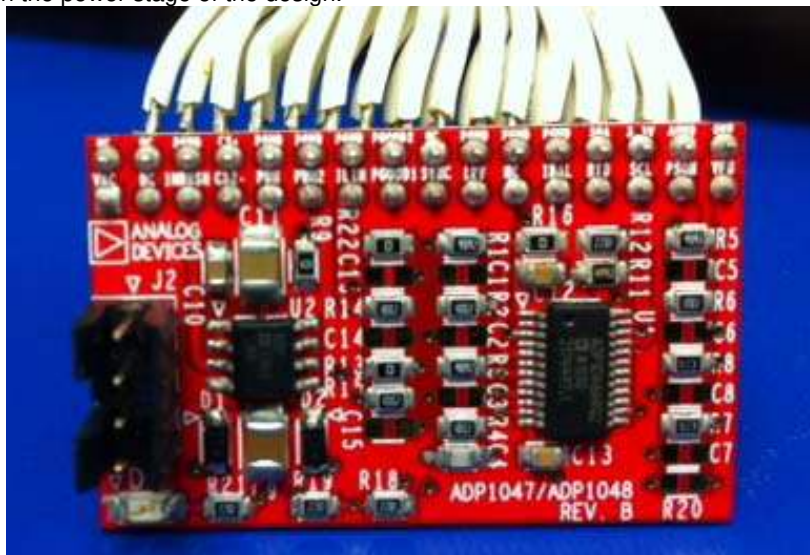

Figure 6 – Daughter card connection

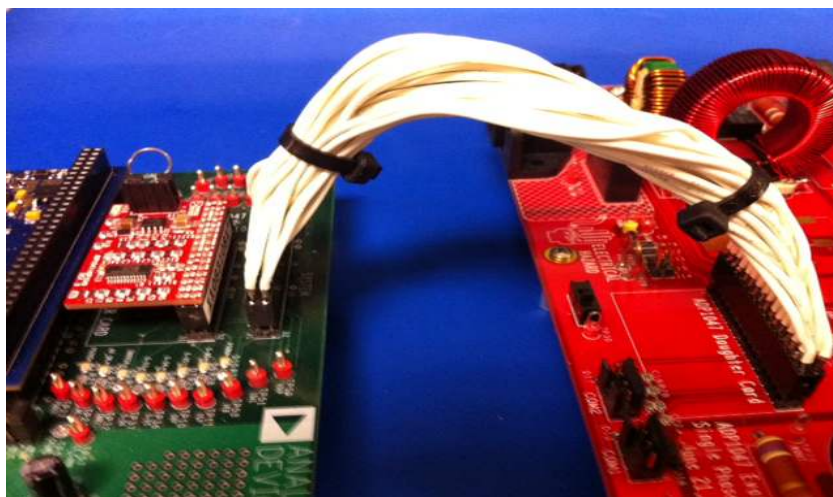

Figure 7 – Example of a retrofitted system with daughter card on left and power stage on the right.

**ADDITIONAL KEY POINTS AND CHECKLIST:**

1. The daughter card is powered using the USB cable. The 3.3V LDO present on the PCB converts the 5V to 3.3V which supplies power to the ADP1047/ADP1048. Alternately an isolated power supply 5V or 12V (referenced to AGND) may be used and connected to pins on the daughter card. The I2C connector also has the SDA and SCL pins which are used for serial communication to the ADP1047/ADP1048 using the software GUI.
2. The RTD pin is referenced to AGND and the thermistor must be ideally placed close to the hottest part of the power stage for monitoring over temperature. Leave open if not used.
3. Connect PS\_ON to 3.3V using a switch or permanently connected to 3.3V. If permanently connected then the power supply can be turned on using software PS\_ON in the GUI.
4. CS+ and CS- (differential input) must be connected across the current sense resistor. Care must be taken not to exceed 150mV as it exceeds the maximum range of the ADC.
5. The voltage dividers with 10 to 1 ratio are on the daughter card for sensing the input voltage VAC and output voltage VFB. The voltage divider combined with the resistor on the main board can provide 1V at the divider at the nominal output voltage to provide enough range for trimming. Care must be taken not to exceed 1.6V as it exceeds the maximum range of the ADC.

SCHEMATIC

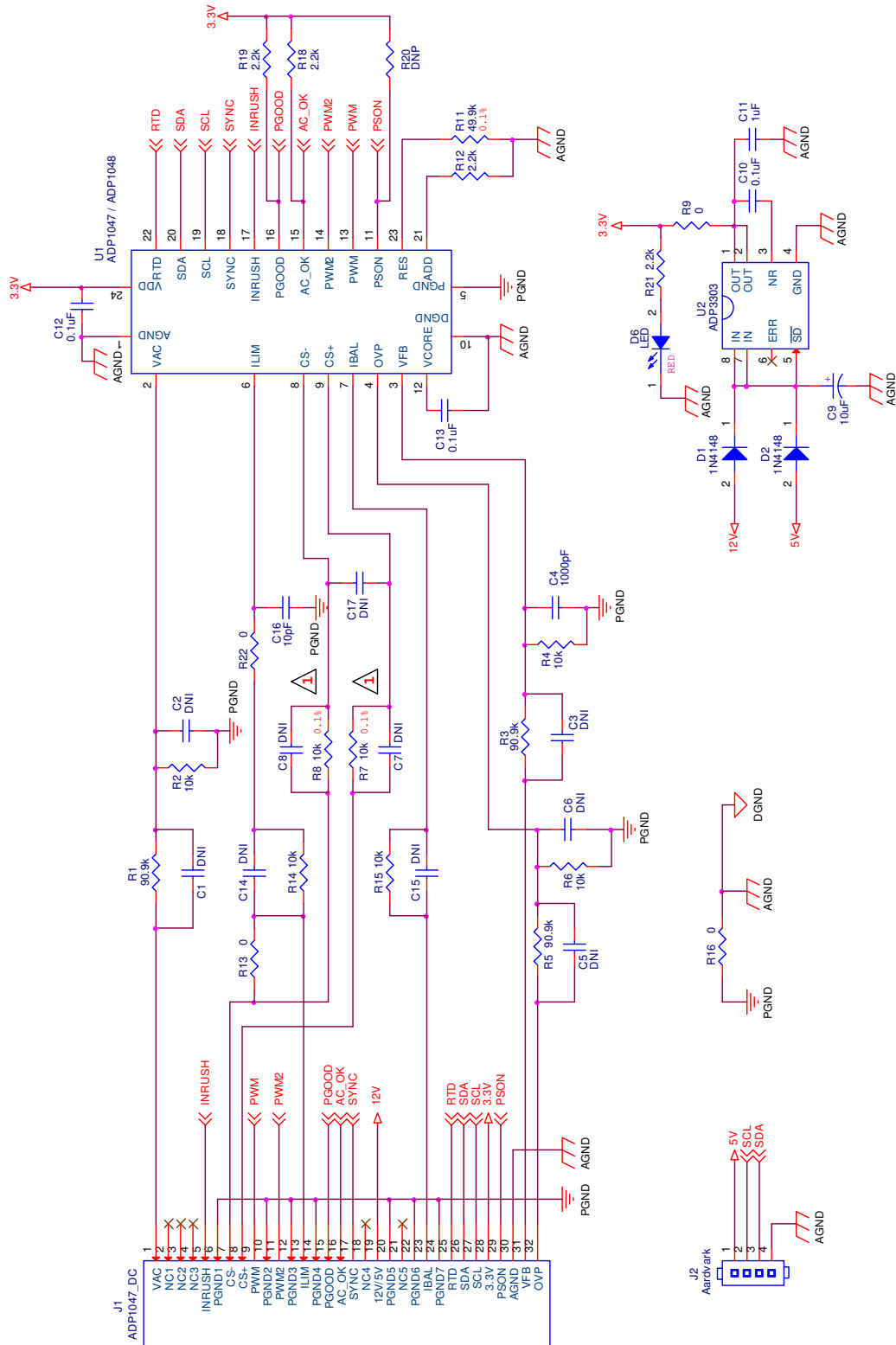

Figure 8 – Daughter card schematic

LAYOUT

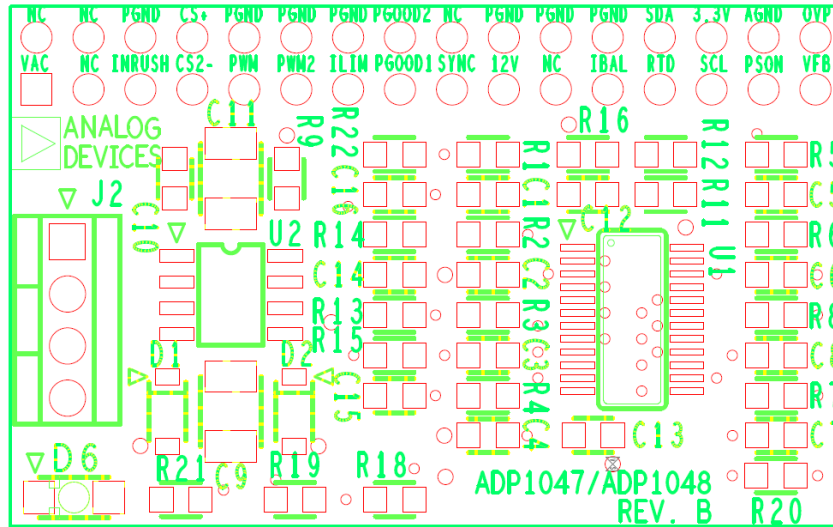

Figure 10 – Top silkscreen

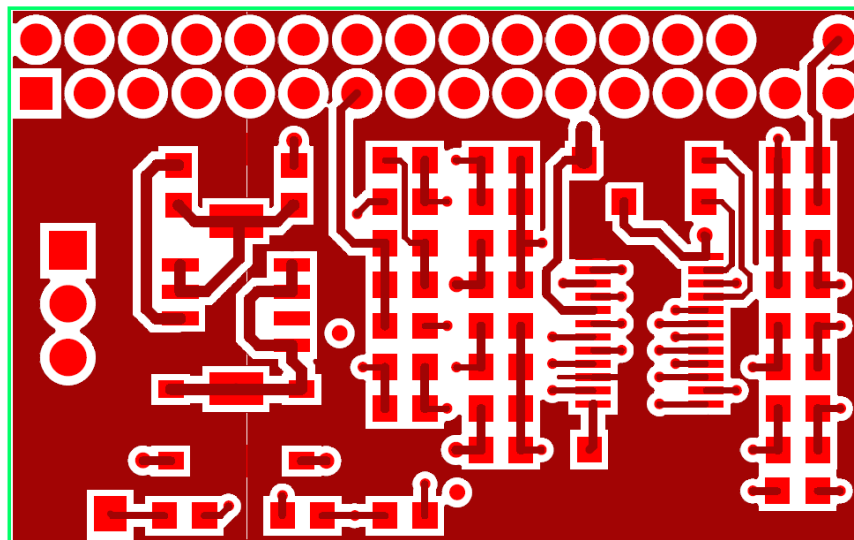

Figure 11 - Top Layer,



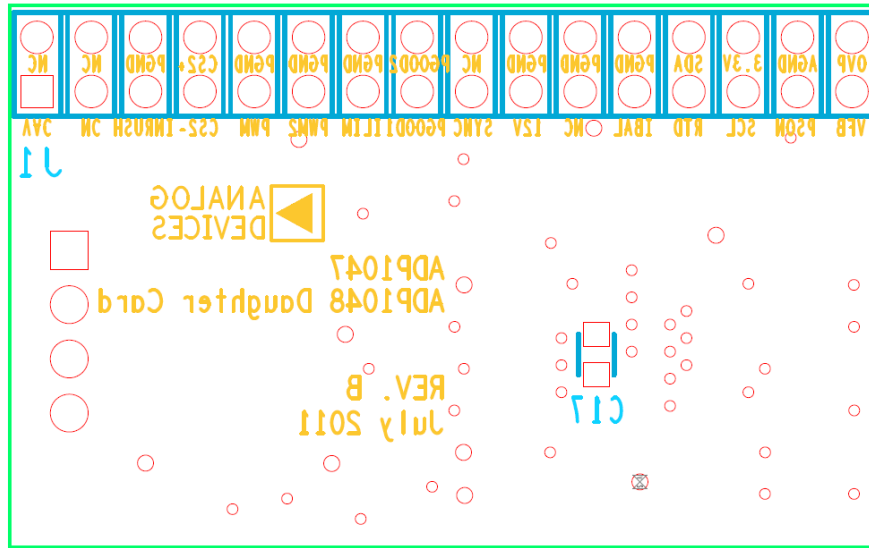

Figure 12 –Bottom Silkscreen

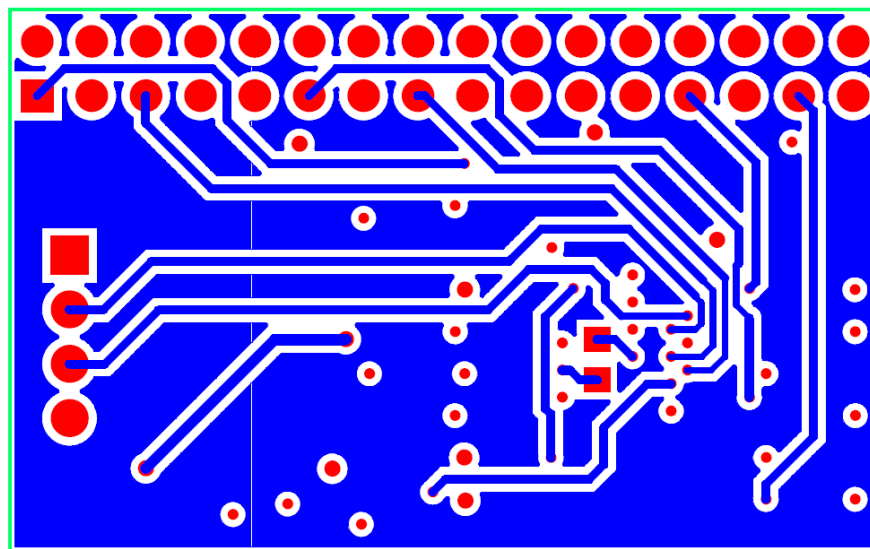

Figure 13 – Bottom layer

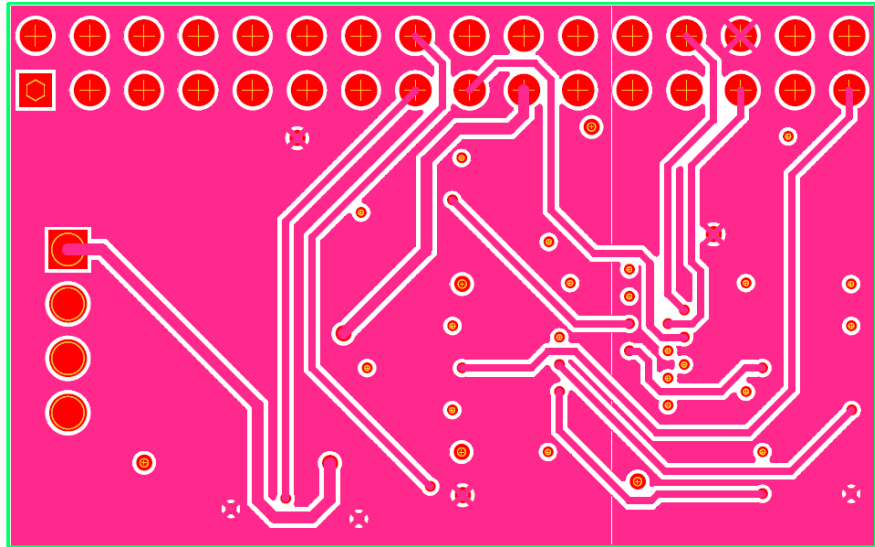

Figure 14 – Inner layer1 layout

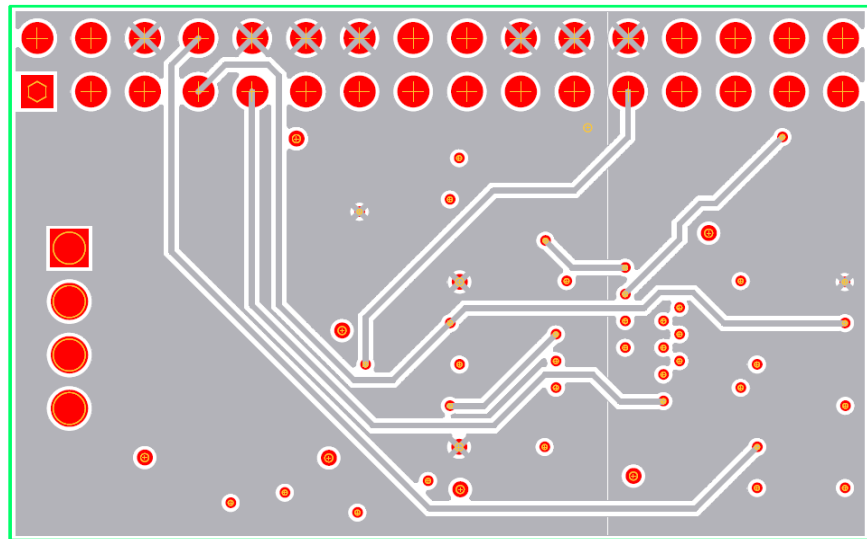

Figure 15– inner layer2 layout

## BILL OF MATERIALS

Part Reference	Part Description	Manufacture	Mfg Part No
C1	DNI		
C2	DNI		
C3	DNI		
C4	CAP CER 1000pF 50V 5% COG	Murata Electronics	GRM2165C1H102JA01D
C5	DNI		
C6	DNI		
C7	DNI		
C8	DNI		
C9	CAP CER 10uF 25V +/-20% X5R	Panasonic - ECG	ECJ-4YB1E106M
C10	CAP CER 0.1uF 50V 10% X7R	Murata Electronics	GRM21BR71H104KA01L
C11	CAP CER 1.0uF 50V 10% X7R	Murata Electronics	GRM32RR71H105KA01L
C12	CAP CER 0.1uF 50V 10% X7R	Murata Electronics	GRM21BR71H104KA01L
C13	CAP CER 0.1uF 50V 10% X7R	Murata Electronics	GRM21BR71H104KA01L
C14	DNI		
C15	DNI		
C16	DNI		
D1	DIODE SWITCH 100V 150MA	Micro Commercial	1N4148WTPMSCT-ND
D2	DIODE SWITCH 100V 150MA	Micro Commercial	1N4148WTPMSCT-ND
D6	LED SUPER RED CLEAR 75MA 1.7V SMD	CHICAGO MINIATURE LIGHTING	CMD15-21SRC/TR8
R1	RES 90.9K OHM 1/8W 1% SMD	Any	
R2	RES 10K OHM 1/8W 1% SMD	Any	
R3	RES 90.9K OHM 1/8W 1% SMD	Any	
R4	RES 10K OHM 1/8W 1% SMD	Any	
R5	RES 90.9K OHM 1/8W 1% SMD	Any	
R6	RES 10K OHM 1/8W 1% SMD	Any	
R7	RES 10K OHM 1/8W 0.1% SMD	Any	
R8	RES 10K OHM 1/8W 0.1% SMD	Any	
R9	RES 0.0 OHM 1/8W 5% SMD	Any	
R11	RES 49.9K OHM 1/8W 0.1% SMD	Any	
R12	RES 2.20K OHM 1/8W 1% SMD	Any	
R13	RES 0.0 OHM 1/8W 5% SMD	Any	
R14	RES 10K OHM 1/8W 1% SMD	Any	
R15	RES 10K OHM 1/8W 1% SMD	Any	
R16	RES 0.0 OHM 1/8W 5% SMD	Any	
R18	RES 2.20K OHM 1/8W 1% SMD	Any	
R19	RES 2.20K OHM 1/8W 1% SMD	Any	
R20	RES 2.20K OHM 1/8W 1% SMD	Any	
R21	RES 2.20K OHM 1/8W 1% SMD	Any	
R22	RES 0.0 OHM 1/8W 5% SMD	Any	
U1	Digital PFC Controller	Analog Devices	ADP1047
U2	Low Dropout Regulators	Analog Devices	ADP3303

**NOTES**