

BGSF110GN26

SP10T Antenna Switch Module with integrated GPIO controller, 2 GSM-TX and 8 TRX Ports for multi-mode GSM/EDGE, WCDMA or LTE applications

Preliminary Datasheet

Rev. 1.3, 2013-03-29

Edition 2013-03-29

**Published by
Infineon Technologies AG
81726 Munich, Germany**

**© 2013 Infineon Technologies AG
All Rights Reserved.**

Legal Disclaimer

The information given in this document shall in no event be regarded as a guarantee of conditions or characteristics. With respect to any examples or hints given herein, any typical values stated herein and/or any information regarding the application of the device, Infineon Technologies hereby disclaims any and all warranties and liabilities of any kind, including without limitation, warranties of non-infringement of intellectual property rights of any third party.

Information

For further information on technology, delivery terms and conditions and prices, please contact the nearest Infineon Technologies Office (www.infineon.com).

Warnings

Due to technical requirements, components may contain dangerous substances. For information on the types in question, please contact the nearest Infineon Technologies Office.

Infineon Technologies components may be used in life-support devices or systems only with the express written approval of Infineon Technologies, if a failure of such components can reasonably be expected to cause the failure of that life-support device or system or to affect the safety or effectiveness of that device or system. Life support devices or systems are intended to be implanted in the human body or to support and/or maintain and sustain and/or protect human life. If they fail, it is reasonable to assume that the health of the user or other persons may be endangered.

Confidential

BGSF110GN26 SP10T Antenna Switch Module with integrated GPIO controller, 2 GSM-TX and 8 TRX Ports for multi-mode GSM/EDGE, WCDMA or LTE applications

Confidential

Revision History: 2013-03-29, Rev. 1.3

Previous Revision:1.1

Page	Subjects (major changes since last revision)
12	Electrical characteristics updated
15	Package outline drawing added

Trademarks of Infineon Technologies AG

AURIX™, C166™, CanPAK™, CIPOST™, CIPURSE™, EconoPACK™, CoolMOS™, CoolSET™, CORECONTROL™, CROSSAVE™, DAVE™, DI-POL™, EasyPIM™, EconoBRIDGE™, EconoDUAL™, EconoPIM™, EconoPACK™, EiceDRIVER™, eupec™, FCOS™, HITFET™, HybridPACK™, I²RF™, ISOFACE™, IsoPACK™, MIPAQ™, ModSTACK™, my-d™, NovalithIC™, OptiMOS™, ORIGAT™, POWERCODE™, PRIMARION™, PrimePACK™, PrimeSTACK™, PRO-SIL™, PROFET™, RASIC™, ReverSave™, SatRIC™, SIEGET™, SINDRION™, SIPMOS™, SmartLEWIS™, SOLID FLASH™, TEMPFET™, thinQ!™, TRENCHSTOP™, TriCore™.

Other Trademarks

Advance Design System™ (ADS) of Agilent Technologies, AMBA™, ARM™, MULTI-ICETM, KEIL™, PRIMECELL™, REALVIEW™, THUMB™, μVision™ of ARM Limited, UK. AUTOSAR™ is licensed by AUTOSAR development partnership. Bluetooth™ of Bluetooth SIG Inc. CAT-ig™ of DECT Forum. COLOSSUS™, FirstGPS™ of Trimble Navigation Ltd. EMV™ of EMVCo, LLC (Visa Holdings Inc.). EPCOS™ of Epcos AG. FLEXGO™ of Microsoft Corporation. FlexRay™ is licensed by FlexRay Consortium. HYPERTERMINAL™ of Hilgraeve Incorporated. IEC™ of Commission Electrotechnique Internationale. IrDA™ of Infrared Data Association Corporation. ISO™ of INTERNATIONAL ORGANIZATION FOR STANDARDIZATION. MATLAB™ of MathWorks, Inc. MAXIM™ of Maxim Integrated Products, Inc. MICROTEC™, NUCLEUS™ of Mentor Graphics Corporation. MIPI™ of MIPI Alliance, Inc. MIPS™ of MIPS Technologies, Inc., USA. muRata™ of MURATA MANUFACTURING CO., MICROWAVE OFFICE™ (MWO) of Applied Wave Research Inc., OmniVision™ of OmniVision Technologies, Inc. Openwave™ Openwave Systems Inc. RED HAT™ Red Hat, Inc. RFMD™ RF Micro Devices, Inc. SIRIUS™ of Sirius Satellite Radio Inc. SOLARIS™ of Sun Microsystems, Inc. SPANSION™ of Spansion LLC Ltd. Symbian™ of Symbian Software Limited. TAIYO YUDEN™ of Taiyo Yuden Co. TEAKLITE™ of CEVA, Inc. TEKTRONIX™ of Tektronix Inc. TOKO™ of TOKO KABUSHIKI KAISHA TA. UNIX™ of X/Open Company Limited. VERILOG™, PALLADIUM™ of Cadence Design Systems, Inc. VLYNQ™ of Texas Instruments Incorporated. VXWORKS™, WIND RIVER™ of WIND RIVER SYSTEMS, INC. ZETEX™ of Diodes Zetex Limited.

Last Trademarks Update 2011-11-11

1 Features

Main Features

- Suitable for multi-mode GSM / EDGE / C2K / WCDMA / LTE applications
- 0.1 to 3.8 GHz coverage
- Ultra-low insertion loss and harmonics generation
- Integrated GSM transmit filters
- 2 high-linearity GSM TX paths
- 8 high-linearity, interchangeable WCDMA TRX ports
- 2 TRX ports also function as high-linearity GSM RX ports
- High port-to-port isolation
- Integrated GPIO decoder supporting logic levels from 1.35 V to 3.1 V
- No decoupling DC capacitors required, if no DC applied on RF lines
- Small form factor 3.4 mm x 2.6 mm x 0.73 mm
- 1kV HBM ESD protection



Description

The BGSF110GN26 is a Single Pole Ten Throw (SP10T) Antenna Switch Module (ASM) optimized for wireless applications up to 3.8 GHz. It is a perfect solution for multi-mode handsets based on quadband GSM, WCDMA and LTE. The switch module configuration is shown in [Figure 1](#).

The module comes in a miniature TSNP package and comprises of a high power CMOS SP10T switch with integrated GPIO controller and harmonic filters for GSM high and low band transmit paths. The on-chip controller integrates CMOS logic and level shifters, driven by control inputs from 1.35 to 3.1 V.

No external DC blocking capacitors are required in typical applications as long as no DC is applied to any RF port.

Product Name	Package	Marking
BGSF110GN26	PG-TSNP-26-2	F10G

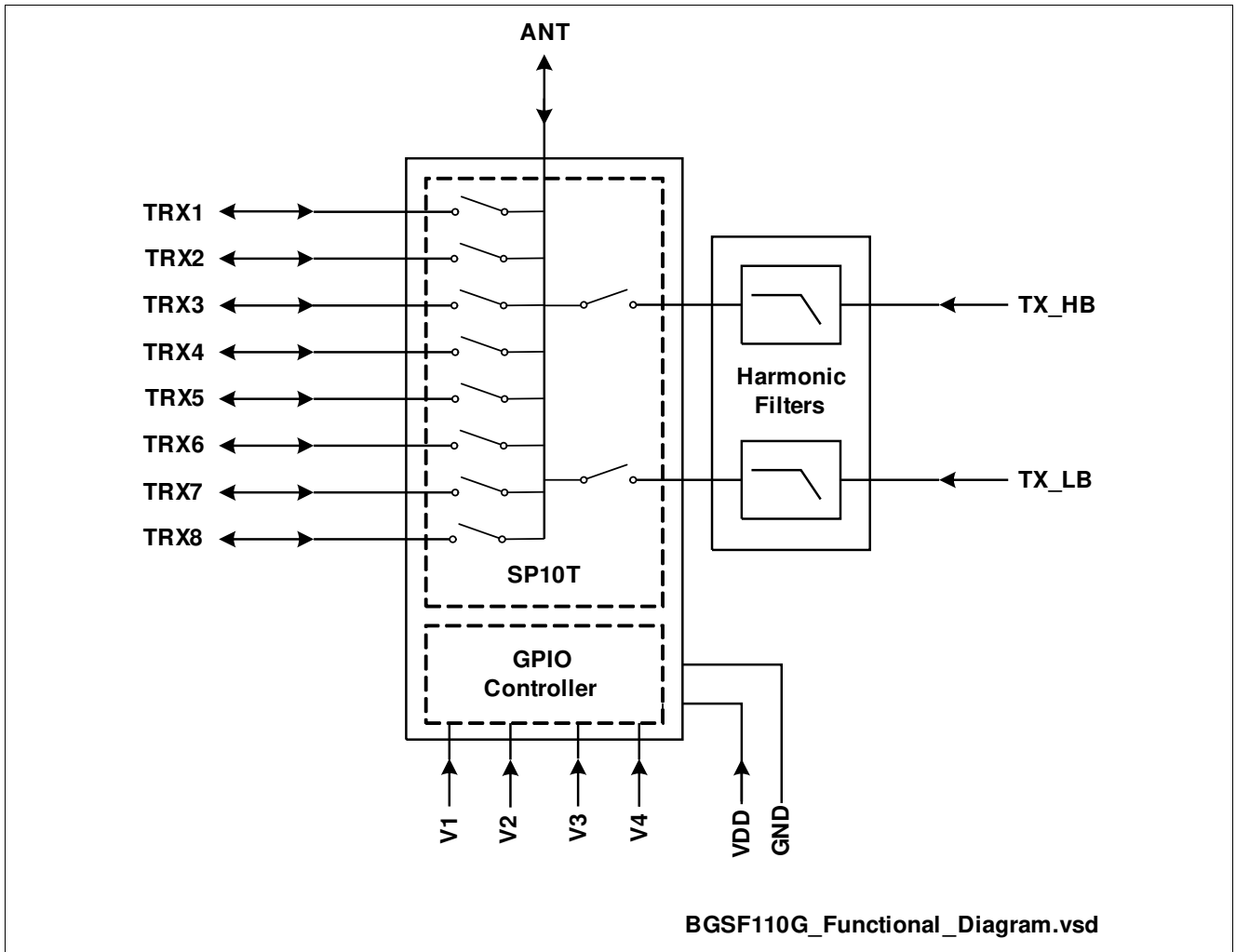

Figure 1 Functional diagram

2 Maximum Ratings

Table 1 Maximum Ratings

Parameter	Symbol	Values			Unit	Note / Test Condition
		Min.	Typ.	Max.		
Supply voltage	V_{dd}	-0.5	–	3.6	V	–
GPIO control voltage levels	V_{CtrlX}	-0.7	–	$V_{dd}+0.7$	V	–
Maximum DC-voltage on RF-ports and RF-grounds	V_{RFDC}	0	–	0	V	–
Storage Temperature Range	T_{stg}	-65	–	150	°C	–
Junction temperature	T_j	–	–	125	°C	–
Thermal resistance junction - soldering point	R_{thJS}	–	32	–	K/W	–
RF input power at all GSM TX ports	P_{RF_TX}	–	–	36	dBm	CW
RF input power at all TRX ports	P_{RF_TRX}	–	–	30	dBm	CW

Table 2 ESD Ratings

Parameter	Symbol	Values			Unit	Note / Test Condition
		Min.	Typ.	Max.		
ESD capability Human Body Model	V_{ESD_HBM}	–	1000	–	V	–
ESD capability ANT port (according IEC 6100-4-2 contact)	V_{ESD_ANT}	–	tbd	–	V	Using external shunt inductor on ANT port

Attention: Stresses above the max. values listed here may cause permanent damage to the device. Exposure to absolute maximum rating conditions for extended periods may affect device reliability. Maximum ratings are absolute ratings; exceeding only one of these values may cause irreversible damage to the integrated circuit.

3 Operation Ranges

Table 3 Operation Ranges

Parameter	Symbol	Values			Unit	Note / Test Condition
		Min.	Typ.	Max.		
Supply Voltage	V_{dd}	2.4	3.0	3.3	V	–
Supply current	I_{dd}	–	100	200	μ A	–
Ambient temperature range	T_A	-30	–	+85	$^{\circ}$ C	–
Extended temperature range	T_E	-40	–	+95	$^{\circ}$ C	Functional only
Control voltage High	V_{CtrlH}	1.35	1.8	V_{dd}	V	–
Control voltage Low	V_{CtrlL}	0	–	0.45	V	–
Input Power						
TRX ports	P_{in_TRX}	–	–	27	dBm	–
GSM TX LB port	$P_{in_GSM_LB}$	–	–	36	dBm	50% duty cycle
GSM TX HB port	$P_{in_GSM_HB}$	–	–	34	dBm	50% duty cycle

4 Electrical Characteristics

Terminating port impedance: $Z_0 = 50 \Omega$

Temperature: $T = -25 \text{ }^\circ\text{C} - +85 \text{ }^\circ\text{C}$

Supply voltage: $V_{dd} = 2.4 \text{ V}.. 3.3 \text{ V}$

Unless otherwise specified

Table 4 RF Characteristics

Parameter	Symbol	Values			Unit	Note / Test Condition
		Min.	Typ.	Max.		
Insertion Loss						
TRX1-8	IL	–	0.50	0.70	dB	698 to 960 MHz
		–	0.58	0.78	dB	1428 to 1990 MHz
		–	0.62	0.82	dB	1990 to 2170 MHz
		–	0.75	1.00	dB	2170 to 2690 MHz
		–	1.12	1.42	dB	2690 to 3500 MHz
		–	1.35	1.63	dB	3600 to 3800 MHz
TXLB	IL	–	0.90	1.20	dB	824 to 915 MHz
TXHB	IL	–	1.00	1.30	dB	1710 to 1910 MHz
Return Loss						
	RL	25	30	–	dB	698 to 960 MHz
		23	27	–	dB	1710 to 1990 MHz
		21	25	–	dB	1990 to 2170 MHz
		18	23	–	dB	2170 to 2690 MHz
		13	16	–	dB	2690 to 3500 MHz
Isolation (f = 698-2690 MHz unless noted otherwise)						
	ISO	32	40	–	dB	TRX1,2,3,7,8 to TRX4,5,6 (f = 698 - 2400 MHz)
		28	32	–	dB	TRX1,2,3,7,8 to TRX4,5,6 (f = 2400- 2690 MHz)
		37	46	–	dB	TX1 to all TRXports (f = 824-915 MHz)
		37	40	–	dB	TX2 to all TRXports (f = 1710-1910 MHz)
		27	37	–	dB	TRX4 to TRX6
		19	25	–	dB	TRX1 to TRX2, TRX2 to TRX3, TRX4 to TRX5, TRX5 to TRX6
		34	35	–	dB	ANT to TRX7 (RX1) (active path: ANT - TRX8) (f = 1805-1910 MHz)
		37	40	–	dB	ANT to TRX8 (RX2) (active path: ANT - TRX7) (f = 1805-1910 MHz)
Switching Time						
On/Off	$t_{on/off}$	–	1	–	μs	90% OFF to 90% ON; 90% ON to 90% OFF

Table 4 RF Characteristics (cont'd)

Parameter	Symbol	Values			Unit	Note / Test Condition
		Min.	Typ.	Max.		
Boost Converter Settling Time	t_{BC}	–	–	25	μs	After power down mode
Intermodulation Distortion (UMTS Band 1, Band 5)						
IMD2, low	IMD2 low	–	-102	-97	dBm	Tx = 20 dBm, Interferer = -15 dBm
IMD2, high	IMD2 high	–	-105	-97	dBm	Tx = 20 dBm, Interferer = -15 dBm
IMD3	IMD3	–	-115	-97	dBm	Tx = 20 dBm, Interferer = -15 dBm
Harmonic Generation up to 12.75 GHz						
TXLB, H2	P_{Harm}	77	88	–	dBc	35 dBm, 50 Ω , 50% duty cycle
TXLB, H3		86	100	–	dBc	35 dBm, 50 Ω , 50% duty cycle
TXHB, H2		82	98	–	dBc	32 dBm, 50 Ω , 50% duty cycle
TXHB, H3		77	82	–	dBc	32 dBm, 50 Ω , 50% duty cycle
TRX1-8, H2		81	88	–	dBc	25 dBm, 50 Ω
TRX1-8, H3		85	97	–	dBc	25 dBm, 50 Ω
Harmonic Attenuation						
TXLB	P_{att}	27	38	–	dB	1648 to 1830 MHz
		27	33	–	dB	2472 to 2745 MHz
		20	27	–	dB	2746 to 12750 MHz
TXHB		27	38	–	dB	3420 to 3820 MHz
		25	30	–	dB	5130 to 5730 MHz
		23	27	–	dB	5731 to 12750 MHz

Note: All electrical characteristics are measured with all RF ports terminated in 50 Ω and recommended circuit.

5 Pin Definition and Package Outline

Table 5 Pin Configuration

Pin No.	Name	Pin Type	Buffer Type	Function
0	GND	GND		Ground, Die Pad
1	GND	GND		RF Ground
2	TRX4	I/O		WCDMA TRX-Port
3	TRX5	I/O		WCDMA TRX-Port
4	TRX6	I/O		WCDMA TRX-Port
5	GND	GND		RF Ground
6	GND	GND		RF Ground
7	ANT	I/O		Antenna Port
8	GND	GND		RF Ground
9	GND	GND		RF Ground
10	TX2	I		GSM HB-Port
11	GND	GND		RF Ground
12	GND	GND		RF Ground
13	TX1	I		GSM LB-Port
14	GND	GND		RF Ground
15	TRX8	I/O		WCDMA TRX-Port (GSM RX-Port)
16	GND	GND		RF Ground
17	TRX7	I/O		WCDMA TRX-Port (GSM RX-Port)
18	TRX1	I/O		WCDMA TRX-Port
19	TRX2	I/O		WCDMA TRX-Port
20	TRX3	I/O		WCDMA TRX-Port
21	GND	GND		DC Ground
22	VDD	PWR		Supply Voltage
23	V4	I		GPIO Control Ping
24	V3	I		GPIO Control Pin
25	V2	I		GPIO Control Pin
26	V1	I		GPIO Control Pin

Table 6 Mechanical Data

Parameter	Symbol	Value	Unit
Package size	Size	3.4 x 2.6	mm
Package height	H	0.73	mm

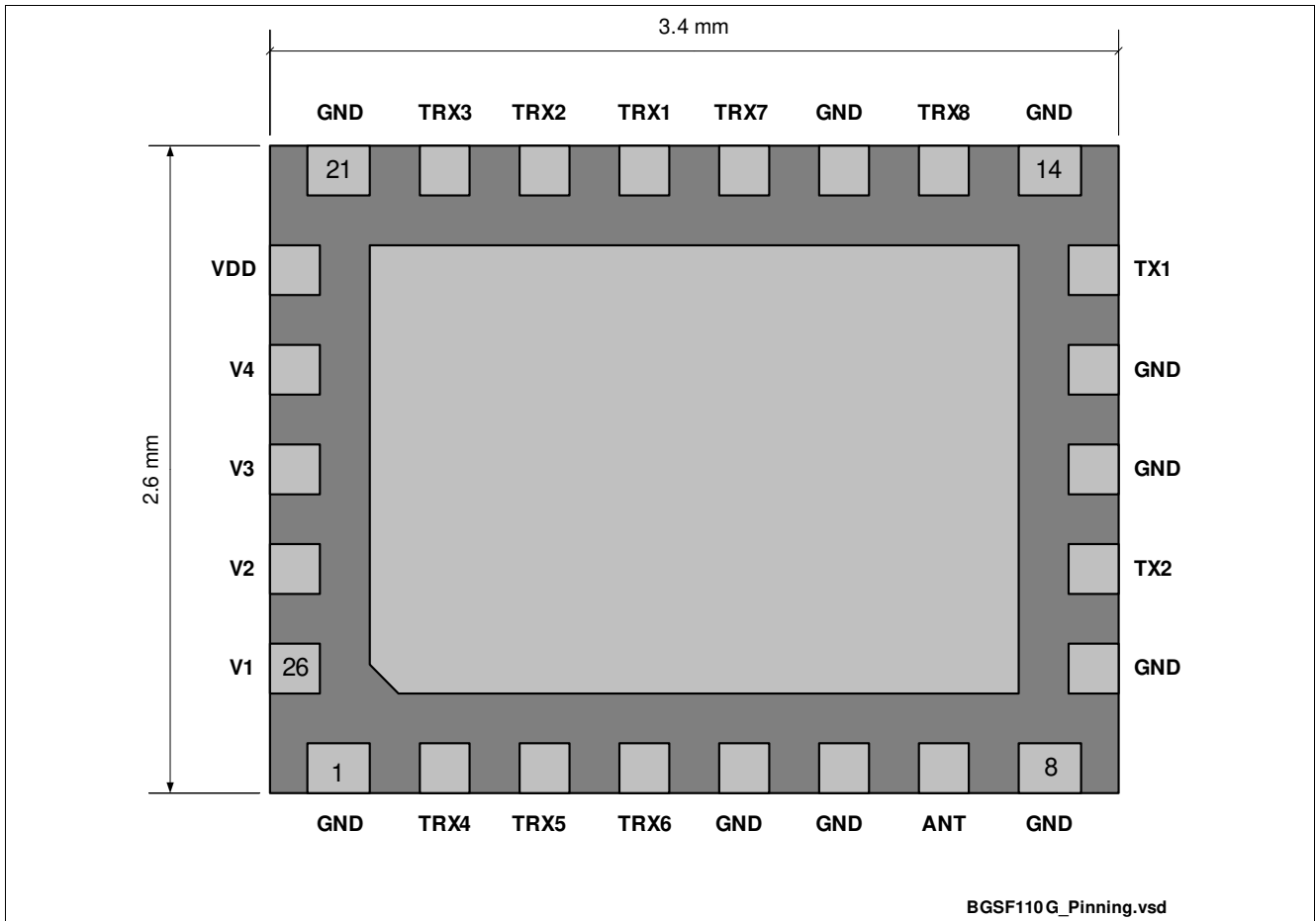

Figure 2 Pin Configuration (Top View)

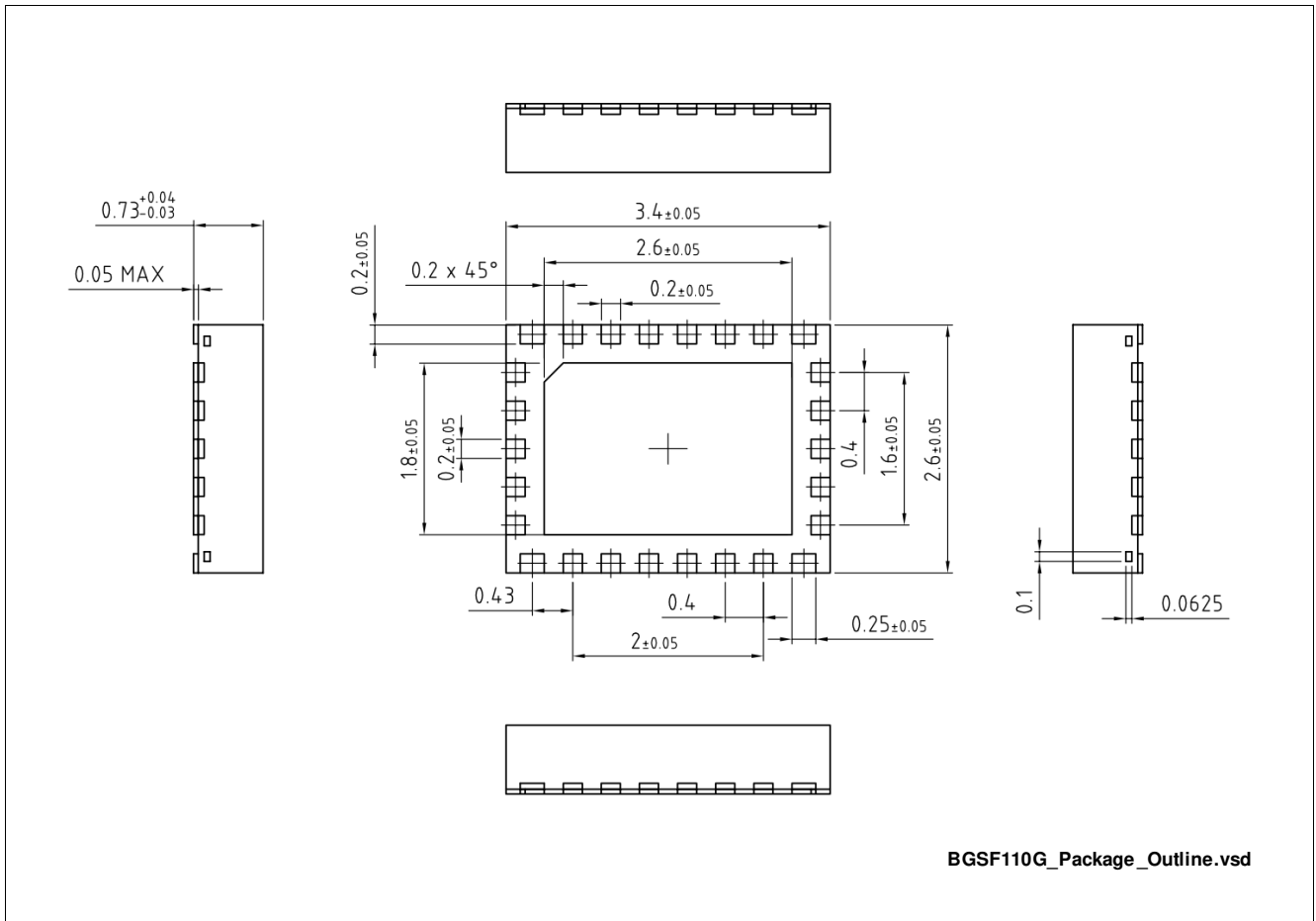

Figure 3 Package Outline

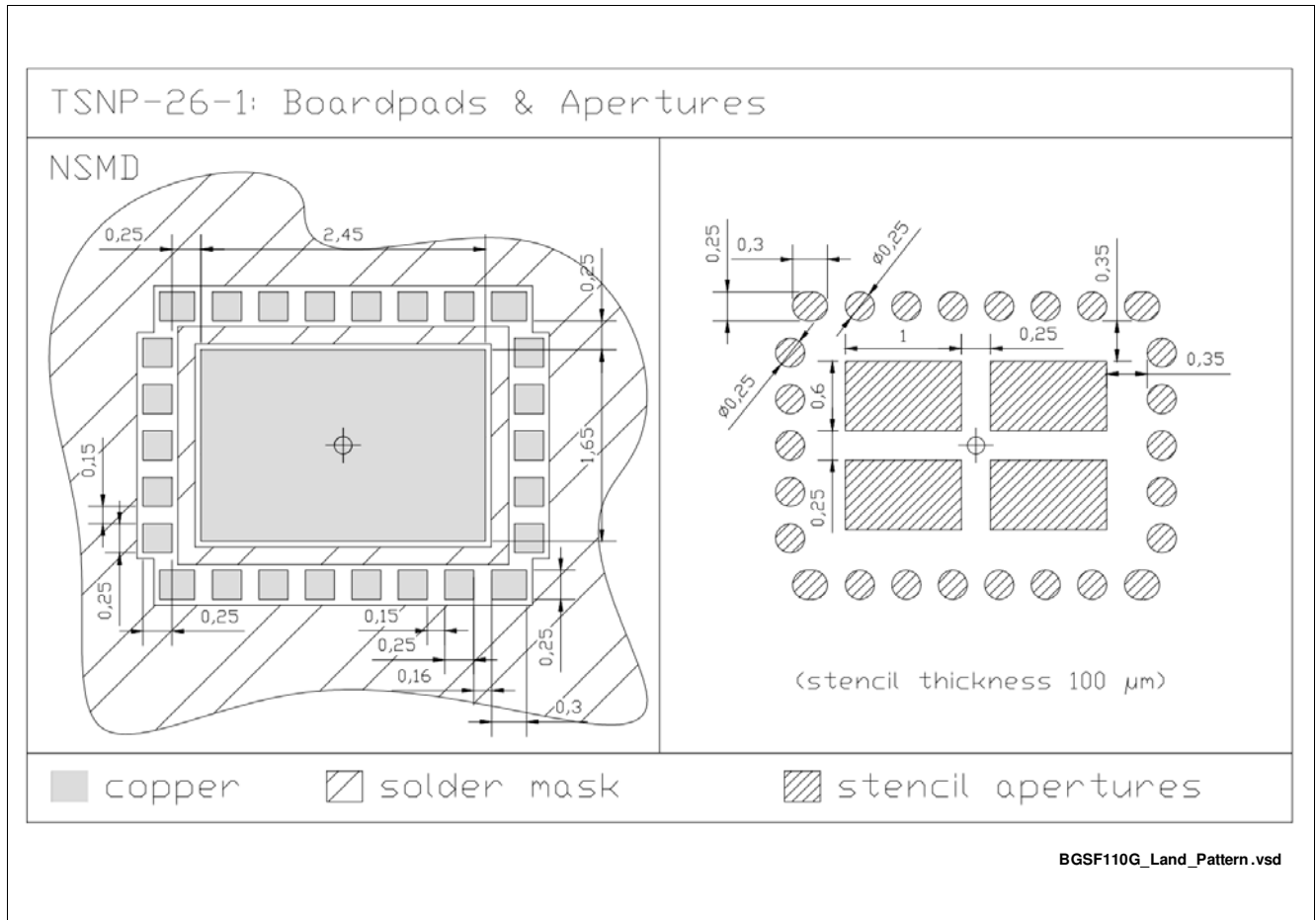

Figure 4 Land pattern

6 Band selection truth table

Table 7 GPIO truth table

Mode	V1	V2	V3	V4
ANT - TXLB	H	H	L	L
ANT - TXHB	H	L	L	L
ANT - TRX1	L	L	H	L
ANT - TRX2	H	L	H	L
ANT - TRX3	H	H	H	L
ANT - TRX4	H	L	H	H
ANT - TRX5	H	H	H	H
ANT - TRX6	H	L	L	H
ANT - TRX7	L	H	H	L
ANT - TRX8	L	H	L	L
Isolation	L	L	L	L

Note: $H = V_{CtrlH}$; $L = V_{CtrlL}$

www.infineon.com

Published by Infineon Technologies AG