

REVISIONS				
P	LTN	DESCRIPTION	DATE	APVD
A6	ECR-21-123293		2FEB2022	RK JB

- NOTES.
- Material:Housing:Aluminium Diecasting Alloy
 - Surface:Varnish grey
 - Varnish on the inside not necessary
 - Packaging
Quantity 5 Pieces in a box
- ⚠️ OBSOLETE PARTS: OBSOLETE CIS STREAMLINING PER D.RENAUD/D.SINISI**

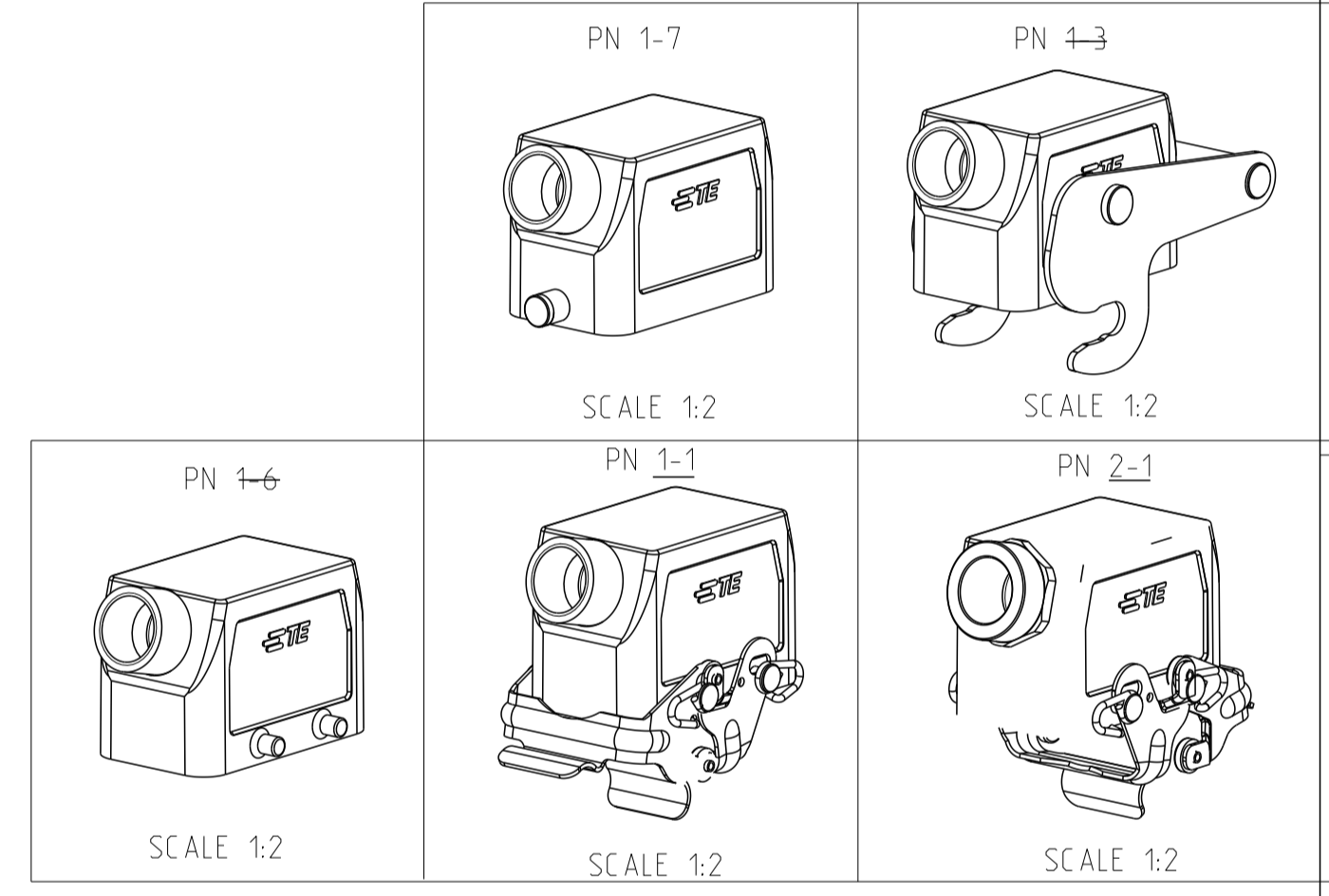

QTY	DESCRIPTION	MATERIAL	SURFACE	COLOR	ITEM NO	NOTES
1	ZB-Central clip	Stainless steel	-		10	
2	LB-Clip bolt	Stainless steel	-		9	
2	LB-Clip bolt	Steel	Zinc plated	Blue	8	
2	VS-Side clip	Stainless steel	-		7	
2	VS-Side clip	Steel	Zinc plated	Blue	6	
4	VS-Clip bolt	Stainless steel	-		5	
1	6-K1-Adaptor PG16	Brass	Nickel plated		4	
1	Adaptor round PG16	Brass	Nickel plated		3	
1	Hood HB.10.Pg.1.16	Aluminium	Aluminium oxide	Blak	2	
1	Hood HB.10.Pg.1.16	Aluminium	-	Grey	1	
1-32-71-72-11-12-61-6	DESCRIPTION	MATERIAL	SURFACE	COLOR	ITEM NO	NOTES
	ORDERING TEXT					
	HB.10.STS.1.16.Z					
	HB-K.10.STS-1.16.Z					
	HB.10.STS-VS-1.16.Z					
	HB-K.10.STS-VS-1.16.Z					
	HB.10.STS-GR.1.16.Z					
	HB-K.10.STS-GR.1.16.Z					
	HB-Z.10.STS-ZB.1.16.Z					

THIS DRAWING IS A CONTROLLED DOCUMENT.

DIMENSIONS: mm
 TOLERANCES UNLESS OTHERWISE SPECIFIED:
 0-100: ±0.1
 100-1000: ±0.2
 ANGLES: ±0.5°

DWG: 03.03.99
 CHK: 03.03.99
 APVD:

NAME: Hood HB.10.Sts.1.16.Z
 PRODUCT SPEC:
 APPLICATION SPEC:
 WEIGHT:
 CUSTOMER DRAWING

SCALE: 1:1
 SHEET: 1 OF 1
 REV: A6

STE TE Connectivity