

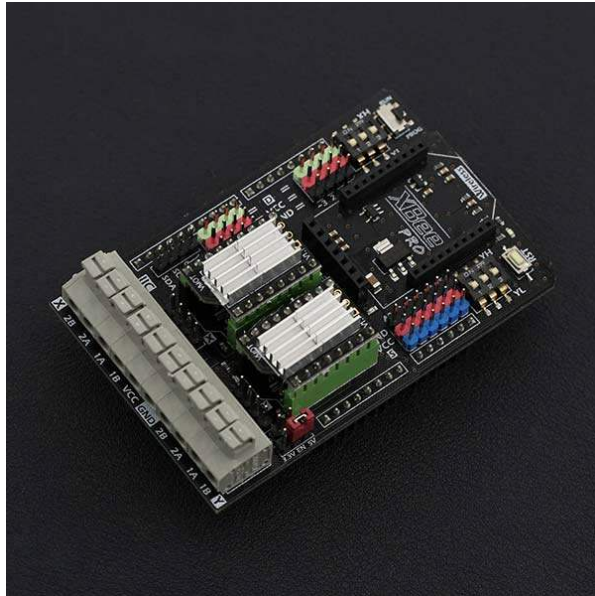

## Stepper Motor Shield For Arduino(DRV8825) SKU:DRI0023

From Robot Wiki



Stepper Motor Shield For Arduino

### Contents

- 1 Introduction
- 2 Specification
- 3 Pin Out& Diagram
- 4 Sample code

### Introduction

Do you want to do some projects with stepper motors such as a drafting instrument, a 3D printer, an auto curtain, etc...? As we all know, regular stepper motors are hard to drive, but with this stepper motor shield, you can easily drive 2 stepper motors via just 6 digital I/O's. This board is compatible with the Arduino UNO R3. Directly supports Xbee and Xbee form factor Wi-Fi, Bluetooth and RF modules. Easy connection of cables via screwless PC terminals. Each stepper motor has a code switch for adjusting driving modes, to obtain different rotational speeds. Interfaces of the board include extension 6 channel Analog I/O, 8 channel Digital I/O & I2C. Stepper motor is a brushless DC electric motor that divides a full rotation into a number of equal steps. The motor's position can then be commanded to move and hold at one of these steps without any feedback sensor (an open-loop controller), as long as the motor is carefully sized to the application in respect to torque and speed.

## Specification

- Support 3.3V and 5V operating voltage
- Suitable for two-phase and four-wire stepper motor
- Board with two DRV8825 driver chip and a heat sink has been mounted.
- Input Voltage : 8.2-45V DC (Just power the stepper motor driver), 1.6A output current per coil
- Driving Pins: D4,D5,D6,D7,D8,D12
- Squeeze connector, quite easy and convenient.
- 8 channel digital I/O pins & 6 channel Analog input pins
- DRV8825 Microstepping bipolar stepper motor driver
- Six different microstep resolutions (full-step, 1/2-step, 1/4-step, 1/8-step, 1/16-step, 1/32-step)
- Compatible with Arduino UNO R3, Leonardo, Mega and other controllers, with full port extensions. Support XBee, XBee Wi-Fi, Bluetooth and RF modules, ensure that the needs of your wireless communications.
- There is a switch on the board Xbee wireless interfaces corner. PROG stop wireless module, available USB programming. RUN time can use the wireless communication module.

## Pin Out& Diagram

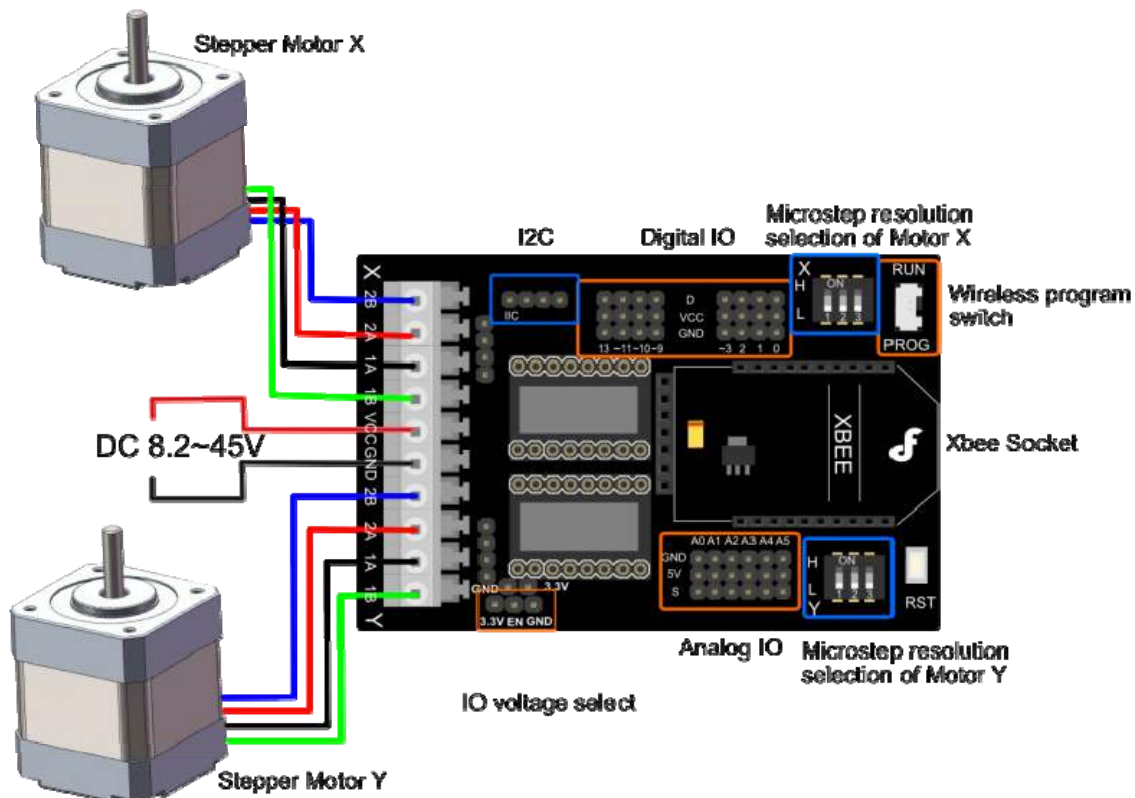

Stepper Motor Shield For Arduino(DRV8825)

- Wireless program switch:
  - **RUN:** Turn the Switch here to use the Xbee module
  - **PROG:** Turn the Switch here to upload the sketch via USB
- Motor wiring diagram :

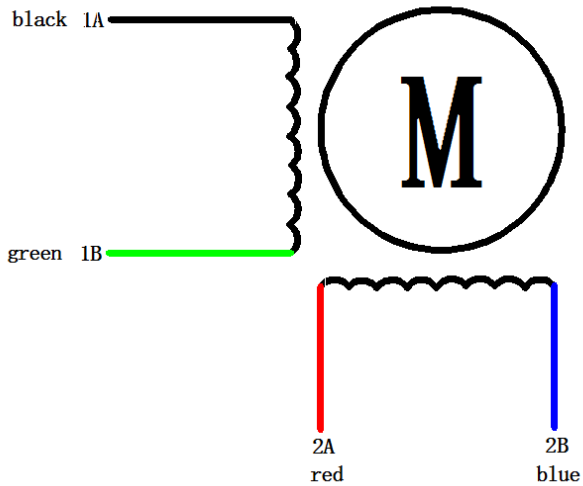

Motor wiring diagram

- The new version expand two enable pins, you can enable/disable the motor driver to save the power consumption, Motor X enable pin for the D8, Motor Y enable pin for the D12, low voltage enable, the following truth table:

D8	D12	M1	M2
Low	Low	ENABLE	ENABLE
High	Low	DISENABLE	ENABLE
Low	High	ENABLE	DISENABLE
High	High	DISENABLE	DISENABLE

- Dip switch settings for Microstep resolution:

MS1	MS2	MS3	Microstep Resolution
Low	Low	Low	Full step
High	Low	Low	Half step
Low	High	Low	1/4 step
High	High	Low	1/8 step
Low	Low	High	1/16 step
High	Low	High	1/32 step
Low	High	High	1/32 step
High	High	High	1/32 step

- IO voltage select
  - Change the the position of the jumper cap according to your Main board operating voltage.

More details

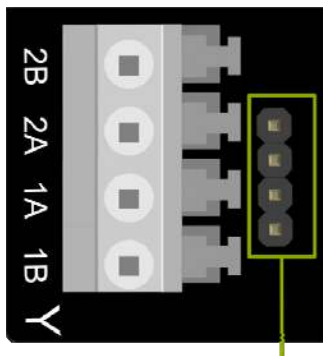

**Other form of connector  
to stepper motor**

- Squeeze connector makes connection easily and quickly.
- The other form of connector for XH2.54 or female headers

## Sample code

```
/*
This sample code is for testing the 2 stepper motors
The rotation velocity can be adjusted by the code switch
Microcontroller: Arduino UNO
*/
int M1dirpin = 7; //Motor X direction pin
int M1steppin = 6; //Motor X step pin
int M1en=8; //Motor X enable pin
int M2dirpin = 4; //Motor Y direction pin
int M2steppin = 5; //Motor Y step pin
int M2en=12; //Motor Y enable pin

void setup()
{
  pinMode(M1dirpin,OUTPUT);
  pinMode(M1steppin,OUTPUT);
  pinMode(M1en,OUTPUT);
  pinMode(M2dirpin,OUTPUT);
  pinMode(M2steppin,OUTPUT);
  pinMode(M2en,OUTPUT);

  digitalWrite(M1en,LOW);// Low Level Enable
  digitalWrite(M2en,LOW);// Low Level Enable
}
void loop()
{
  int j;
  delayMicroseconds(2);
  digitalWrite(M1dirpin,LOW);
  digitalWrite(M2dirpin,LOW);
  for(j=0;j<=5000;j++){
    digitalWrite(M1steppin,LOW);
```

```
digitalWrite (M2steppin, LOW);  
delayMicroseconds (2);  
digitalWrite (M1steppin, HIGH); //Rising step  
digitalWrite (M2steppin, HIGH);  
delay (1);  
}
```

```
}
```

For any question/advice/cool idea to share, please visit [DFRobot Forum](#).