

REVISIONS				
P	LTN	DESCRIPTION	DATE	OWN APVD
A		INITIAL RELEASE	11MAY2022	LL DZ

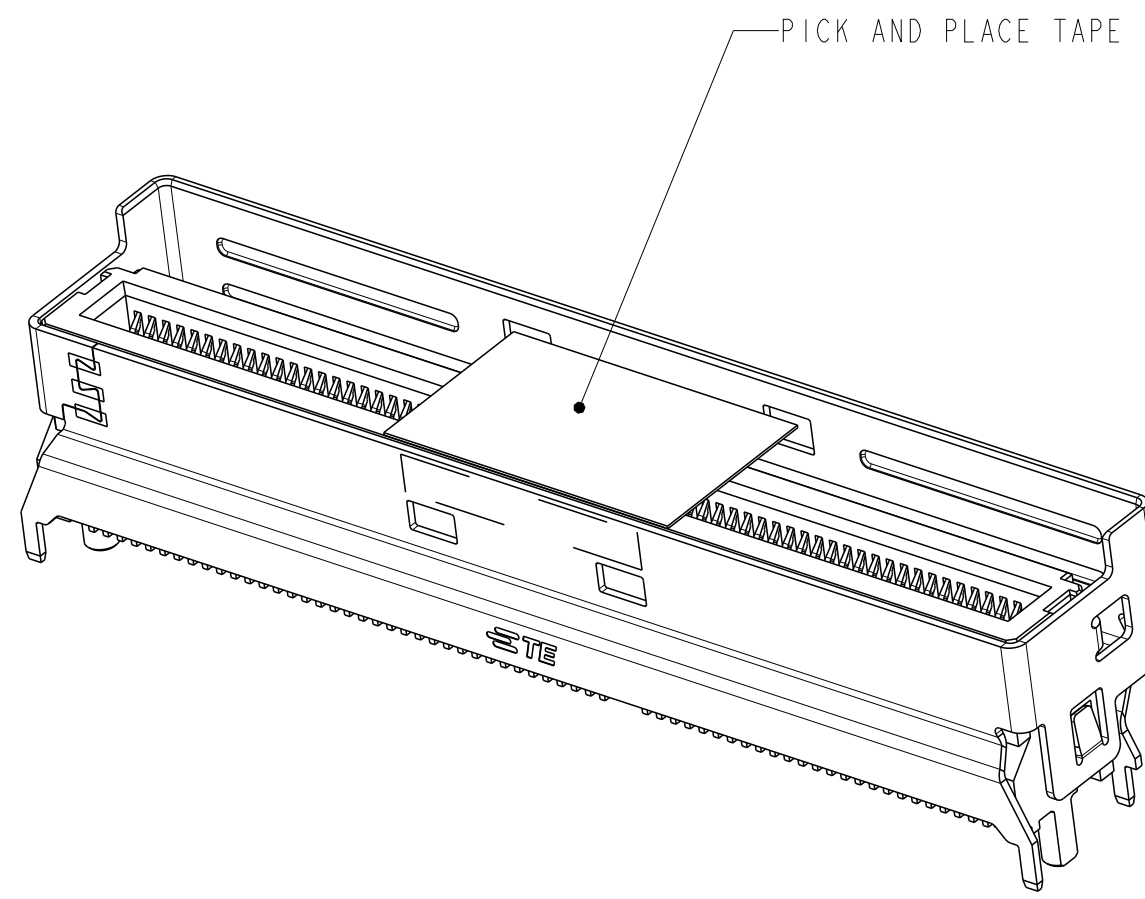

W/ PICK AND PLACE TAPE
SCALE 4:1

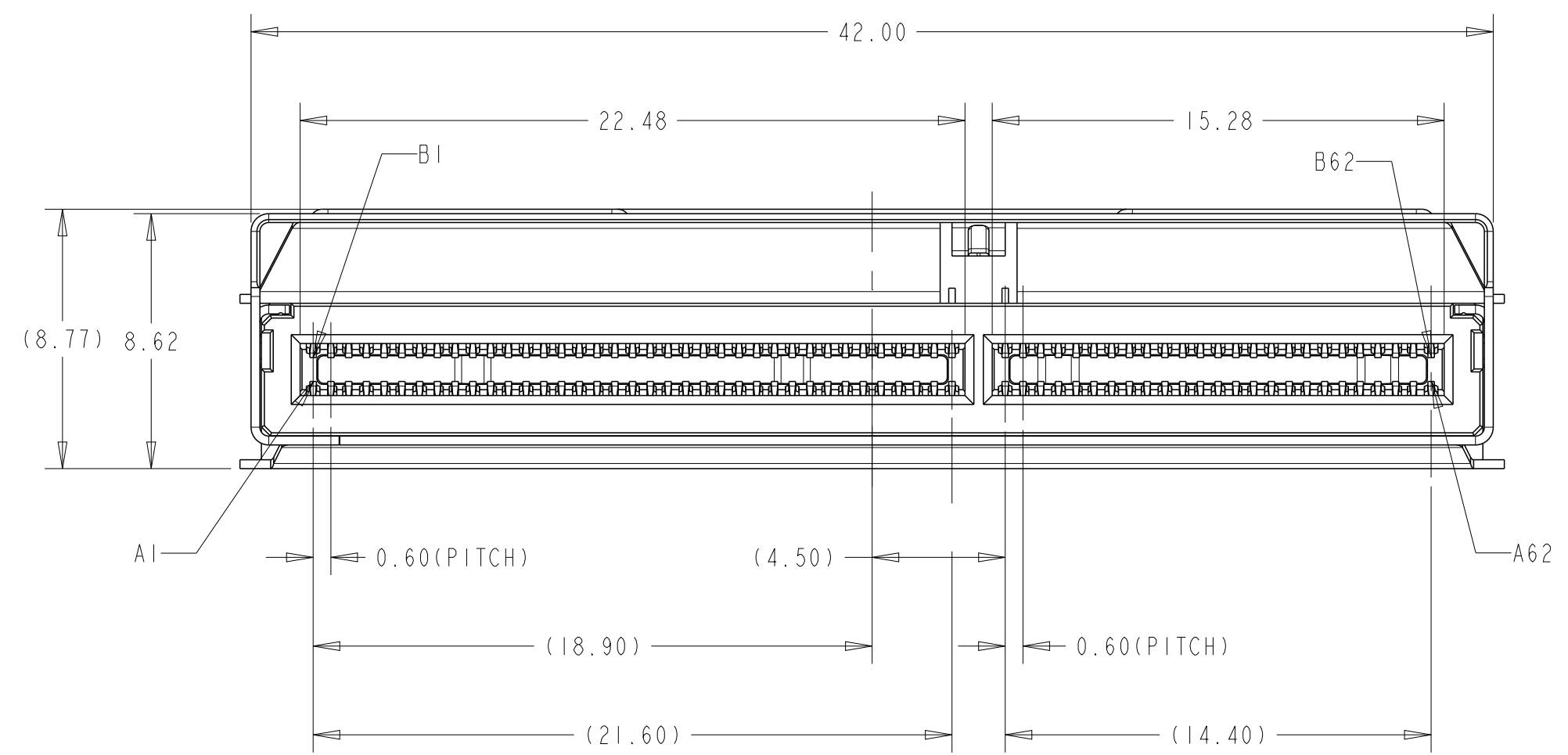
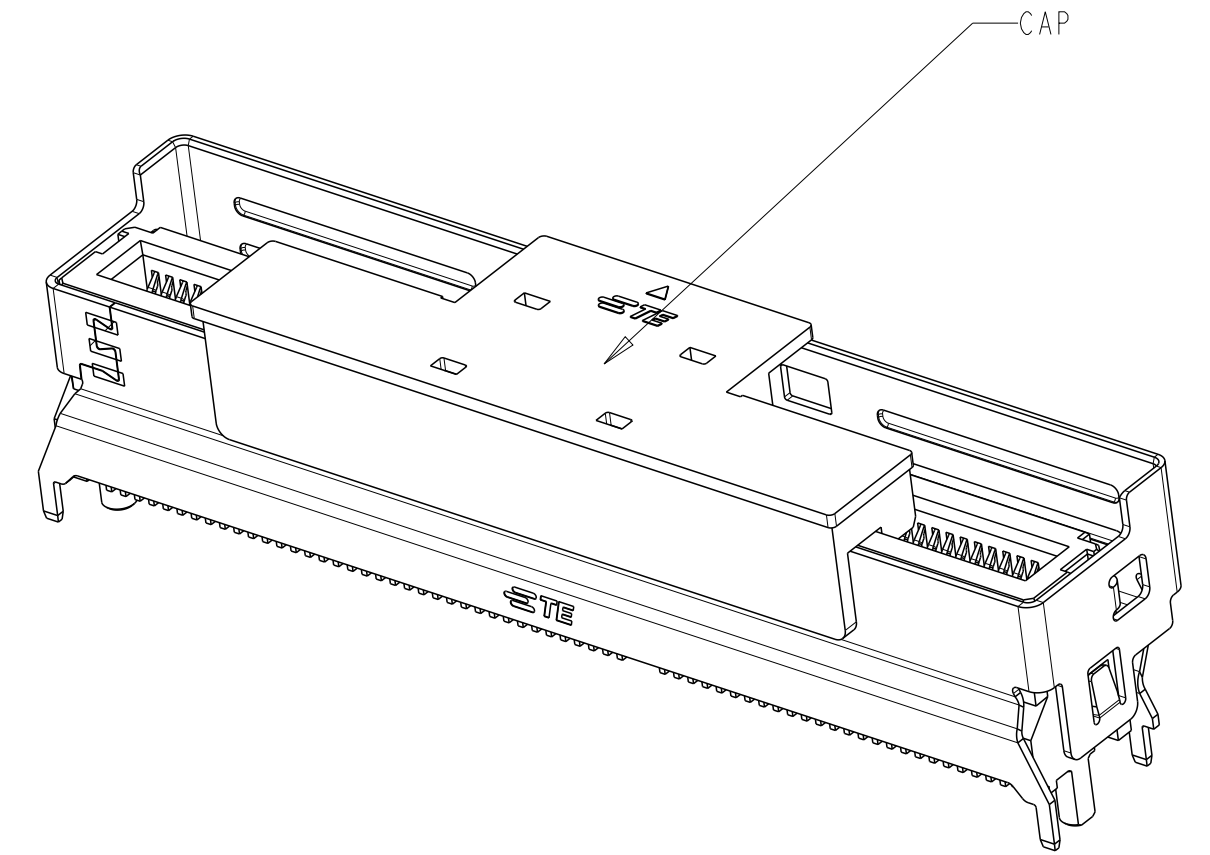

W/ CAP
SCALE 4:1

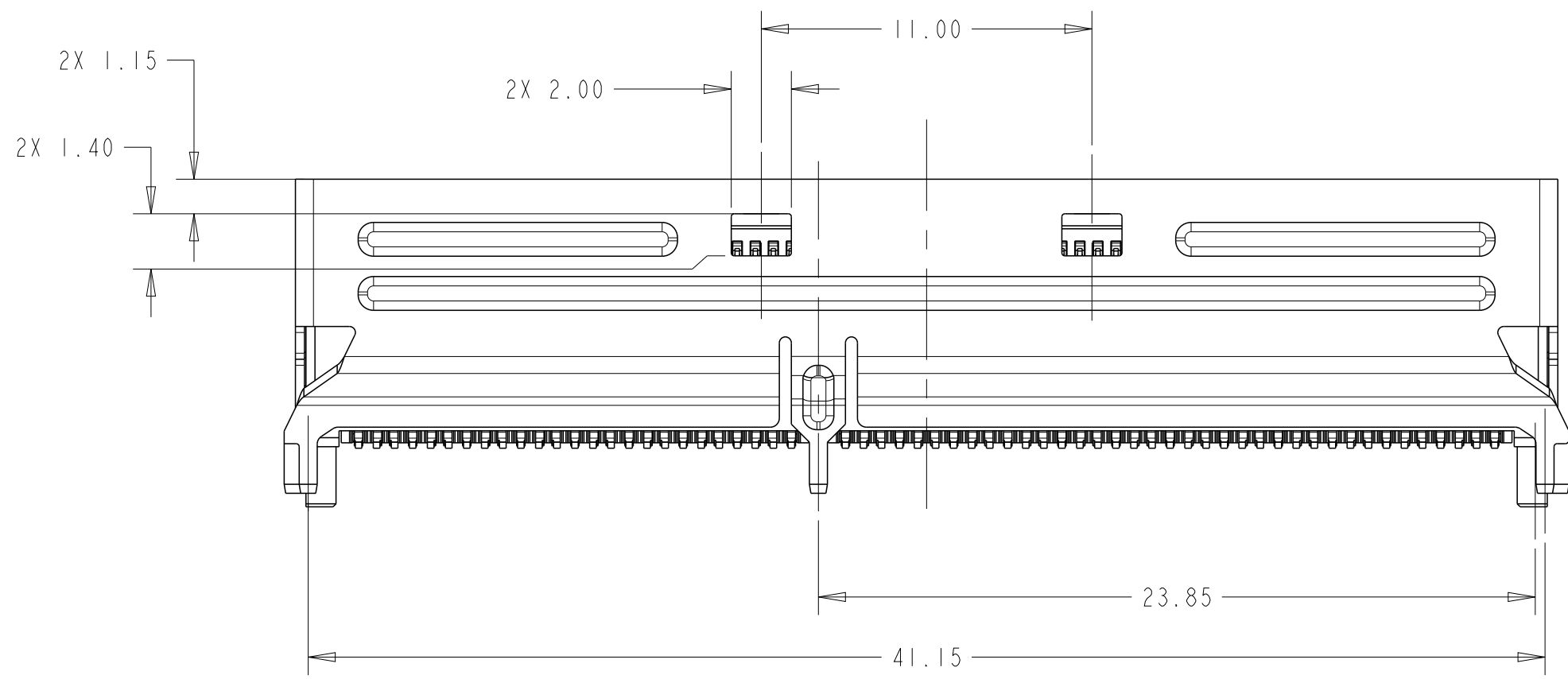
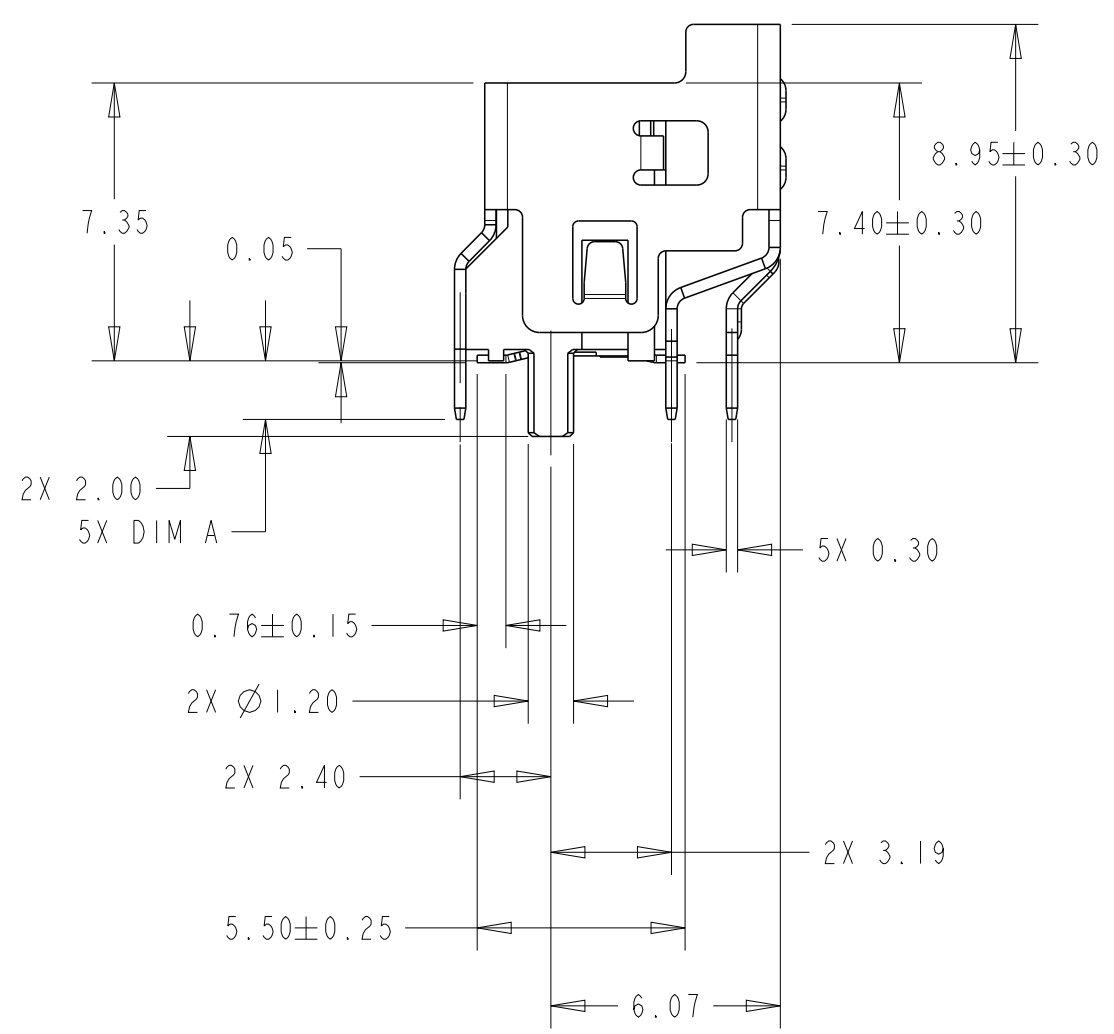
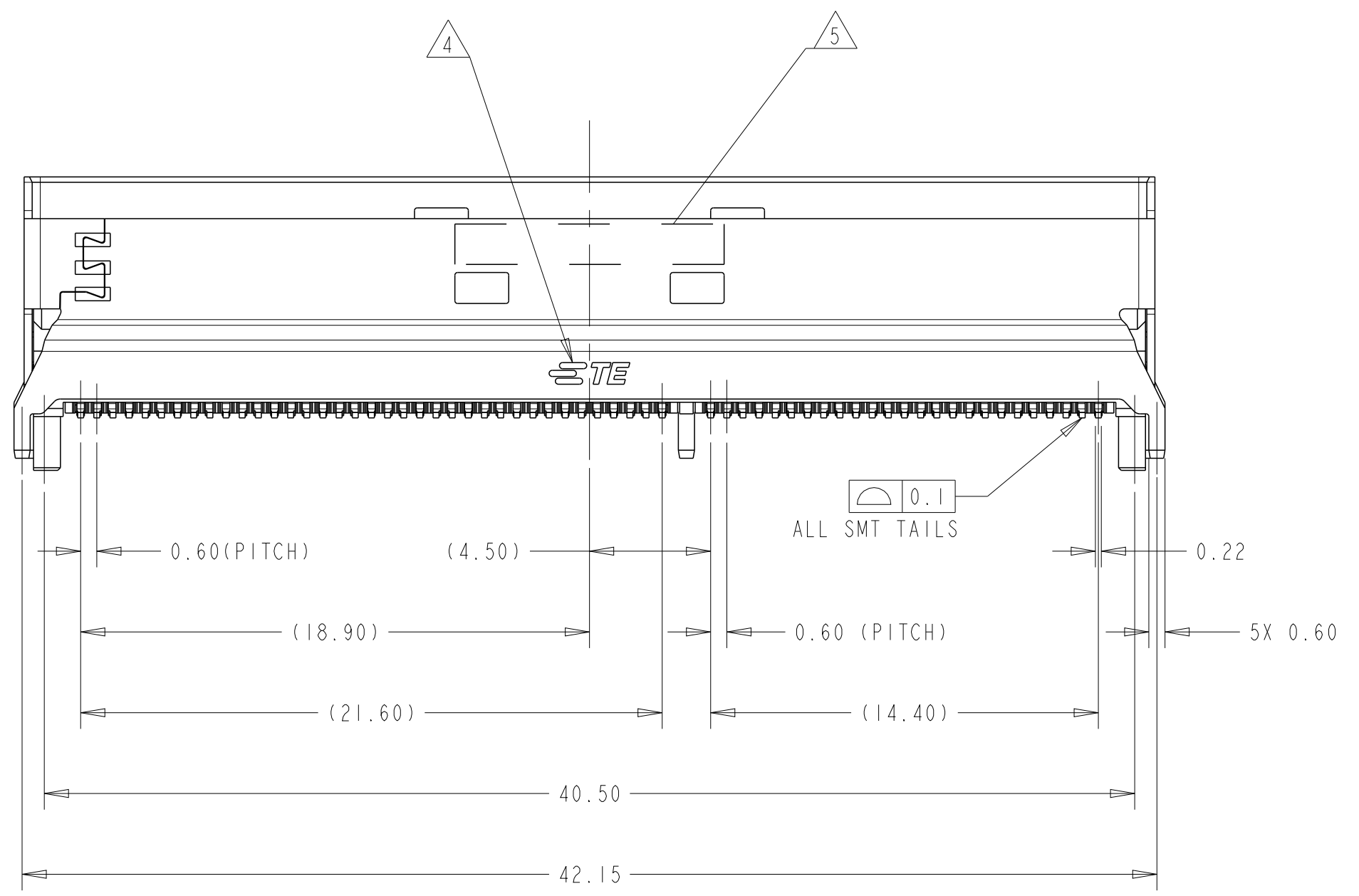

NOTES
 1. MATERIALS:
 PLASTICS: HIGH TEMPERATURE THERMOPLASTIC UL94V-0, COLOR: BLACK.
 SHELL: STAINLESS STEEL
 CONTACT: COPPER ALLOY.
 PICK AND PLACE TAPE: POLYIMIDE FILM.

2. FINISH:
 TERMINAL: CONTACT AREA: SELECTED GOLD PLATING, SEE TABLE.
 SOLDER AREA: MATTE TIN PLATING 100µ" MIN.
 UNDER PLATING: NICKEL PLATING 50µ" min OVER ALL.
 SHELL: UNDER PLATING: NICKEL PLATING 50µ" min OVERALL.

3. HALOGEN REQUIREMENT MEET CODE 2: LOW BR/CL AS DEFINED IN TEC-138-72

4. TE CONNECTIVITY LOGO MARKED IN APPROXIMATE AREA SHOWN.
 5. PART NUMBER AND DATE CODE MARKED IN APPROXIMATE AREA SHOWN.

Q'TY/CARTON	POCKET TAPE PITCH	Q'TY/REEL	CAP OPTION	CONTACT FINISH	DIM A	PART NUMBER
600	20	200	W/CAP	30u" GOLD	4.20MM	1-2360189-8
					3.00MM	1-2360189-7
					2.20MM	1-2360189-6
				15u" GOLD	1.50MM	1-2360189-5
					4.20MM	1-2360189-4
					3.00MM	1-2360189-3
			W/PICK AND PLACE TAPE	30u" GOLD	2.20MM	1-2360189-2
					1.50MM	1-2360189-1
					4.20MM	2360189-8
				15u" GOLD	3.00MM	2360189-7
					2.20MM	2360189-6
					1.50MM	2360189-5
				4.20MM	2360189-4	
				3.00MM	2360189-3	
				2.20MM	2360189-2	
				1.50MM	2360189-1	

THIS DRAWING IS A CONTROLLED DOCUMENT. DWN: LEO LI 05-AUG-2019
 CHK: DAVID ZHANG 05-AUG-2019
 APVD: DAVID ZHANG 05-AUG-2019

TE Connectivity

NAME: MINI COOL EDGE IO INTEGRATED CONNECTOR, 0.6PITCH, VERTICAL STANDARD, 124P, SMT TYPE, 920HM

SIZE: 114-60030 CAGE CODE: 00779 DRAWING NO: 2360189 RESTRICTED TO: A

CUSTOMER DRAWING SCALE: 5:1 SHEET 1 OF 5 REV A

REVISIONS				
P	LTN	DESCRIPTION	DATE	APVD
-	-	SEE SHEET 1	-	-

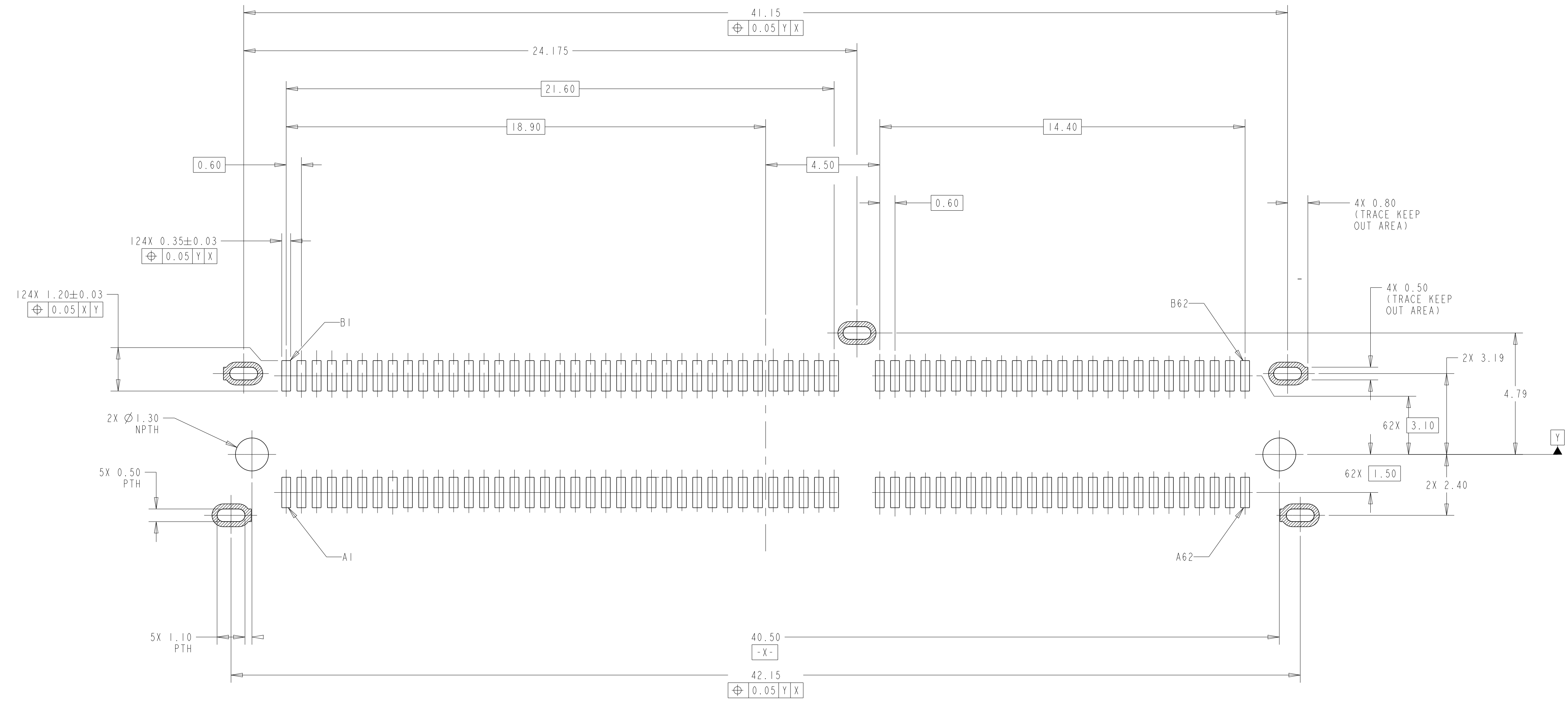

RECOMMENDED PCB LAYOUT
 (GENERAL TOLERANCES: ±0.05)
 SCALE 10:1

THIS DRAWING IS A CONTROLLED DOCUMENT.		OWN: LEO LI 05-AUG-2019	TE Connectivity
DIMENSIONS:		CHK: DAVID ZHANG 05-AUG-2019	
mm	TOLERANCES UNLESS OTHERWISE SPECIFIED:	APVD: DAVID ZHANG 05-AUG-2019	NAME: MINI COOL EDGE 10 INTEGRATED CONNECTOR, 0.6PITCH, VERTICAL STANDARD, 124P, SMT TYPE, 920HM SIZE: CAGE CODE DRAWING NO. RESTRICTED TO A 00779 C=2360189
	0 PLC ±	PRODUCT SPEC: 108-60133	
	1 PLC ±0.30	APPLICATION SPEC: 114-60030	
	2 PLC ±0.20	WEIGHT: -	
	3 PLC ±0.10	MATERIAL: -	CUSTOMER DRAWING
	4 PLC ±	FINISH: -	SCALE 5:1 SHEET 2 OF 5 REV A
	ANGLES ±°		

REVISIONS				
P	LTN	DESCRIPTION	DATE	APVD
-	-	SEE SHEET 1	-	-

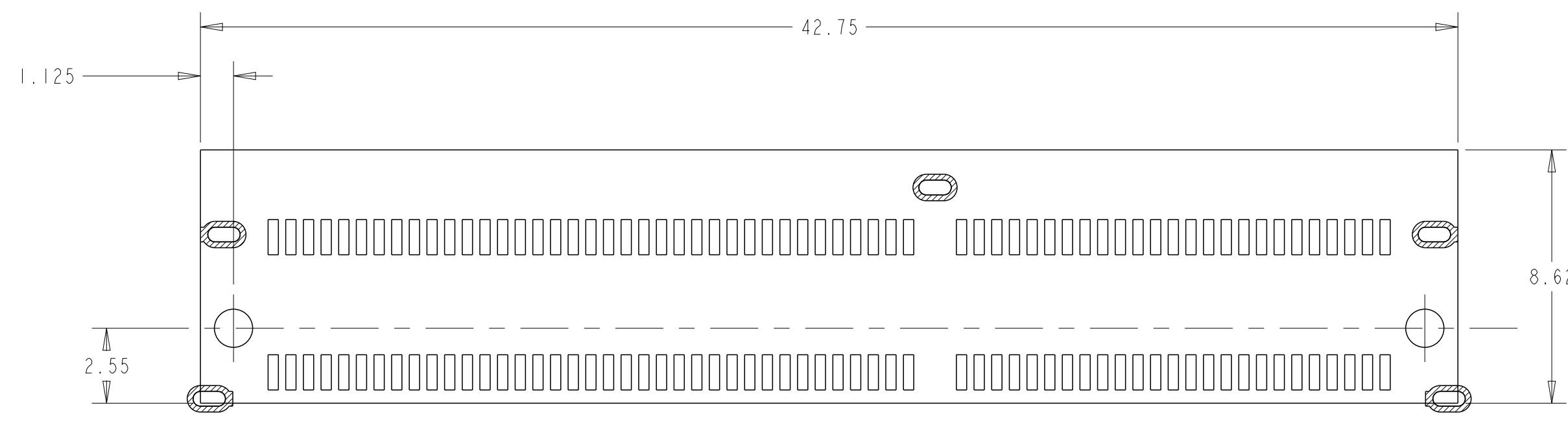

COMPONENTS KEEP OUT AREA
LIMITATION HEIGHT: 0mm
SCALE 6:1

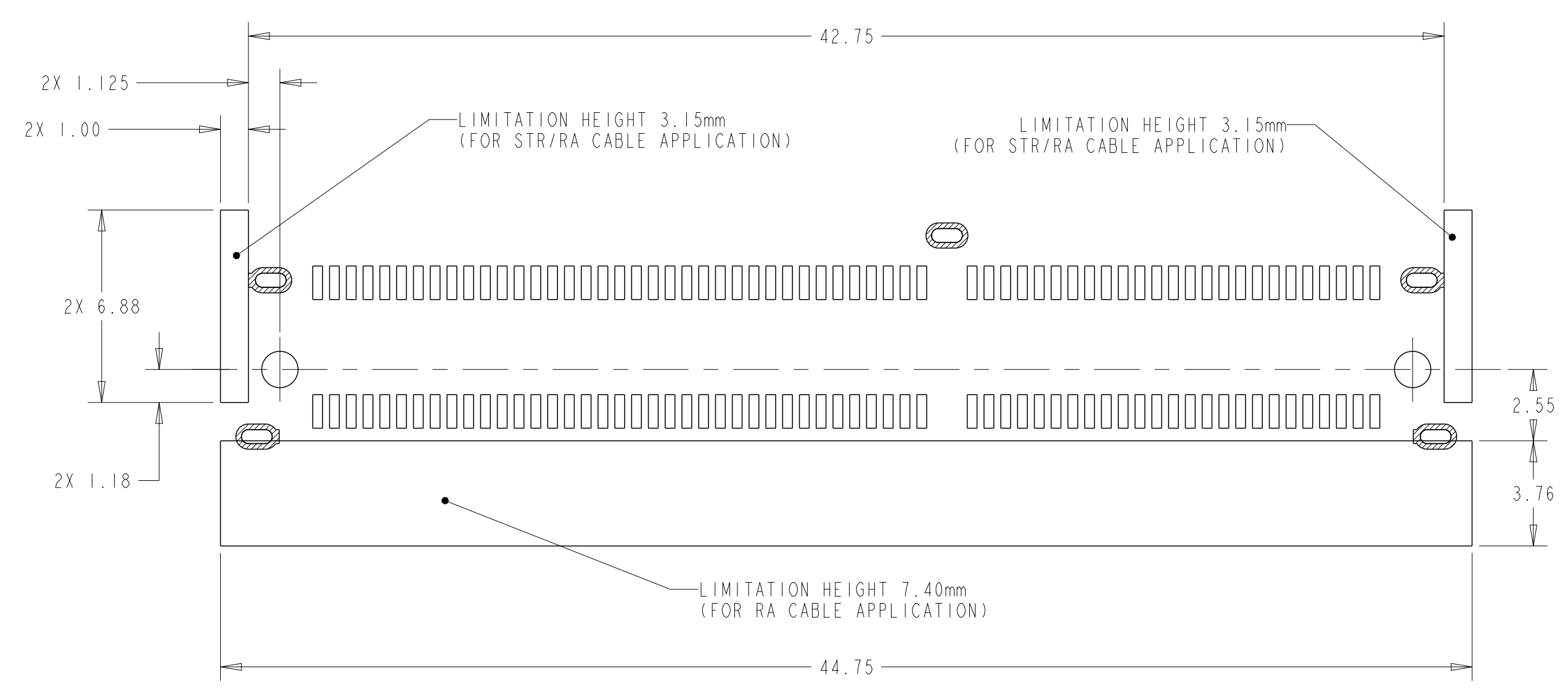

COMPONENTS KEEP OUT AREA
SCALE 6:1

THIS DRAWING IS A CONTROLLED DOCUMENT.		OWN: LEO LI 05-AUG-2019	
		CHK: DAVID ZHANG 05-AUG-2019	
DIMENSIONS:		APVD: DAVID ZHANG 05-AUG-2019	NAME: MINI COOL EDGE 10 INTEGRATED CONNECTOR, 0.6PITCH, VERTICAL STANDARD, 124P, SMT TYPE, 920HM
TOLERANCES UNLESS OTHERWISE SPECIFIED: 0 PLC ± 1 PLC ±0.30 2 PLC ±0.20 3 PLC ±0.10 4 PLC ± ANGLES ±° FINISH ±2°		PRODUCT SPEC: 108-60133 APPLICATION SPEC: 114-60030 WEIGHT: - CUSTOMER DRAWING	
MATERIAL: - FINISH: -		SIZE: A 00779 CAGE CODE: C=2360189 SCALE: 5:1 SHEET: 3 OF 5 REV: A	RESTRICTED TO

REVISIONS				
P	LTN	DESCRIPTION	DATE	APVD
-	-	SEE SHEET 1	-	-

RECOMMENDED AIC MATING CARD DIMENSIONS

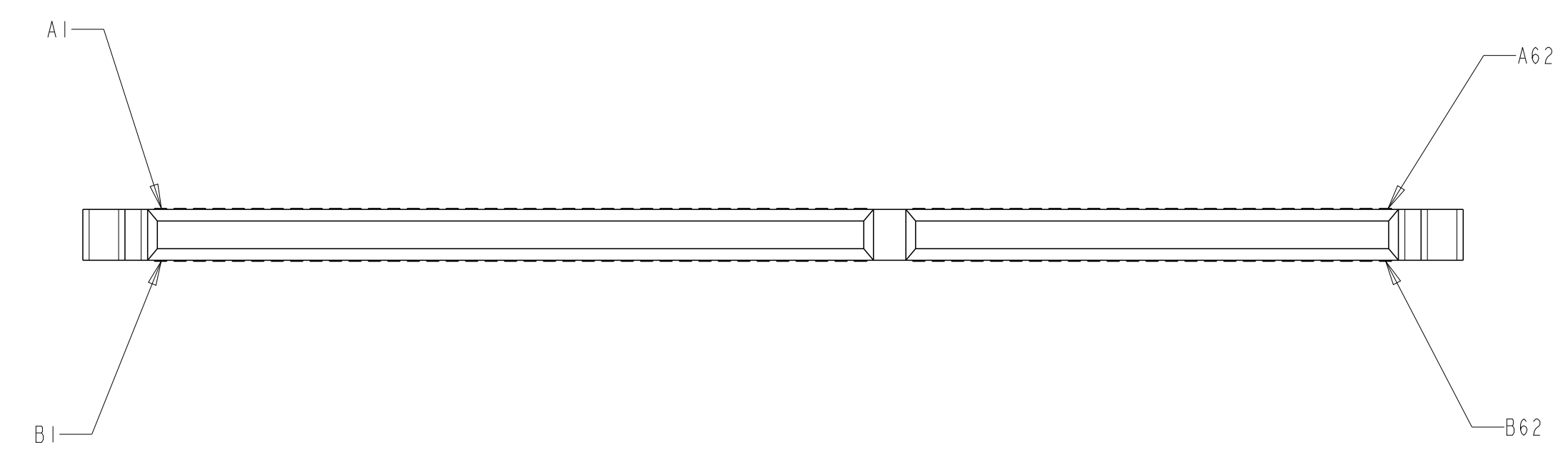
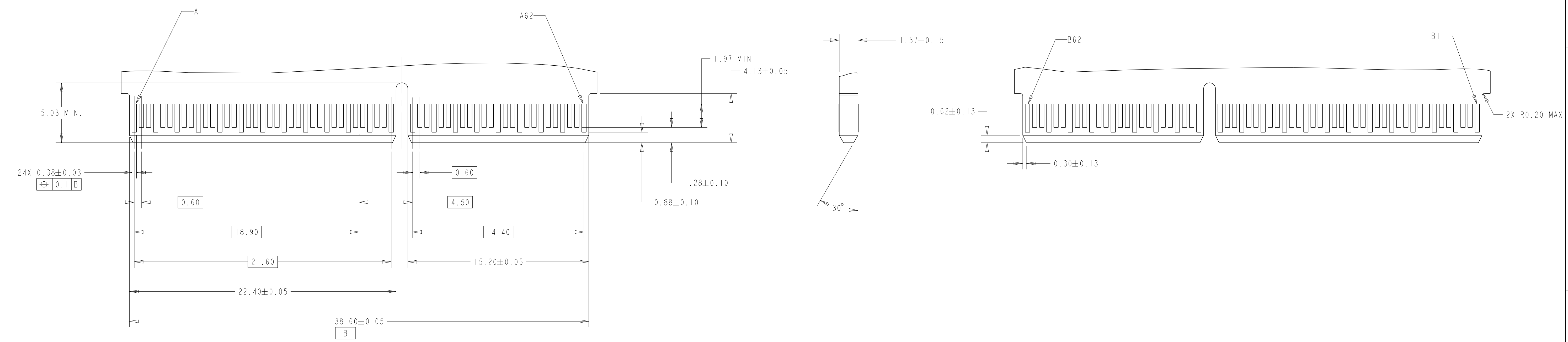

THIS DRAWING IS A CONTROLLED DOCUMENT.		OWN: LEO LI 05-AUG-2019	TE Connectivity
DIMENSIONS: mm		CHK: DAVID ZHANG 05-AUG-2019	
TOLERANCES UNLESS OTHERWISE SPECIFIED: 0 PLC ± 1 PLC ±0.30 2 PLC ±0.20 3 PLC ±0.10 4 PLC ± ANGLES ±2° FINISH		APVD: DAVID ZHANG 05-AUG-2019	NAME: MINI COOL EDGE 10 INTEGRATED CONNECTOR, 0.6PITCH, VERTICAL STANDARD, 124P, SMT TYPE, 920HM
MATERIAL: -		PRODUCT SPEC: 108-60133	SIZE: A
-		APPLICATION SPEC: 114-60030	CAGE CODE: 00779
-		WEIGHT: -	DRAWING NO: C=2360189
CUSTOMER DRAWING		SCALE: 5:1	SHEET 4 OF 5 REV A

REVISIONS				
P	LTN	DESCRIPTION	DATE	APVD
-		SEE SHEET 1	-	-

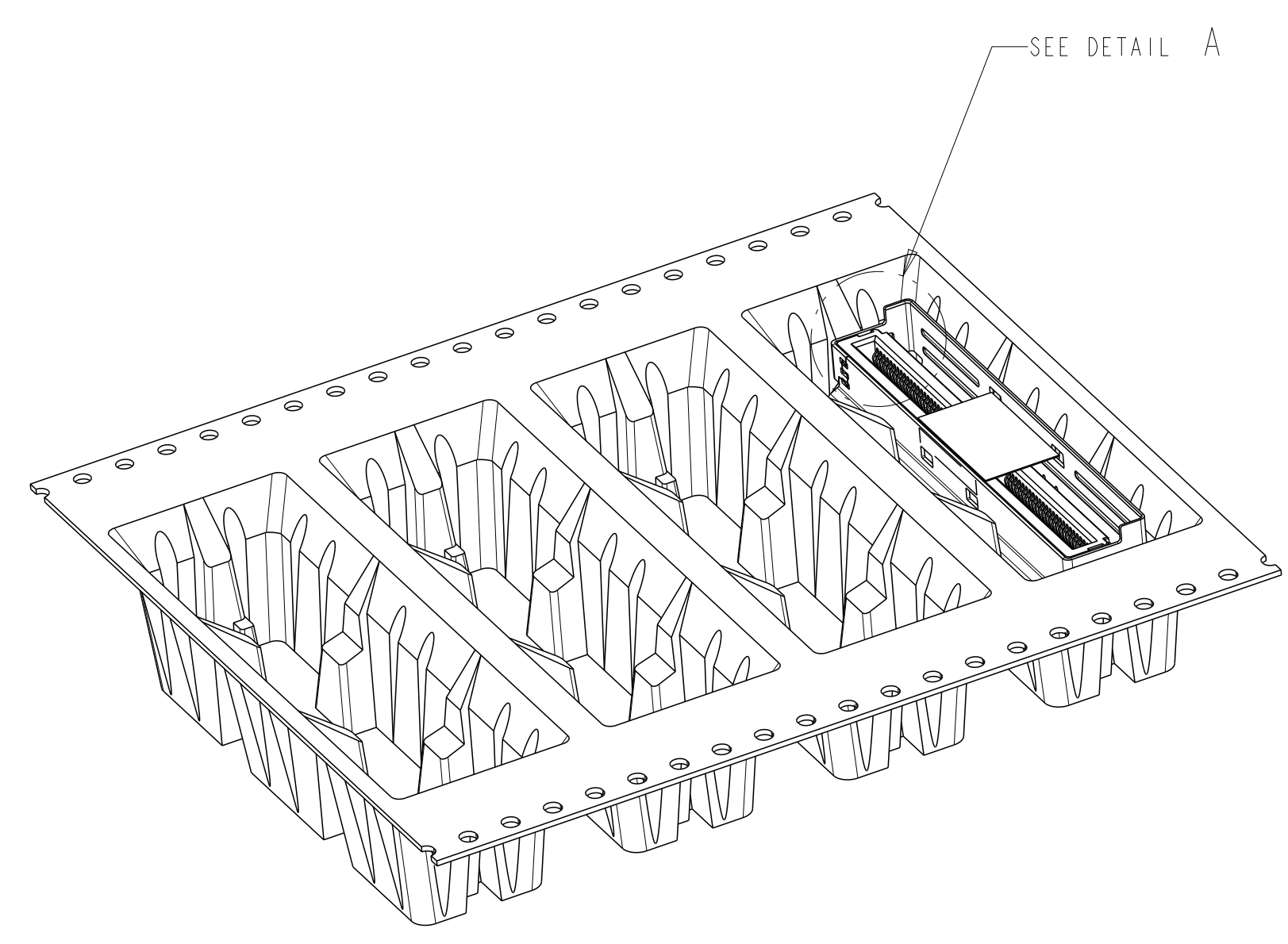
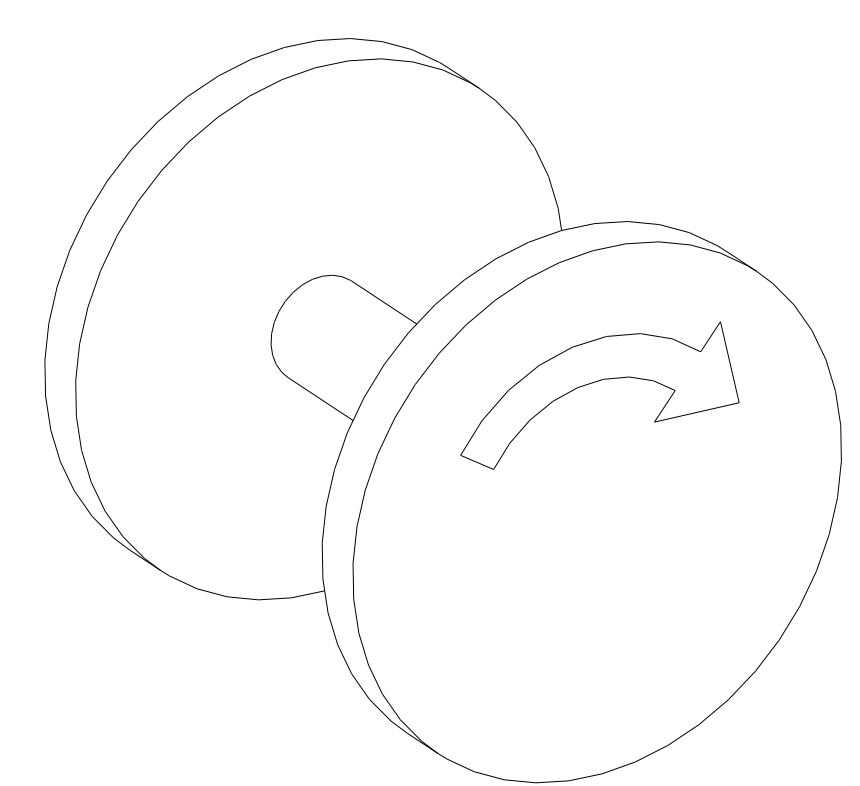
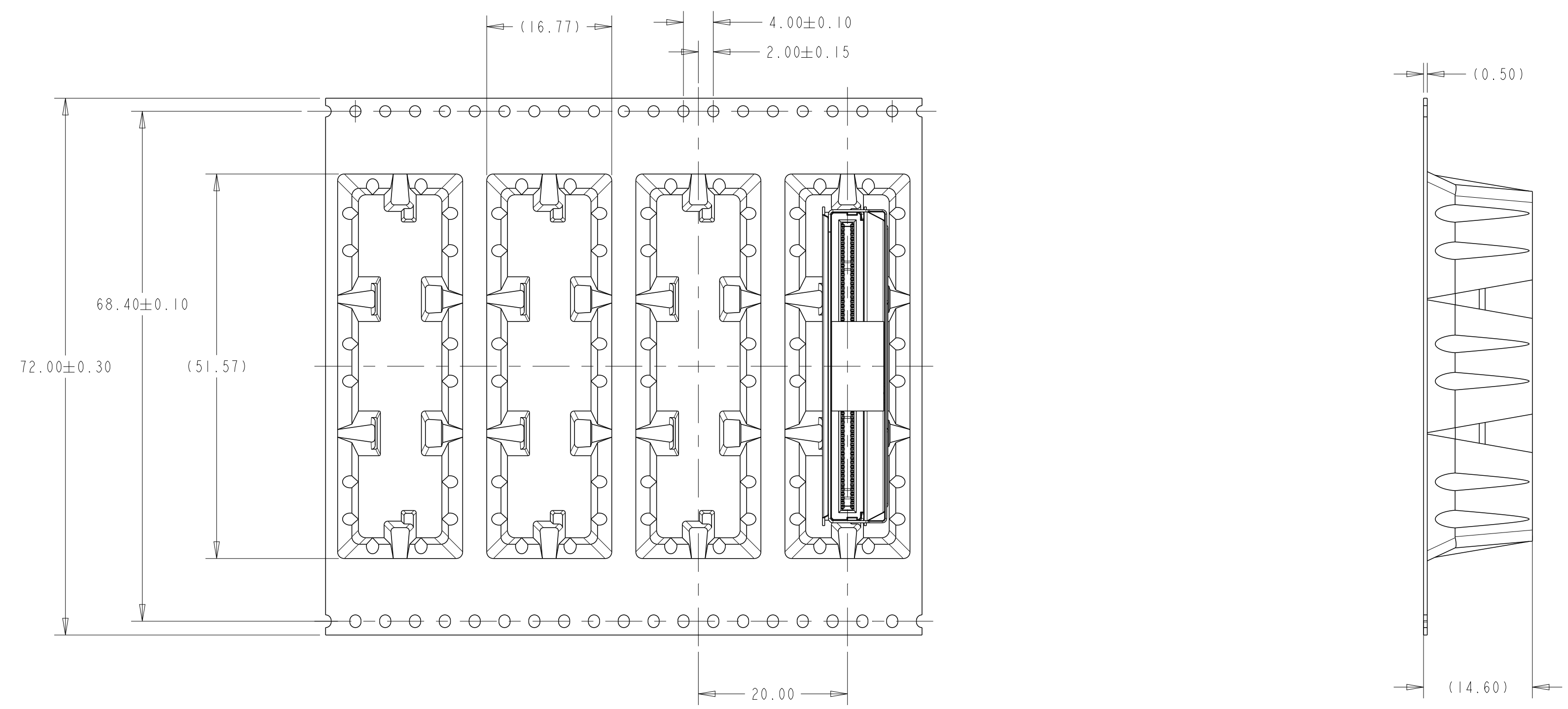
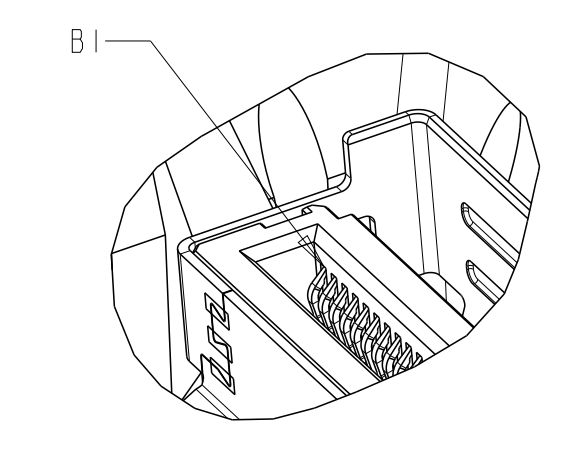

FIGURE 1
DIRECTION OFF TOP OF REEL
FOR USER UNREELING
SHOWN AS -1 THRU -8
SCALE 2:1



DETAIL A
SCALE 5:1

THIS DRAWING IS A CONTROLLED DOCUMENT.		OWN: LEO LI 05-AUG-2019	
DIMENSIONS:		CHK: DAVID ZHANG 05-AUG-2019	
mm	0 PLC ±	APVD: DAVID ZHANG 05-AUG-2019	NAME: MINI COOL EDGE 10 INTEGRATED CONNECTOR, 0.6PITCH, VERTICAL STANDARD, 124P, SMT TYPE, 920HM
	1 PLC ±0.30	PRODUCT SPEC: 108-60133	
	2 PLC ±0.20	APPLICATION SPEC: 114-60030	SIZE: A
	3 PLC ±0.10	WEIGHT: -	CAGE CODE: 00779
	4 PLC ±	CUSTOMER DRAWING	DRAWING NO: 2360189
	ANGLES ±°	SCALE: 5:1	SHEET: 5 OF 5
	FINISH ±2°		REV: A