

Features

HIGH CURRENT CARRY AND HIGH VOLTAGE

Inert gas filled arc chamber suitable for high voltage switching

COMPACT STRUCTURE, LOW NOISE

Small, low-profile design with low noise while carrying or switching loads

SAFE FOR EXPLOSIVE ENVIRONMENTS

No arc leakage due to a hermetically sealed design

HIGH RELIABILITY DESIGN

Hermetic sealing creates a stable environment for high voltage switching

NO SPECIFIC MOUNTING ARRANGEMENT

Mountable in any orientation without reduction of performance

VARIOUS APPLICATIONS

Battery disconnect, EV charging, energy storage systems, photovoltaics, power control, circuit protection and much more

Sealing Type: Ceramic

- ✓ Bottom mount/side mount options available
- ✓ Bi-directional



Certification Information

1. Meet RoHS (2011/65/EU)
2. CE certified

Nomenclature

AEVE300

B

-

Series code:

“AEVE300” = AEVE300

Coil Voltage Code:

“B” = 12VDC

“C” = 24VDC

Options (applied in this order):

Blank = Std. Options (Bottom Mount, Non-Polarized Terminals)

“S” = Side Mount Version

MAIN CONTACT

Contact Arrangement	1 Form X (SPST- NO)	
Rated Operating Voltage	750 VDC	
Rated current	300A	
Max. Short Circuit Current	8000A (5ms)	
Short Term Current	600A (2 min)	
Dielectric Withstanding Voltage (initial)	Between Open Contacts	3,000VDC, 1mA, 1min
	Between Contacts to Coil	2,500VAC, 1mA, 1min
Insulation Resistance (initial)	Terminal to Terminal	Min. 1000 MΩ@1000VDC (initial) Min 50MΩ@500VDC (After durability test)
	Terminals to Coil	
Contact Resistance (initial)	< 0.4 mΩ	
Limit Breaking	2,000A @ 500VDC, 1 Cycle	

OPERATE / RELEASE TIME

Operate Time (includes bounce)	30ms, Max. @20°C
Release Time	10ms, Max @20°C

ENVIRONMENTAL DATA

Shock	Functional	196m/s ² Sine half-wave pulse
	Destructive	490m/s ² Sine half-wave pulse
Operating Temperature	-40 to +85°C	
Humidity	5% to 85%RH	
Weight	0.88Lb (0.40kg)	

EXPECTED LIFE

Electrical Life (make only) 140A @20VDC	75,000 Cycles
Electrical Life (break only) 300A @450VDC	1000 Cycles
Mechanical Life	200,000 Cycles

COIL DATA

Nominal Voltage	12VDC	24VDC
Max. Pick-up Voltage (20°C)	9VDC	18VDC
Min. Drop-out Voltage (20°C)	0.5VDC	1VDC
Coil Power 20°C at Nominal Voltage	6W	6W
Rated Coil Resistance±10% (20°C)	24 Ω	96 Ω

Electrical Life

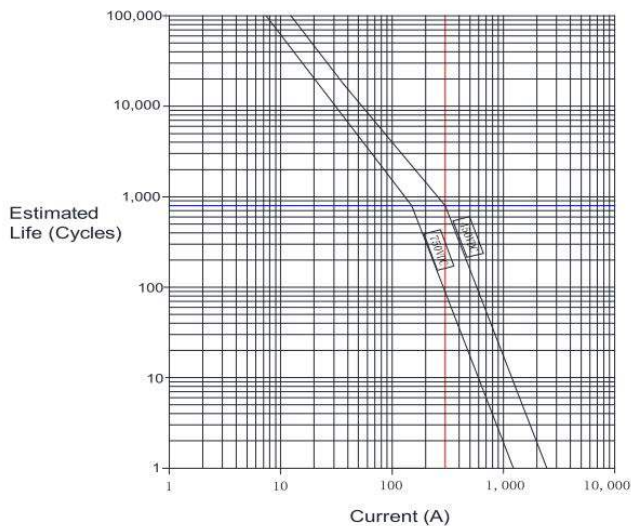

Current Carry Curve

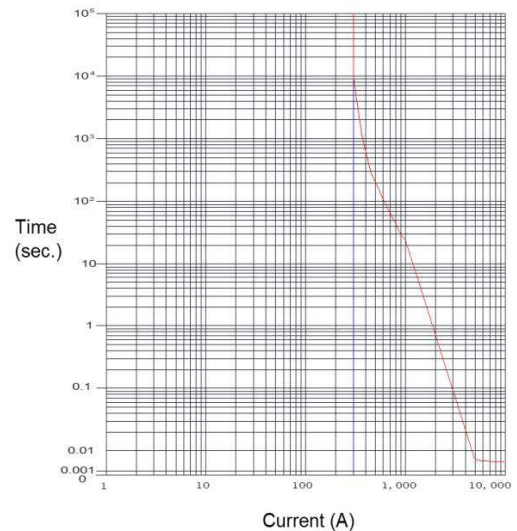

Outline Dimensions : inches (mm)
Bottom Mount

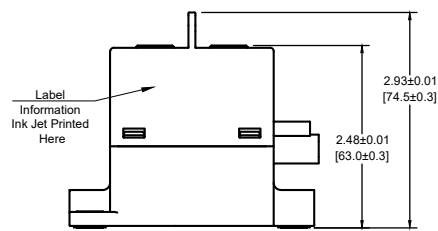
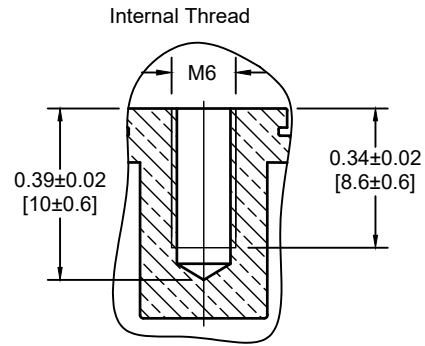
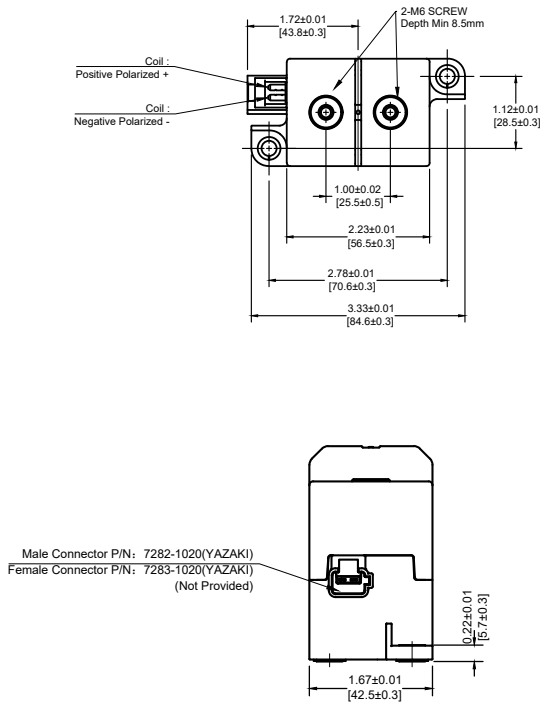

Side Mount

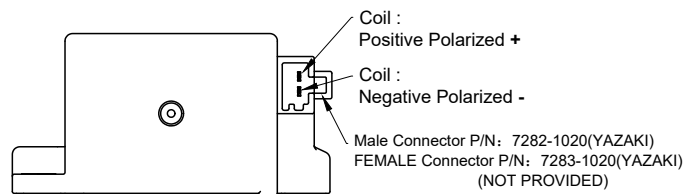
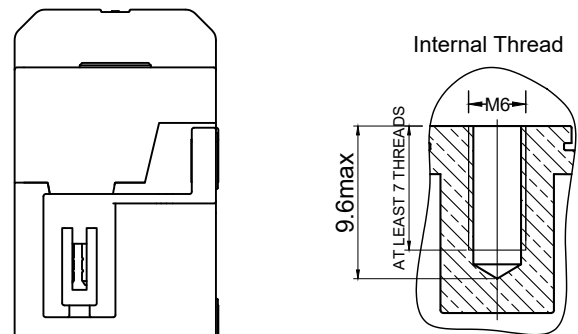
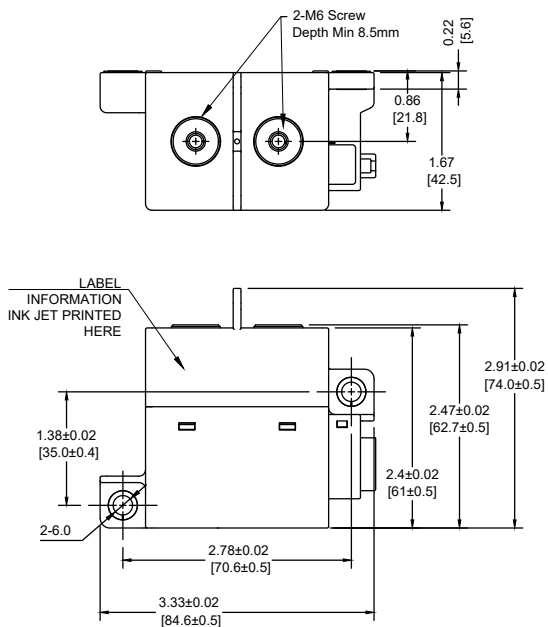

Application Notes

1. To prevent loosening, split washers should be used whenever the contactor is installed. All terminals or conductors must be in direct contact with the contactor's main terminals. Please control the tightening torque of each part within the specified range in the table below. If the torque exceeds the recommended range, it may cause damage to the sealed cavity and thread damage.
 - Static contact torque: 53.1 lb. in - 70.8 lb. in (6.0-8.0 N.m)
 - Installation torque: 26.5 lb. in - 35.4 lb. in (3.0-4.0 N.m)
2. Products with polarity marked on the load end must be used correctly according to the product label. When the load connection polarity is reversed, the electrical characteristics in this data sheet cannot be guaranteed.
3. It is necessary to design a surge absorbing circuit to absorb the reverse electromotive force of the contactor coil. Use of diodes should be avoided. Diodes connected in parallel with coils will greatly prolong the release time of contactors, which may reduce the service life of these products.
4. Avoid installing the contactor in a strong magnetic field environment (near transformers or magnets) and avoid placing the contactor near objects with heat radiation.
5. When continuous current is applied to the contacts of the relay, and the coil is turned on immediately after the power is cut off. At this time, as the temperature of the coil increases, the resistance of the coil will also increase, which will increase the pull-in voltage of the product, which may result in exceeding the rated pull-in voltage. In this case, the following measures should be taken to reduce the load current; limit the continuous power-on time or use a coil voltage higher than the rated pull-in voltage.
6. When the voltage applied to the coil exceeds the maximum allowable applied voltage, the coil temperature may rise and lead to coil damage and interlayer short circuit.
7. The rated values in the contact parameters are values for a resistive load. When using an inductive load with $L/R > 1\text{ms}$, please connect a surge current protection device to the inductive load in parallel. If no measures are taken, the electrical life may be reduced, and the continuity may be poor. Please consider sufficient margin space in the design.
8. Coil drive power must be greater than coil power or it will reduce performance capability.
9. Please do not allow debris and oil to adhere to the main terminals; Make sure that the main terminals are in reliable contact with the load conductor, otherwise the temperature rise of the terminal / conductor connection may be too high due to the excessive contact resistance.
10. The load conductor must have the corresponding current load capacity and heat dissipation capacity (it is recommended to use a copper bar with min 100mm²), to prevent overheating and affecting the life of the contactor.
11. It is impossible to determine all the performance parameters of contactors in each specific application, therefore, customers should choose the products matching them according to their own conditions of use. If in doubt, contact Altran. The customer will be responsible for validating that the products meet their application.
12. Do not use if dropped.
13. Altran reserves the right to make changes as needed. Customers should reconfirm the contents of the specification or ask for us to supply a new specification if necessary.