



RF/Microwave Products Catalog

RF Filters, Couplers, Power
Dividers and Custom RF Devices

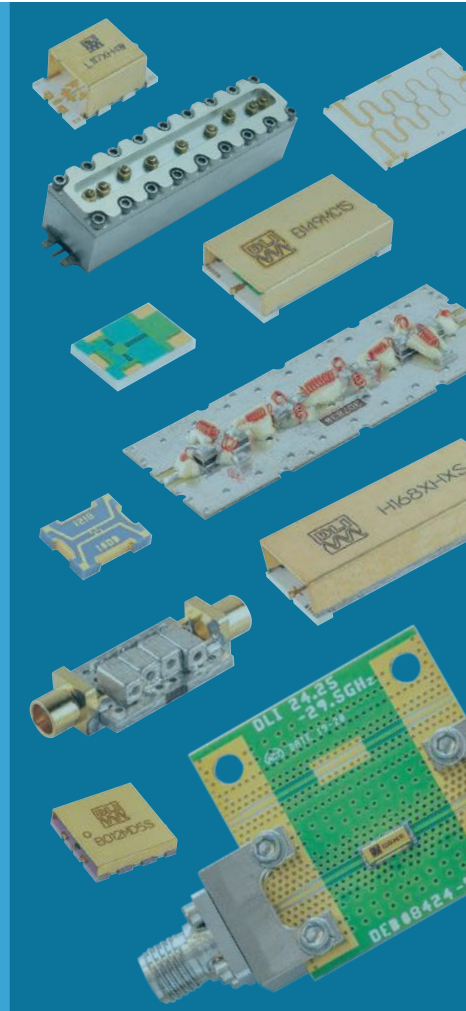
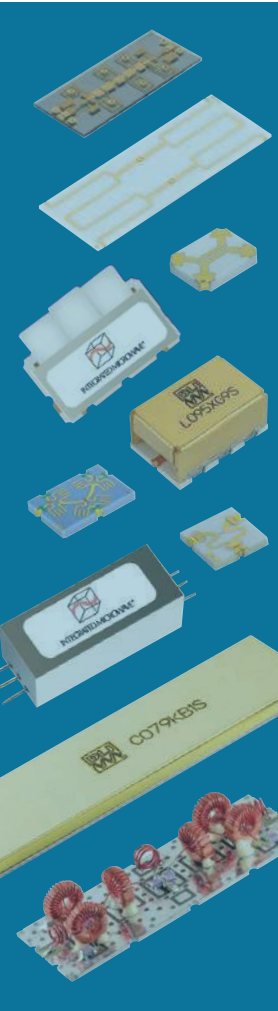

Table of Contents

Knowles Technology and Custom Design Overview

3.....	Who We Are
4-5.....	Custom Technology Portfolio
6.....	Knowles' Filter Technology
7.....	Knowles' Design Support
8-9.....	Custom Filter Technology and Specialty Filters
10.....	Diplexers and Multi-band Technology
11.....	Integrating RF Passives
12.....	Space Heritage
13.....	SatCom Devices

DLI Brand Devices and Available Product Listing

15.....	DLI Ceramic Advantages
16.....	Microstrip Filter Overview
17.....	Filter Catalog Part Number Structure
18-26.....	Bandpass Filter Selection
27.....	High and Lowpass Filter Selection
28.....	Cavity Filters
29.....	Broadband and Notch Filters
30-31.....	Power Dividers
32-33.....	Couplers
34-35.....	Integrated R-C Networks
36-37.....	Gain Equalizers
38.....	mmWave Filters
39.....	Specialty Kits

Technical Notes and Custom Configurations

40.....	User Support at your Fingertips
41.....	IMC RF Package Options
42.....	DLI Brand Device Configurations
43.....	DLI Brand Device FAQs
45.....	Quality and Environmental Policy

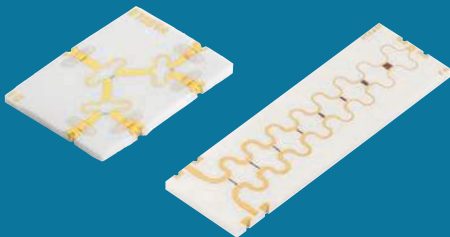

Who We Are

Knowles Precision Devices (KPD), a division of Knowles Corporation, focuses on production of a wide variety of highly engineered capacitors and microwave to mmWave components for use in critical applications in the military, medical, electric vehicle and 5G market segments. The company was formed by combining Dielectric Laboratories, Johanson Manufacturing, Novacap, Syfer and Voltronics, each well-established specialty capacitor makers with a combined history of over 200 years, into a single organization.

As a specialty components manufacturer, Knowles Precision Devices chooses to take on the complex challenges that come with high-reliability, high-temperature, high-performance, and high-frequency solutions. The Knowles Precision Devices DLI brand of technologies addresses the complex challenges of implementing high-performance RF/Microwave product across the widest range of specifications.

Microwave Product Evolution Timeline

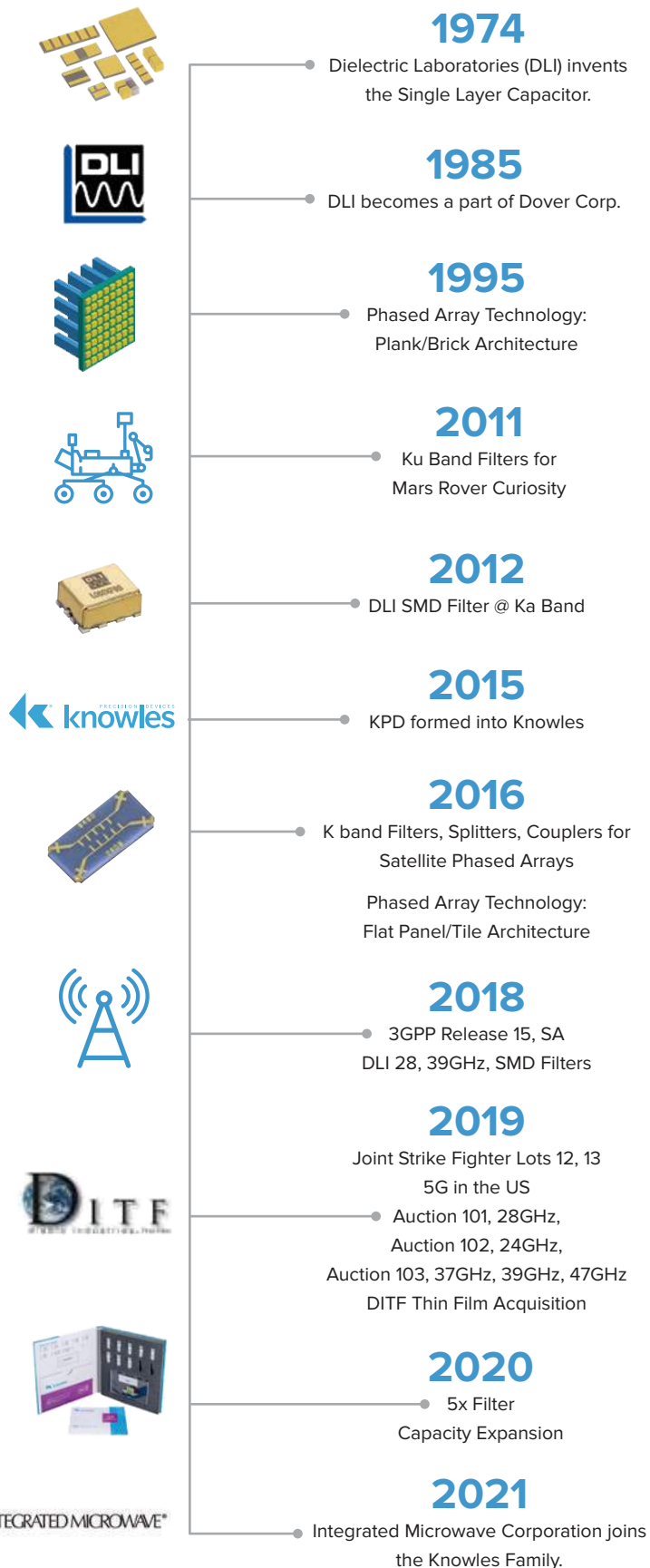

Custom is Standard for Us

What you see in this catalog is just the tip of the iceberg for the design capability with Knowles!

Collaboration Is the Key to Top Performance!

- Leverage Knowles expertise to achieve your performance goals with low cost of ownership and optimized SWAP-C
- Utilize DLI brand ceramics to achieve stable performance over wide temperature ranges
- Achieve the best manufacturing outcomes with Knowles' precision processing and testing capabilities

Knowles' Design

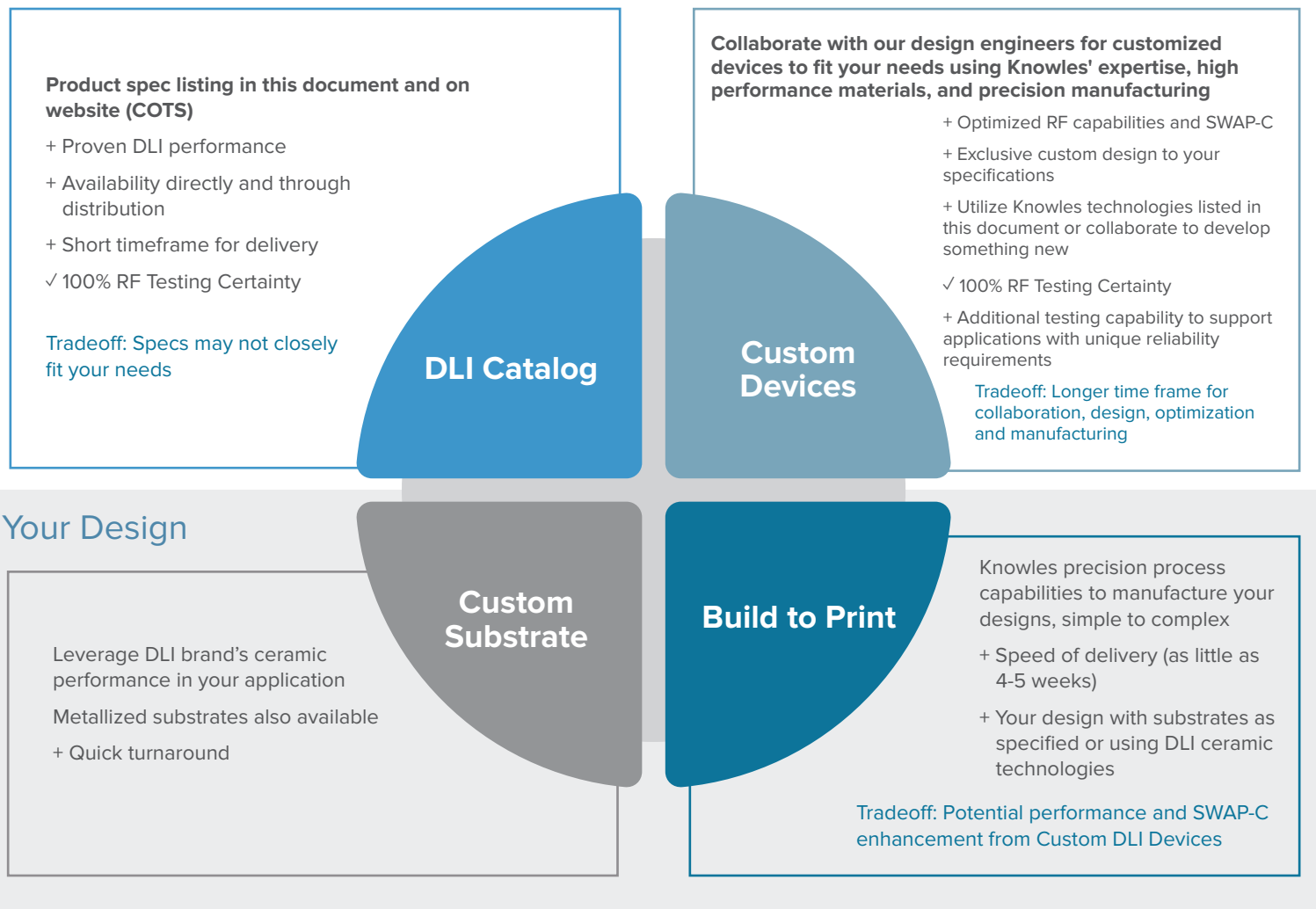

Custom Technology Portfolio

Knowles offers a wide range of devices to meet your application needs.

FILTERS	<ul style="list-style-type: none"> • Microstrip • Coaxial Ceramic • Ceramic Cavity • Cavity 	<ul style="list-style-type: none"> • Lumped Element • Waveguide • Custom 	0.1 MHz - 67+ GHz
COUPLERS	<ul style="list-style-type: none"> • Wilkinson Couplers • Resistive Couplers 	<ul style="list-style-type: none"> • Quadrature Hybrid Couplers 	0.3 - 60 GHz
DIVIDERS	<ul style="list-style-type: none"> • Wilkinson Power Dividers (or Combiners) • Resistive Power Dividers 		2 - 60 GHz
MULTIPLEXERS	<ul style="list-style-type: none"> • Diplexers • Duplexers 	<ul style="list-style-type: none"> • Triplexers 	0.1 MHz - 67 GHz
RESONATORS	<ul style="list-style-type: none"> • Ceramic resonators 	<ul style="list-style-type: none"> • Thin film resonators 	0.3 - 65 GHz
INTEGRATED PASSIVES	<ul style="list-style-type: none"> • CRC Networks 	<ul style="list-style-type: none"> • Custom Solutions 	DC - 67+ GHz

APPLICATIONS



Knowles' Filter Technology

Knowles Precision Devices' expanded portfolio brings together varied approaches to deliver the best performance to meet your requirements. Since different applications require different data rates to successfully transmit signals without introducing noise, different types of filters are necessary as bandwidth and frequency increase.

Filter Technology	Frequency Range (GHz)	Bandpass	Bandreject/Notch	Lowpass	Highpass	Custom Designs	Built to Order	Catalog (COTS) Part Numbers Available
Microstrip	0.8 - 67+	✓	✓	✓	✓	✓	✓	✓
Coaxial Ceramic	0.3 - 6	✓	✓	✓	✓	✓	✓	
Cavity	0.3 - 30	✓	✓			✓	✓	
Lumped Element	DC - 15	✓	✓	✓	✓	✓	✓	

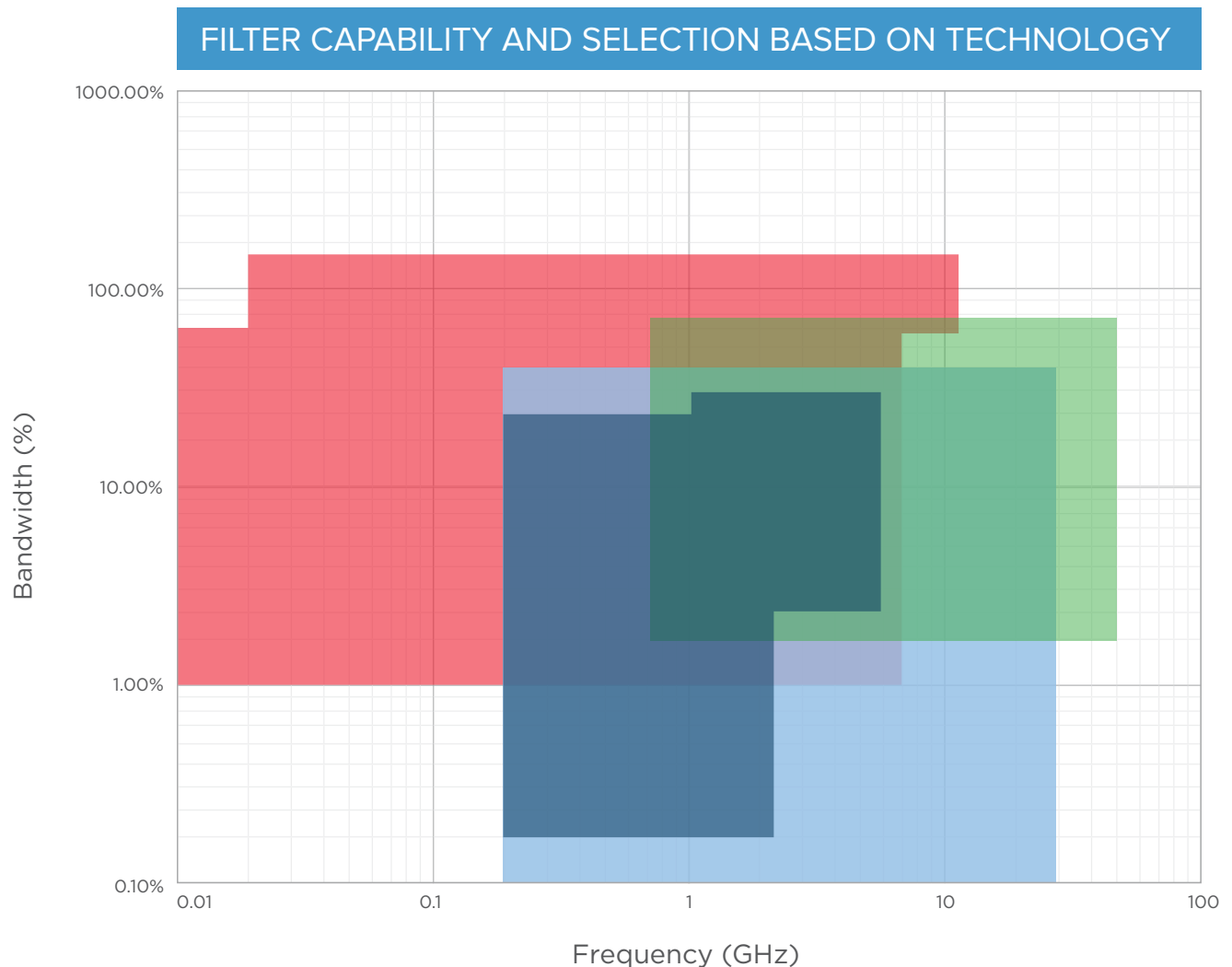

Visit www.knowlescapacitors.com/Products/Microwave-Products/Filter-Technology for COTS Part Numbers, Reference Designs and Datasheets.



Design Support from Knowles

Knowles Precision Devices provides a full range of engineering expertise and services. When the design team reviews the provided specs, we assess feasibility and which technology category best fits the requirements. These capabilities are fully utilized in providing custom filter solutions to fit your needs.

Your finished design will include custom datasheet specs, outline drawing and recommended PCB layout, reflecting the parameters of simulated performance.



ASSURING DESIGN COMPLIANCE

- Compliance with design parameters can only occur if all phases from modeling to production are monitored for strict conformance to customer requirements and design standards. Knowles Precision Devices takes pride in the close and constant attention paid to every aspect of the design process, from the acquisition of raw materials to final inspection and shipping of the finished product.
- Every component is continuously monitored for electrical and physical performance, workmanship and compliance to applicable specifications.

Reach out to our engineers for assistance with custom designs at: DLengineering@knowles.com

COMPUTER-AIDED CAPABILITIES

- Synthesis/Analysis
- Design
- Engineering
- Manufacturing
- Full MIL Standard Capability for Environmental Testing
- QA Tracking

TRANSFER FUNCTIONS

Frequency Domain

- Chebyshev
- Butterworth
- Elliptic (Cauer)
- Pseudo-Elliptic

Transitional

- Gaussian (6 dB)
- Gaussian (12 dB)

Time Domain

- Gaussian
- Bessel
- Linear Phase (.05°)
- Linear Phase (.5°)

TYPICAL CERAMIC FILTER ENVIRONMENTAL SPECIFICATIONS

- Knowles' custom devices are designed to meet performance specifications after being subjected to the physical and environmental tests of MIL-STD-202 listed below, unless otherwise noted.
- For details of electrical testing associated with DLI devices see page 43.
- Knowles also offers testing beyond what is our standard, based on the needs of an application, see page 12.

	SPEC	MIL-STD-202	METHOD CONDITION
Temperature, Operating	-20 to +70°C (Commercial) -40 to +85°C (Industrial) -55 to +125°C (Military)	-	-
Temperature, Storage	-55 to +125°C	-	-
Altitude	From Lower Earth to Deep Space	105	E
Humidity	90% RH to Full Hermetic*	106	-
Thermal Shock	-55 to +125°C	107	B
Solderability	95% Coverage	208	-
Solvent Resistance*		215	-

*Depending on device and configuration



IMC Brand Filter Technology

HIGH PERFORMANCE COAXIAL CERAMIC FILTERS

- Knowles' industry-leading ceramics capabilities together with proprietary ceramics formulations enable these filter to offer the best combination of performance and size
- Custom designs from 200MHz to 6GHz with bandwidths from 0.2% to 45%
- Coaxial ceramic filters are the ideal option for applications with high Q in the UHF and microwave frequency ranges



LUMPED ELEMENT FILTERS

- Offer small size at low frequencies not achievable by ceramic, cavity or waveguide implementations
- Knowles' advanced modeling and design can achieve virtually any filter response shape utilizing a combination of technologies (i.e. True elliptic, pseudo-elliptic and quasi-elliptic functions and lumped Gaussian, Gaussian elliptic, Bessel and Bessel elliptic and Conventional Chebyshev or Helical approaches)

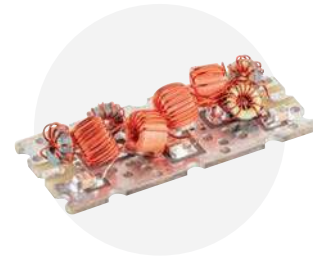

CAVITY FILTERS

- Knowles offers a full range of IMC brand cavity filters for unsurpassed performance in a wide spectrum of applications
- Combine for High Q, elliptic response, delay equalized
- Interdigital for wide band, High Q symmetrical response
- Cavity Bandpass/Band reject for unsurpassed notch depth and selectivity



Reference Page 41 for details on Packaging Options for PCB Mount, Surface Mount and Connectorized Configurations.

Visit www.knowlescapacitors.com/Products/Microwave-Products/Filter-Technology for Reference Designs and Datasheets.



IMC Brand Specialty Filters



LINEAR PHASE FILTERS

Knowles Precision Devices has the technology to model and produce filters that are capable of meeting both group delay and amplitude specifications simultaneously, without the use of separate equalizers. These filters can be designed to meet VSWR and attenuation specifications very nearly equal to more conventional Chebyshev or Butterworth designs, while maintaining a low-group delay variation over a large percentage of the passband. Insertion loss variation over the passband will closely track the group delay variation.

AMPLITUDE EQUALIZERS

With amplitude equalizers, additional circuitry can be applied to further flatten passband variation by lowering the high ranges of the band relative to the band edges.

DELAY AND PHASE EQUALIZERS

Sharp filter rejection roll-off is always accompanied by large group delay variation. When both fast roll-off and flat group delay are needed, equalizer can be used. Sometimes multiple equalizers are needed to achieve very flat group delay and phase performance.

- Send your requirements to us when you need both sharp roll-off and small group delay variation or flat phase. Delay equalizers can be implemented to almost any filter to flatten group delay and phase response by up to 20:1 ratios, at the expense of insertion loss.

ABSORPTIVE FILTERS OR OUT OF BAND RETURN LOSS FILTERS

An absorptive filter or also referred to as an out of band return loss filter can be translated as a terminated diplexer or triplexer where the out of band filter only has return loss.

NARROWBAND FILTERS FOR STUDIO TRANSMITTER LINK (STL) RECEIVERS

Knowles Precision Devices offers narrowband cavity filters for Canadian and US STL bands (photo below). Ceramic filters are also available for STL applications in Mexico, Central and South America. These filters are designed for receiver preselector use, offering outstanding signal separation. Passband loss is typically 7 dB or less, while

rejection is 60 - 100 dB. These filters allow virtually private band use in congested areas. Wideband filters cover 100% of the STL band, while narrowband versions can be less than 750 kHz wide. Narrowband filters come pretuned to your STL frequency and STL bandwidth.



BEFORE

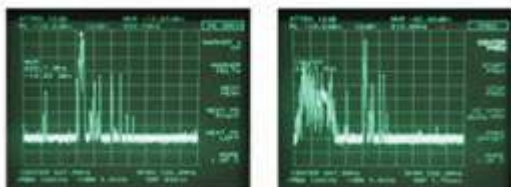

AFTER



Before: Actual example of radio congestion on top of mountain.

After: Displays the same view after the installation of STL filter.



Diplexers and Integrated Multi-band Custom Options



Knowles' expertise delivers highly efficient and frequency selective integrated multi-band solutions in a variety of configurations for the most targeted performance (up to 4 bands), including COTS PNs for Telecom Applications. This approach not only saves space but also streamlines design and placement through integration.



DUALBAND OR MULTIBAND

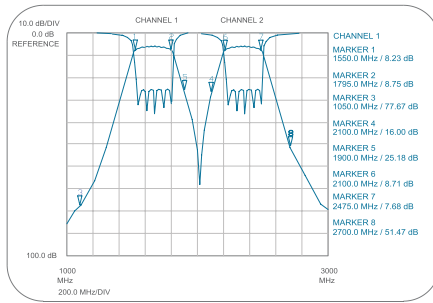
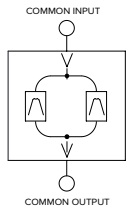

DIPLEXER, DIPLEXER OR MULTIPLEXER

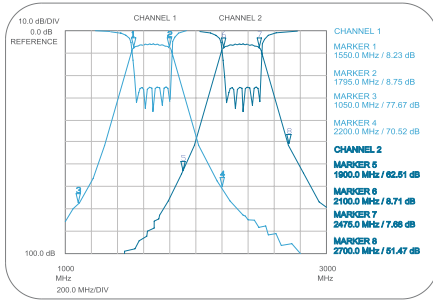
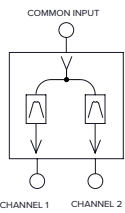

FILTERBANK, DUALBANK OR MULTIBANK

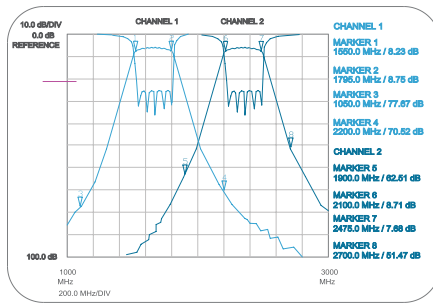
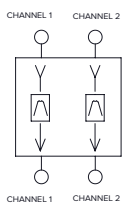

HI/LO DIPLEXER, DIPLEXER OR MULTIPLEXER

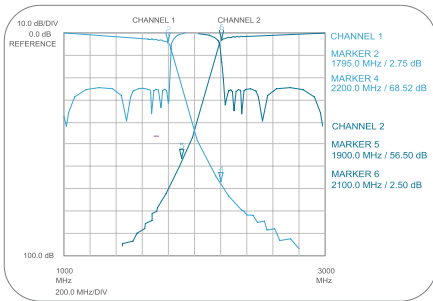
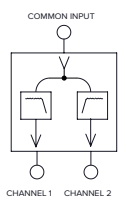

ADP09388 28 and 40GHz Diplexer (SMD) with 1 Input, 2 Outputs

	PARAMETER	FREQUENCY RANGE (GHZ)	SPEC (DB)
LOW BAND	Maximum Insertion Loss	26.5 - 29.5	4.5
	Minimum Return Loss	26.5 - 29.5	10
	Minimum Low Side Rejection	DC - 23.5	35
	Minimum High Side Rejection	32.0 - 43.0	35
HIGH BAND	Maximum Insertion Loss	37.0 - 40.0	4.5
	Minimum Return Loss	37.0 - 40.0	10
	Minimum High Side Rejection	44.0 - 55.0	25
SIZE (nominal)	L x W x H	0.335 x 0.180 x 0.070	inches
	L x W x H	8.51 x 4.57 x 1.52	mm

ADP09387 28 and 40GHz Diplexer (SMD) with 2 Inputs, 2 Outputs

	PARAMETER	FREQUENCY RANGE (GHZ)	SPEC (DB)
LOW BAND	Maximum Insertion Loss	26.5 - 29.5	4.5
	Minimum Return Loss	26.5 - 29.5	10
	Minimum Low Side Rejection	DC - 23.5	35
	Minimum High Side Rejection	32.0 - 43.0	35
HIGH BAND	Maximum Insertion Loss	37.0 - 40.0	4.5
	Minimum Return Loss	37.0 - 40.0	10
	Minimum High Side Rejection	44.0 - 55.0	25
SIZE (nominal)	L x W x H	0.275 x 0.187 x 0.060	inches
	L x W x H	6.99 x 4.75 x 1.52	mm

Knowles' Customized Designs Frequency Range: DC – 40 GHz

Available Technology:

- Microstrip
- Ceramic
- Cavity
- Lumped Element

Available Configurations:

- Surface Mount (SMD)
- Chip and Wire (Wirebond)
- PC Mount
- Connectorized
- Customized
- RoHS
- Hermetic



Integrating RF Passives on a Single Substrate

Knowles Precision Devices has done a lot of passive integration!

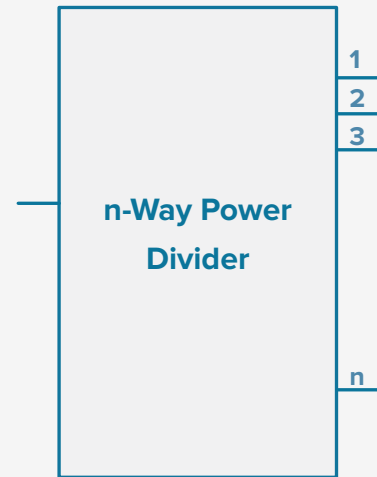
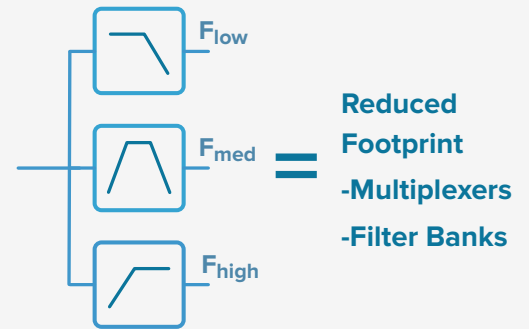
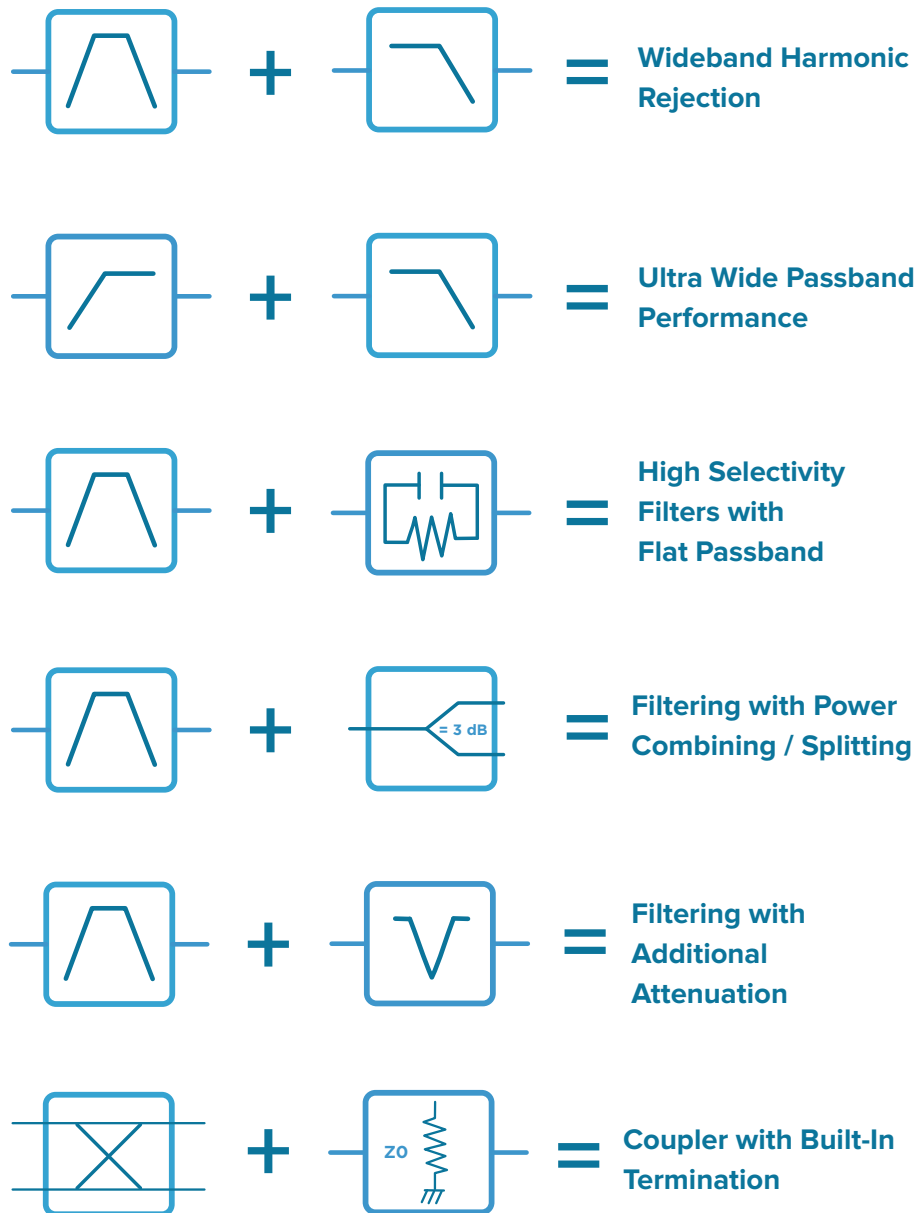

$\text{Reduced Footprint, Repeatable Performance}$
 $\text{N - Way Power Combiners / Dividers}$



Space Heritage

Our products are currently used worldwide and in space — in the most advanced military and aerospace instrumentation and communication systems.

SPACE APPLICATIONS

2024	Artemis Lunar Lander
2023	Griffin Lunar Lander
2022	Peregrine Lunar Lander
	NISAR (NASA-ISO Synthetic Aperture Radar)
	NISAR TROPICS
2021	SWOT (Surface Water Ocean Topography)
	JPSS2 (Joint Polar Satellite System 2)
	New Glenn Blue Origin
2019	New Shepard Blue Origin
2017	JPSS1 (Joint Polar Satellite System 1)
2015	OG2 (Orbcomm Generation 2)
	MMS (Magnetosphere Multiscale Mission)
	SMAP (Soil Moisture Active Passive)
2014	WorldView-3
2013	MUOS (Mobile User Objective System)

2011	Suomi NPP (National Polar-orbiting Partnership)
2010	SBSS (Space Based Space Surveillance)
2009	WISE (Wide-field Infrared Survey Explorer)
	WorldView-2 LM-900
2008	GLAST (Gamma Ray Large Space Telescope)
2008	JEM-PM (Japanese Experimental Module "Kibo" Pressurized Module)
Various 2002 -	ATLAS Launch Vehicle
Ongoing 1998-	ISS (International Space Station)
	C2V2 (Common Communication for Visiting Vehicle)
	CONNECT
	IPP

MARS & JUPITER MISSIONS

2026	Earth Return Orbiter
	Sample Return Lander
2023	Europa JUICE (Jupiter Icy Explorer)
	Europa RIME (Radar for Icy Moon Exploration)
2021	Orion
2020	Perseverance Rover
2018	InSight Lander (Interior exploration using Seismic Investigations, Geodesy and Heat Transport)
2016	ExoMars TGO (Trace Gas Orbiter)
2013	MAVEN (Mars Atmosphere and Volatile Evolution)
2011	Curiosity Sky Crane
	Curiosity Rover
2008	Phoenix Lander
2005	MRO (Mars Reconnaissance Orbiter)
2003	Opportunity Rover
	Spirit Rover

TESTING CAPABILITIES

RF PERFORMANCE TESTING

RF Performance GSG (ground signal ground)	100% or sample
RF Test Over Temperature	
Design Evaluation Boards	
Resistor Testing	100% or sample
TCR (Thermal Coefficient of Resistance)	MIL-STD-202, Method 304

ENVIRONMENTAL TESTING

Humidity	MIL-STD-202, Method 103
Immersion	MIL-STD-202, Method 104
Moisture Resistance	MIL-STD-202, Method 106
Thermal Shock	MIL-STD-202, Method 107
Temperature Cycling	MIL-STD-883, Method 1010

MECHANICAL TESTING

Constant Acceleration	MIL-STD-883, Method 2001
Mechanical Shock	MIL-STD-883, Method 2002
Solderability	MIL-STD-883, Method 2003
Visual	MIL-STD-883, Method 2008
External Visual	MIL-STD-883, Method 2009
Bond Strength	MIL-STD-883, Method 2011
Die Shear	MIL-STD-883, Method 2019
Ball Shear	ASTM 1269

PHYSICAL TESTING

Vibration	MIL-STD-202, Method 201
Resistance to Soldering Heat	MIL-STD-202, Method 210
Acceleration	MIL-STD-202, Method 212
DPA	EIA-469



Note: Standard test methods listed as capabilities. For each order, testing is carried out as specified by the customer on the SCD and PO.



SatCom Offerings

C BAND

PART NUMBER	TYPE	FREQUENCY RANGE, GHz	SIZE L X W X H, INCHES (mm)
B056RC4S	Bandpass Filter Octave	4.0-8.0	0.450 (11.43) x 0.230 (5.842) x 0.100 (2.54)
B038NC4S	Bandpass Filter Downlink	3.4-4.2	0.550 (13.97) x 0.220 (5.588) x 0.108 (2.743)
B040RG9S	Bandpass Filter Downlink	2.0-6.0	0.620 (15.75) x 0.280 (7.11) x 0.093 (2.36)
B061MB6S	Bandpass Filter Downlink	5.85-6.425	0.450 (11.43) x 0.200 (5.08) x 0.098 (2.48)
PDW06398	Power Divider 2:1 Splitter	5.0-7.0	0.120 (3.048) x 0.240 (6.096) x 0.015 (0.381)
FPC06700	Directional Coupler 3 dB	5.9-6.5	0.425 (10.80) x 0.250 (6.35) x 0.020 (0.508)
FPC06073	Directional Coupler 10 dB	4.0-8.0	0.170 (4.318) x 0.080 (2.032) x 0.015 (0.381)
FPC06149	Directional Coupler 10 dB	4.0-8.0	0.180 (4.572) x 0.080 (2.032) x 0.015 (0.381)
FPC06076	Directional Coupler 20 dB	4.0-8.0	0.170 (4.318) x 0.080 (2.032) x 0.015 (0.381)
FPC06152	Directional Coupler 20 dB	4.0-8.0	0.180 (4.572) x 0.080 (2.032) x 0.015 (0.381)

X BAND

PART NUMBER	TYPE	FREQUENCY RANGE, GHz	SIZE L X W X H, INCHES (mm)
B096QC2S	Bandpass Filter Octave	8.0-12.0	0.400 (10.16) x 0.180 (4.572) x 0.100 (2.54)
PDW06399	Power Divider 2:1 Splitter	9.0-11.0	0.150 (3.81) x 0.100 (2.54) x 0.015 (0.381)
FPC06630	Directional Coupler 3 dB	9.0-11.0	0.286 (7.264) x 0.180 (4.572) x 0.015 (0.381)
FPC06074	Directional Coupler 10 dB	8.0-12.0	0.120 (3.048) x 0.080 (2.032) x 0.015 (0.381)
FPC06150	Directional Coupler 10 dB	8.0-12.0	0.130 (3.302) x 0.090 (2.286) x 0.015 (0.381)
FPC06153	Directional Coupler 20 dB	8.0-12.0	0.130 (3.302) x 0.090 (2.286) x 0.015 (0.381)
FPC06302	Directional Coupler 20 dB	8.0-12.0	0.120 (3.048) x 0.080 (2.032) x 0.015 (0.381)
FPC06701	Directional Coupler 3 dB	10.7-12.75	0.255 (6.48) x 0.155 (3.94) x 0.015 (0.381)

KU BAND

PART NUMBER	TYPE	FREQUENCY RANGE, GHz	SIZE L X W X H, INCHES (mm)
B119LB1S	Bandpass Filter Downlink	11.7-12.2	0.450 (11.43) x 0.200 (5.08) x 0.098 (2.488)
B119MB1S	Bandpass Filter Downlink	4.0-10.0	0.450 (11.43) x 0.200 (5.08) x 0.098 (2.488)
B142LA2S	Bandpass Filter Downlink	14.0-14.5	0.575 (14.60) x 0.200 (5.08) x 0.093 (2.36)
PDW06400	Power Divider 2:1 Splitter	11.0-13.0	0.130 (3.302) x 0.130 (3.302) x 0.015 (0.381)
PDW06401	Power Divider 2:1 Splitter	15.0-17.0	0.120 (3.048) x 0.120 (3.048) x 0.015 (0.381)
FPC06075	Directional Coupler 10 dB	12.0-18.0	0.100 (2.54) x 0.080 (2.032) x 0.015 (0.381)
FPC06151	Directional Coupler 10 dB	12.0-18.0	0.100 (2.54) x 0.080 (2.032) x 0.015 (0.381)
FPC06078	Directional Coupler 20 dB	12.0-18.0	0.100 (2.54) x 0.080 (2.032) x 0.015 (0.381)
FPC06164	Directional Coupler 20 dB	12.0-18.0	0.100 (2.54) x 0.080 (2.032) x 0.015 (0.381)

KA BAND

PART NUMBER	TYPE	FREQUENCY RANGE, GHz	SIZE L X W X H, INCHES (mm)
B289KA0S	Bandpass Filter Uplink	28.6-29.1	0.550 (13.97) x 0.140 (3.556) x 0.088 (2.235)
B291MB0S	Bandpass Filter Uplink	3.0-10.0	0.450 (11.43) x 0.140 (3.556) x 0.088 (2.235)
B305LA0S	Bandpass Filter Uplink	3.5-10.0	0.550 (13.97) x 0.140 (3.556) x 0.078 (1.981)
PDW06984	Power Divider 2:1 Splitter	25.0-32.0	0.085 (2.159) x 0.095 (2.413) x 0.010 (0.254)
PDW07069	Power Divider 4:1 Splitter	24.0-32.0	0.140 (3.556) x 0.170 (4.318) x 0.010 (0.254)
PDW07630	Power Divider 2:1 Splitter	25.0-32.0	0.070 (1.778) x 0.070 (1.778) x 0.010 (0.254)
FPC07182	Directional Coupler 10 dB	20.0-40.0	0.065 (1.651) x 0.050 (1.27) x 0.010 (0.254)
FPC07181	Directional Coupler 20 dB	20.0-40.0	0.065 (1.651) x 0.050 (1.27) x 0.010 (0.254)



DLI Brand Device Selection

FREQUENCY 800MHZ TO 67 GHZ

Do you need a custom order or a catalog part? We are here to help, email us DLIengineering@knowles.com.

Applications

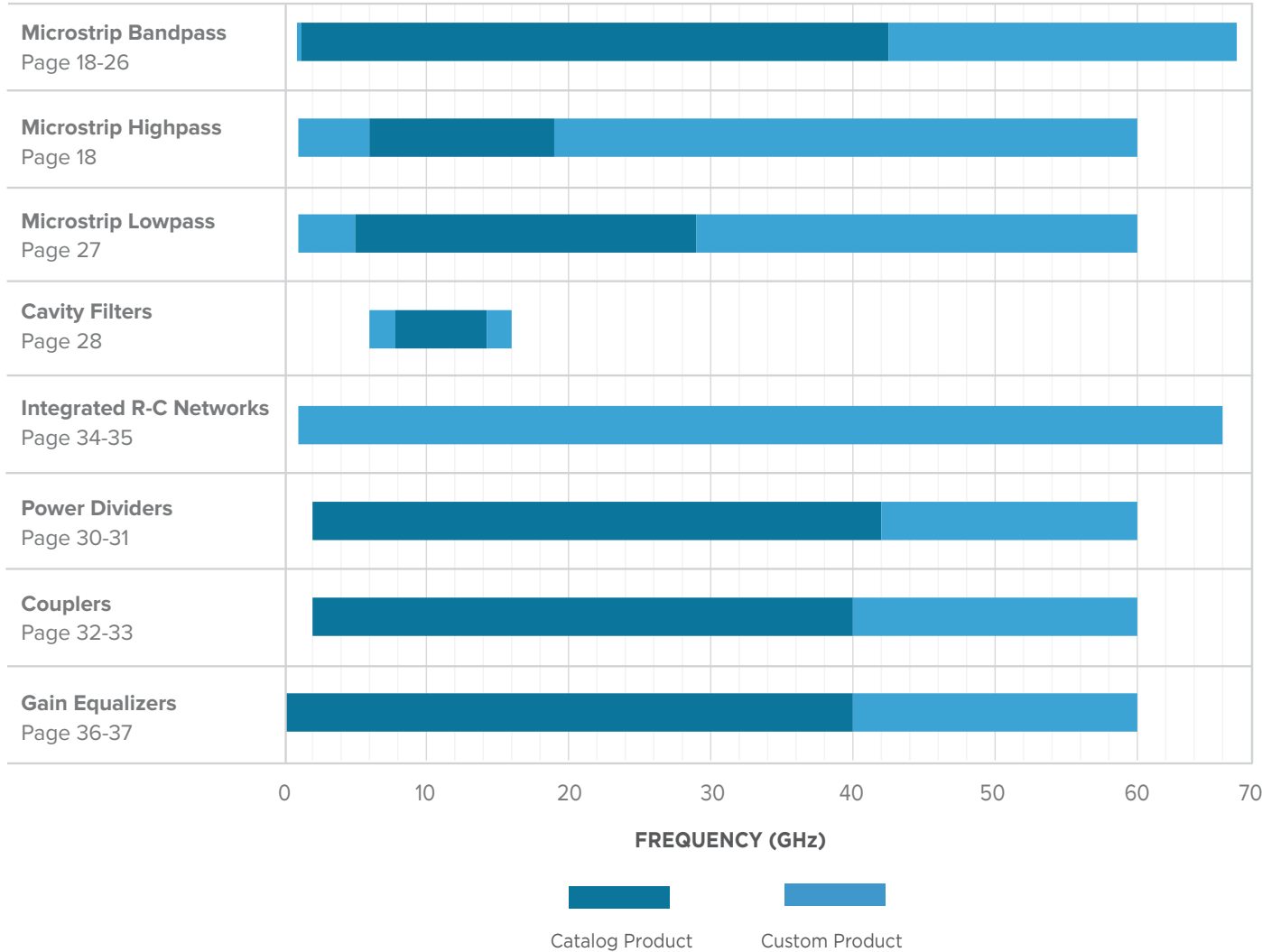

KEY FEATURES AND BENEFITS OF ALL OUR MICROWAVE PRODUCTS

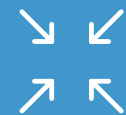

Small Size



Frequency Stable Over Temperature



Operating Temperature: -55°C to +125°C



Excellent Repeatability



Solder Surface Mount Package



Ceramic Advantages

Why do DLI brand devices have exceptional performance?

The specialized attributes of our ceramic substrate materials

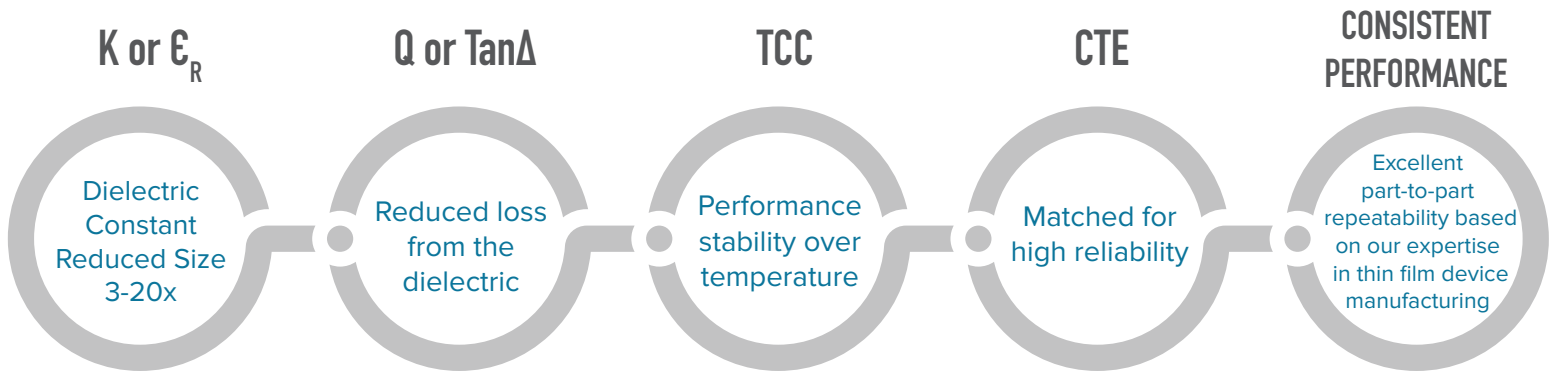

Relative Filter Size Compared by Material

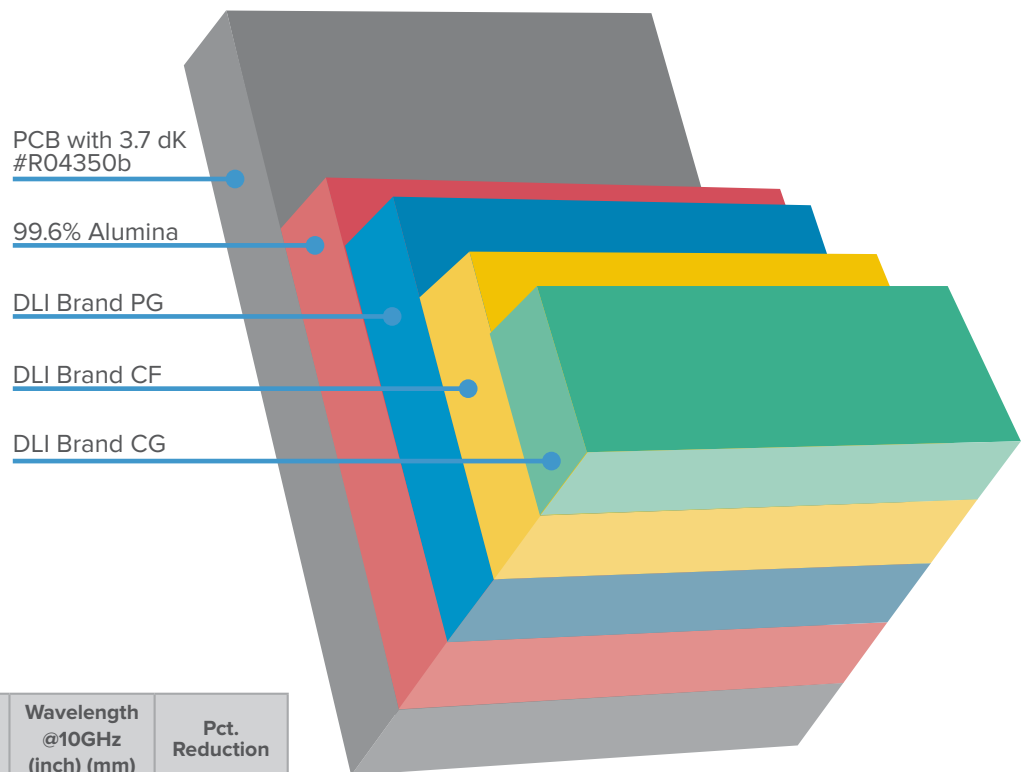

Filter Characteristics Compared by Material

Material	dK	Effective K**	Wavelength @10GHz (inch) (mm)	Pct. Reduction
PCB with Dk #R04350b	3.7	2.8	0.707 [17.96]	-----
99.6% Alumina	9.6	6.5	0.462 [11.73]	34.7%
DLI Brand PG	12.5	8.2	0.412 [10.46]	41.7%
DLI Brand CF	25	15.1	0.304 [7.72]	57.0%
DLI Brand CG	67	36.8	0.194 [4.93]	72.6%

**Values are for Freq. 10GHz on 0.010" Substrate



Microstrip Filter Overview

BANDPASS

DLI bandpass filters are designed for high-performance microwave applications in a surface mountable package. Using temperature-stable, high-permittivity dielectrics and thin-film processing, these designs offer high selectivity without sacrificing in-band performance.

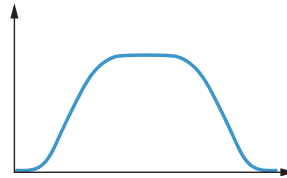

HIGHPASS

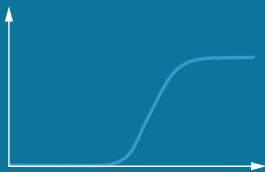

DLI's selection of lowpass and highpass filters aims to provide a drop-in solution for high-frequency attenuation. These filters have extreme repeatability, therefore multiple filters can be placed in series for increased rejection.

LOWPASS



DESIGN ADVANTAGES:

- Miniaturization enabled by specialty high-Q ceramics
- Fully shielded component
- Surface mount device configuration available
- Consistent performance
- 100% testing before ship



APPLICATIONS:



5G



Aerospace



Military



Telecom



Satellite Communications



KEY CHARACTERISTICS:

- Low variation over a wide temperature range
- Integrated RF shielding
- Characteristic impedance: 50Ω
- Moisture sensitivity level: MSL1
- No ESD sensitivity

CERTIFICATION:



SAI GLOBAL
ISO 9001
Quality



SAI GLOBAL
AS9100
Aerospace



Filter Catalog

Part Number Structure

L	0	6	0	X	D	9	S
Filter type code	10 GHz Place Value	1 GHz Place Value	0.1 GHz Place Value	% BW Code	30 dB Rejection Level Code	Re-entrance Code	Package Code

FILTER TYPE CODE	
CODE	FILTER TYPE
B	BANDPASS
L	LOWPASS
H	HIGHPASS
C	CAVITY
N	NOTCH

PACKAGE CODE	
CODE	FILTER TYPE
W	WIRE-BOND
S	SMD

% BW CODE	
CODE	3DB% BW
J	0 - 1%
K	> 1 - 5%
L	> 5 - 10%
M	> 10 - 20%
N	> 30 - 40%
O	> 40 - 50%
P	> 50 - 60%
Q	> 50 - 60%
R	> 60%
X	LPF & HPF

30 DB REJECTION LEVEL CODE	
CODE	% OFF 3 DB CORNER
A	0 - 2%
B	> 2 - 4%
C	> 4 - 6%
D	> 6 - 8%
E	> 8 - 10%
F	> 10 - 15%
G	> 15 - 20%
H	> 20%

Notes:
 LPF & HPF: Percentage off of 3db corner
 BPF: Average percentage off 3dB BW
 Notch: Average percentage 3dB BW to 10dB BW

RE-ENTRANCE CODE	
CODE	RE-ENTRANT MULTIPLIED
0	1.2 - 1.4
1	> 1.4 - 1.6
2	> 1.6 - 1.8
3	> 1.8 - 2.0
4	> 2.0 - 2.2
5	> 2.2 - 2.4
6	> 2.4 - 2.6
7	> 2.6 - 3.8
8	> 2.8 - 3.0
9	> 3.0
X	HPF

Notes:
 Re-entrance is multiplier past the highside 30dB rejection level.
 Notch: Multiplier from corner of first notch to center or second notch

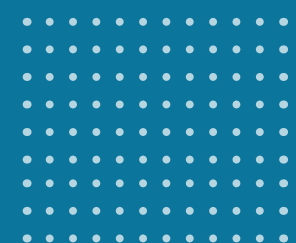

Bandpass Filter Ordering Information

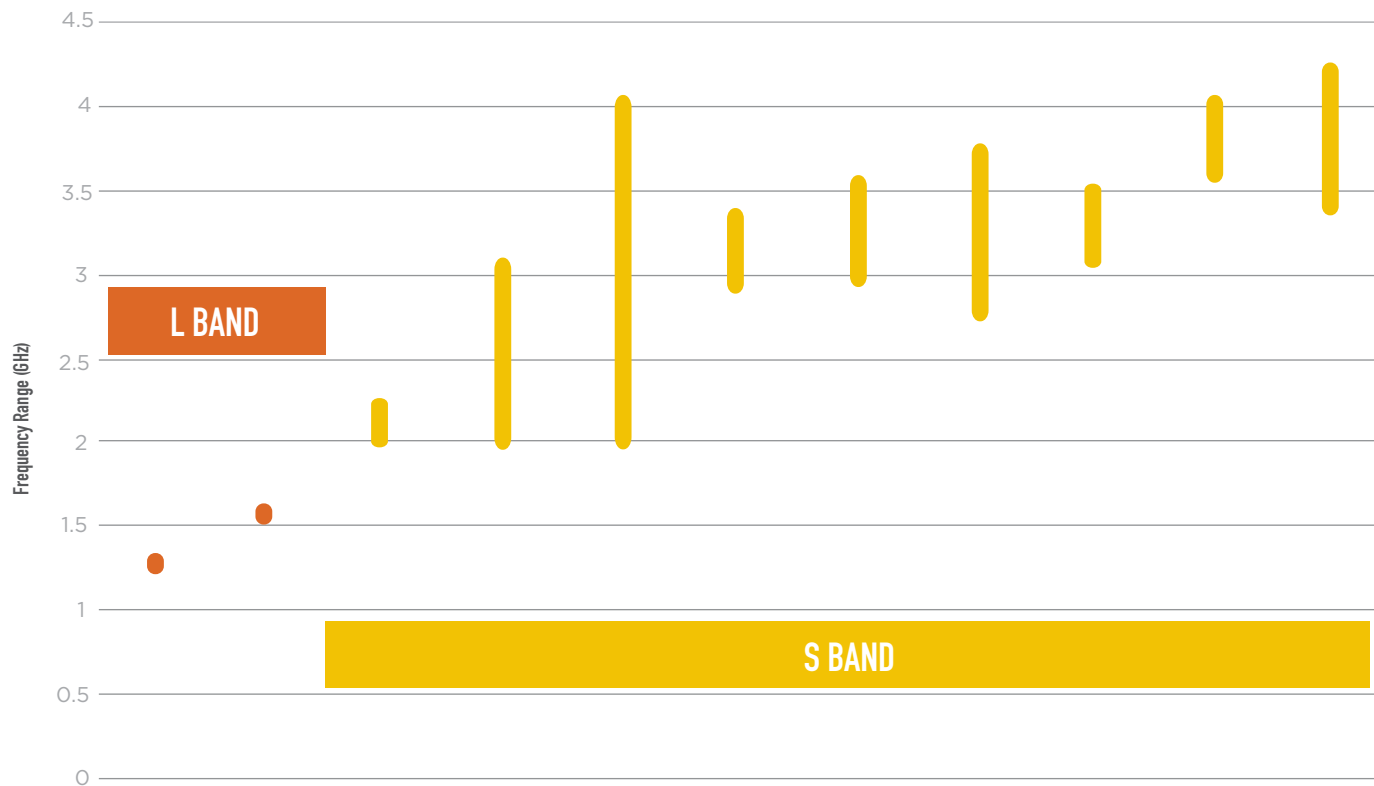

Part Number	B012MD5S	B016MD6S	B021MC8S	B024RF2S	B028RF2S	B031ND5S	B032ND5S	B032OD5S	B033ND5S	B038MC9S	B038NC4S
Center Frequency (GHz)	1.227	1.575	2.1	2.4	2.8	3.1	3.24	3.25	3.3	3.8	3.8
Bandwidth (GHz)	0.01	0.01	0.01	1.08	2	0.43	0.6	1	0.4	0.38	0.8
Insertion Loss											
@ 25°C (dB)	3.5	3.5	3	3	2	3	3	3	2	4	2.25
-40°C to +85°C (dB)	4.2	4.2	3.5	3.5	3	3.5	3.5	3.5	3.2	4.5	2.5
VSWR	2.0:1	2.0:1	2.0:1	2.0:1	1.63:1	2.0:1	1.67:1	1.67:1	2.0:1	2.0:1	2.0:1
Rejection											
Amplitude (dB)	40	40	40	40	40	40	40	40	40	40	40
LS Range (GHz)	DC - 0.925	DC - 1.175	DC - 1.7	DC - 1.25	DC - 1.25	DC - 2.4	DC - 2.3	DC - 1.875	DC - 2.25	DC - 3.22	DC - 2.8
HS Range (GHz)	1.45 - 2.5	1.875 - 3.0	2.5 - 6	3.8 - 4.75	4.85 - 6.0	3.85 - 7.0	4.1 - 7.0	4.125 - 6	4.0 - 6.0	4.45 - 13	4.7 - 8.9
Dimensions (inches)											
Length	0.460	0.460	0.6	0.500	0.450	0.500	0.500	0.360	0.393	0.500	0.550
Width	0.460	0.460	0.3	0.250	0.400	0.250	0.250	0.260	0.353	0.250	0.220
Height	0.113	0.113	0.118	0.110	0.113	0.100	0.110	0.098	0.128	0.098	0.098
Dimensions (mm)											
Length	11.68	11.68	15.24	12.70	11.43	12.70	12.70	9.14	9.98	12.70	13.97
Width	11.68	11.68	7.62	6.35	10.16	6.35	6.35	6.60	8.97	6.35	5.59
Height	2.87	2.87	3.00	2.79	2.87	2.54	2.79	2.49	3.25	2.49	2.49



Bandpass Filter Ordering Information

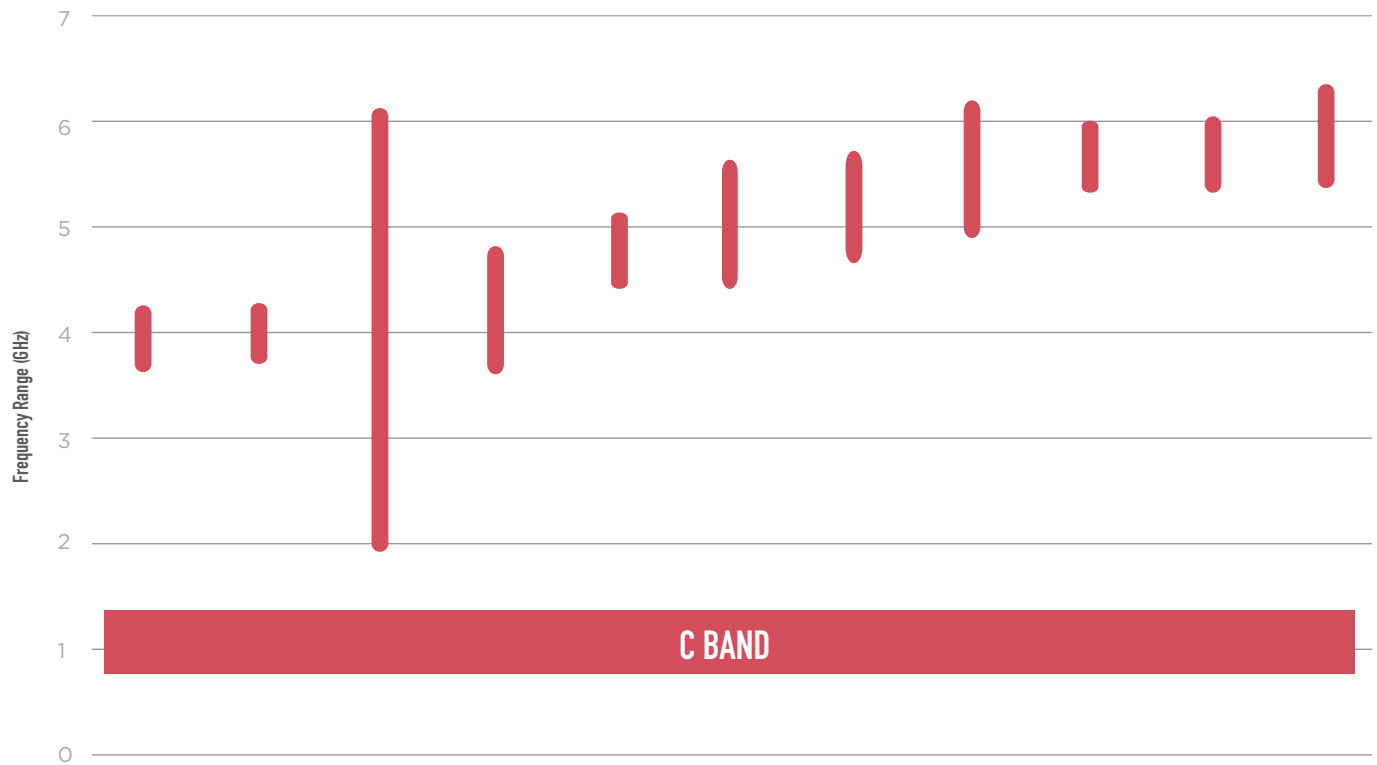

Part Number	B039NC5S	B040MB5S	B040RG9S	B0420D4S	B047MC5S	B050ND4S	B052NC5S	B055NC5S	B056MB5S	B057MC5S	B058MD7S
Center Frequency (GHz)	3.95	4	4	4.2	4.7	5	5.2	5.5	5.6	5.7	5.8
Bandwidth (GHz)	0.5	0.44	4	1	0.6	1	0.8	1	0.05	0.5	0.6
Insertion Loss											
@ 25°C (dB)	2.5	2.5	2.75	3	2	2	2.25	2	2	2	2.3
-40°C to +85°C (dB)	2.75	2.75	3.25	3.5	2.5	2.5	2.75	2.5	2.5	2.5	2.8
VSWR	2.0:1	2.0:7	2.0:1	1.67:1	2.0:1	1.58:1	1.67:1	2.0:12	2.0:13	1.67:1	1.67:1
Rejection											
Amplitude (dB)	40	40	40	40	40	40	40	40	40	40	40
LS Range (GHz)	DC - 3.0	DC - 3.4	DC - 0.75	DC - 3.0	DC - 3.8	DC - 3.65	DC - 3.5	DC - 4.2	DC - 4.8	DC - 4.7	DC - 4.65
HS Range (GHz)	4.8 - 8.0	4.6 - 10.0	7.25 - 18.75	5.6 - 10.0	5.5 - 11.0	6.15 - 12.0	6.2 - 12.5	6.75 - 12.0	6.75 - 14.0	6.6 - 14.25	7.0 - 16.0
Dimensions (inches)											
Length	0.500	0.500	0.590	0.500	0.500	0.350	0.350	0.350	0.440	0.350	0.048
Width	0.250	0.250	0.280	0.250	0.250	0.200	0.200	0.200	0.240	0.200	0.275
Height	0.110	0.100	0.093	0.110	0.100	0.098	0.095	0.095	0.098	0.110	0.103
Dimensions (mm)											
Length	12.70	12.70	14.99	12.70	12.70	8.89	8.89	8.89	11.18	8.89	1.21
Width	6.35	6.35	7.11	6.35	6.35	5.08	5.08	5.08	6.10	5.08	6.99
Height	2.79	2.54	2.36	2.79	2.54	2.49	2.41	2.41	2.49	2.79	2.62



Bandpass Filter Ordering Information

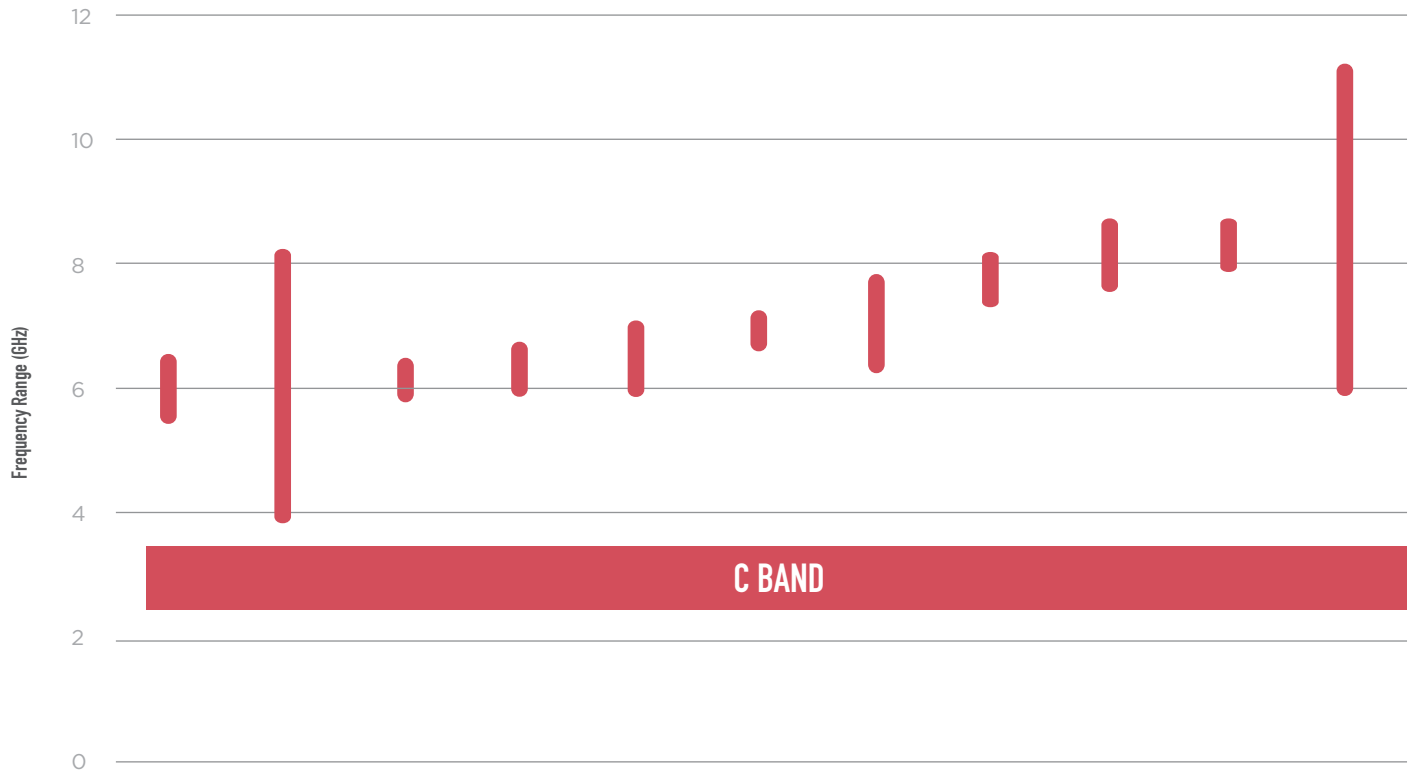

Part Number	B060NC5S	B056RC4S	B061MB6S	B062MC5S	B065NC5S	B070MB6S	B070NC5S	B076MB6S	B080MB5S	B083LB6S	B081RC0S
Center Frequency (GHz)	6	5.6	6.1	6.3	6.5	7.1	7	7.6	8	8.3	8.1
Bandwidth (GHz)	1	4	0.5	0.8	1	0.55	1.26	0.72	1	0.5	5
Insertion Loss											
@ 25°C (dB)	2	3	3	2.5	3	2.5	2	2.5	2	2.5	3.4
-40°C to +85°C (dB)	3	3.5	3.5	2.75	3.5	2.75	2.5	2.75	3	2.75	3.9
VSWR	1.29:1	1.5:1	2.0:1	1.67:1	1.67:1	2.0:1	2.0:1	2.2:1	1.29:1	1.92:1	2.0:1
Rejection											
Amplitude (dB)	40	40	40	40	40	40	40	40	40	40	40
LS Range (GHz)	DC - 4.9	DC - 3.0	DC - 5.25	DC - 5.2	DC - 5.2	DC - 6.2	DC - 5.8	DC - 6.69	DC - 6.8	DC - 8.825	DC - 3.5
HS Range (GHz)	7.1 - 14.0	9.5 - 12.0	7.25 - 16.0	7.5 - 15.0	7.75 - 15.0	7.8 - 15.0	8.5 - 17.5	8.52 - 18.25	9.25 - 17.0	11.35 - 16.5	14.0 - 19.0
Dimensions (inches)											
Length	0.500	0.450	0.450	0.500	0.500	0.500	0.500	0.500	0.500	0.450	0.190
Width	0.200	0.230	0.200	0.250	0.250	0.200	0.200	0.200	0.180	0.200	0.100
Height	0.088	0.100	0.098	0.095	0.095	0.100	0.100	0.100	0.100	0.103	0.090
Dimensions (mm)											
Length	12.70	11.43	11.43	12.70	12.70	12.70	12.70	12.70	12.70	11.43	4.83
Width	5.08	5.84	5.08	6.35	6.35	5.08	5.08	5.08	4.57	5.08	2.54
Height	2.24	2.54	2.49	2.41	2.41	2.54	2.54	2.54	2.54	2.62	2.29



Bandpass Filter Ordering Information

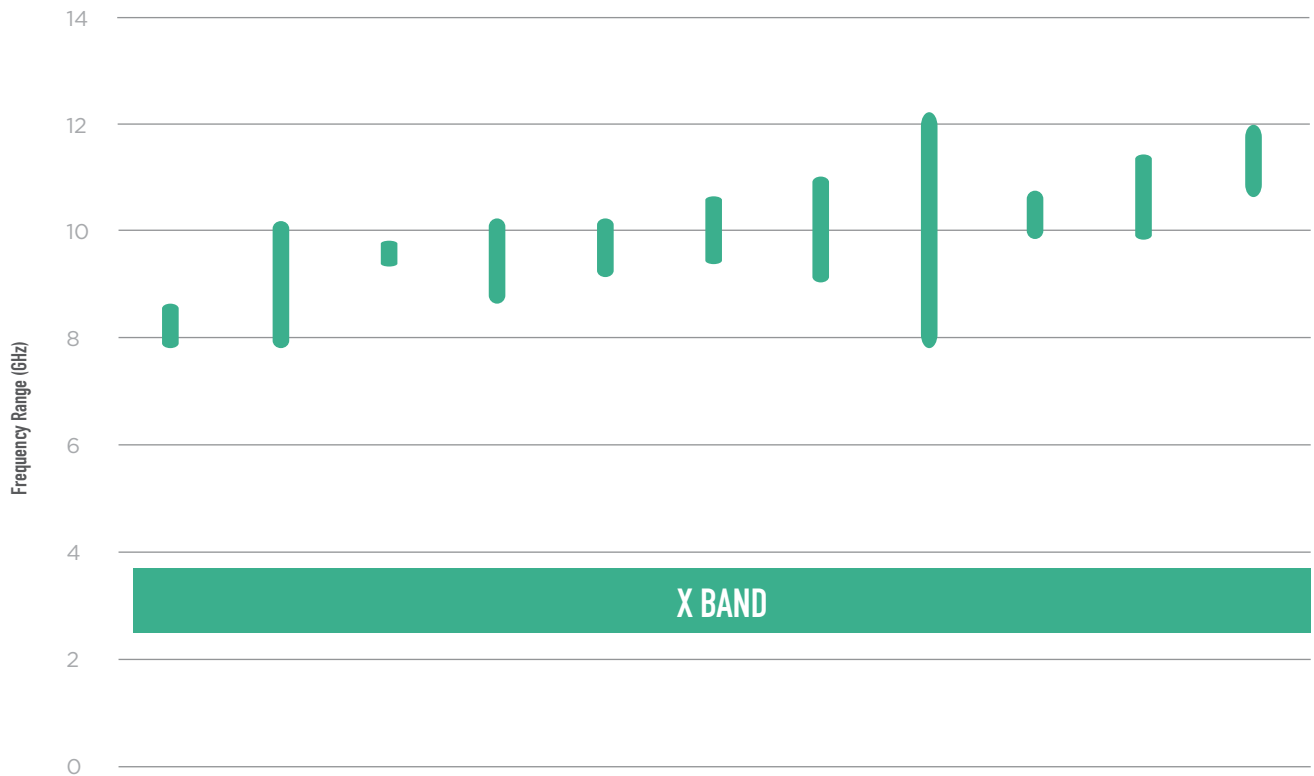

Part Number	B084MC6S	B089NC4S	B094LA2S	B095MB1S	B097MB0S	B100MC5S	B099NC4S	B096QC2S	B102MC1S	B105MB5S	B112MB1S
Center Frequency (GHz)	8.4	8.9	9.4	9.5	9.7	10	10.25	10	10.25	10.6	11.2
Bandwidth (GHz)	0.84	2	0.35	1.1	0.8	1	2.25	4	0.5	1.2	1
Insertion Loss											
@ 25°C (dB)	4	2.5	2.75	1.75	2.5	2	2.25	2.5	2.25	1.75	2.25
-40°C to +85°C (dB)	4.5	2.75	3	2	2.75	2.5	2.25	3	2.25	2	2.75
VSWR	2.0:1	1.92:1	1.58:1	1.92:1	1.92:1	1.92:1	1.58:1	2.0:1	1.92:1	1.92:1	1.92:1
Rejection											
Amplitude (dB)	40	40	40	40	40	40	40	40	40	40	40
LS Range (GHz)	DC - 7.1	DC - 6.8	DC - 8.6	DC - 8.0	DC - 8.1	DC - 8.5	DC - 8.5	DC - 6.0	DC - 9.0	DC - 8.0	DC - 9.4
HS Range (GHz)	21-Oct	11.25 - 20.0	10.25 - 15.0	11.5 - 20.0	11.35 - 23.0	11.75 - 20.0	11.75 - 20.0	14.0 - 18.0	11.35 - 16.5	13.0 - 23.5	13.25 - 20.0
Dimensions (inches)											
Length	0.6	0.400	0.450	0.400	0.400	0.400	0.400	0.400	0.450	0.450	0.400
Width	0.3	0.150	0.200	0.150	0.150	0.150	0.150	0.180	0.200	0.200	0.150
Height	0.093	0.103	0.098	0.103	0.103	0.098	0.098	0.100	0.090	0.103	0.103
Dimensions (mm)											
Length	15.24	10.16	11.43	10.16	10.16	10.16	10.16	10.16	11.43	11.43	10.16
Width	7.62	3.81	5.08	3.81	3.81	3.81	3.81	4.57	5.08	5.08	3.81
Height	2.36	2.62	2.49	2.62	2.62	2.49	2.29	2.54	2.29	2.62	2.62



Bandpass Filter Ordering Information

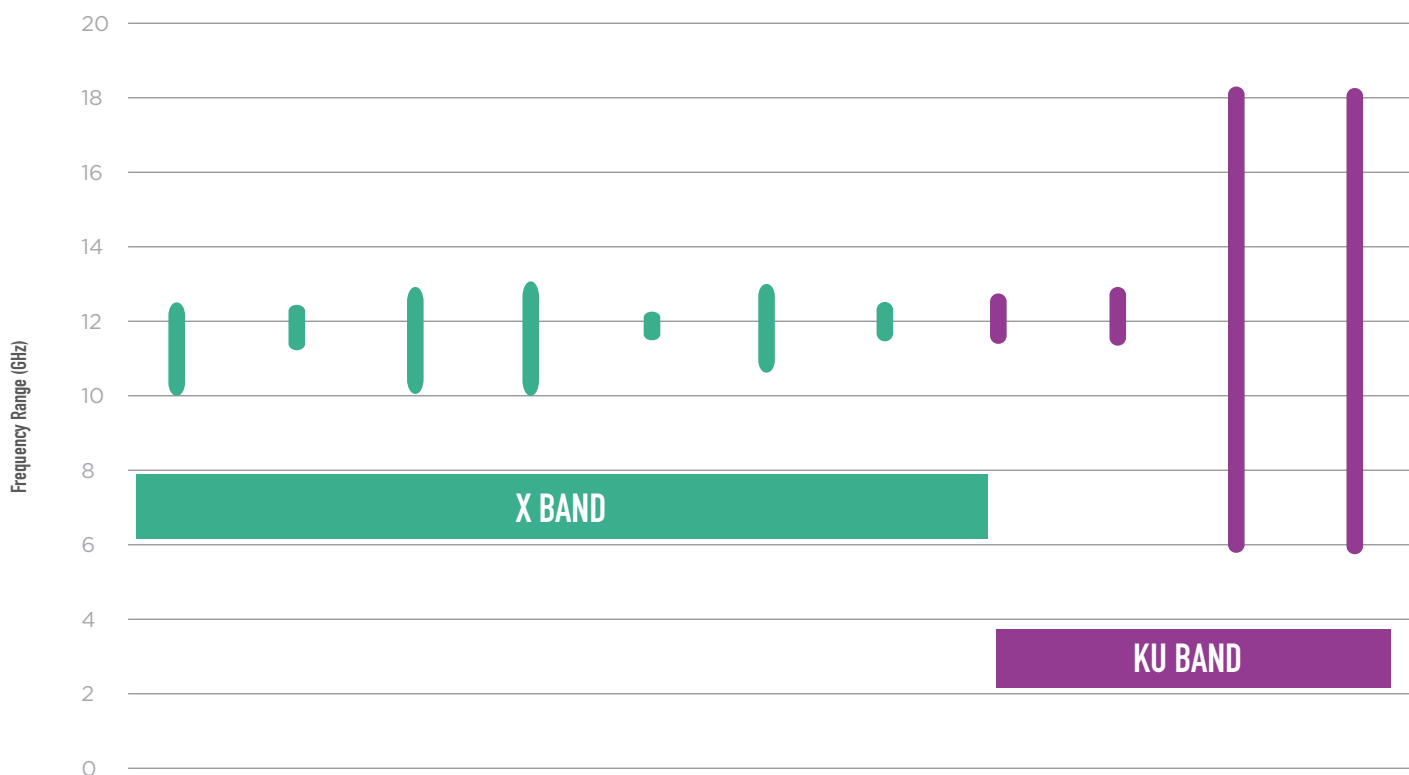

Part Number	B111NC4S	B114MB1S	B115NB4S	B116NC5S	B118LB4S	B119MB1S	B119LB1S	B120MB1S	B121MB4S	B120RF0S	B120RF0W
Center Frequency (GHz)	11.2	11.4	11.6	11.4	11.8	11.9	11.9	12	12	12	12
Bandwidth (GHz)	2.5	1.1	2.5	2.25	0.5	2.7	2.2	1	1.5	12	12
Insertion Loss											
@ 25°C (dB)	2.25	3.5	2.5	2.25	2.5	3	3.25	2	2.5	2.5	2.5
-40°C to +85°C (dB)	2.25	4	2.75	2.5	2.75	3.75	3.75	3	3	3	3
VSWR	1.92:1	2.0:1	1.92:1	1.92:1	1.58:1	1.92:1	2.0:1	1.29:1	1.92:1	2.0:1	2.0:1
Rejection											
Amplitude (dB)	40	40	40	40	40	40	40	40	40	40	40
LS Range (GHz)	DC - 8.75	DC - 10	DC - 9.5	DC - 9.0	DC - 10.25	DC - 9.8	DC - 10.75	DC - 10.6	DC - 9.5	DC - 3.3	DC - 3.3
HS Range (GHz)	14.5 - 25.0	13 - 18.25	14.5 - 23.0	14.25 - 23.5	13.25 - 18.0	13.9 - 20.0	13 - 19.5	13.2 - 19.5	14.5 - 24.25	19.8 - 22.0	19.8 - 22.0
Dimensions (inches)											
Length	0.400	0.400	0.575	0.400	0.450	0.450	0.450	0.525	0.400	0.450	0.450
Width	0.150	0.200	0.200	0.150	0.200	0.200	0.200	0.225	0.150	0.200	0.200
Height	0.090	0.093	0.093	0.090	0.103	0.098	0.098	0.090	0.103	0.103	0.103
Dimensions (mm)											
Length	10.16	10.16	14.61	10.16	11.43	11.43	11.43	13.34	10.16	11.43	11.43
Width	3.81	5.08	5.08	3.81	5.08	5.08	5.08	5.72	3.81	5.08	5.08
Height	2.29	2.36	2.36	2.29	2.62	2.49	2.49	2.29	2.62	2.62	2.62



Bandpass Filter Ordering Information

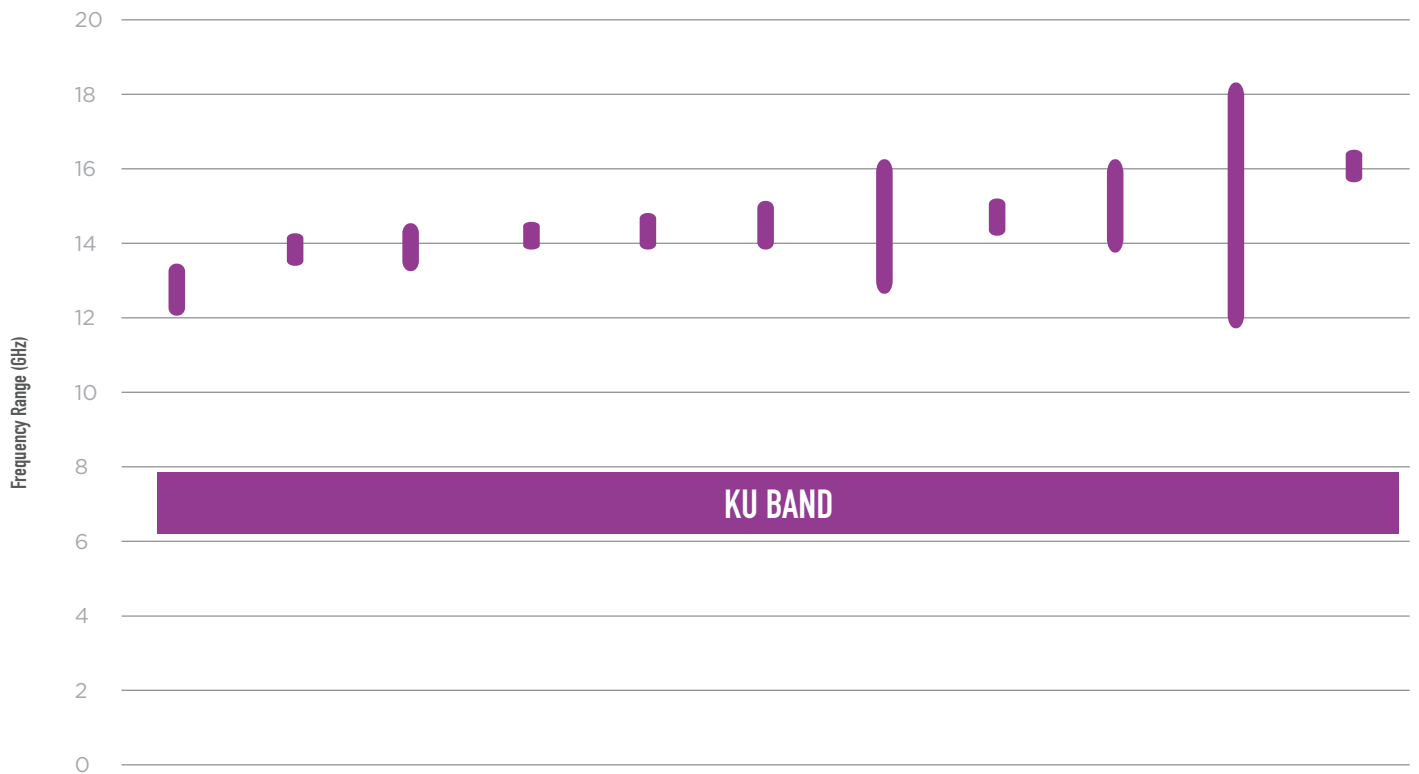

Part Number	B127MB2S	B138LA2S	B138MB1S	B142LA2S	B145LB1S	B144MB1S	B1500G0S	B148LA2S	B149MC1S	B148QF0S	B160KA1S
Center Frequency (GHz)	12.75	13.75	13.75	14.2	14.5	14.5	14.5	14.75	15	15	16
Bandwidth (GHz)	1	0.5	1	0.5	0.8	1	3	0.5	2	6	0.5
Insertion Loss											
@ 25°C (dB)	2.75	2.75	2.75	4.5	3.5	2.4	2.25	3.25	2.25	3.6	2.75
-40°C to +85°C (dB)	3	3.25	3	5	3.75	2.5	2.5	3.5	2.5	4.2	3
VSWR	1.58:1	1.58:1	1.58:1	2.0:1	2.0:1	1.58:1	1.58:1	1.58:1	1.58:1	1.63:1	1.58:1
Rejection											
Amplitude (dB)	40	40	40	40	40	40	40	40	40	40	40
LS Range (GHz)	DC - 10.75	DC - 12.5	DC - 11.75	DC - 13.25	DC - 12.5	DC - 12.25	DC - 10.5	DC - 13.25	DC - 11.0	DC - 7.6	DC - 14.25
HS Range (GHz)	14.25 - 19.75	14.75 - 22.00	15.25 - 21.00	15.25 - 25.0	16 - 22.25	16.25 - 22.0	18.0 - 25.0	16.0 - 20.0	18.5 - 23.0	23.0 - 25.0	17.75 - 20.5
Dimensions (inches)											
Length	0.400	0.450	0.400	0.575	0.550	0.400	0.375	0.450	0.350	0.550	0.400
Width	0.200	0.180	0.200	0.200	0.230	0.200	0.140	0.180	0.200	0.150	0.200
Height	0.098	0.098	0.098	0.093	0.093	0.098	0.093	0.098	0.098	0.098	0.098
Dimensions (mm)											
Length	10.16	11.43	10.16	14.61	13.97	10.16	9.53	11.43	8.89	13.97	10.16
Width	5.08	4.57	5.08	5.08	5.84	5.08	3.56	4.57	5.08	3.81	5.08
Height	2.49	2.49	2.49	2.36	2.36	2.49	2.36	2.49	2.49	2.49	2.49



Bandpass Filter Ordering Information

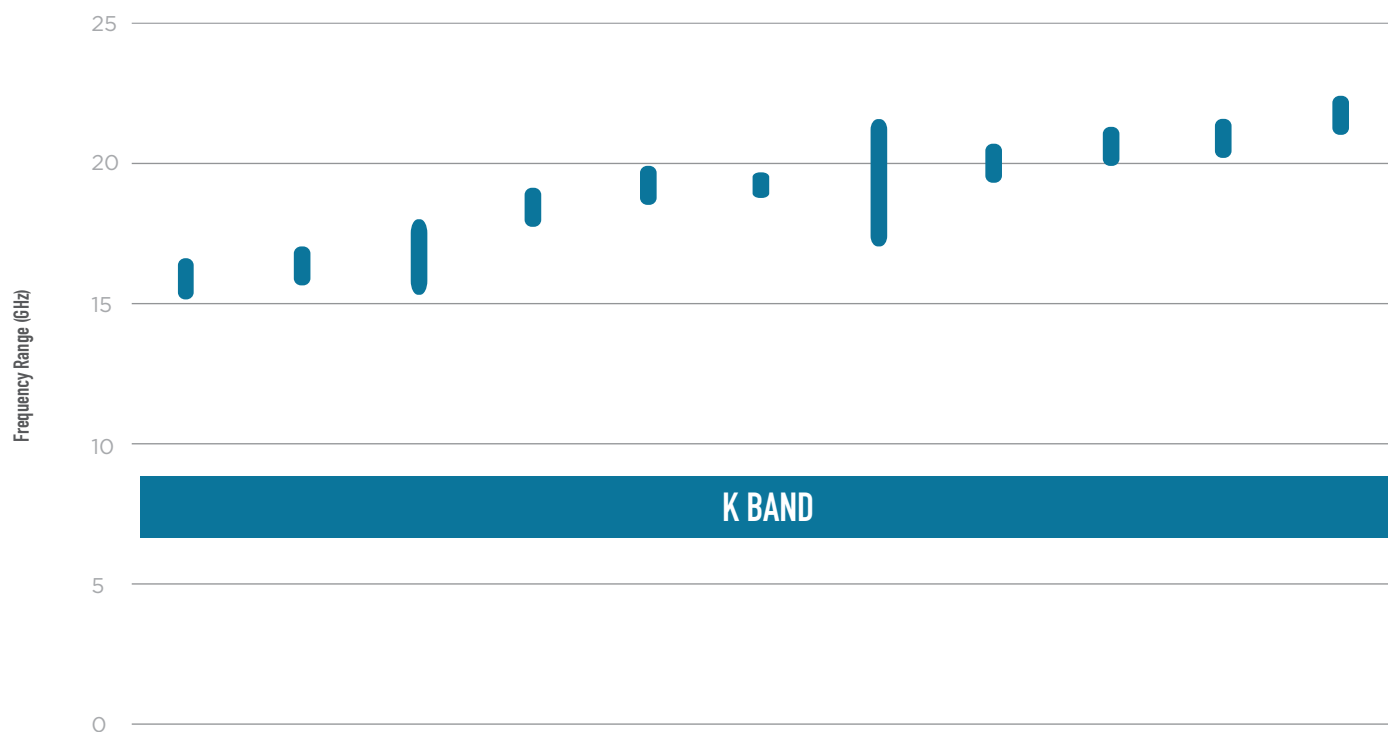

Part Number	B161LA0S	B165LA1S	B168MB1S	B180MA1S	B190MB1S	B191KA1S	B192NB2S	B200LA0S	B207LA0S	B210LA0S	B220LA0S
Center Frequency (GHz)	16	16.5	16.75	18	19	19.1	19.2	20	20.7	21	22
Bandwidth (GHz)	1	1	2	1	1	0.5	4	1	1	1	1
Insertion Loss											
@ 25°C (dB)	4	2.75	2.5	3	3	4.5	3.75	3	3.75	3.25	4
-40°C to +85°C (dB)	6	3	2.75	3.25	3.25	5	4.25	3.5	4.25	3.75	4.25
VSWR	1.67:1	1.58:1	1.58:1	2.0:1	2.0:1	2.0:1	1.92:1	1.92:1	2.0:1	2.0:1	2.0:1
Rejection											
Amplitude (dB)	40	40	40	40	40	40	40	40	40	40	40
LS Range (GHz)	DC - 14.75	DC - 14.5	DC - 13.4	DC - 16.25	DC - 17.0	DC - 18.0	DC - 15.0	DC - 18.25	DC - 18.7	DC - 19.25	DC - 20.25
HS Range (GHz)	17.3 - 22.00	18.0 - 25.0	19.25 - 24.00	19.5 - 27.5	20.75 - 27.0	20.0 - 26.0	23.25 - 35.0	21.35 - 28.0	22.4 - 27.0	22.75 - 26.75	23.75 - 28.6
Dimensions (inches)											
Length	0.695	0.400	0.350	0.450	0.450	0.575	0.450	0.450	0.450	0.450	0.450
Width	0.250	0.200	0.200	0.175	0.175	0.200	0.140	0.175	0.175	0.175	0.140
Height	0.093	0.098	0.098	0.093	0.093	0.093	0.088	0.093	0.093	0.093	0.088
Dimensions (mm)											
Length	17.65	10.16	8.89	11.43	11.43	14.61	11.43	11.43	11.43	11.43	11.43
Width	6.35	5.08	5.08	4.45	4.45	5.08	3.56	4.45	4.45	4.45	3.56
Height	2.36	2.49	2.49	2.36	2.36	2.36	2.24	2.36	2.36	2.36	2.24



Bandpass Filter Ordering Information

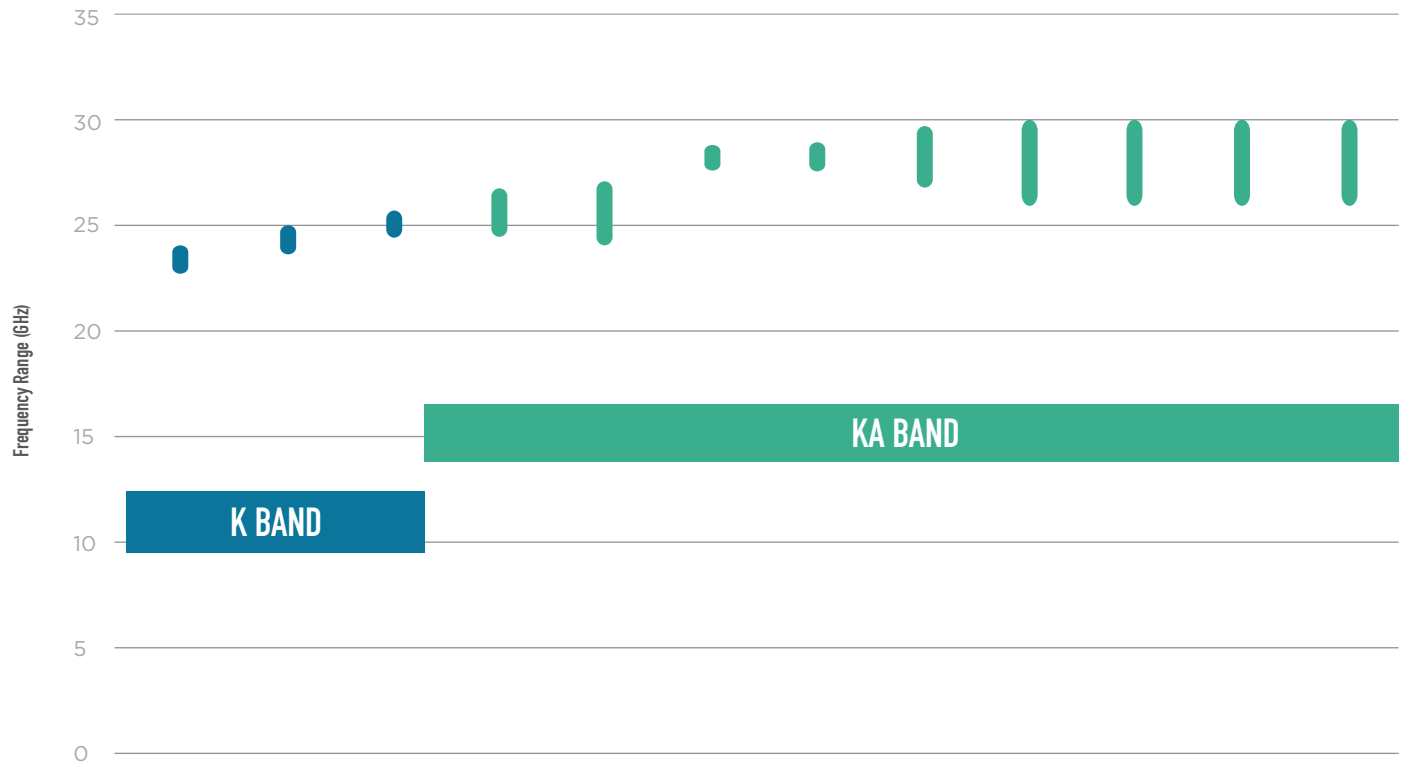

Part Number B230LA0S B240LA0S B250LA0S B260MB2S B259MC1S B279KB1S B280LA0S B280LB0S B274MB1S B280MC1S B280MD1S B280MF1S

Center Frequency (GHz)	23	24	25	26	26	27.9	28	28	28	28	28	28
Bandwidth (GHz)	1	1	1	3	3.25	0.85	1	2	3	3	3	3
Insertion Loss												
@ 25°C (dB)	4	4	4	5	4	3.75	4.5	2	3.5	3.5	3	3
-40°C to +85°C (dB)	4.5	4.5	4.5	5.25	4.25	4.25	4.75	2.5	3.75	4	3.5	3.25
VSWR	2.0:1	2.0:1	2.0:1	1.58:1	1.58:1	1.58:1	1.92:1	1.58:1	1.58:1	1.58:1	1.58:1	1.58:1
Rejection												
Amplitude (dB)	40	40	40	40	30	40	30	40	40	30	35	30
LS Range (GHz)	DC - 21.25	DC - 22.0	DC - 23.0	DC - 22.6	DC - 23.0	DC - 25.9	DC - 26.0	DC - 25.0	DC - 24.0	DC - 24.5	DC - 23.5	DC - 23.0
HS Range (GHz)	25.0 - 31.5	25.7 - 30.0	26.75 - 30.0	28.6 - 35.0	29.5 - 41.0	30.0 - 40.0	30.0 - 38.0	30.75 - 34.25	31.0 - 39.0	31.0 - 41.0	31.75 - 42.0	32.0 - 42.0
Dimensions (inches)												
Length	0.450	0.450	0.450	0.260	0.217	0.290	0.550	0.350	0.450	0.217	0.158	0.158
Width	0.140	0.140	0.140	0.120	0.090	0.080	0.140	0.120	0.110	0.090	0.090	0.090
Height	0.088	0.088	0.088	0.079	0.070	0.070	0.083	0.098	0.089	0.070	0.070	0.070
Dimensions (mm)												
Length	11.43	11.43	11.43	6.60	5.50	7.37	13.97	8.89	11.43	5.50	4.01	4.01
Width	3.56	3.56	3.56	3.05	2.29	2.03	3.56	3.05	2.79	2.29	2.29	2.29
Height	2.24	2.24	2.24	2.01	1.78	1.78	2.11	2.49	2.26	1.78	1.78	1.78



Bandpass Filter Ordering Information

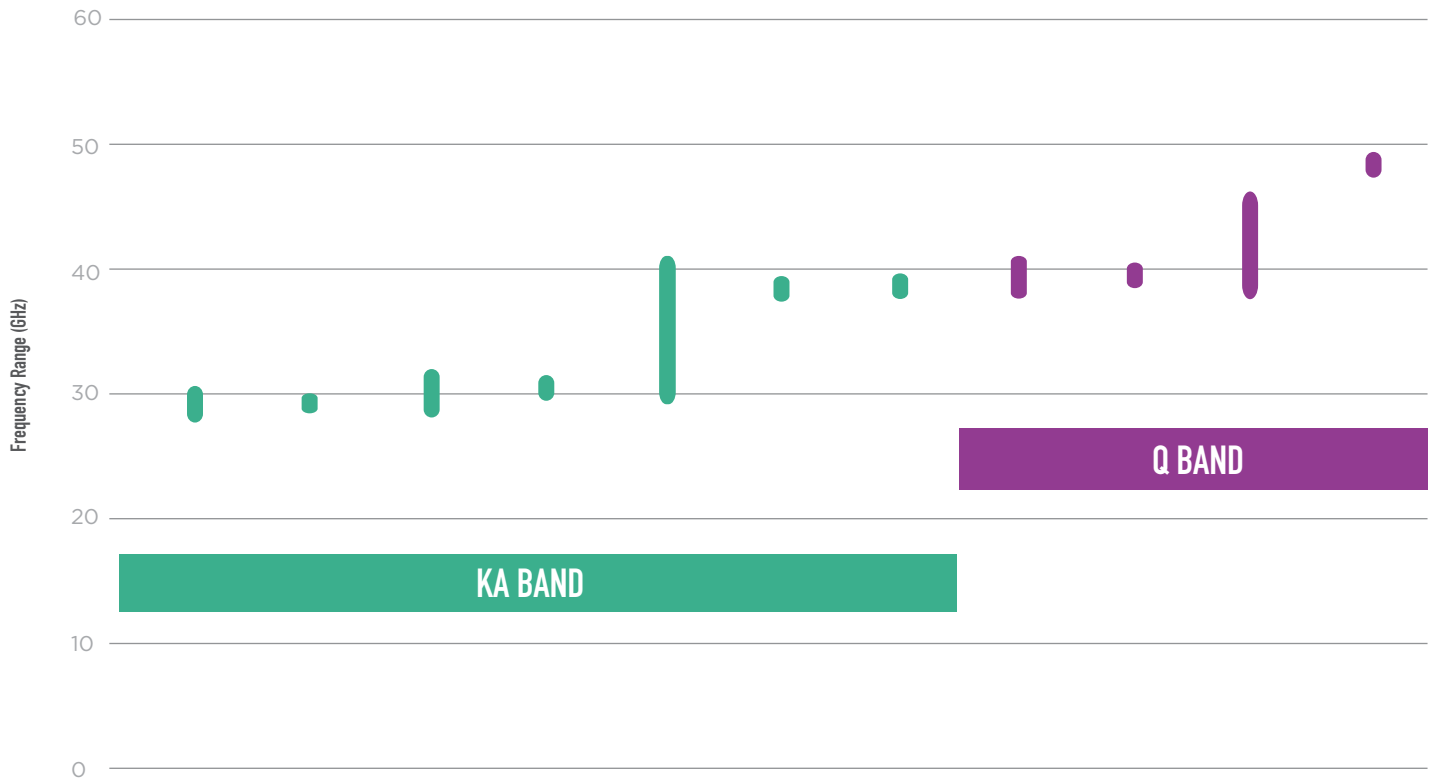

Part Number	B285LB2S	B289KA0S	B291MB0S	B305LA0S	B350NB2S	B380KA1S	B381KD0S	B385MD0S	B393KD0S	B424MB1S	B479KB0S
Center Frequency (GHz)	28.5	28.9	29.25	30.5	35	38	38.1	38.5	39.3	42.5	47.9
Bandwidth (GHz)	2	0.5	3.5	1	10	1	1	3	1.4	4.75	1
Insertion Loss											
@ 25°C (dB)	3.25	4.3	3	4	4.25	4.5	2.5	2.5	2.5	3	4.25
-40°C to +85°C (dB)	3.75	4.8	3.5	4.5	4.75	5	2.75	2.75	2.75	3.5	4.75
VSWR	1.58:1	2.0:1	2.0:1	2.0:1	1.92:1	1.92:1	1.92:1	1.92:1	1.92:1	2.0:1	1.92:1
Rejection											
Amplitude (dB)	40	40	40	40	40	35	40	40	40	30	40
LS Range (GHz)	DC - 25.7	DC - 27.2	DC - 25.25	DC - 28.25	DC - 26.0	DC - 36.0	DC - 35	DC - 34.0	DC - 36	DC - 36.5	DC - 40.0
HS Range (GHz)	31.0 - 40.0	30.6 - 34.0	32.5 - 35.0	32.7 - 38.0	32.5 - 48.0	39.2 - 45.0	43 - 53	44.0 - 56.0	45 - 53	49 - 64	51.5 - 62.0
Dimensions (inches)											
Length	0.330	0.550	0.450	0.550	0.275	0.300	0.275	0.275	0.275	0.236	0.25
Width	0.120	0.140	0.140	0.140	0.080	0.080	0.080	0.080	0.080	0.080	0.08
Height	0.079	0.078	0.088	0.078	0.070	0.074	0.070	0.070	0.070	0.065	0.085
Dimensions (mm)											
Length	8.38	13.97	11.43	13.97	6.99	7.62	6.99	6.99	6.99	5.99	6.35
Width	3.05	3.56	3.56	3.56	2.03	2.03	2.03	2.03	2.03	2.03	2.03
Height	2.01	1.98	2.24	1.98	1.78	1.88	1.78	1.78	1.78	1.65	2.16



Lowpass Filter Selection

Part Number	L050XF9S	L065XG9S	L065XG9W	L095XG9S	L117XH4S	L117XH4W	L128XH4S	L157XG3S
Passband Frequency (GHz)								
3dB Cutoff Frequency	5	6.5	6.5	9.5	11.7	11.7	12.8	15.7
Low	DC	DC	DC	DC	DC	DC	DC	DC
High	4	6	6	9	11	11	12	15
Insertion Loss								
Max @25°C (dB)	1.0	1.3	1.3	1.3	1.0	2.0	1.2	2.2
Dimensions (inches)								
Length	0.220	0.220	0.220	0.220	0.220	0.220	0.220	0.220
Width	0.180	0.180	0.140	0.140	0.140	0.140	0.140	0.140
Height	0.103	0.103	0.118	0.103	0.103	0.113	0.103	0.103
Dimensions (mm)								
Length	5.59	5.59	5.59	5.59	5.59	5.59	5.59	5.59
Width	4.57	4.57	3.56	3.56	3.56	3.56	3.56	3.56
Height	2.62	2.62	3.00	2.62	2.62	2.87	2.62	2.62

Part Number	L157XF3W	L185XF4S	L185XF4W	L204XF4S	L220XH5S	L254XF3S	L288XC3S
Passband Frequency (GHz)							
3dB Cutoff Frequency	17	18.5	18.5	20.4	22	25.4	28.6
Low	DC	DC	DC	DC	DC	DC	DC
High	16.5	18	18	20	22.4	25	27.65
Insertion Loss							
Max @25°C (dB)	2.0	2.2	2.0	1.8	2.5	1.4	2.0
Dimensions (inches)							
Length	0.220	0.220	0.220	0.220	0.220	0.220	0.220
Width	0.140	0.140	0.140	0.140	0.140	0.140	0.140
Height	0.108	0.098	0.113	0.098	0.118	0.098	0.098
Dimensions (mm)							
Length	5.59	5.59	5.59	5.59	5.59	5.59	5.59
Width	3.56	3.56	3.56	3.56	3.56	3.56	3.56
Height	2.74	2.49	2.87	2.49	3.00	2.49	2.49

Highpass Filter Selection

Part Number	H060XHXS	H080XHXS	H100XHXS	H120XHXS	H140XHXS	H160XHXS	H180XHXS	H182XHXS
Passband Frequency (GHz)								
3dB Cutoff Frequency	6	8	10	12	14	16	16.95	18.2
Low	6.5	8.5	10.5	12.5	14.5	16.5	18	18.75
High	20	22	23	30	28	32.5	30	28
Insertion Loss								
Max @25°C (dB)	1	1	1	1	1	1	1	1
Dimensions (inches)								
Length	0.450	0.450	0.450	0.450	0.450	0.450	0.450	0.450
Width	0.200	0.200	0.175	0.175	0.175	0.175	0.175	0.175
Height	0.093	0.093	0.083	0.083	0.083	0.083	0.083	0.083
Dimensions (mm)								
Length	11.43	11.43	11.43	11.43	11.43	11.43	11.43	11.43
Width	5.08	5.08	4.45	4.45	4.45	4.45	4.45	4.45
Height	2.36	2.36	2.11	2.11	2.11	2.11	2.11	2.11



Ceramic Cavity Filters

DLI brand cavity filters utilize proprietary high-Q ceramics to enable miniaturized, highly selective low-loss SMD filters. This design dramatically reduces the part's size, compared to traditional air-filled cavity filters, which makes them a perfect choice for applications with SWAP constraints. These cavity filters enable integration with their small size, shielding and surface mount configuration, achieving repeatable performance without the need for mechanical tuning.



DESIGN ADVANTAGES:

- High quality factor
- 5x Smaller than typical air filled cavities
- True SMD with integrated shielding
- Excellent repeatability without mechanical tuning
- 100% tested and inspected
- Custom designs available
- Narrow bandwidths featured



APPLICATIONS:

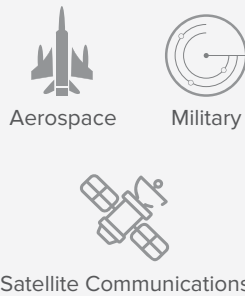

KEY CHARACTERISTICS:

- Low loss in passband: 1-3dB typical
- Devices scalable from C to Ku band
- Bandwidth 0.5-3%

Part Number	C079KB1S	C142KB0S
Center Frequency (GHz)	7.85	14.25
Bandwidth (GHz)	0.15	0.5
Insertion Loss		
@ 25°C (dB)	2.25	2.25
-40°C to +85°C (dB)	2.75	2.75
Return Loss		
@ 25°C (dB)	14	14
Rejection		
Amplitude (dB)	50	50
LS Range (GHz)	DC - 7.25	DC - 12.9
HS Range (GHz)	8.5 - 11.0	16.6 - 19
Dimensions (inches)		
Length	0.937	0.636
Width	0.238	0.238
Height	0.064	0.064
Dimensions (mm)		
Length	23.80	16.15
Width	0.60	6.05
Height	1.63	1.63

TYPICAL CAVITY FILTER TRANSMISSION COEFFICIENT

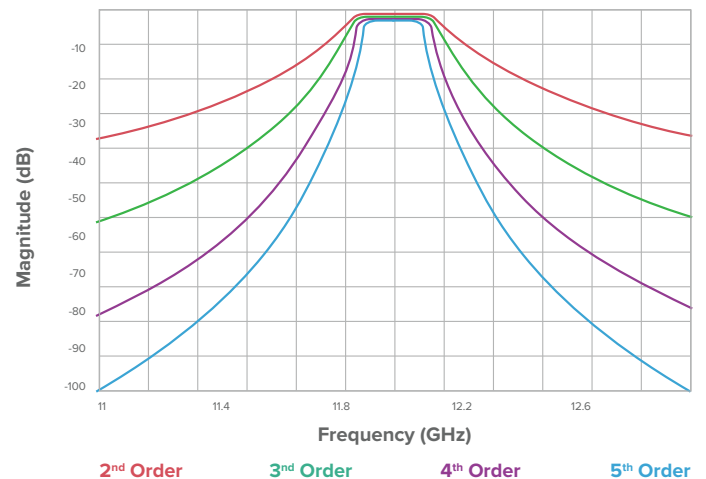

Expanded Offering: Wideband Filters (2-18GHz)

- Integrated wideband solutions for COTS
- Configured for wire-bonding
- Temperature stability -55 to 125°C
- Integrated Quasi-lumped Planar Custom Designs

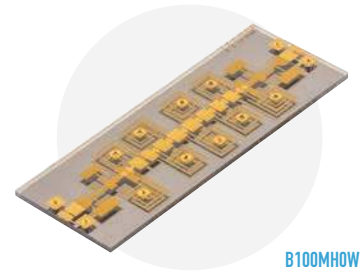

B100MHOW

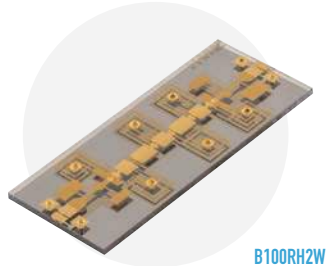

B100RH2W

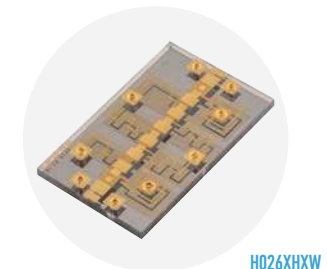

H026XHXW

Part Number	B100MHOW		B100RH2W		H026XHXW	
Parameter	Frequency Range (GHz)	Spec (dB)	Frequency Range (GHz)	Spec (dB)	Frequency Range (GHz)	Spec (dB)
Typical Insertion Loss	2.0 - 3.0	2	2.0 - 18.0	0.7	3.0 - 25.0	0.8
	3.0 - 18.0	0.7				
Typical Return Loss	2.0 - 18.0	15	2.0 - 18.0	12	3.0 - 25.0	12
Minimum Low Side Rejection	DC - 1.20	60	DC - 0.80	60	DC - 1.40	60
	1.20 - 1.30	40	0.80 - 0.90	40	1.40 - 1.70	40
Minimum High Side Rejection	23.0 - 25.0	35	22.0 - 29.0	25		
			29.0 - 35.0	15		
Size (inches) L x W x H	0.420 x 0.160 x 0.010		0.370 x 0.160 x 0.010		0.250 x 0.160 x 0.010	
Size (mm) L x W x H	10.67 x 4.06 x 0.25		9.40 x 4.06 x 0.25		6.35 x 4.06 x 0.25	

Notch Filters

DLI brand notch filters offer attenuation of signals in a specific band, with a compact footprint and extreme repeatability. These are often used in conjunction with a bandpass filter to further attenuate certain frequencies. Contact us for a custom solution for the frequency range you need.

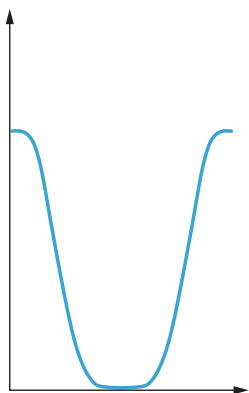

CERTIFICATION:



PART NUMBERS

Part Number	N012ME9S	N016MD9S
Notch Frequency (MHz)	1227	1575
Passbands (MHz)	500-1000 and 1500-2000	DC-1300 and 1800-3000
Passband Insertion Loss (dB)	1.5	1.5
Rejection in Notch (dB)	20	20
Length (in)	0.350	0.250
Width (in)	0.300	0.250
Height (in)	0.103	0.100

Power Dividers



Above: Example of a Wilkinson Power Divider PDW

DLI brand power dividers incorporate low-loss, high-permittivity ceramics, providing miniaturized dimensions and temperature-stable RF performance. The integrated thin film resistors improve phase and amplitude balance over broadband devices. There are two styles: Wilkinson and resistive power dividers, and these designs are configured for attachment with either solder or conductive adhesive. Due to their compact size and proven performance, DLI brand power dividers are a superior option over integration in a soft board material with discrete resistors.



DESIGN ADVANTAGES:

- Small size
- Solder surface mountable
- Excellent repeatability
- Versions available



APPLICATIONS:

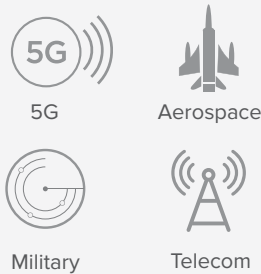

KEY CHARACTERISTICS:

- Low excess insertion loss
- High isolation
- Excellent phase and amplitude balance for Wilkinson Power Dividers only
- Well-matched on all ports

CERTIFICATION:

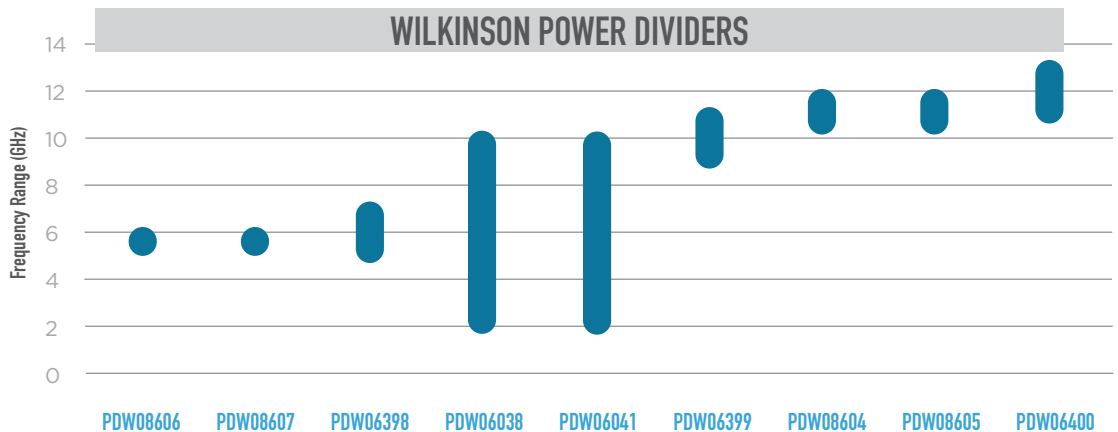

Part Number	PDW08606	PDW08607	PDW06398	PDW06038	PDW06041	PDW06399	PDW08604	PDW08605	PDW06400
Configuration	2:1	4:1	2:1	2:1	2:1	2:1	2:1	4:1	2:1
Nominal Power Splitting	3dB	6dB	3dB	3dB	3dB	3dB	3dB	6dB	3dB
Freq. Low (GHz)	5.3	5.3	5	2	2	9	10.6	10.6	11
Freq. High (GHz)	5.9	5.9	7	10	10	11	11.8	11.8	13
Max. Amplitude Balance (dB)	±0.15	±0.25	±0.20	±0.25	±0.25	±0.1	±0.25	±0.25	±0.25
Max. Phase Balance (degrees)	±2.5	±2.5	±3.0	±5.0	±5.0	±1.0	±1.75	±5.0	±4.0
Typical Excess Insertion Loss (dB)	0.3	0.5	0.25	1.25	1.25	0.4	0.4	0.4	0.5
Typical Return Loss (dB)	20	16	20	20	20	20	15	20	25
Typical Isolation (dB)	20	20	18	20	20	18	15.5	20	20
Mounting	SMD				Chip & Wire	SMD			
Length (inches)	0.115	0.260	0.120	0.400	0.400	0.150	0.085	0.190	0.130
Width (inches)	0.115	0.175	0.240	0.250	0.250	0.100	0.085	0.125	0.130
Height (inches)	0.030	0.030	0.015	0.020	0.020	0.015	0.020	0.020	0.015
Length (mm)	2.921	6.604	3.048	10.16	10.16	3.81	2.159	4.826	3.302
Width (mm)	2.921	4.445	6.096	6.35	6.35	2.54	2.159	3.175	3.302
Height (mm)	0.762	0.762	0.381	0.508	0.508	0.381	0.508	0.508	0.381



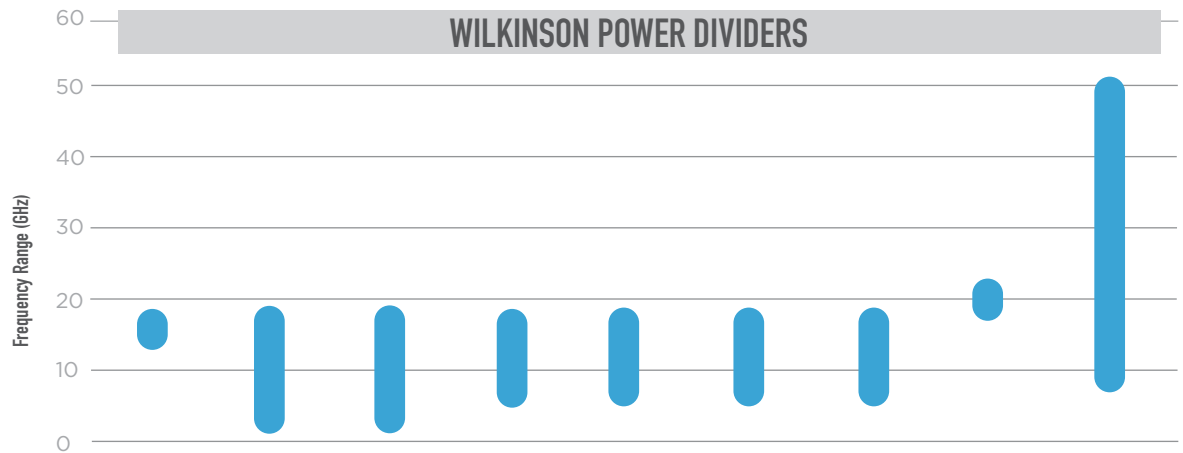

Part Number PDW06401 PDW06407 PDW06933 PDW05758 PDW06011 PDW06089 PDW07948 PDW07691 PDW09692

Configuration	2:1	2:1	2:1	2:1	2:1	4:1	4:1	2:1	2:1
Nominal Power Splitting	3dB	3dB	3dB	3dB	3dB	6dB	6dB	3dB	3dB
Freq. Low (GHz)	15	2	2	6	6	6	6	18	8
Freq. High (GHz)	17	18	18	18	18	18	18	20	50
Max. Amplitude Balance (dB)	±0.1	±0.6	±0.6	±0.5	±0.5	±0.75	±0.75	±0.25	±0.7
Max. Phase Balance (degrees)	±2.0	±8.0	±8.0	±1.25	±1.25	±9.0	±9.0	±1.25	±10
Typical Excess Insertion Loss (dB)	0.25	2.5	2.5	2.35	0.9	0.8	0.8	0.25	0.50
Typical Return Loss (dB)	20	18	18	20	16	15	15	20	17
Typical Isolation (dB)	20	20	20	25	25	20	20	20	20
Mounting	SMD		Chip & Wire	SMD	Chip & Wire	SMD	Chip & Wire	SMD	
Length (inches)	0.120	0.600	0.600	0.185	0.185	0.250	0.250	0.100	0.220
Width (inches)	0.120	0.180	0.180	0.160	0.160	0.300	0.300	0.100	0.080
Height (inches)	0.015	0.020	0.020	0.020	0.020	0.020	0.020	0.015	0.010
Length (mm)	3.048	15.24	15.24	4.699	4.699	6.35	6.35	2.54	5.59
Width (mm)	3.048	4.572	4.572	4.064	4.064	7.62	7.62	2.54	2.03
Height (mm)	0.381	0.508	0.508	0.508	0.508	0.508	0.508	0.381	0.25



Above: Example of a Resistive Power Divider PDR (note: shows mounting configuration on bottom side of the part)

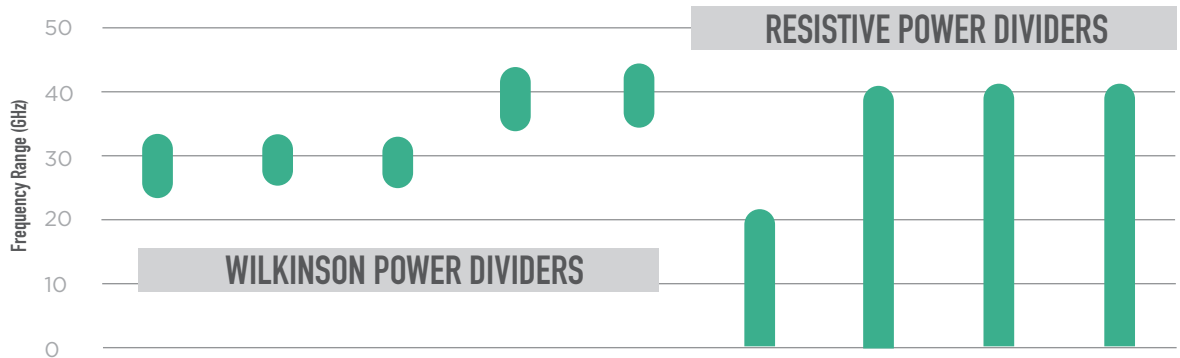

Part Number PDW07069 PDW06984 PDW07630 PDW08323 PDW08324 PDR06390 PDR05848 PDR06120 PDR06380

Configuration	4:1	2:1	2:1	2:1	4:1	2:1	2:1	2:1	2:1	
Nominal Power Splitting	6dB	3dB	3dB	3dB	6dB	6dB	6dB	6dB	6dB	
Freq. Low (GHz)	24	25	25	37	37	0	0	0	0	
Freq. High (GHz)	32	32	32	42	42	20	40	40	40	
Max. Amplitude Balance (dB)	±0.25	±0.25	±0.25	±0.5	±0.75	±0.6	±0.6	±0.6	±0.6	
Max. Phase Balance (degrees)	±5.0	±2.5	±5.0	±5.75	±5.0	±3.0	±3.0	±3.0	±3.0	
Typical Excess Insertion Loss (dB)	1	0.6	0.25	0.75	0.75	0.25	0.5	0.5	0.5	
Typical Return Loss (dB)	15	15	17	15	15	20	20	20	20	
Typical Isolation (dB)	20	15	15	20	25	6	6	6	6	
Mounting	SMD						SMD (AuSn)		Epoxy	SMD
Length (inches)	0.140	0.085	0.070	0.070	0.140	0.075	0.075	0.075	0.075	
Width (inches)	0.170	0.095	0.070	0.070	0.170	0.070	0.065	0.065	0.065	
Height (inches)	0.010	0.010	0.010	0.010	0.010	0.010	0.010	0.010	0.010	
Length (mm)	3.556	2.159	1.778	1.78	3.56	1.91	1.905	1.905	1.905	
Width (mm)	4.318	2.413	1.778	1.78	4.32	1.78	1.651	1.651	1.651	
Height (mm)	0.254	0.254	0.254	0.25	0.25	0.25	0.254	0.254	0.254	



Couplers

The high-frequency directional couplers incorporate DLI's high-permittivity ceramic materials to provide small size and minimal performance variation over temperature.

These couplers offer a turnkey solution in SMD or chip and wire format for high-frequency power monitoring, with the SMD series covering up to 40 GHz.

While custom coupling values are achievable, 3, 10, and 20 dB offerings are available with common footprints for maximum flexibility.

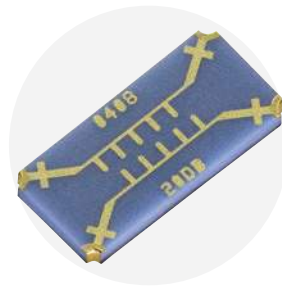

DESIGN ADVANTAGES:

- 30 times smaller than waveguide technology
- 0.8 x 0.2 x 0.03 inch for 10 GHz filter
- Wilkinson

APPLICATIONS:

- Wireless communications modules

KEY CHARACTERISTICS:

- High directivity
- Characteristic impedance: 50Ω
- Multiple PCB feed line configurations
- MSL 1

Expanded Offering!

Quadrature Hybrid Couplers

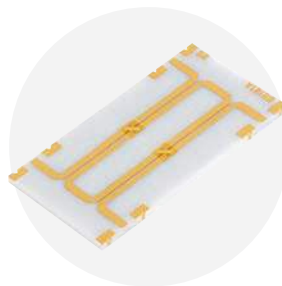

CERTIFICATION:



Part Number	Mounting Type	Frequency (GHz) Low	Frequency (GHz) High	Typical Insertion Loss (dB)	Typical Return Loss (dB)	Isolation (dB)	Amplitude Balance (dB)	Length (in)	Width (in)	Height (in)	Length (mm)	Width (mm)	Height (mm)
FHC09096	SMD	4	8	0.35	20	22	0.4	0.3	0.15	0.01	7.62	3.81	0.254
FHC09097	SMD	4	8	1	16.5	17	0.2	0.7	0.26	0.01	17.78	6.604	0.254
FHC10288	SMD	6	12	1	16.5	17	0.3	0.5	0.25	0.01	12.7	6.35	0.254
FHC10290	SMD	10	20	0.8	16.5	20	0.2	0.3	0.25	0.01	7.62	6.35	0.254
FHC10292	SMD	6	18	1	16.5	20	0.4	0.35	0.25	0.01	8.89	6.35	0.254
FHC09101	Chip and Wire	4	8	0.35	20	22	0.4	0.3	0.15	0.01	7.62	3.81	0.254
FHC09102	Chip and Wire	4	8	1	16.5	17	0.2	0.7	0.25	0.01	17.78	6.35	0.254
FHC10289	Chip and Wire	6	12	1	16.5	17	0.2	0.5	0.25	0.01	12.7	6.35	0.254
FHC10291	Chip and Wire	10	20	0.8	16.5	20	0.2	0.3	0.25	0.01	7.62	6.35	0.254
FHC10293	Chip and Wire	6	18	1	16.5	20	0.4	0.35	0.25	0.01	8.89	6.35	0.254

Typically 90 degree phase balance ± 3



COUPLERS

Part Number	F _L (GHz)	F _H (GHz)	Coupling (dB)	Passband Coupling Variation Typ. (dB)	Excess Insertion Loss Typ. (dB)	Return Loss Typ. (dB)	Isolation Typ. (dB)	Directivity Typ. (dB)	Mounting Type	Length (in)	Width (in)	Height (in)	Length (mm)	Width (mm)	Height (mm)
FPC06700	5.9	6.5	3	±1	0.75	17	20	17	SMD	0.425	0.250	0.020	10.80	6.35	0.51
FPC06630	9	11	3	±1	0.5	20	18	15	SMD	0.286	0.180	0.015	7.26	4.57	0.38
FPC10207	8	12	3	1	0.4	20	20	17	SMD	0.350	0.170	0.015	8.90	4.32	0.38
FPC06701	10.7	12.75	3	±1	0.5	12	15	12	SMD	0.255	0.155	0.015	6.48	3.94	0.38
FPC07183	24	33	3	1	1	12	15	12	SMD	0.180	0.110	0.010	4.57	2.79	0.25
FPC07234	2	18	10	±1.5	0.8	12	20	10	SMD	0.500	0.150	0.030	12.70	3.81	0.76
FPC09291	2	18	10	±1.5	0.8	12	20	10	Chip and Wire	0.500	0.150	0.030	12.70	3.81	0.76
FPC06073	4	8	10	±0.75	0.3	20	32	22	SMD	0.170	0.080	0.015	4.32	2.03	0.38
FPC06149	4	8	10	±0.75	0.5	15	30	20	Chip and Wire	0.180	0.080	0.015	4.57	2.03	0.38
FPC06719	6	18	10	±1.0	0.5	15	23	13	SMD	0.255	0.100	0.015	6.48	2.54	0.38
FPC07643	6	18	10	±1.0	0.5	15	23	13	Chip and Wire	0.255	0.100	0.015	6.48	2.54	0.38
FPC06074	8	12	10	±0.2	0.5	20	30	20	SMD	0.120	0.080	0.015	3.05	2.03	0.38
FPC06150	8	12	10	±1.5	1	12	24	14	Chip and Wire	0.130	0.090	0.015	3.30	2.29	0.38
FPC06075	12	18	10	±1.25	0.3	15	25	14	SMD	0.100	0.080	0.015	2.54	2.03	0.38
FPC06151	12	18	10	±0.75	0.75	15	20	10	Chip and Wire	0.100	0.080	0.015	2.54	2.03	0.38
FPC07182	20	40	10	±1.5	0.3	10	23	13	SMD	0.065	0.050	0.010	1.65	1.27	0.25
FPC07180	2	18	20	±1.0	1	15	25	5	SMD	0.500	0.150	0.015	12.70	3.81	0.38
FPC06076	4	8	20	±2.5	0.75	20	35	15	SMD	0.170	0.080	0.015	4.32	2.03	0.38
FPC06152	4	8	20	±1.5	0.25	25	40	20	Chip and Wire	0.180	0.080	0.015	4.57	2.03	0.38
FPC06913	6	18	20	±1.0	0.3	18	30	10	SMD	0.180	0.110	0.015	4.57	2.79	0.38
FPC07337	6	18	20	±1	0.7	15	25	5	Chip and Wire	0.180	0.100	0.015	4.57	2.54	0.38
FPC06153	8	12	20	±1.25	0.2	20	35	15	Chip and Wire	0.130	0.090	0.015	3.30	2.29	0.38
FPC06302	8	12	20	±1.25	1	20	35	15	SMD	0.120	0.080	0.015	3.05	2.03	0.38
FPC06078	12	18	20	±0.75	0.3	23	35	15	SMD	0.100	0.080	0.015	2.54	2.03	0.38
FPC06154	12	18	20	±1.5	0.3	10	30	10	Chip and Wire	0.100	0.080	0.015	2.54	2.03	0.38
FPC07181	20	40	20	±1.5	0.3	12	30	10	SMD	0.065	0.050	0.010	1.65	1.27	0.25
FPC06077	8	12	25	±1.0	0.3	18	35	10	SMD	0.120	0.080	0.015	3.05	2.03	0.38

RESISTIVE COUPLERS

Part Number	F _L (GHz)	F _H (GHz)	Coupling (dB)	Passband Coupling Variation Typ. (dB)	Excess Insertion Loss Typ. (dB)	Return Loss Typ. (dB)	Mounting Type	Length (in)	Width (in)	Height (in)	Length (mm)	Width (mm)	Height (mm)
FPC06881	0	25	20	±1.5	2.85	12	SMD	0.060	0.088	0.010	1.52	2.24	0.25
FPC07803	0	40	20	±2	3	12	SMD	0.060	0.088	0.010	1.52	2.24	0.25
FPC06882	0	25	30	±3	2	12	SMD	0.060	0.088	0.010	1.52	2.24	0.25
FPC07802	0	40	30	±2	2.5	12	SMD	0.060	0.088	0.010	1.52	2.24	0.25

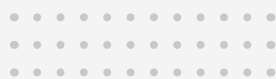

Integrated R-C Networks

BIAS FILTER NETWORK

Knowles Precision Devices takes advantage of the high permittivity ceramics offered by the DLI brand combined with thin film resistors to provide Unique Bias Filter products. Bias Filter Networks provide high attenuation (>40dB, 300 MHz to 40 GHz) of unwanted RF signals on DC Bias lines. They are designed for applications with low current, such as gate bias of an FET or MMIC. RF energy is bypassed to RF ground. Bias Filters are designed for conductive epoxy attachment directly to the Ground plane (module floor) of Chip & wire modules. DC current rating: 10 mA max.

EQUIVALENT SCHEMATIC REPRESENTATION:

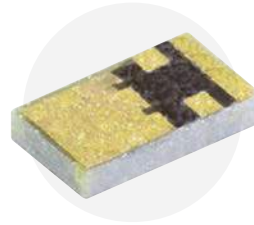
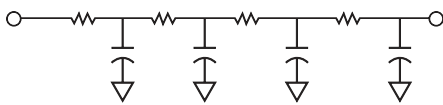

PART NUMBERS

Full PN	Cap Range (pF)	Resist	Width (in)	Length (in)	Thickness (in)
B20BHSBN01	40 to 90	100 ± 20%	.020 ± .001	.034 ± .001	.006 ± .001
B20BLSBN01	40 to 90	100 ± 20%	.020 ± .001	.034 ± .001	.006 ± .001
B28BHBFN01	76 to 171	600 ± 20%	.028 ± .001	.053 ± .001	.007 ± .001

SELF BIAS NETWORK

Knowles Precision Devices takes advantage of the high-permittivity ceramics offered by the DLI brand combined with thin film resistors to provide a device that integrates source decoupling and user-selectable bias resistance.

The technique is commonly referred to as a self-bias GaAs FET amplifier – this enables the use of a single DC supply voltage. The gate is at DC ground potential and a negative Vgs is provided by the voltage drop across the selected wire-bond resistors from source to ground – thus setting the desired drain bias current (IDS).

The chip network is designed for epoxy attachment to a ground Ridge, one on either side of an FET chip transistor. This provides symmetric, minimum reactance to ground source bypassing for optimum FET gain. By selectively wire bonding from resistor pads to ground, the pair of networks used for each FET provides a wide range of Resistance combinations. The Self Bias Networks, used as a pair, replace 2 standard Parallel plate capacitors and a separate set of bias resistors, reducing parts count, assembly and size.

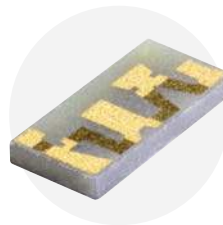

EQUIVALENT SCHEMATIC REPRESENTATION:

User wire bond to Ground to select resistance.

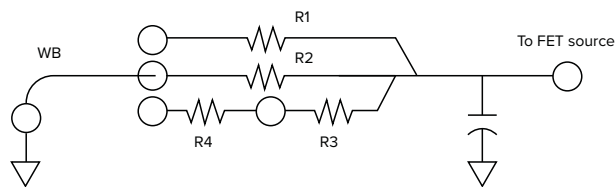

Resistor Values:

R1 - 200Ω R3 - 50Ω
R2 - 100Ω R4 - 20Ω

Nominal Capacitance:

50pF

PART NUMBERS

Full PN	Cap Range (pF)	Resist	Width (in)	Length (in)	Thickness (in)
B28BJBFN01	76 to 171	600 ± 20%	.028 ± .001	.053 ± .001	.007 ± .001
B28BTBFN01	112 to 168	600 ± 20%	.028 ± .001	.053 ± .001	.007 ± .001

CUSTOM INTEGRATED PASSIVE DEVICES

Reach our to our team of engineers to inquire about custom designs at: DLIengineering@knowles.com

TYPICAL APPLICATIONS

- Wireless communication modules
- Ideal varactor decoupling element
- High gain RF/Microwave modules
- Ideal GaAs FET gate biasing device
- MMIC multichip modules
- MIC broadband high gain RF/Microwave modules
- Bias line voltage divider and integrated decoupling capacitor

CERTIFICATION:



Integrated R-C Networks

C-R-C DECOUPLING NETWORKS (aka. RF Blocking Networks)

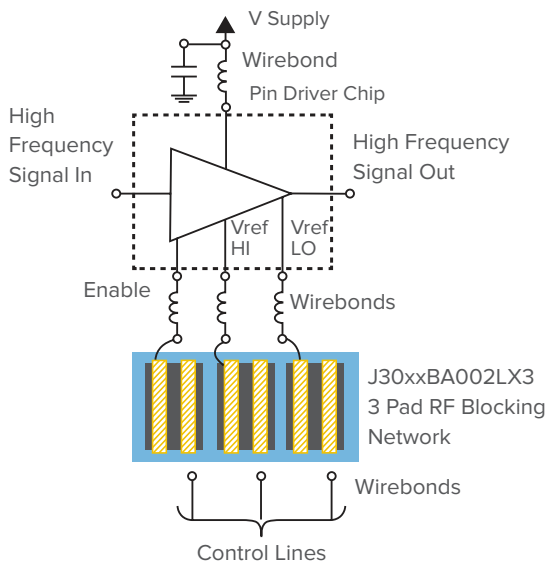

SEGMENT EQUIVALENT SCHEMATIC REPRESENTATION

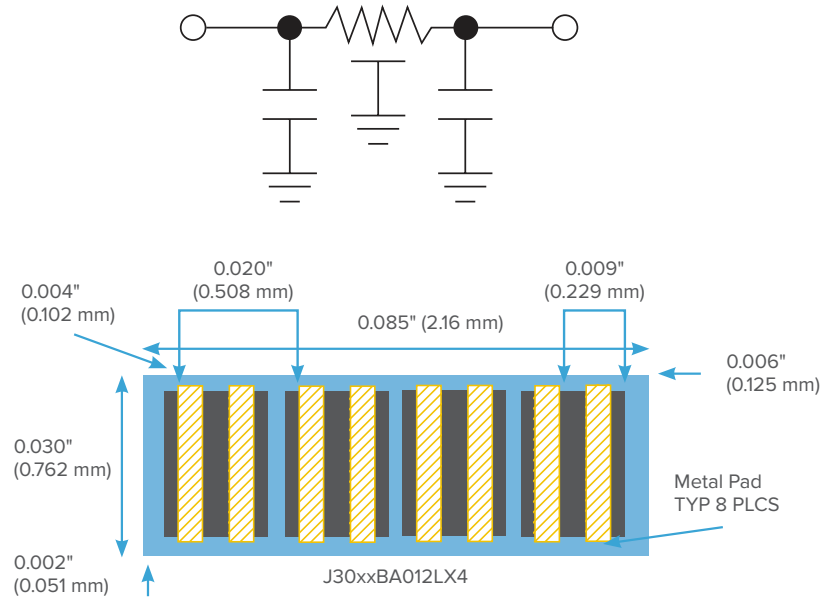

Part Number J30BLBA032LX1 J30BLBA022LX2 J30BLBA002LX3 J30BLBA012LX4 J30BJBA032LX1 J30BJBA022LX2 J30BJBA002LX3 J30BJBA012LX4

Number of RC Segments	1	2	3	4	1	2	3	4
Nominal Resistance (pad to pad) (Ω)	10	10	10	10	10	10	10	10
Capacitance (typical) (μF)	30	30	30	30	45	45	45	45
Maximum DF	3.00%	3.00%	3.00%	3.00%	3.00%	3.00%	3.00%	3.00%
TCC	X7R	X7R	X7R	X7R	X7R	X7R	X7R	X7R
Rated Voltage (Vdc)	25	25	25	25	25	25	25	25
Attachment Method	All are configured for Chip & Wire attachment							
Termination Finish	100 μ inches Au, minimum							
Dimensions (inches)								
Length	0.025	0.045	0.065	0.085	0.250	0.045	0.065	0.085
Width	0.030	0.030	0.030	0.030	0.030	0.030	0.030	0.030
Dimensions (mm)								
Length	0.64	1.14	1.65	2.16	6.35	1.14	1.65	2.16
Width	0.76	0.76	0.76	0.76	0.76	0.76	0.76	0.76



Gain Equalizers

The DLI brand of gain equalizers are designed to compensate for module gain slope. Excellent repeatable microwave performance is achieved by application of precision thin-film fabrication and high-permittivity ceramic materials. This unique design solution provides near ideal R-C frequency response that is far superior to “stacked R-C chip” assemblies.



DESIGN ADVANTAGES:

- Many designs smaller than 0402 case size
- Ease of integration
- Customization available



APPLICATIONS:

- Broadband Microwave modules: EW, ECM, ECCM
- Equalizer is utilized as a compensation circuit to correct for loss slope created by other circuit elements such as amplifiers



KEY CHARACTERISTICS:

- Superior microwave performance
- Reduced cost
- Flatten amplifier gain response
- Positive gain slope

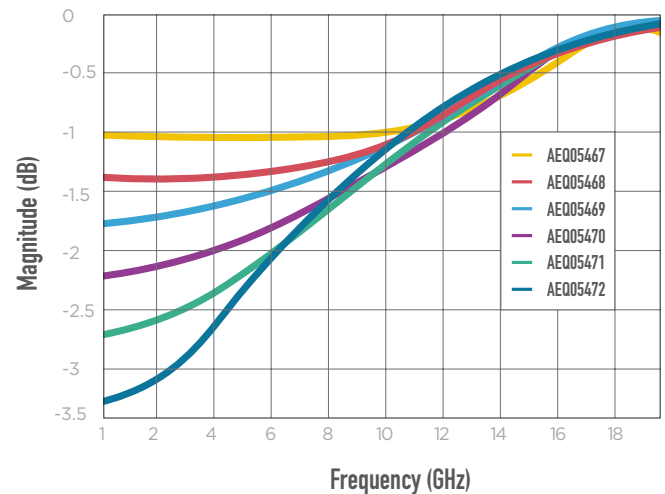
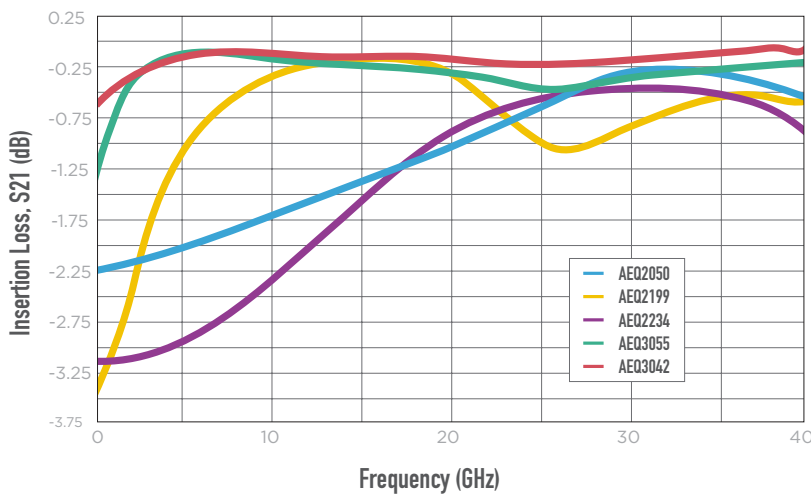

CERTIFICATION:



GAIN EQUALIZERS

Epoxy	Solderable	Nominal Slope	Lp	Wp	G	Length	Width	Thickness
AEQ2050 ^[1]	AEQ05510 ^[2]	2.25 dB	9	14	8	30	18	5
AEQ2199 ^[1]	AEQ05246 ^[2]	3.5 dB	7		12	28	16	7
AEQ2234 ^[1]	AEQ06042 ^[2]	3.25 dB	8	12		32		5
AEQ3042 ^[3]	AEQ3042 ^[3]	0.6 dB	17.5	17.5	3	40	20	6
AEQ3055 ^[3]	AEQ3055 ^[3]	1.5 dB	15.4	18.4	7.2			
AEQ05467 ^[4]	AEQ05467 ^[4]	1.0 dB	7 min	14	10	28	16	7
AEQ05468 ^[4]	AEQ05468 ^[4]	1.5 dB						
AEQ05469 ^[4]	AEQ05469 ^[4]	2.0 dB						
AEQ05470 ^[4]	AEQ05470 ^[4]	2.5 dB						
AEQ05471 ^[4]	AEQ05471 ^[4]	3.0 dB						
AEQ05472 ^[4]	AEQ05472 ^[4]	3.5 dB						

ALL DIMENSIONS IN MILS. Operational Temperature Range: - 55 C to + 125 C

METALLIZATIONS AS NOTED IN TABLE REFERENCES ABOVE

	TOP	MOUNTING SURFACE
1	<ul style="list-style-type: none"> 100 Microinches Min. Au Over 400 ± 100 Angstroms Min. TiW 	<ul style="list-style-type: none"> 100 Microinches Min. Au Over 400 ± 100 Angstroms Min. TiW Over TaN Resistor Layer
2	<ul style="list-style-type: none"> 100 Microinches Min. Au Over 50 Microinches Min. NiV Over 300 Angstroms Min. TiW 	<ul style="list-style-type: none"> 25 Microinches Min. Au Over 50 Microinches Min. NiV Over 5 Microinches Min. Au Over 300 Angstroms Min. TiW Over TaN Resistor Layer
3	<ul style="list-style-type: none"> 50 Microinches Min. Au Over 400 +/- 100 Angstroms Min. TiW 	<ul style="list-style-type: none"> 20 Microinches Min. Au Over 30 Microinches Min. Ni Over 50 Microinches Min. Au Over 400 +/- 100 Angstroms Min. TiW Over TaN Resistor Layer
4	<ul style="list-style-type: none"> 15 Microinches Min. Au Over 50 Microinches Min. NiV Over 300 Angstroms Min. TiW 	<ul style="list-style-type: none"> 15 Microinches Min. Au Over 50 Microinches Min. NiV Over 300 Angstroms Min. TiW Over TaN Resistor Layer

PHYSICAL DIMENSIONS

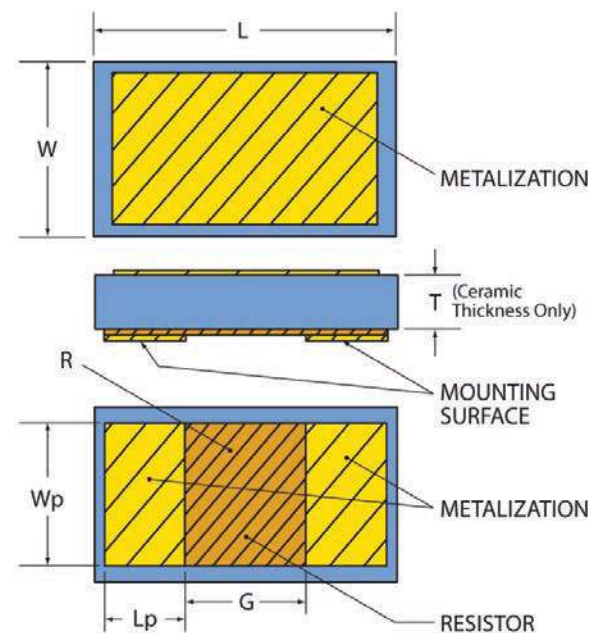

MMWAVE FILTERS:

Addressing the Challenges Presented by 5G

Based on decades of experience working with mmWave filtering solutions, Knowles Precision Devices has a product line of **mmWave filter solutions** based on DLI filter technology that addresses the challenges outlined below of working with 5G technology.

SHRINKING WAVELENGTHS

At 700MHz, the wavelength in free space is about 430mm, and at 2.6GHz, wavelengths are 115mm. Yet at 39GHz, wavelengths are only 7.7mm.

REDUCED SIZE OF RF FRONT END

As wavelength shrinks so do antenna sizes, and for arrays to avoid diffraction effects, antenna spacing needs to be similarly shrunk. Filters in RF front ends need to be compact.

INCREASE IN NUMBER OF PATHS IN RF FRONT END

The enabling technologies for mmWave, beam steering and massive MIMO, rely on arrays of antenna elements, which, in turn, rely on multiple RF paths per antenna element — further necessitating compact filtering components.

INCREASED TEMPERATURE

In dense board environments temperatures rise, and RF front ends need to operate at increased temperature and with inherent temperature stability.

INCREASED NEED FOR REPEATABLE PERFORMANCE

High-frequency circuits are sensitive to variations in performance from part to part. Repeatability in filter component performance is key to avoid costly "set-at-test" scenarios.

EVER-PRESENT NEED TO PERFORM

Filter components for mmWave RF front ends need to encompass all these factors, and they still need to perform to ensure the best spectral efficiency and rejection possible.

Using specialized topologies and material formulations, Knowles Precision Devices created off-the-shelf catalog designs available up to 42 GHz that are 20 times smaller than the current alternatives.

MMWAVE FILTER KEY FEATURES & BENEFITS:

- Filter size reduction of up to 20x
- Stable operation from -55°C to +125°C
- Precise manufacturing means no tuning
- Performance—very broad band, high rejection and low insertion loss



Specialty Kits

GAIN EQUALIZER KIT

Our Gain Equalizers offer gain slope compensation in a single component.

Benefits include:

- Superior microwave performance
- Excellent repeatability
- Ease of assembly
- Custom designs
- Small size (0402 or smaller)
- Products up through 40GHz



EW GAIN EQUALIZER KIT

Benefits include:

- Superior microwave performance
- Excellent repeatability
- Ease of assembly
- Custom designs
- Small size (0302)
- Designed for 2-18GHz application



	AEQ02050	AEQ02199	AEQ02234	AEQ03055	AEQ03042
Low Freq. Loss	2.2dB	3.0dB	3.5dB	1.6dB	0.8dB
Min. Loss Freq.	31.0GHz	15.0GHz	27.0GHz	5.0GHz	5.0GHz
Mounting Method	Epoxy	Epoxy	Epoxy	Solder	Solder

	AEQ05467	AEQ05468	AEQ05469	AEQ05470	AEQ05471	AEQ05472
Low Freq. Loss	1.0dB	1.35dB	1.75dB	2.25dB	2.75dB	3.25dB
Min. Loss Freq.	18GHz	18GHz	18GHz	18GHz	18GHz	18GHz
Mounting Method	Solder/ Epoxy	Solder/ Epoxy	Solder/ Epoxy	Solder/ Epoxy	Solder/ Epoxy	Solder/ Epoxy

5G Kit 26GHz - B259MC1S

	PART NUMBER	TYPE	FC (GHz)	FL (GHz)	FH (GHz)	INSERTION LOSS (@FC, dB 25°C)	L. INCHES (mm)	W. INCHES (mm)	H. INCHES (mm)
5G Kit, 26GHz, n258	B259MC1S	26GHz Bandpass	25.9	24.25	27.5	3.5	0.2165 (5.4991)	0.090 (2.286)	0.070 (1.778)
	DEB-B259MC1S	26GHz Bandpass, mounted on eval board	25.9	24.25	27.5	3.5			
	B274MB1S	28GHz Bandpass	28	25	29.5	3.25	0.450 (11.43)	0.110 (2.794)	0.089 (2.2606)
	B280LB0S	28GHz Bandpass	28	27	29	1.5	0.350 (8.89)	0.120 (3.048)	0.098 (2.4892)
	B280LA0S	28GHz Bandpass	28	27.5	28.5	4	0.550 (13.97)	0.140 (3.556)	0.083 (2.1082)
	FPC07182	20dB Coupler		20	40	0.3	0.065 (1.651)	0.050 (1.27)	0.010 (0.254)
	FPC07181	10dB Coupler		20	40	0.6	0.065 (1.651)	0.050 (1.27)	0.010 (0.254)
	PDW07069	4-way Power Divider		25	32	1	0.140 (3.556)	0.170 (4.318)	0.010 (0.254)
	PDW07630	2-way Power Divider		25	32	0.25	0.070 (1.778)	0.070 (1.778)	0.010 (0.254)

5G Kit 28GHz - B274MB1S

	PART NUMBER	TYPE	FC (GHz)	FL (GHz)	FH (GHz)	INSERTION LOSS (@FC, dB 25°C)	L. INCHES (mm)	W. INCHES (mm)	H. INCHES (mm)
5G Kit, 28GHz, n257, n261	B274MB1S	28GHz Bandpass	28	26.5	29.5	3.25	0.450 (11.43)	0.110 (2.794)	0.089 (2.2606)
	DEB-B274MB1S	28GHz Bandpass, mounted on eval board	28	26.5	29.5	3.25			
	B280LB0S	28GHz Bandpass	28	27	29	1.5	0.350 (8.89)	0.120 (3.048)	0.098 (2.4892)
	B280LA0S	28GHz Bandpass	28	27.5	28.5	4	0.550 (13.97)	0.140 (3.556)	0.083 (2.1082)
	PDW07069	4-way Power Divider		25	32	1	0.140 (3.556)	0.170 (4.318)	0.010 (0.254)
	PDW07630	2-way Power Divider		25	32	0.25	0.070 (1.778)	0.070 (1.778)	0.010 (0.254)
	FPC07182	20dB Coupler		20	40	0.3	0.065 (1.651)	0.050 (1.27)	0.010 (0.254)
	FPC07181	10dB Coupler		20	40	0.6	0.065 (1.651)	0.050 (1.27)	0.010 (0.254)

5G Kit 39GHz - B385MD0S

	PART NUMBER	TYPE	FC (GHz)	FL (GHz)	FH (GHz)	INSERTION LOSS (@FC, dB 25°C)	L. INCHES (mm)	W. INCHES (mm)	H. INCHES (mm)
5G Kit, 39GHz, n260	B385MD0S	39GHz Bandpass	38.5	37	40	2.5	0.275 (6.985)	0.080 (2.032)	0.075 (1.905)
	DEB-B385MD0S	39GHz Bandpass, mounted on eval board	38.5	37	40	2.5			
	PDW08323	2-way Power Divider		37	42	0.5	0.070 (1.778)	0.070 (1.778)	0.010 (0.254)
	PDW08324	4-way Power Divider		37	42	0.7	0.170 (4.318)	0.140 (3.556)	0.010 (0.254)
	FPC07182	20dB Coupler		20	40	0.3	0.065 (1.651)	0.050 (1.27)	0.010 (0.254)
	FPC07181	10dB Coupler		20	40	0.6	0.065 (1.651)	0.050 (1.27)	0.010 (0.254)

Additional Product Information Right at Your Fingertips

Online product guides and e-Books provide a wealth of knowledge to assist in the ordering process.

Knowles' Microwave Products Guide

This document is the technical complement to the Microwave Products Catalog. It provides detailed information on the configuration of DLI devices and what you need to know about board design, stencil design, assembly and testing to achieve the best outcomes using these devices.



Scan the QR code to view the [Microwave Products Guide](#)



Knowles' Build-to-Print e-Book



Visit info.knowlesc capacitors.com/build-to-print-basics to download the e-Book and with an overview of Knowles' capabilities and options for build-to-print services.

Knowles' RF Filters e-Book

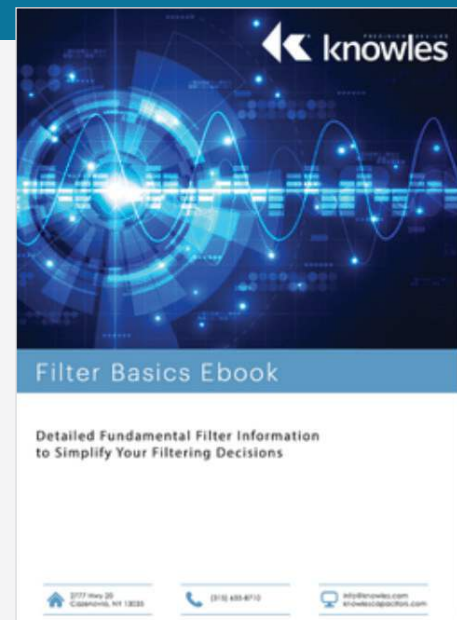

Visit info.knowlesc capacitors.com/filter-basics-ebook to download the e-Book for an overview of the basics of RF Filters and performance assessment.



IMC Brand Filter Configurations

CUSTOM WORK YOU CAN COUNT ON

Our engineers have the knowledge and expertise to create custom work to fit your business needs, which includes:

- Creating new solutions designed to your exact specifications.
- Recreating product from old designs - nothing is obsolete to us!
- We never expire designs, we have an extensive archive.
- Creating second source designs from existing solutions.
- No size limit - any numbers of sections can be ordered.

Below is just a sampling of the various configurations available for Coaxial Ceramic, Lumped Element and Cavity Filters.

PC BOARD MOUNT

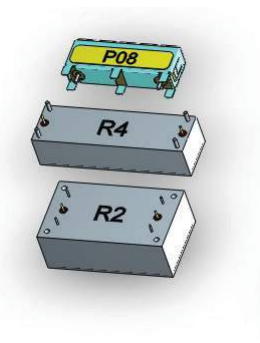

CONNECTORIZED

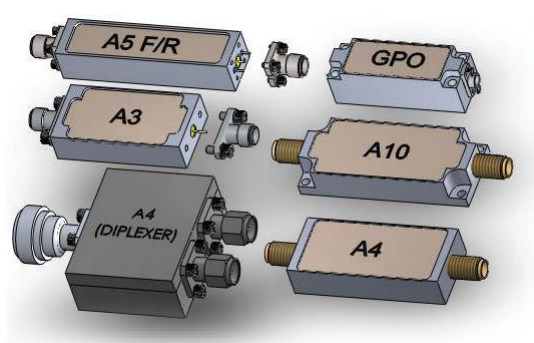

AVAILABLE CONNECTORS INCLUDE BUT ARE NOT LIMITED TO:

SMA-F	SMA-M
SSMA-F	SSMA-M
SMB-F	SMB-M
SSMB-F	SSMB-M
SMC-F	SMC-M
TNC-F	TNC-M
Type N-F	Type N-M
BNC-F	BNC-M
GPO-F	GPO-M
QMA-F	
mmcx-F	

SURFACE MOUNT

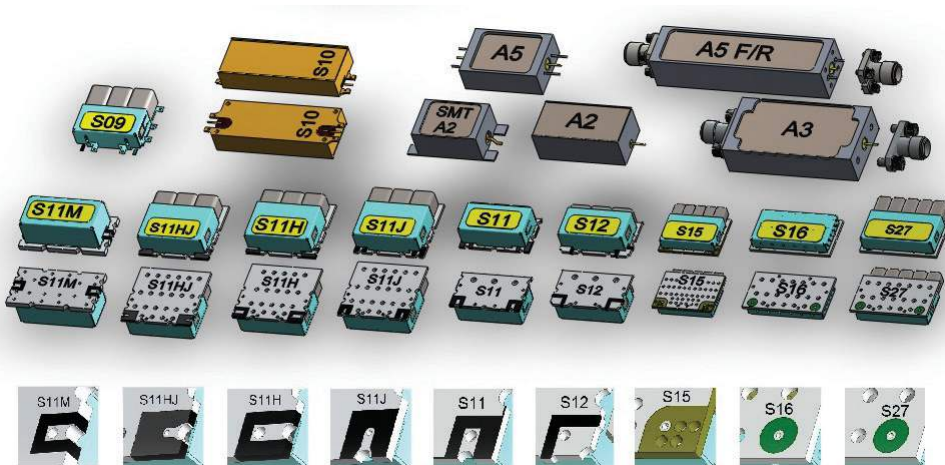

Reach out to our engineers for assistance with custom designs at:
DLengineering@knowles.com

DLI Brand Devices: Available Configurations

Optimal performance relies on having optimal assembly, especially with increasing frequencies. DLI offers devices with the following configurations, to fit applications focused on the highest rejection (WB), or optimized for volume manufacturing (SMD). See the general descriptions as follows:

WIREBOND TERMINATION

Chip and Wire or Wirebond (WB): For detailed recommendations reference Wire Bond Application Note*

- Typically mounted to board with conductive epoxy for grounding (not solderable finish unless specified)
- IO connections are wire- or ribbon-bonded
- Customer will design necessary RF shielding or channelization into application
- Board and housing materials should be chosen with the aim to minimize CTE mismatch with the ceramic filter
- Termination finish: Gold
- Filter PN designates W for last character

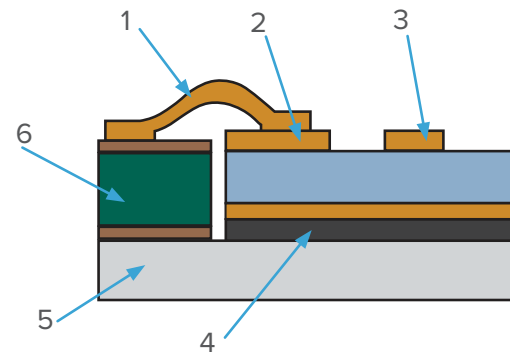

WIREBOND (WB) CALLOUTS

- | | |
|--|--|
| 1. Wire/ribbon signal bond | 4. Conductive epoxy mount (ground pad) |
| 2. Signal pad on part (Au termination) | 5. Housing floor |
| 3. RF pattern | 6. PCB with cavity for part |

SURFACE MOUNT (SMD) TERMINATION

Surface mount (SMD): For detailed recommendations, reference the Microwave Products Guide

- Typically mounted during reflow soldering with solder paste
- IO connections and ground pad are soldered using solder paste
- Most SMD devices include integrated shielding if needed (unless specified)
- Termination finish: ENIG
- Filter PN designates S for last character

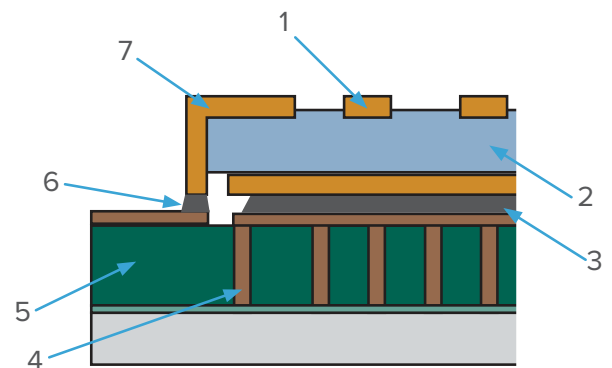

SURFACE MOUNT (SMD) CALLOUTS

- | | |
|-----------------------------------|--------------------------------|
| 1. RF pattern (non-solderable) | 4. PCB vias in pad |
| 2. Ceramic substrate | 5. Printed circuit board (PCB) |
| 3. Solder attachment (ground pad) | 6. Solder attachment (IO) |
| | 7. IO castellation (ENIG) |



*To view the Wire Bond Application Note scan the QR Code



DLI Brand Devices

STORAGE AND HANDLING FAQs

- Materials Declarations, Certifications, Conflict Minerals Statements, RoHS and REACH Statements available online at www.knowlescapacitors.com/Quality
- All DLI brand devices are Moisture Sensitivity Level (MSL)=1
 - Per IPC/JEDEC J-STD-020D
- All DLI brand devices fall under Group 1 – Fungus Inert Materials
 - Per MIL-STD-820; Paragraph 508.8
- All DLI brand devices are not ESD sensitive (passive devices)
 - Note: DLI packaging is ESD sensitive to make sure it is safe for ESD sensitive manufacturing environments, even if the parts themselves are not sensitive.
- Tape and Reel or Bulk Packaged Storage Temperature: up to 40°C (cool, dry storage is preferred)
- Part Storage (Pre-Assembly): -55 to 125°C
- Post-assembly Storage and Operating Temperature Range: -55 to 125°C
- No concern for outgassing, all materials compliant as follows:
 - Ceramic
 - Metallization
 - Cover
 - Solder
 - Solder Dam

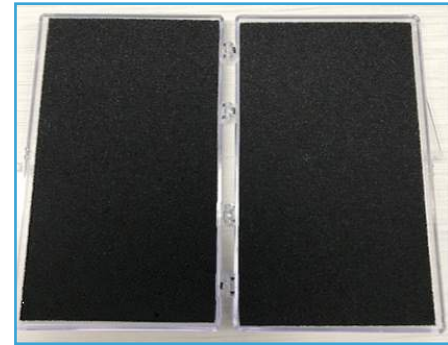

Packaging Types:

- Tape and Reel
- Bulk Cases (shown above)
- Waffle Packs

RF TESTING AND SHIELDING

- Knowles has precision measurement capability up to 67GHz, utilizing multiple vector network analyzers
- Filters are probed with coplanar RF probes (ground signal ground (GSG)) with 450 or 750 micron pitch, depending on operating frequency and configuration, on the bottom side of the filter
- When using coplanar RF probes, it is critical that all 3 points of the probe are equally in contact with the device for an accurate reading
- When devices do not include integrated shielding, custom fixtures are employed to assure accurate measurements without outside noise
- Shielding and customer housing dimensions are critical to account for during the design phase for continuity between filter modeling, measured data and actual use environments (contact DLEngineering@knowles.com if you are not sure your shielding solution aligns with the device design)

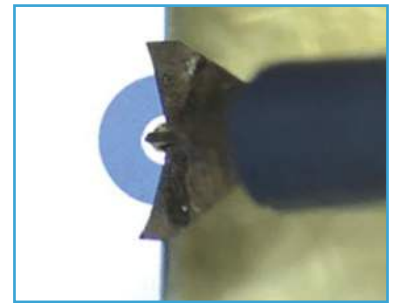

Top: Coplanar RF probe example
Bottom: Example of test fixture

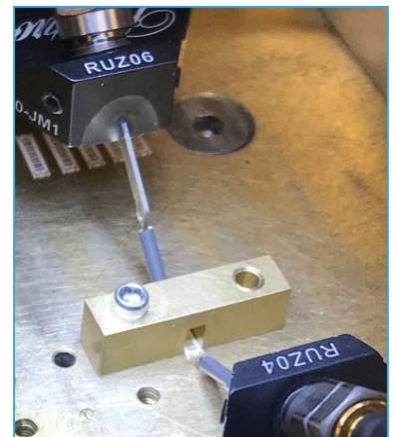

RoHS Compliance Statement

Knowles Precision Devices is a leading supplier to the electronic components market and is fully committed to offering products supporting Restriction of Hazardous Substances (RoHS) directives. All our dielectric formulations are RoHS compliant along with a broad range of capacitors with RoHS compliant terminations. Knowles Precision Devices complies with the requirements of the individual customer and will maintain product offerings that meet industry demands.

Quality and Environmental Policy

Knowles Precision Devices' reputation for quality and environmental responsibility is based on a commitment not only to meet customer requirements, but to exceed their expectations. The entire organization, beginning with top management, strives to achieve excellence in designing, manufacturing and delivering High Q capacitors and proprietary thin film components for niche high-frequency applications, while maintaining safe and healthy working conditions.

Furthermore, Knowles Precision Devices is committed to achieving these goals in an environmentally responsible manner through a commitment to comply with environmental regulations and pollution prevention initiatives. Knowles Precision Devices strives to continually improve the effectiveness of its quality and environmental management system through the establishment and monitoring of objectives and targets.

Microwave products proudly made in the USA.



For more information, visit us online at www.knowlescapacitors.com

05232023/R8



Scan the QR code to view our Blog!