

POSITIONS/ CONTACTS	A		B	
	INCH	MM	INCH	MM
02/02	0.100	2.54	0.216	5.48
03/03	0.200	5.08	0.316	8.02
04/04	0.300	7.62	0.416	10.56
05/05	0.400	10.16	0.516	13.10
06/06	0.500	12.70	0.616	15.64
07/07	0.600	15.24	0.716	18.18
08/08	0.700	17.78	0.816	20.72
09/09	0.800	20.32	0.916	23.26
10/10	0.900	22.86	1.016	25.80
11/11	1.000	25.40	1.116	28.34
12/12	1.100	27.94	1.216	30.88
13/13	1.200	30.48	1.316	33.42
14/14	1.300	33.02	1.416	35.96
15/15	1.400	35.56	1.516	38.50
16/16	1.500	38.10	1.616	41.04
17/17	1.600	40.64	1.716	43.58
18/18	1.700	43.18	1.816	46.12
19/19	1.800	45.72	1.916	48.66
20/20	1.900	48.26	2.016	51.20
21/21	2.000	50.80	2.116	53.74
22/22	2.100	53.34	2.216	56.28
23/23	2.200	55.88	2.316	58.82
24/24	2.300	58.42	2.416	61.36
25/25	2.400	60.96	2.516	63.90
26/26	2.500	63.50	2.616	66.44
27/27	2.600	66.04	2.716	68.98
28/28	2.700	68.58	2.816	71.52
29/29	2.800	71.12	2.916	74.06
30/30	2.900	73.66	3.016	76.60
31/31	3.000	76.20	3.116	79.14
32/32	3.100	78.74	3.216	81.68
33/33	3.200	81.28	3.316	84.22
34/34	3.300	83.82	3.416	86.76
35/35	3.400	86.36	3.516	89.30
36/36	3.500	88.90	3.616	91.84
37/37	3.600	91.44	3.716	94.38
38/38	3.700	93.98	3.816	96.92
39/39	3.800	96.52	3.916	99.46
40/40	3.900	99.06	4.016	102.00

PART NUMBER CODING
SFM850-NPPC-S_-S_-BK

MOUNTING STYLES

- C - SURFACE MOUNT, SINGLE ROW
PIN 1 (STANDARD)
- D - SURFACE MOUNT, SINGLE ROW
PIN 1 (OPPOSITE BEND)

NUMBER OF POSITIONS

(CONTACTS PER ROW, 02 THRU 40)

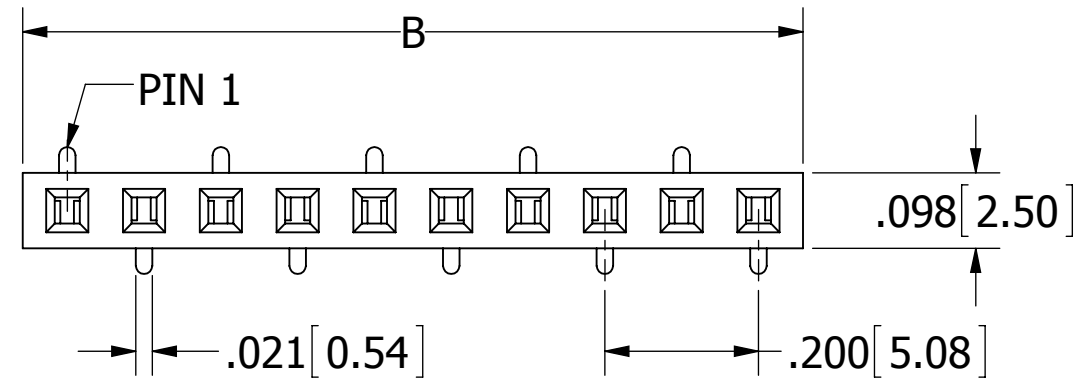

SFM850-NPPC-S_-SC-BK
(STANDARD)

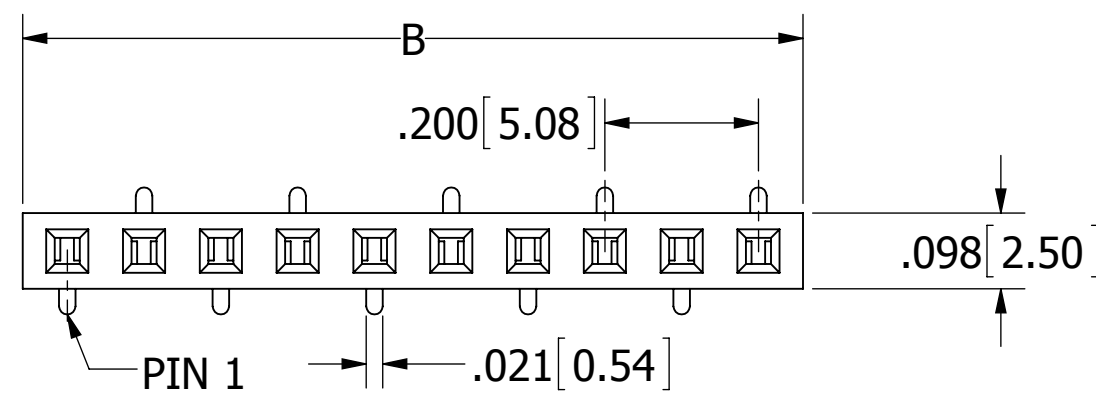

SFM850-NPPC-S_-SD-BK
(OPPOSITE BEND, APPLICABLE ON EVEN PIN COUNTS)

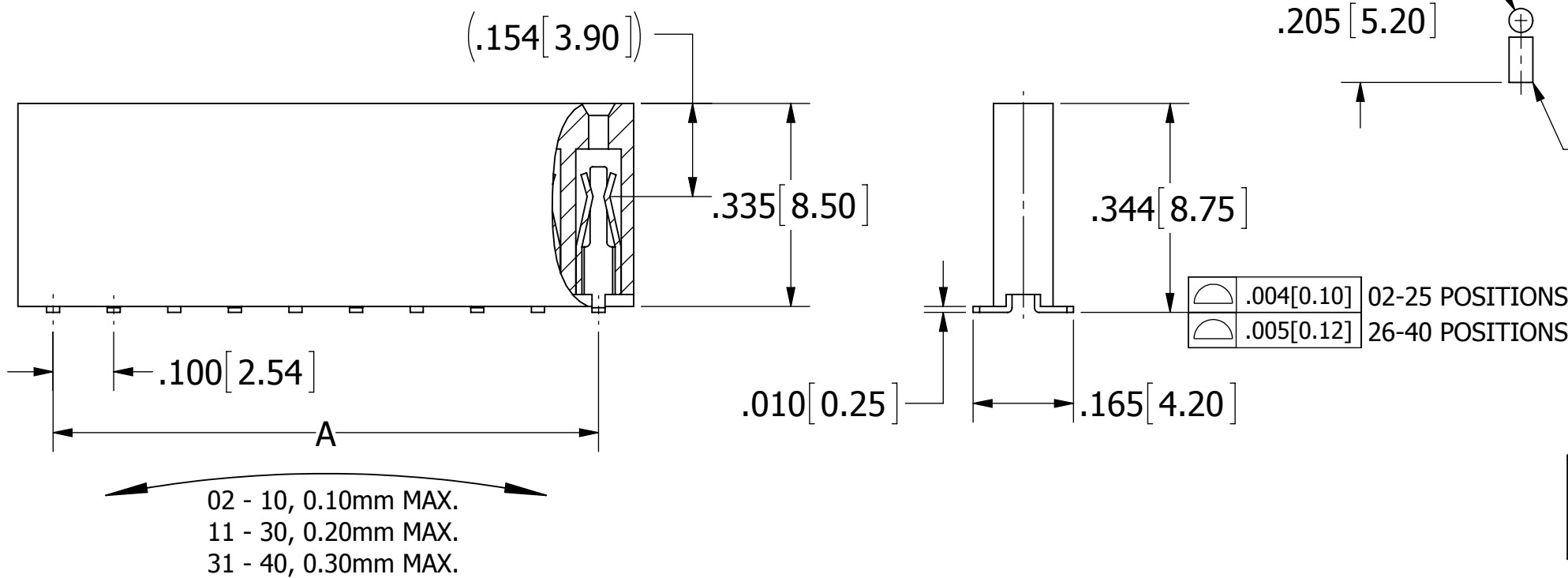

02 - 10, 0.10mm MAX.
11 - 30, 0.20mm MAX.
31 - 40, 0.30mm MAX.

REVISIONS				
REV.	ECO. NO	DESCRIPTION	DATE	BY
A	2399	INITIAL RELEASE	07/15/2011	GC
B	3090	UPGRADE INSULATOR MATERIAL AND UPDATE 'B' DIMENSION TABLE	10/29/2014	LH
C	3522	UPDATE FRONT VIEW, ADD WARP TOLERANCE AND SMT TAIL COPLANAR TOLERANCE ON DRAWING	09/06/2016	LH

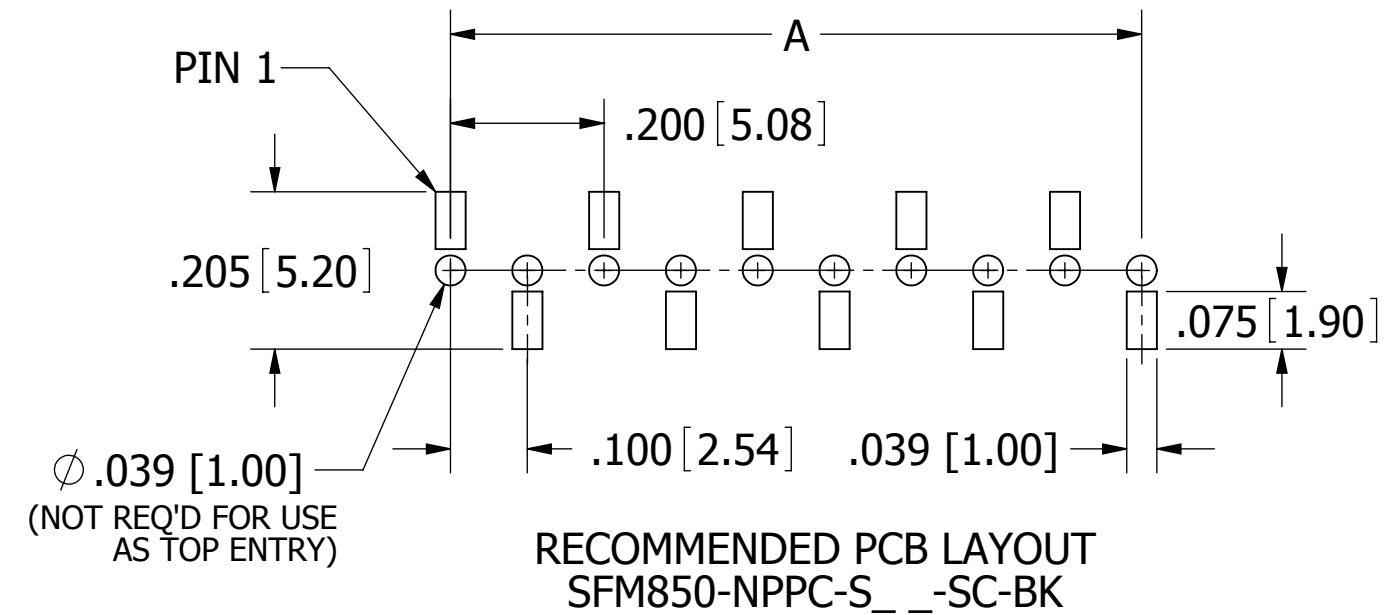

RECOMMENDED PCB LAYOUT
SFM850-NPPC-S_-SC-BK

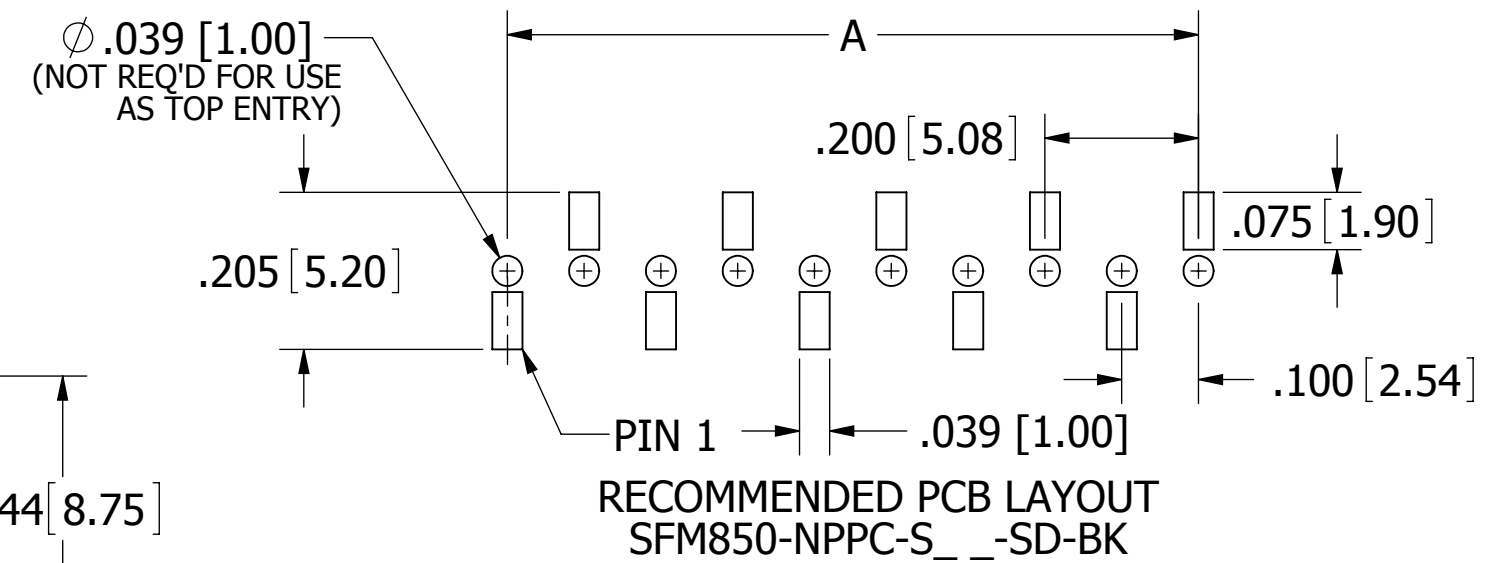

RECOMMENDED PCB LAYOUT
SFM850-NPPC-S_-SD-BK

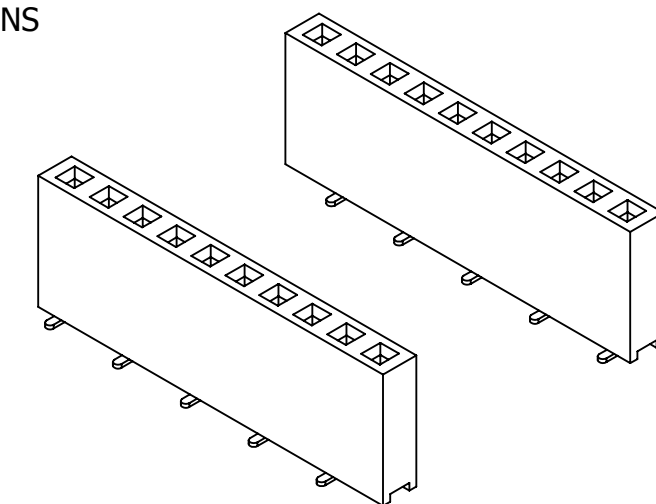

NOTES:

- INSULATOR MATERIAL: NYLON 9T, UL 94V-0, COLOR: BLACK
- CONTACT MATERIAL: PHOSPHOR BRONZE
- CONTACT PLATING: .000030" - .000050" NICKEL UNDERPLATE, GOLD FLASH OVERALL.
- CURRENT RATING: 3 AMPS
- INSULATOR RESISTANCE: 5000 MEGOHMS MIN.
- CONTACT RESISTANCE: 20 MILLIOHMS MAX.
- DIELECTRIC WITHSTANDING: 1000 V AC
- OPERATING TEMPERATURE: -40°C TO +105°C
- *PROCESSING TEMP.: 230°C MAX FOR 60 SECONDS (260°C MAX FOR 10 SECONDS)
- FOR TOP/BOTTOM ENTRY
- CONSULT FACTORY FOR THE MATE IF BEING USED AS BOTTOM ENTRY.
* (INDICATED TEMPERATURE AND TIME IS FOR COMPONENT INSULATOR. HIGHER PROCESSING TEMPERATURES MAY BE USED, PROVIDED HEAT IS APPLIED FROM BACK SIDE OF PCB, AND INSULATOR DOES NOT EXCEED INDICATED TEMPERATURE AND TIME.)

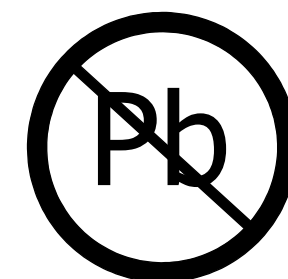

RoHS COMPLIANT

UNLESS OTHERWISE SPECIFIED: DIMENSIONS ARE IN INCHES [MM]	DRAWN	DATE	NAME	
		07/15/11	GC	
TOLERANCES:				<small>THE INFORMATION HEREIN CONTAINS PROPRIETARY INFORMATION OF SULLINS ELECTRONICS AND IS NOT TO BE REPRODUCED, USED OR DISCLOSED TO OTHERS FOR ANY PURPOSE EXCEPT AS SPECIFICALLY AUTHORIZED IN WRITING BY AN OFFICER OF SULLINS ELECTRONICS.</small>
ANGULAR: ± 1°				
DECIMALS				TITLE
.XX = ± .012 [.3]				HEADER FEMALE, .100 CC, T/B ENTRY
.XXX = ± .008 [.20]				PART NUMBER
.XXXX = ± .0040 [.100]				SFM850-NPPC-S_-S_-BK
SCALE: 4:1		SIZE	CAGE CODE	DWG. NO.
		C	54453	11810
				REV
				C
				SHEET 1 OF 1