

PART NUMBER	REVISION	DESCRIPTION	FEED TYPE
2151790-1	D	FINE CRIMP HEIGHT ADJUST	MECHANICAL
2151790-2	F	FINE CRIMP HEIGHT ADJUST	PNEUMATIC
7-2151790-1	D	MECHANICAL AND CRIMP TOOLING KIT	MECHANICAL
7-2151790-2	F	PNEUMATIC AND CRIMP TOOLING KIT	PNEUMATIC
7-2151790-7	A	CRIMP TOOLING KIT	-

ATLANTIC VERSION TERMINATOR INTERFACE ADAPTER

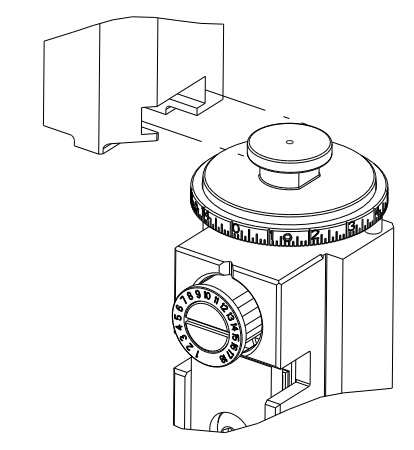

APPLICATOR DATA		
CRIMP	SIZE	TYPE
WIRE	1.07 mm [.042]	F
INSUL	1.50 mm [.059]	F

APPLICATOR INSTRUCTIONS 408-35042

TERMINAL DATA: JST TERMINAL JST CRIMP SPECIFICATION			
TERMINAL NAME: PH CONNECTOR			
WIRE STRIP LENGTH	INSULATION DIAMETER RANGE		
1.90-2.50 mm [.075-.098 IN]	Ø0.90-1.50 mm [.035-.059 IN]		
TERMINAL APPLICATION SPECIFICATION	HM-0047 Rev R	-	-
TERMINALS APPLIED			
TE TERMINAL	JST TERMINAL	TE TERMINAL	STM TERMINAL
1949141-3	SPH-002T-P0.5S	1949141-2	2426PS
1949141-1	SPH-002T-P0.5		

TERMINAL DATA: JST TERMINAL JST CRIMP SPECIFICATION			
TERMINAL NAME: PH CONNECTOR			
WIRE STRIP LENGTH	INSULATION DIAMETER RANGE		
1.90-2.50 mm [.075-.098 IN]	Ø0.90-1.50 mm [.035-.059 IN]		
TERMINAL APPLICATION SPECIFICATION	HM-0047 Rev R	-	-
TERMINALS APPLIED			
TE TERMINAL	JST TERMINAL	TE TERMINAL	JST TERMINAL
1949141-4	SPH-002T-P0.5L	-	-

TERMINAL DATA: HSM TERMINAL JST CRIMP SPECIFICATION			
TERMINAL NAME: PH CONNECTOR			
WIRE STRIP LENGTH	INSULATION DIAMETER RANGE		
1.90-2.50 mm [.075-.098 IN]	Ø0.90-1.50 mm [.035-.059 IN]		
TERMINAL APPLICATION SPECIFICATION	HM-0047 Rev R	-	-
TERMINALS APPLIED			
TE TERMINAL	HSM TERMINAL	TE TERMINAL	HSM TERMINAL
3311024-1	T2003-TPO0000R	-	-

WIRE SIZE	CRIMP HEIGHT mm [INCH]	CRIMP HEIGHT REFERENCE SETTING
24 AWG	0.65+/-0.025 [.025+/- .001]	9.1
26 AWG	0.60+/-0.025 [.023+/- .001]	9.6
28 AWG	0.58+/-0.025 [.023+/- .001]	9.8
30 AWG	0.55+/-0.025 [.021+/- .001]	10.2

WIRE SIZE	CRIMP HEIGHT mm [INCH]	CRIMP HEIGHT REFERENCE SETTING
24 AWG	0.595+/-0.025 [.023+/- .001]	9.6
26 AWG	0.545+/-0.025 [.021+/- .001]	10.2
28 AWG	0.525+/-0.025 [.021+/- .001]	10.4

WIRE SIZE	CRIMP HEIGHT mm [INCH]	CRIMP HEIGHT REFERENCE SETTING
24 AWG	0.65+/-0.025 [.025+/- .001]	9.1
26 AWG	0.60+/-0.025 [.023+/- .001]	9.6
28 AWG	0.58+/-0.025 [.023+/- .001]	9.8
30 AWG	0.55+/-0.025 [.021+/- .001]	10.2

- 1 RECOMMENDED SPARE PARTS
- 2 REFER TO SUPPLIED INSTRUCTION SHEET FOR CLEANING, LUBRICATION AND STORAGE OF APPLICATOR.
- 3 APPLY PART NUMBER 2-23419-6 LOCTITE TO THREADS OF ITEM 242.
- 4 CRIMP HEIGHT REFERENCE SETTING WAS THE SETTING USED WHEN THE APPLICATOR WAS QUALIFIED AT THE FACTORY. ADJUSTMENT MAY BE NECESSARY WHEN RUNNING APPLICATOR IN THE FIELD.
- 5. UNLESS SPECIFIED OTHERWISE TORQUE VALUES SHALL BE USED PER DOCUMENT, 101-35000.

***WARNING**
ON INSTALLATION, SET WIRE DISC TO CRIMP HEIGHT REFERENCE SETTING FOR LARGEST WIRE SIZE. CRIMP HEIGHT REFERENCE SETTINGS GREATER THAN THE VALUE SHOWN MAY CAUSE DAMAGE TO THE CRIMP TOOLING. REFER TO THE INSTRUCTION SHEET FOR PROPER SETUP AND ADJUSTMENTS.

LOC	DIST	REVISIONS					
A	66	P	LTN	DESCRIPTION	DATE	OWN	APVD
		C		ECR-18-007000	07MAY2018	TB	JDG
		C1		ECR-18-016661	22OCT2018	MZ	KZ
		D		ECR-19-001803	02FEB2019	FL	CT
		F		ECR-21-110877	19AUG2021	JWC	RK

-	1	-	1	-	2119641-1	FEED CAM, AIR FEED	248	
-	1	1	1	1	2119082-8	CAM, SNAIL, INSULATION ADJUSTMENT	244	
-	1	1	1	1	2079764-1	WASHER, WAVE SPRING, CREST-TO-CREST	243	
-	1	1	1	1	2119083-1	RETAINER, INSULATION DIAL	242	
-	1	1	1	1	7-18023-7	SCR, SKT HD CAP M3 X 4.0	241	
-	-	1	-	1	2119580-1	MECHANICAL FEED ASSEMBLY	239	
-	1	-	1	-	2844940-1	AIR FEED MODULE	238	
-	REF	REF	REF	REF	994970-2	COUNTER, MAGNETIC	164	
-	1	1	1	1	1-18028-2	WASHER, FLAT, REG M4	119	
-	1	1	1	1	2844908-1	SCREW, LOCKING	99	
-	1	1	1	1	2844907-1	POST, LOCKING	98	
-	1	1	1	1	1-455888-1	SPACER, CRIMPER	82	
-	1	1	1	1	547505-3	SPRING, COMPRESSION	77	
-	1	1	1	1	854769-4	HOLDER, INS	74	
-	1	1	1	1	1803607-3	DOCUMENTATION PACKAGE	71	
-	1	1	1	1	2119791-5	DEPRESSOR, WIRE	70	
-	1	1	1	1	2119740-1	TAG IDENTIFICATION	67	
-	2	2	2	2	2168078-1	SCREW, DRIVE, RH, RoHS, 2 x .188	66	
-	1	1	1	1	2168083-2	SCR, SKT HD CAP, RoHS, M4 X 8.0	60	
-	1	1	1	1	5-18022-5	SCR, HEX HD CAP, M4 X 6.0	59	
-	1	1	1	1	21028-2	PIN, SLOTTED SPRING .062 X .250	58	
-	1	1	1	1	1338685-1	PAWL, FEED	56	
-	2	2	2	2	2168083-3	SCR, SKT HD CAP, RoHS, M4 X 12.0	54	
-	2	2	2	2	1-2168083-4	SCR, SKT HD CAP, RoHS, M4 X 5	53	
-	1	2	1	2	18023-9	SCR, SKT HD CAP M4 X 6.0	49	
-	-	1	-	1	2119652-1	FEED CAM, PRE FEED	48	
-	-	1	-	1	2119653-1	FEED CAM, POST FEED	47	
-	1	1	1	1	1803583-9	APPLICATOR BASIC ASSEMBLY, SF	46	
-	1	1	1	1	1803515-1	RAM ASSEMBLY, SF ATLANTIC	44	
-	1	1	1	1	1803602-1	SCR, BHSC, RoHS (M8 X 25)	41	
-	2	2	2	2	2079383-5	SCR, BHSC, RoHS (M4 X 20)	33	
-	2	2	2	2	2-2844962-8	SPACER, CYLINDRICAL, STRIP GUIDE	30	
-	1	1	1	1	2844992-1	ASSEMBLY, STRIP GUIDE	29	
-	1	1	1	1	1-455888-0	SPACER, CRIMPER	28	
-	1	1	1	1	1320928-2	STRIP GUIDE	24	
-	1	1	1	1	2168083-2	SCR, SKT HD CAP, RoHS, M4 X 8.0	21	
-	1	1	1	1	1-18028-2	WASHER, FLAT, REG M4	20	
-	1	1	1	1	2119533-4	STRIPPER, SIDE FEED	19	
-	1	1	1	1	2-690518-8	HOLD DOWN, TERMINAL	18	
-	1	1	1	1	2119806-1	INSERT, SHEAR	13	
-	1	1	1	1	3-22280-3	SPRING, COMPRESSION	12	
-	1	1	1	1	1-356885-4	STOP, SHEAR	11	
-	1	1	1	1	2119805-1	SHEAR HOLDER, FRONT	10	
-	1	1	1	1	1633861-1	SHEAR, FLOATING	9	
-	1	2	2	1	1	2-1333228-0	ANVIL	8
-	-	-	-	-	-	-	7	
-	-	-	-	-	-	-	6	
-	1	1	1	1	2119780-6	DEPRESSOR, SHEAR	5	
-	1	1	1	1	2-238011-0	BLOCK, CRIMPER SPACER	4	
-	1	2	2	1	1	2-2119582-3	CRIMPER, INSULATION F PREMIUM	3
-	-	-	-	-	-	-	2	
-	1	2	2	1	1	2-456401-4	CRIMPER, WIRE .042 F PREMIUM	1

ATLANTIC VERSION
Shown on sheets 1 of 4 & 2 of 4
(Pacific version shown on sheets 3 of 4 & 4 of 4)

DIMENSIONS:		TOLERANCES UNLESS OTHERWISE SPECIFIED:		MATERIAL:	
mm	0 PLC ±	1 PLC ±	2 PLC ±	3 PLC ±	4 PLC ±
	ANGLES ±	FINISH			

OWN	CHK	DATE	NAME	SIZE	CAGE CODE	DRAWING NO	RESTRICTED TO
H. HUANG	S. XI	24OCT2012	Ocean Side Feed Applicator	A1	00779	2151790	-

Customer Accessible Production Drawing SCALE 1:2 SHEET 1 OF 4 REV F

LOC	DIST	REVISIONS					
A	66	P	LTN	DESCRIPTION	DATE	DWN	APVD
		-		SEE SHEET 1		-	-

FEED TYPE MECHANICAL

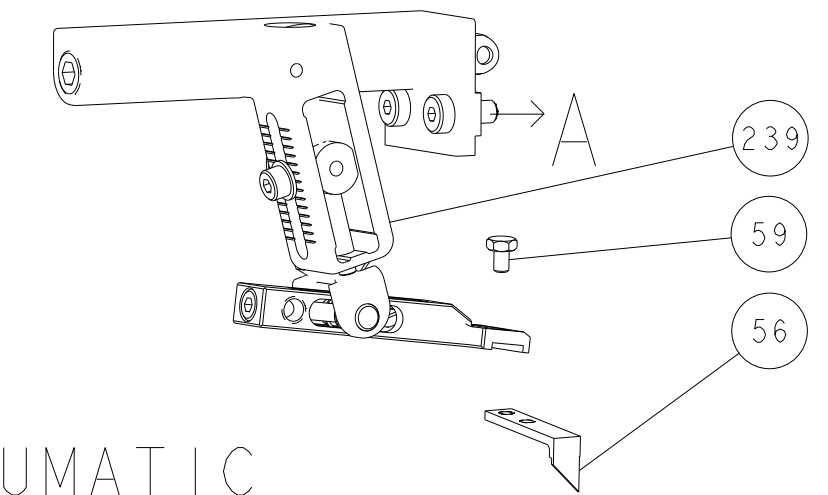

PNEUMATIC

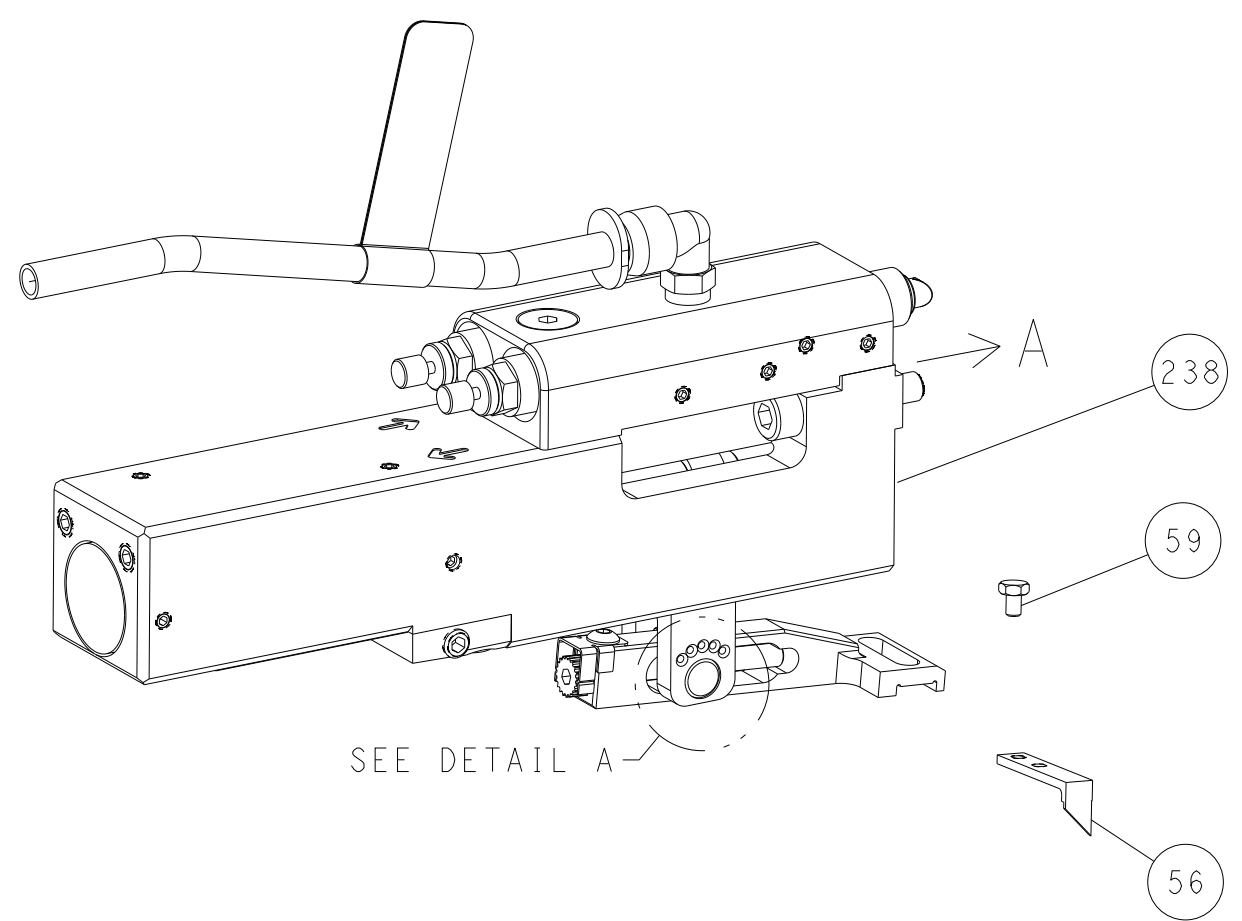

FEED SPRING SETTING POSITION (SHOWN FROM REAR SIDE)

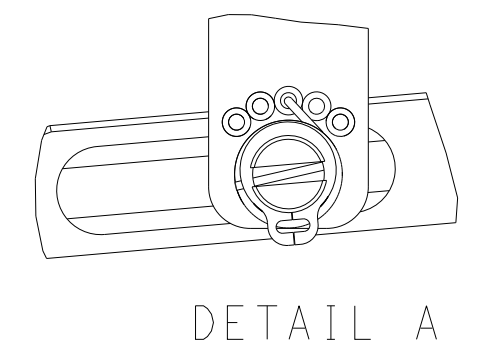

DETAIL A

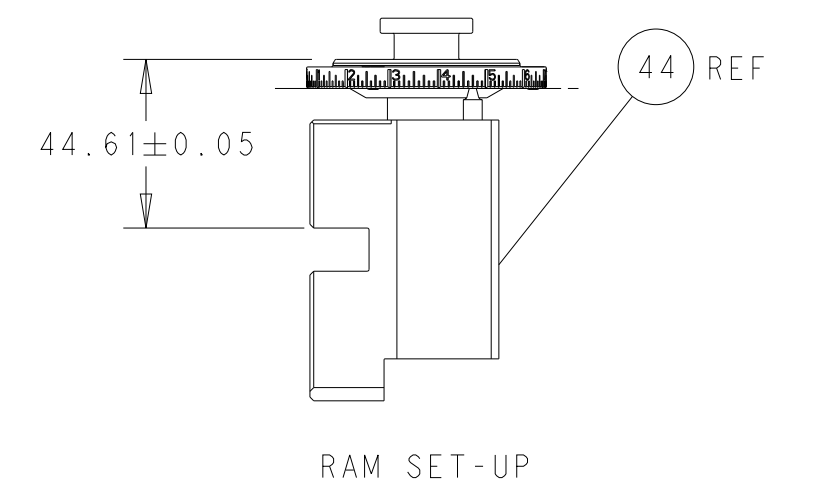
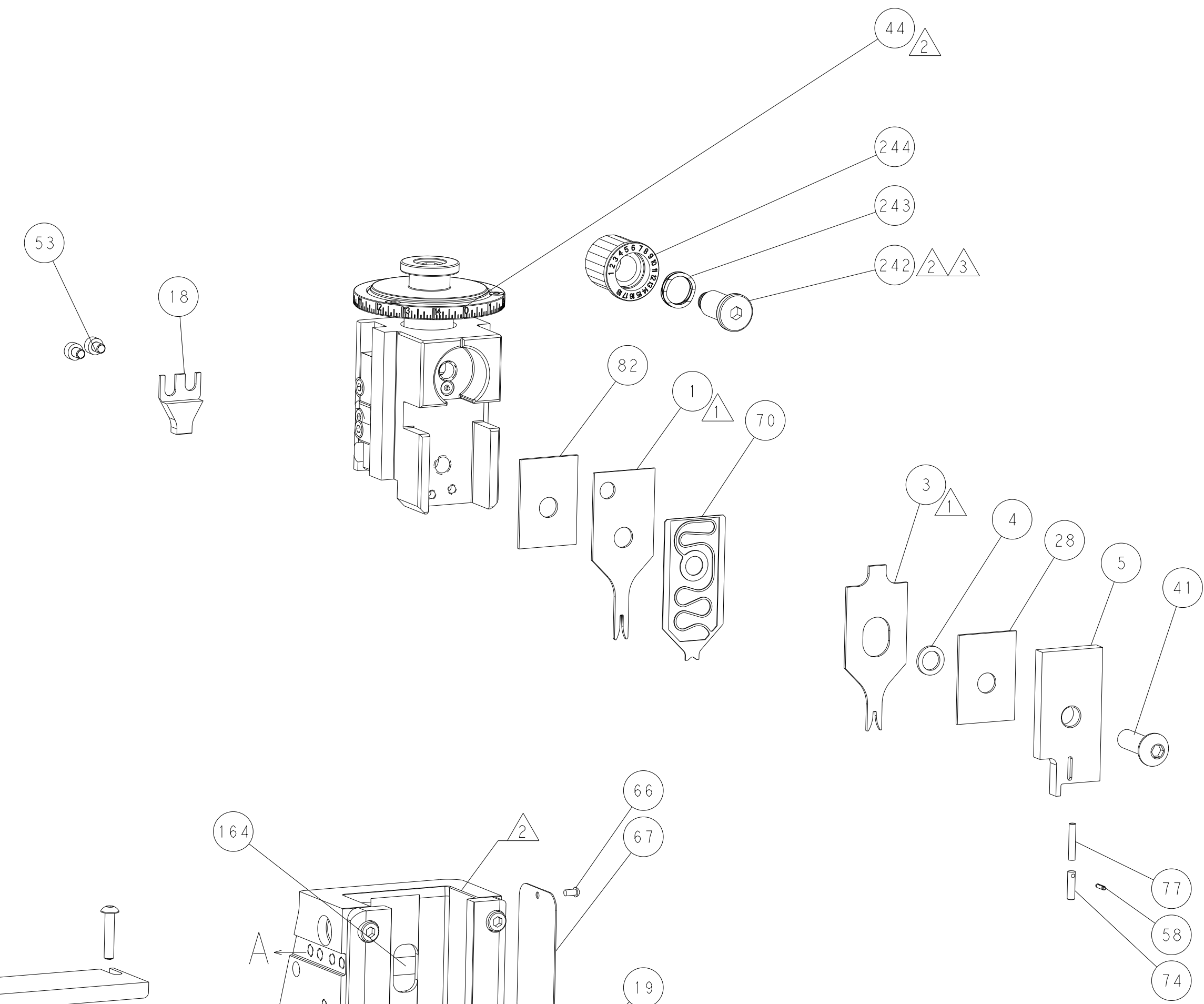

RAM SET-UP

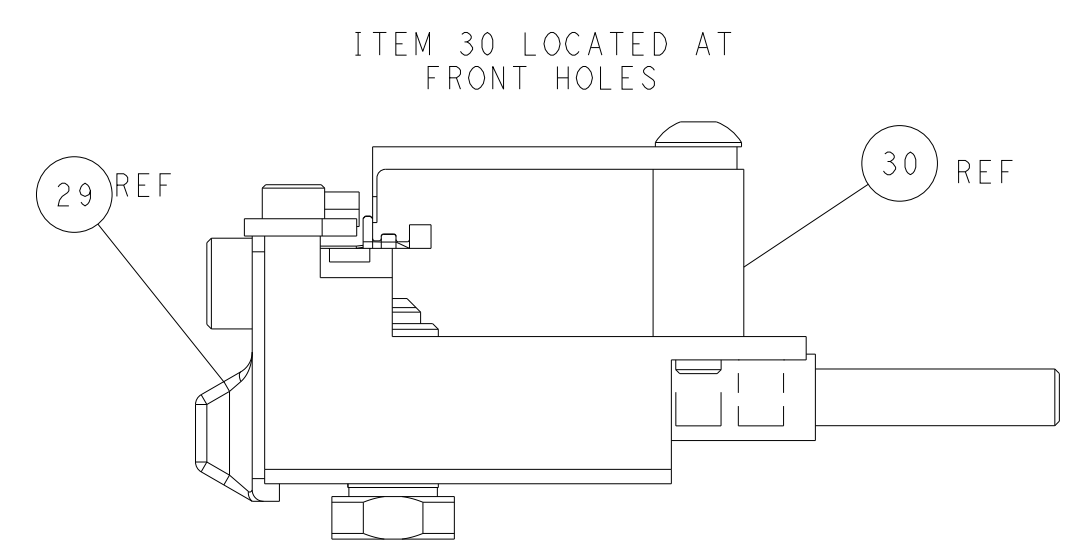
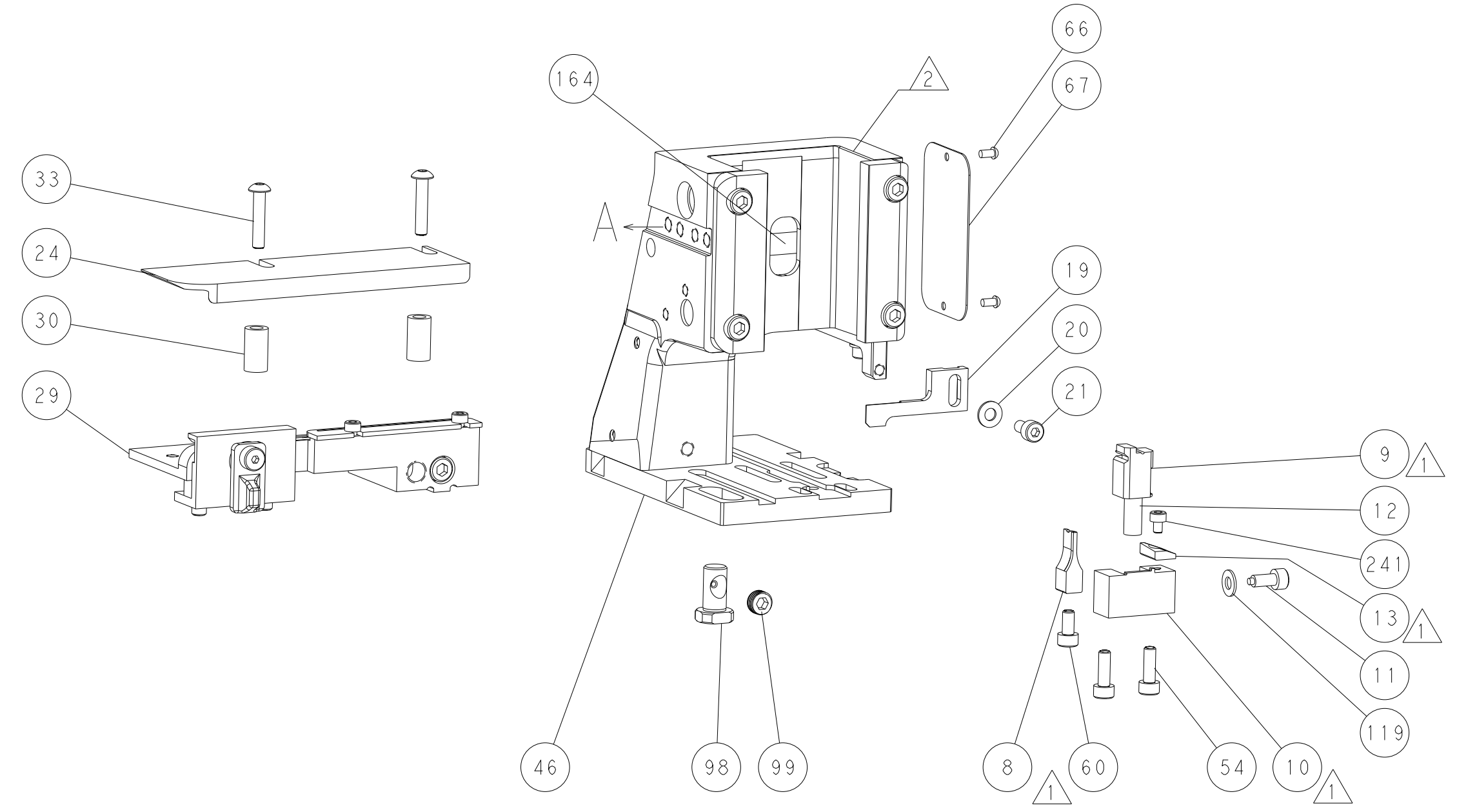

FEED TRACK POSITION GUIDE BY INSULATION BARREL

CAM POSITIONS

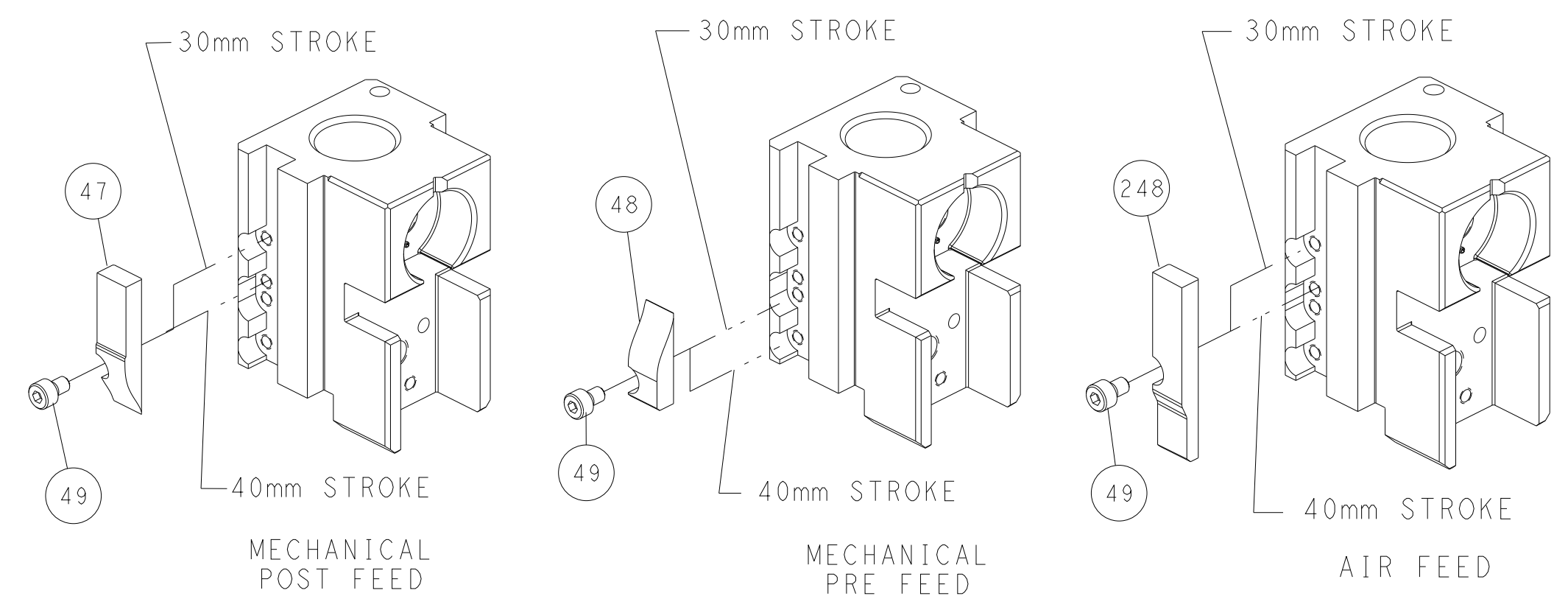

ATLANTIC VERSION
 Shown on sheets 1 of 4 & 2 of 4
 (Pacific version shown on sheets 3 of 4 & 4 of 4)

<small>THIS DRAWING IS UNPUBLISHED. RELEASED FOR PUBLICATION BY TYCO ELECTRONICS CORPORATION. ALL RIGHTS RESERVED.</small>		DWN: H. HUANG 24OCT2012 CHK: S. XI 24OCT2012 APVD: S. XI 24OCT2012	NAME: Ocean Side Feed Applicator SIZE: A1 CAGE CODE: 00779 DRAWING NO: C-2151790	TE Connectivity Harrisburg, PA 17105-3608
DIMENSIONS: mm TOLERANCES UNLESS OTHERWISE SPECIFIED: 0 PLC ± 1 PLC ± 2 PLC ± 3 PLC ± 4 PLC ± ANGLES FINISH ±	MATERIAL:	WEIGHT:	SCALE: 1:2 SHEET: 2 of 4 REV: F	RESTRICTED TO:

PART NUMBER	REVISION	DESCRIPTION	FEED TYPE
2-2151790-1	D	FINE CRIMP HEIGHT ADJUST	MECHANICAL
2-2151790-2	F	FINE CRIMP HEIGHT ADJUST	PNEUMATIC
7-2151790-7	A	CRIMP TOOLING KIT	-

PACIFIC VERSION TERMINATOR INTERFACE ADAPTER

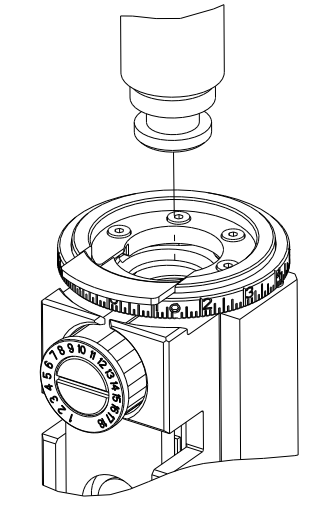

APPLICATOR DATA		
CRIMP	SIZE	TYPE
WIRE	1.07 mm [.042]	F
INSUL	1.50 mm [.059]	F

APPLICATOR INSTRUCTIONS
408-35042

TERMINAL DATA: JST TERMINAL JST CRIMP SPECIFICATION			
TERMINAL NAME: PH CONNECTOR			
WIRE STRIP LENGTH	INSULATION DIAMETER RANGE		
1.90-2.50 mm [.075-.098 IN]	Ø0.90-1.50 mm [.035-.059 IN]		
TERMINAL APPLICATION SPECIFICATION	HM-0047 Rev R	-	-
TERMINALS APPLIED			
TE TERMINAL	JST TERMINAL	TE TERMINAL	STM TERMINAL
1949141-3	SPH-002T-P0.5S	1949141-2	2426PS
1949141-1	SPH-002T-P0.5	-	-

TERMINAL DATA: JST TERMINAL JST CRIMP SPECIFICATION			
TERMINAL NAME: PH CONNECTOR			
WIRE STRIP LENGTH	INSULATION DIAMETER RANGE		
1.90-2.50 mm [.075-.098 IN]	Ø0.90-1.50 mm [.035-.059 IN]		
TERMINAL APPLICATION SPECIFICATION	HM-0047 Rev R	-	-
TERMINALS APPLIED			
TE TERMINAL	JST TERMINAL	TE TERMINAL	JST TERMINAL
1949141-4	SPH-002T-P0.5L	-	-

TERMINAL DATA: HSM TERMINAL JST CRIMP SPECIFICATION			
TERMINAL NAME: PH CONNECTOR			
WIRE STRIP LENGTH	INSULATION DIAMETER RANGE		
1.90-2.50 mm [.075-.098 IN]	Ø0.90-1.50 mm [.035-.059 IN]		
TERMINAL APPLICATION SPECIFICATION	HM-0047 Rev R	-	-
TERMINALS APPLIED			
TE TERMINAL	HSM TERMINAL	TE TERMINAL	HSM TERMINAL
3311024-1	T2003-TPO00000R	-	-

WIRE SIZE	CRIMP HEIGHT mm [INCH]	CRIMP HEIGHT REFERENCE SETTING
24 AWG	0.65+/-0.025 [.025+/- .001]	9.1
26 AWG	0.60+/-0.025 [.023+/- .001]	9.6
28 AWG	0.58+/-0.025 [.023+/- .001]	9.8
30 AWG	0.55+/-0.025 [.021+/- .001]	10.2

WIRE SIZE	CRIMP HEIGHT mm [INCH]	CRIMP HEIGHT REFERENCE SETTING
24 AWG	0.595+/-0.025 [.023+/- .001]	9.6
26 AWG	0.545+/-0.025 [.021+/- .001]	10.2
28 AWG	0.525+/-0.025 [.021+/- .001]	10.4

WIRE SIZE	CRIMP HEIGHT mm [INCH]	CRIMP HEIGHT REFERENCE SETTING
24 AWG	0.65+/-0.025 [.025+/- .001]	9.1
26 AWG	0.60+/-0.025 [.023+/- .001]	9.6
28 AWG	0.58+/-0.025 [.023+/- .001]	9.8
30 AWG	0.55+/-0.025 [.021+/- .001]	10.2

***WARNING**
ON INSTALLATION, SET WIRE DISC TO CRIMP HEIGHT REFERENCE SETTING FOR LARGEST WIRE SIZE. CRIMP HEIGHT REFERENCE SETTINGS GREATER THAN THE VALUE SHOWN MAY CAUSE DAMAGE TO THE CRIMP TOOLING. REFER TO THE INSTRUCTION SHEET FOR PROPER SETUP AND ADJUSTMENTS.

- 1. RECOMMENDED SPARE PARTS
- 2. REFER TO SUPPLIED INSTRUCTION SHEET FOR CLEANING, LUBRICATION AND STORAGE OF APPLICATOR.
- 3. APPLY PART NUMBER 2-23419-6 LOCTITE TO THREADS OF ITEM 242.
- 4. CRIMP HEIGHT REFERENCE SETTING WAS THE SETTING USED WHEN THE APPLICATOR WAS QUALIFIED AT THE FACTORY. ADJUSTMENT MAY BE NECESSARY WHEN RUNNING APPLICATOR IN THE FIELD.
- 5. UNLESS SPECIFIED OTHERWISE TORQUE VALUES SHALL BE USED PER DOCUMENT, 101-35000.

LOC	DIST	REVISIONS					
		P	LTN	DESCRIPTION	DATE	OWN	APVD
A	66	-	-	SEE SHEET 1	-	-	-

-	1	1	2119082-8	CAM, SNAIL, INSULATION ADJUSTMENT	244
-	1	1	2079764-1	WASHER, WAVE SPRING, CREST-TO-CREST	243
-	1	1	2119083-1	RETAINER, INSULATION DIAL	242
-	1	1	7-18023-7	SCR, SKT HD CAP M3 X 4.0	241
-	-	1	2119580-1	MECHANICAL FEED ASSEMBLY	239
-	1	-	2844940-1	AIR FEED MODULE	238
-	REF	REF	994970-2	COUNTER, MAGNETIC	164
-	1	1	2119641-2	FEED CAM, AIR FEED	151
-	1	1	2168083-8	SCR, SKT HD CAP, RoHS, M4 X 16	144
-	2	2	2168083-9	SCR, SKT HD CAP, RoHS, M4 X 20	143
-	-	1	2119653-2	FEED CAM, POST FEED	142
-	1	1	1-1803583-0	APPLICATOR BASIC ASSEMBLY, SF	141
-	1	1	1803516-1	RAM ASSEMBLY, SF PACIFIC	140
-	1	1	1-18028-2	WASHER, FLAT, REG M4	119
-	1	1	2844908-1	SCREW, LOCKING	99
-	1	1	2844907-1	POST, LOCKING	98
-	1	1	1-455888-1	SPACER, CRIMPER	82
-	1	1	547505-3	SPRING, COMPRESSION	77
-	1	1	854769-4	HOLDER, INS	74
-	1	1	1803607-3	DOCUMENTATION PACKAGE	71
-	1	1	2119791-5	DEPRESSOR, WIRE	70
-	1	1	2119740-1	TAG IDENTIFICATION	67
-	2	2	2168078-1	SCREW, DRIVE, RH, RoHS, 2 x .188	66
-	1	1	5-18022-5	SCR, HEX HD CAP, M4 X 6.0	59
-	-	1	21028-2	PIN, SLOTTED SPRING .062 X .250	58
-	1	1	1338685-1	PAWL, FEED	56
-	2	2	1-2168083-4	SCR, SKT HD CAP, RoHS, M4 X 5	53
-	1	2	18023-9	SCR, SKT HD CAP M4 X 6.0	49
-	-	1	2119652-1	FEED CAM, PRE FEED	48
-	1	1	1803602-1	SCR, BHSC, RoHS (M8 X 25)	41
-	2	2	2079383-5	SCR, BHSC, RoHS (M4 X 20)	33
-	2	2	2-2844962-8	SPACER, CYLINDRICAL, STRIP GUIDE	30
-	1	1	2844992-1	ASSEMBLY, STRIP GUIDE	29
-	1	1	1-455888-0	SPACER, CRIMPER	28
-	1	1	1320928-2	STRIP GUIDE	24
-	1	1	2168083-2	SCR, SKT HD CAP, RoHS, M4 X 8.0	21
-	1	1	1-18028-2	WASHER, FLAT, REG M4	20
-	1	1	2119533-4	STRIPPER, SIDE FEED	19
-	1	1	2-690518-8	HOLD DOWN, TERMINAL	18
-	1	1	2119806-1	INSERT, SHEAR	13
-	1	1	3-22280-3	SPRING, COMPRESSION	12
-	1	1	1-356885-4	STOP, SHEAR	11
-	1	1	2119805-1	SHEAR HOLDER, FRONT	10
-	1	1	1633861-1	SHEAR, FLOATING	9
-	1	1	2-1333228-0	ANVIL	8
-	-	-	-	-	7
-	-	-	-	-	6
-	1	1	2119780-6	DEPRESSOR, SHEAR	5
-	1	1	2-238011-0	BLOCK, CRIMPER SPACER	4
-	1	1	2-2119582-3	CRIMPER, INSULATION F PREMIUM	3
-	-	-	-	-	2
-	1	1	2-456401-4	CRIMPER, WIRE .042 F PREMIUM	1

PACIFIC VERSION
Shown on sheets 3 of 4 & 4 of 4
(Atlantic version shown on sheets 1 of 4 & 2 of 4)

DIMENSIONS:		TOLERANCES UNLESS OTHERWISE SPECIFIED:		DWG: H. HUANG 24OCT2012		CHK: S. XI 24OCT2012		APVD: S. XI 24OCT2012		NAME: Ocean Side Feed Applicator	
mm	0 PLC ±	1 PLC ±	2 PLC ±	3 PLC ±	4 PLC ±	ANGLES ±	FINISH	SIZE: A1	CAGE CODE: 00779	DRAWING NO: C=2151790	RESTRICTED TO: -
MATERIAL:								WEIGHT:	Customer Accessible Production Drawing		SCALE: 1:2
								SHEET 3 OF 4		REV F	

LOC	DIST	REVISIONS					
A	66	P	LTM	DESCRIPTION	DATE	DWN	APVD
		-		SEE SHEET 1			

FEED TYPE MECHANICAL

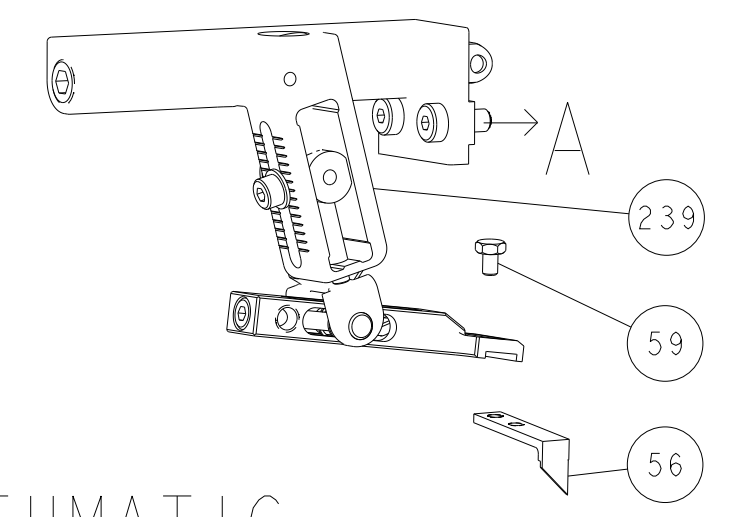

PNEUMATIC

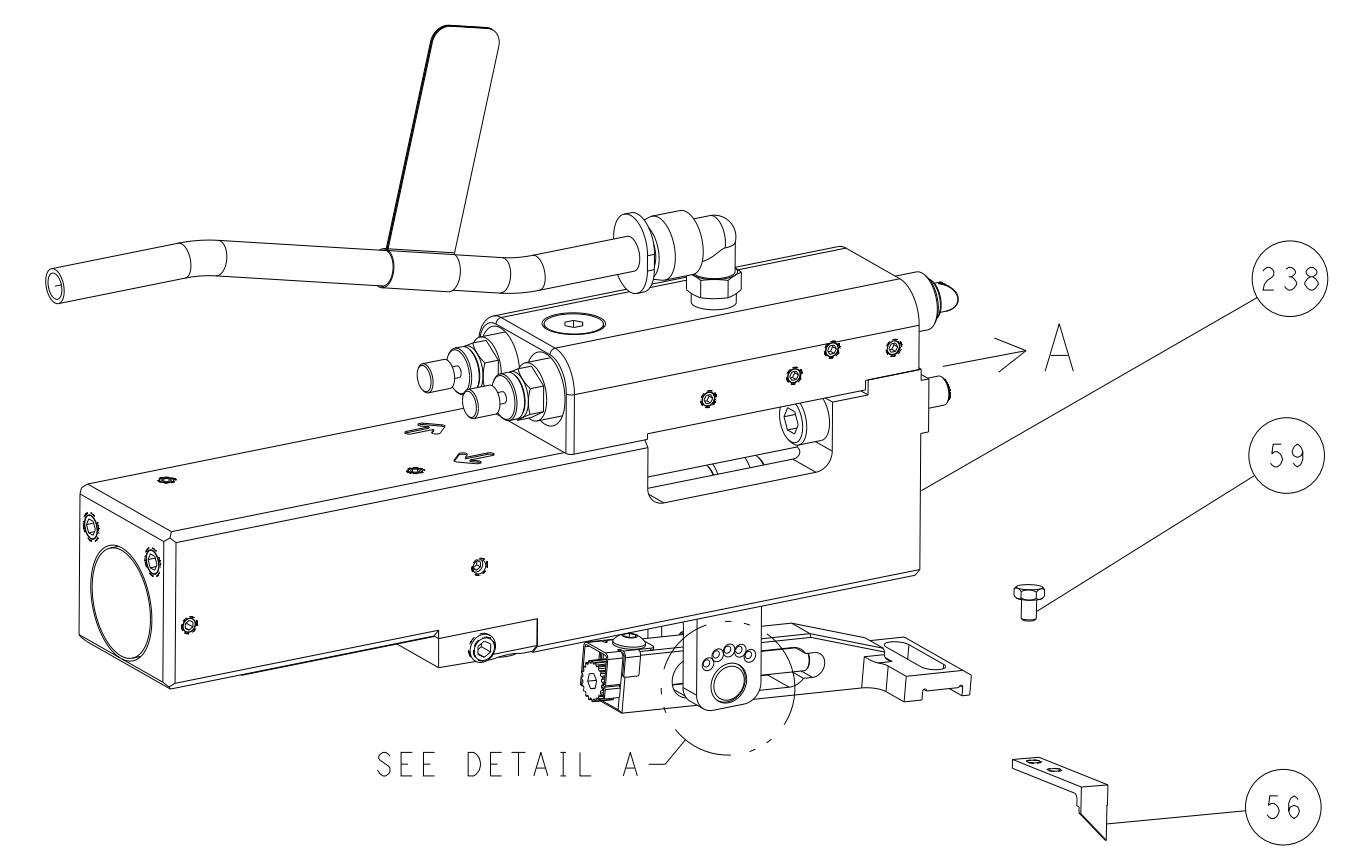

FEED SPRING SETTING POSITION (SHOWN FROM REAR SIDE)

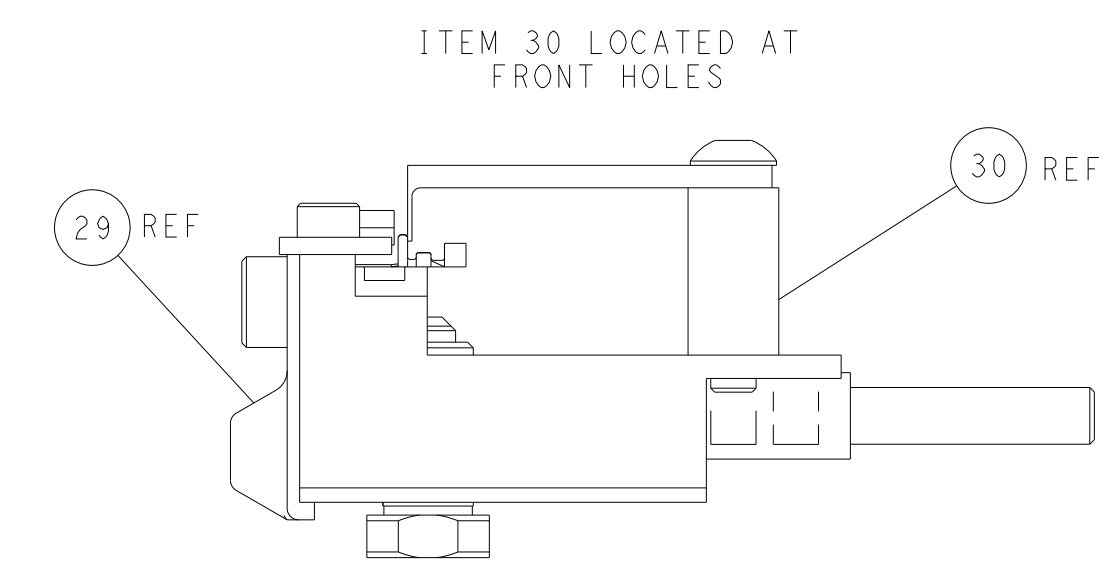
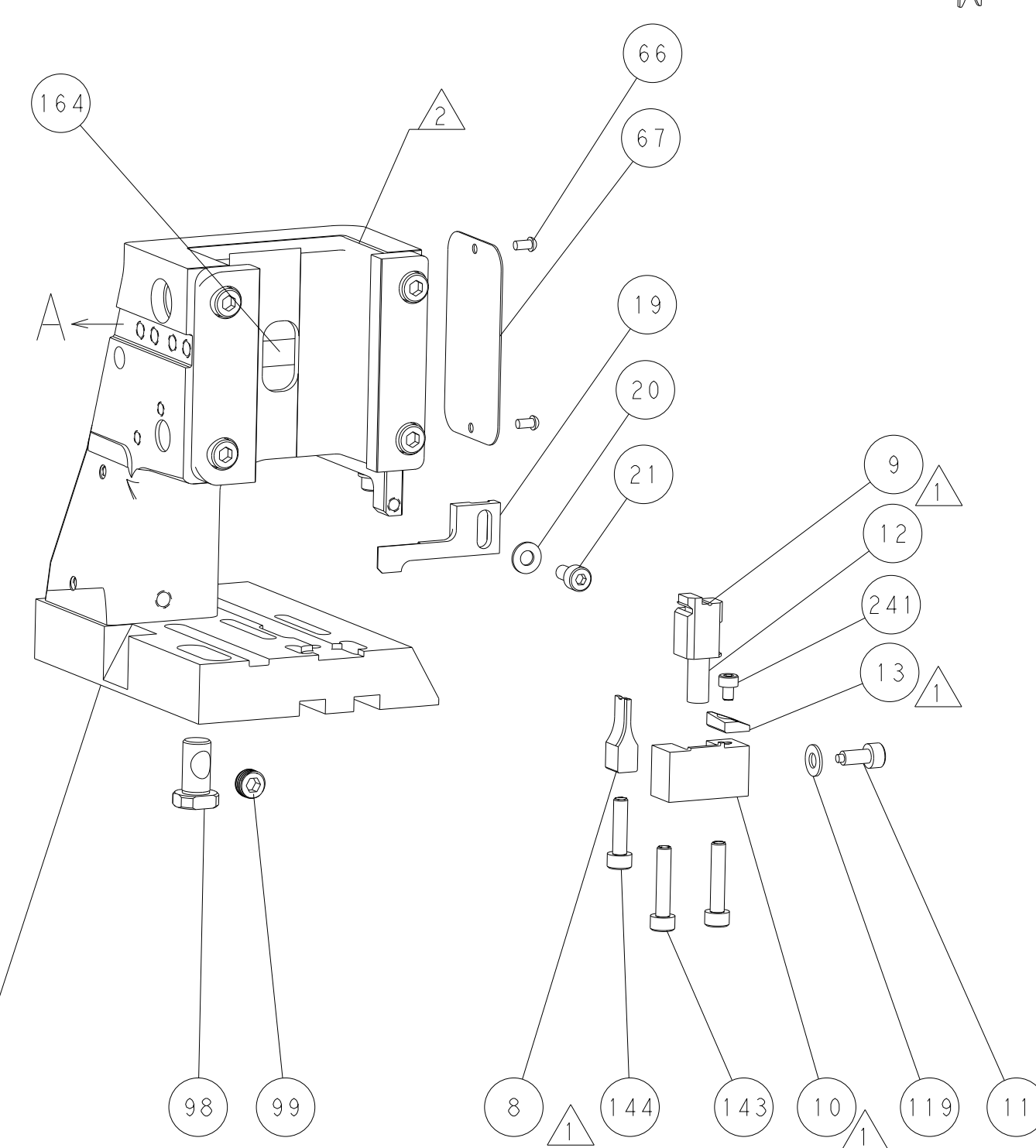
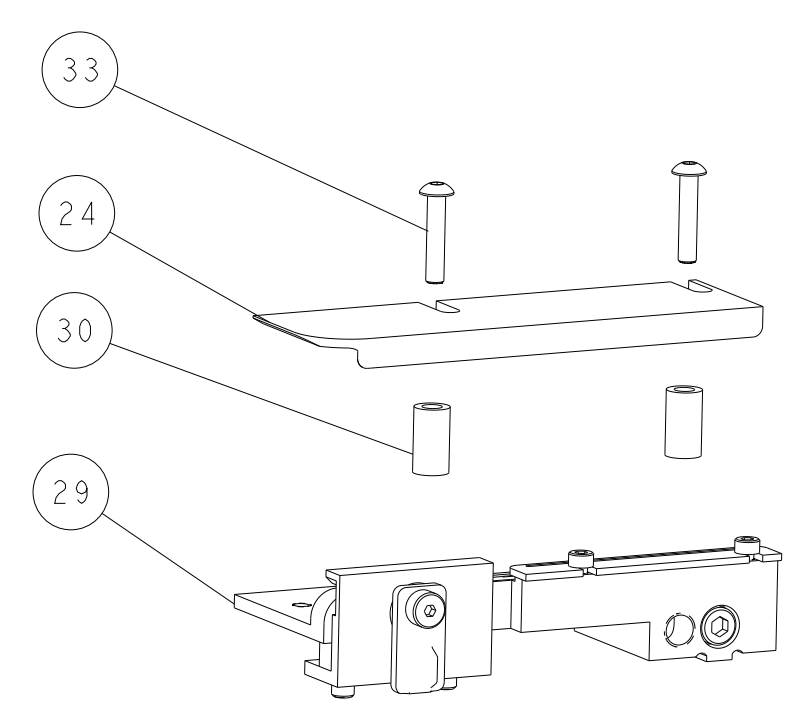
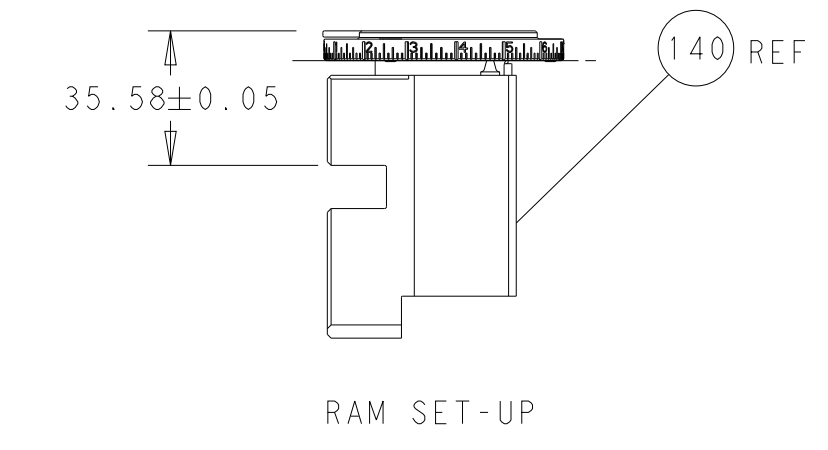
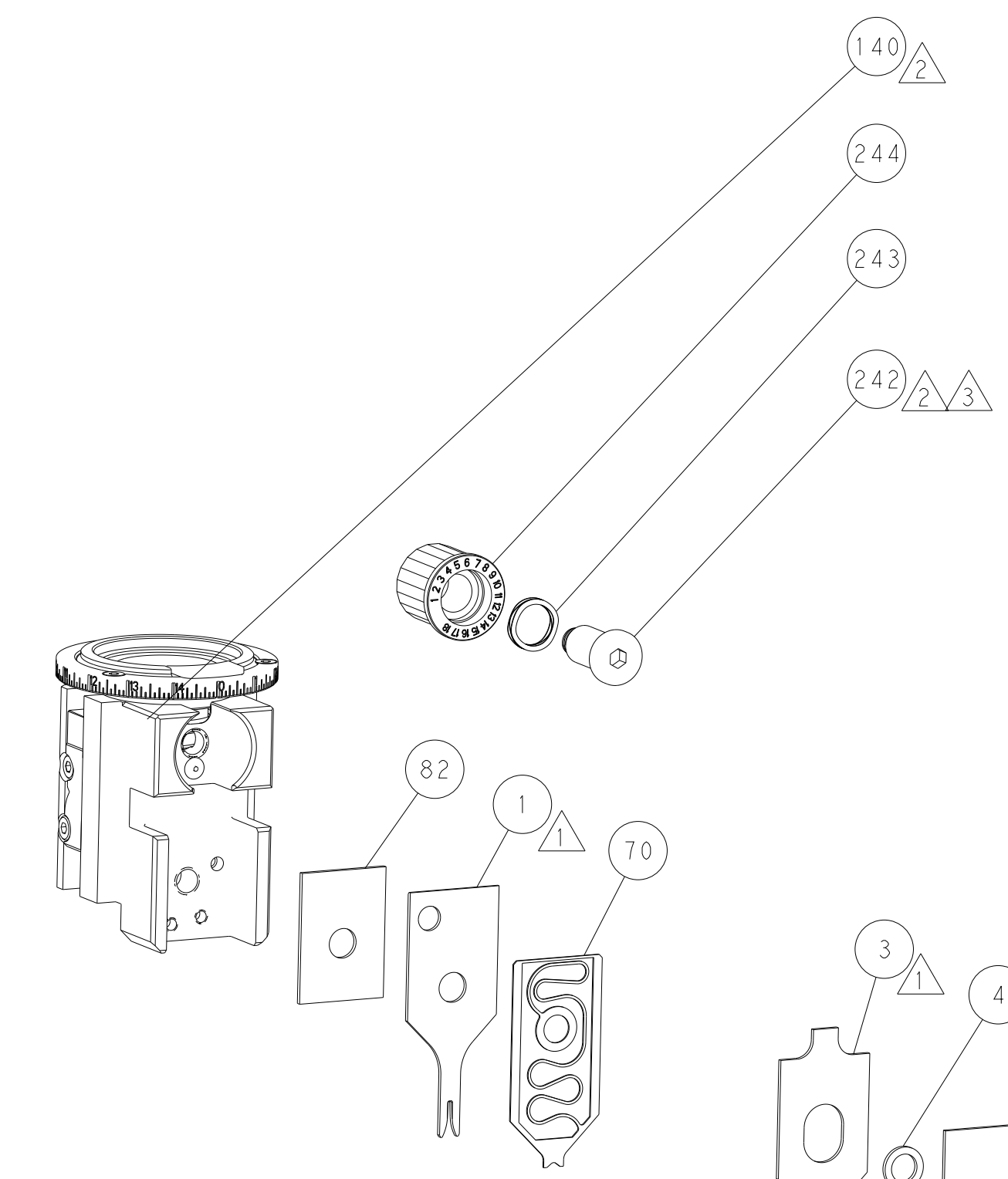
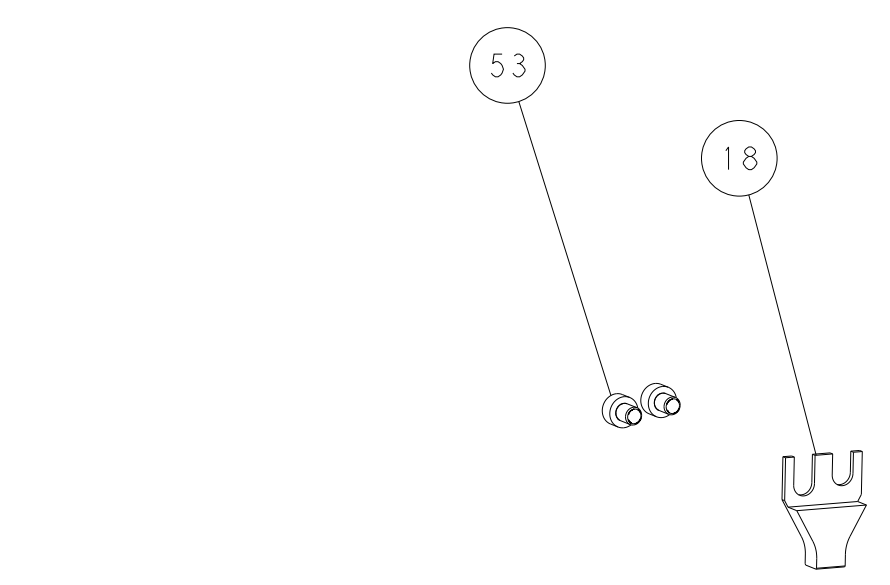
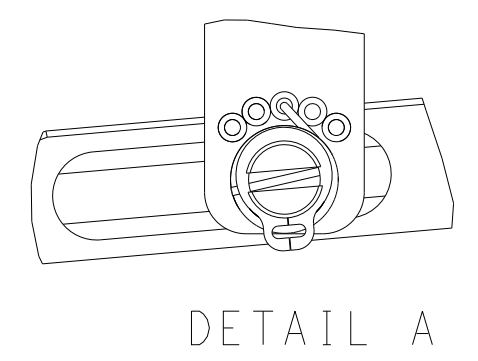

CAM POSITIONS

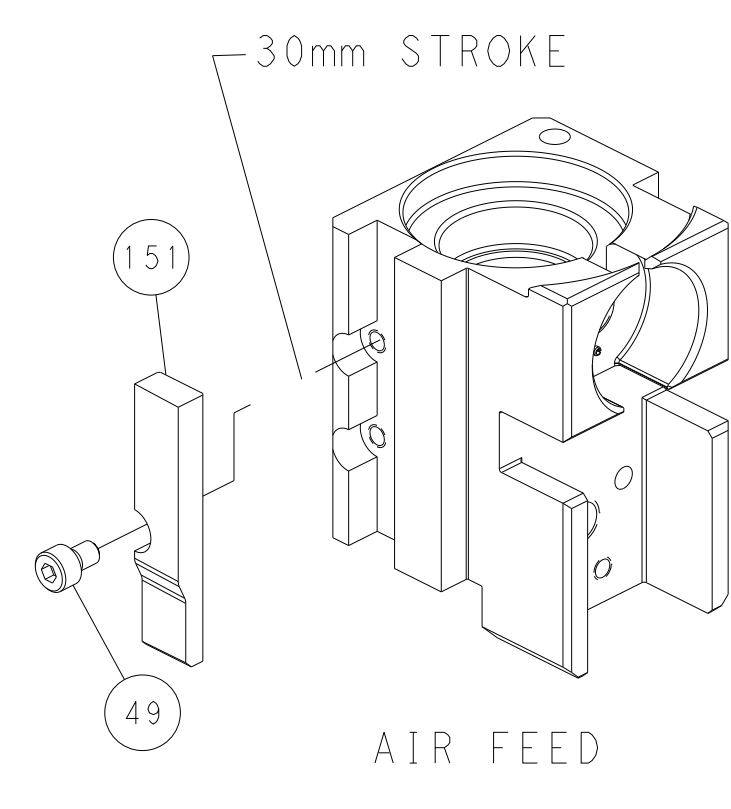
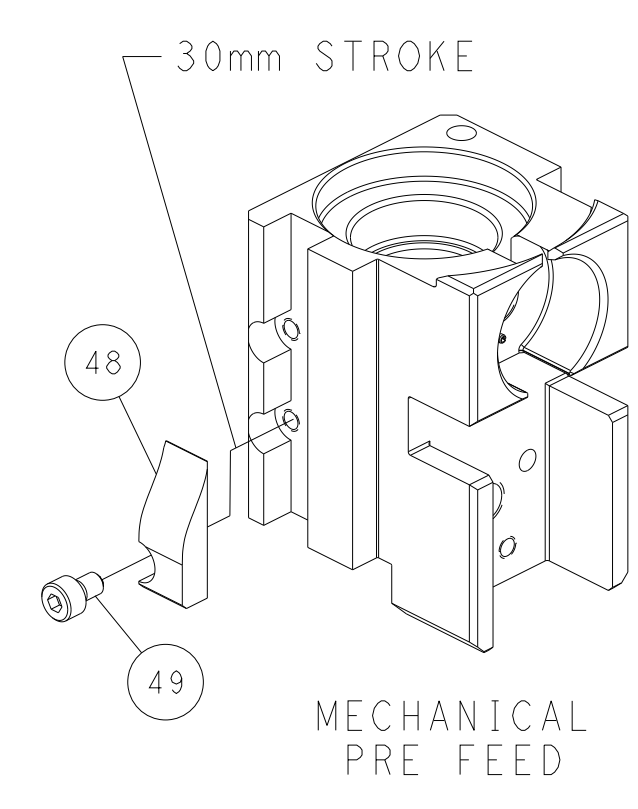
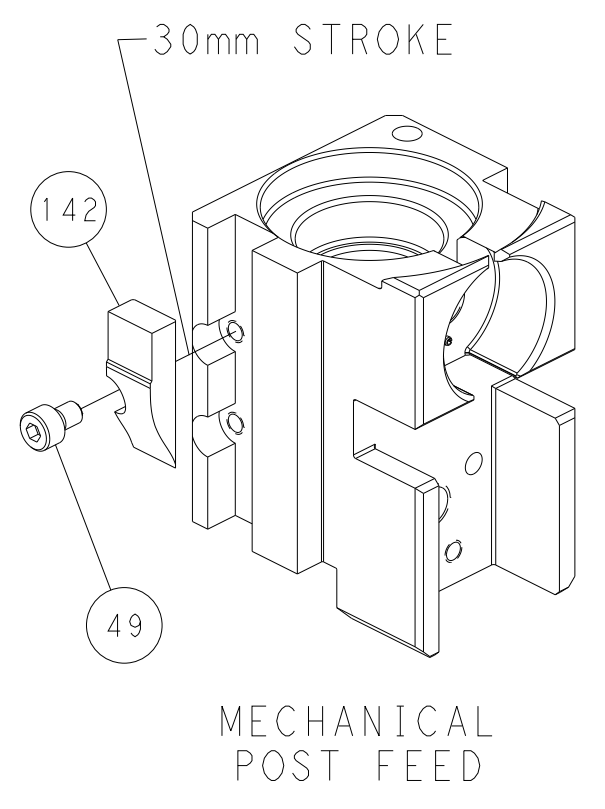

PACIFIC VERSION
 Shown on sheets 3 of 4 & 4 of 4
 (Atlantic version shown on sheets 1 of 4 & 2 of 4)

<small>THIS DRAWING IS A CONTROLLED DOCUMENT FOR TYCO ELECTRONICS CORPORATION. IT IS THE PROPERTY OF COMPANY AND IS NOT TO BE REPRODUCED OR TRANSMITTED IN ANY FORM OR BY ANY MEANS, ELECTRONIC OR MECHANICAL, WITHOUT THE WRITTEN PERMISSION OF TYCO ELECTRONICS CORPORATION. SHOULD BE CONTACTED FOR THE LATEST REVISION.</small>		DWN: H. HUANG CHK: S. XI APVD: S. XI PRODUCT SPEC: 24OCT2012 APPLICATION SPEC: 24OCT2012	NAME: Ocean Side Feed Applicator SIZE: A1 CAGE CODE: 00779 DRAWING NO: 2151790 SCALE: 1:2 SHEET: 4 OF 4 REV: F
DIMENSIONS: mm TOLERANCES UNLESS OTHERWISE SPECIFIED: 0 PLC ± 1 PLC ± 2 PLC ± 3 PLC ± 4 PLC ± ANGLES FINISH ±		WEIGHT: - MATERIAL: -	RESTRICTED TO: - CUSTOMER ACCESSIBLE PRODUCTION DRAWING