

THIS DRAWING IS UNPUBLISHED. RELEASED FOR PUBLICATION
 © COPYRIGHT - By - ALL RIGHTS RESERVED.

| LOC | DIST | REVISIONS | | | |
|-----|------|-------------|---------------------------|-----------|-------|
| P | LTR | DESCRIPTION | DATE | DWN | APVD |
| AF | 50 | F | REVISED PER ECR-12-013518 | 23NOV2012 | KH PD |

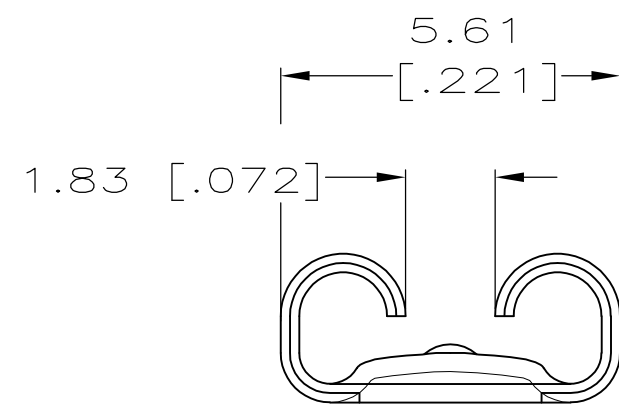

- 1 ACCEPTS WIRE SIZE [#20-#16] AWG.
- 2 INSULATION RANGE IS 2.29-3.30 [.090-.130] DIA.
- 3 CONTINUOUS STRIP ON REELS.

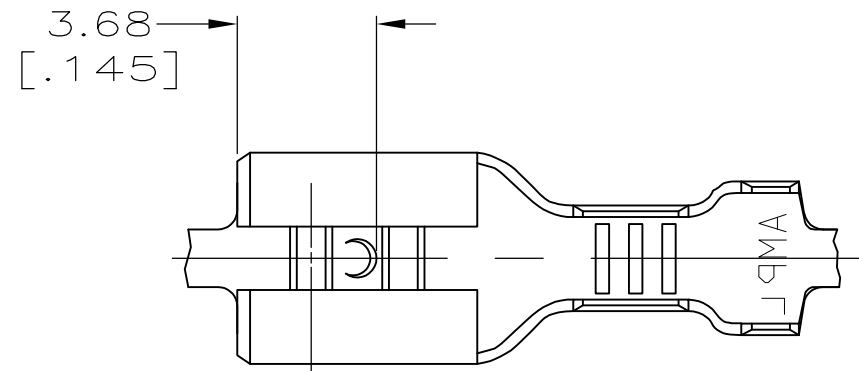
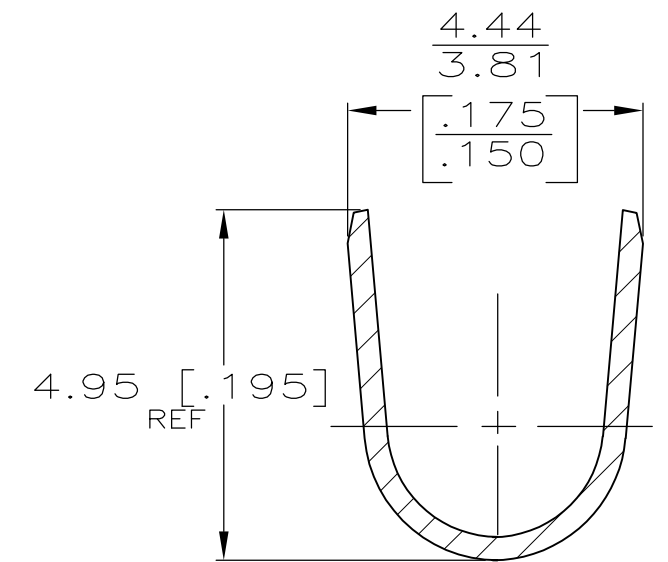
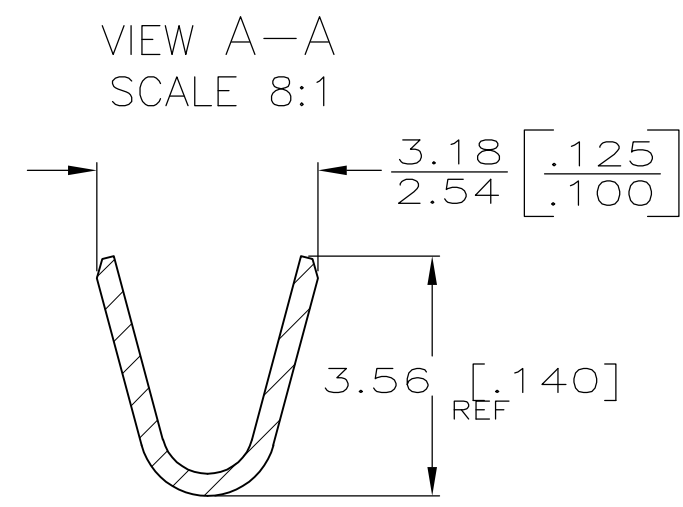
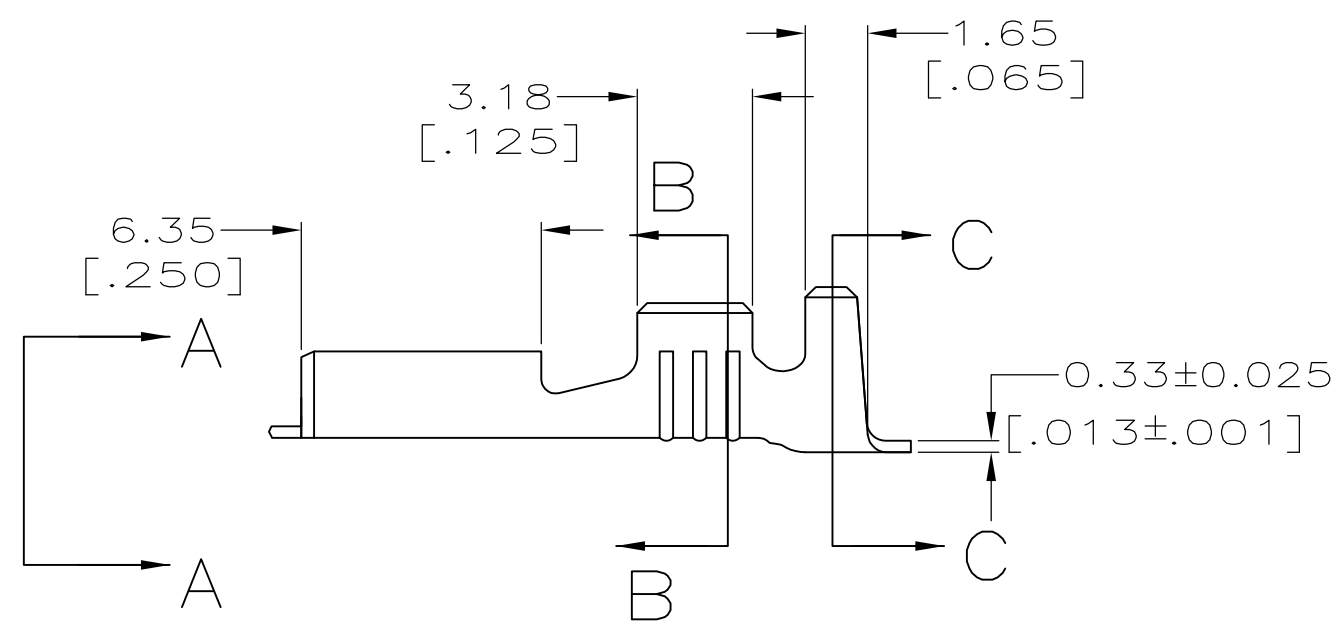

| | | | |
|----------|--------|---------------------------|--------------------|
| OBSOLETE | TIN | 0.81±0.025 [.032±.001] | 63608-2 |
| | - | | 63608-1 |
| | FINISH | MATING TAB THICKNESS | |

| | | | | | | | | | | | | | | | | | |
|--|---------------|------------------|-----------|---------------|----------------------------|-----|-------|---------------|-------|-----|-------|-----|--------|-----|--------------|---|------|
| THIS DRAWING IS A CONTROLLED DOCUMENT. | | DWN | JR RUTH | 3/4/91 | STE TE Connectivity | | | | | | | | | | | | |
| DIMENSIONS: mm [INCHES] | | CHK | MS FEHER | 3/4/91 | | | | | | | | | | | | | |
| TOLERANCES UNLESS OTHERWISE SPECIFIED: | | APVD | R BEAVER | 3/4/91 | | | | | | | | | | | | | |
| <table border="0"> <tr><td>0 PLC</td><td>± -</td></tr> <tr><td>1 PLC</td><td>± -</td></tr> <tr><td>2 PLC</td><td>± 0.25 [.010]</td></tr> <tr><td>3 PLC</td><td>± -</td></tr> <tr><td>4 PLC</td><td>± -</td></tr> <tr><td>ANGLES</td><td>± -</td></tr> </table> | | 0 PLC | ± - | 1 PLC | | ± - | 2 PLC | ± 0.25 [.010] | 3 PLC | ± - | 4 PLC | ± - | ANGLES | ± - | PRODUCT SPEC | - | NAME |
| 0 PLC | ± - | | | | | | | | | | | | | | | | |
| 1 PLC | ± - | | | | | | | | | | | | | | | | |
| 2 PLC | ± 0.25 [.010] | | | | | | | | | | | | | | | | |
| 3 PLC | ± - | | | | | | | | | | | | | | | | |
| 4 PLC | ± - | | | | | | | | | | | | | | | | |
| ANGLES | ± - | | | | | | | | | | | | | | | | |
| MATERIAL | BRASS | FINISH | SEE TABLE | WEIGHT | - | | | | | | | | | | | | |
| | | CUSTOMER DRAWING | | SIZE | A3 | | | | | | | | | | | | |
| | | | | CAGE CODE | 00779 | | | | | | | | | | | | |
| | | | | DRAWING NO | C-63608 | | | | | | | | | | | | |
| | | | | RESTRICTED TO | - | | | | | | | | | | | | |
| | | | | SCALE | 5:1 | | | | | | | | | | | | |
| | | | | SHEET | 1 OF 1 | | | | | | | | | | | | |
| | | | | REV | F | | | | | | | | | | | | |