

THESE DRAWINGS ARE THE PROPERTY OF QUALTEK ELECTRONICS AND NOT TO BE REPRODUCED FOR OR COMMUNICATED TO A THIRD PARTY WITHOUT THE EXPRESS WRITTEN PERMISSION OF AN OFFICER OF QUALTEK ELECTRONICS.

REVISION			
REV.	DESCRIPTION	DATE	APPROVED

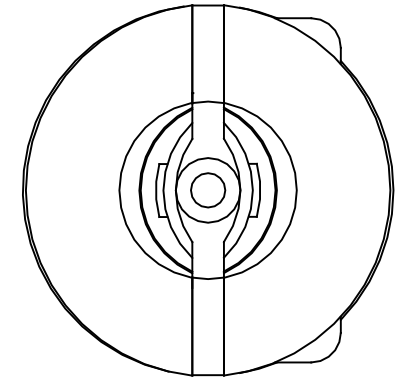
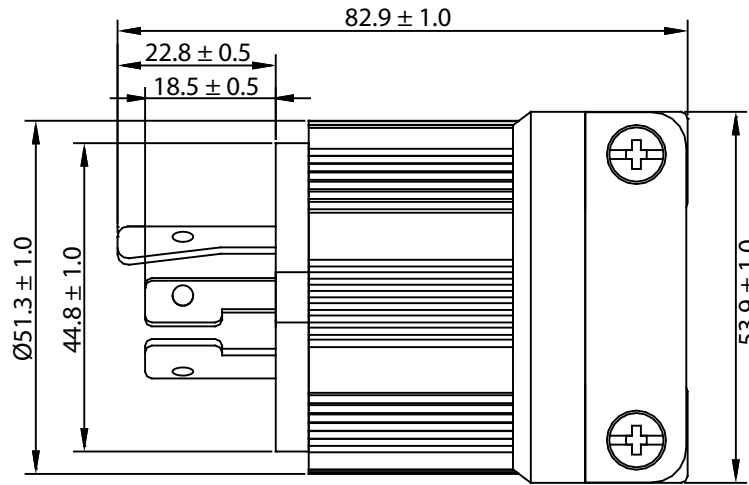
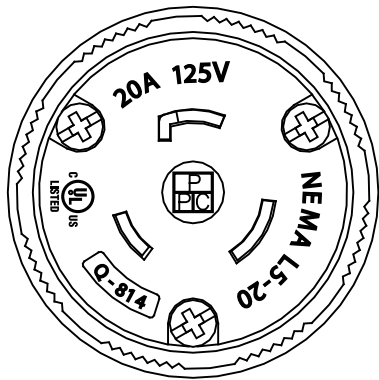

CONTROLLED

NOTES:

1. RATING: 20A 125VAC
2. COLOR: BLACK
3. CORD CLAMP: ACCEPTS 12/3 - 8/4 CABLE
4. APPROVALS: UL/cUL LISTED: E139592
5. ROHS COMPLIANT

Dim range (mm)	Tolerance +/- (mm)	Qualtek Electronics Corp. PPC DIVISION		
0-1	0.15	Part Number: Q-814		
1-6	0.20	Description: NEMA L5-20P TWIST-LOCK DEVICE		
6-18	0.30	UNIT: mm		
18-50	0.50	Drawn / Date	Checked / Date	Approved / Date
50-120	0.70	R.Nuti 08-25-09	08-25-09	LY / 08-25-09
120-250	0.90			
250-500	1.20			