

EVALUATION KIT
AVAILABLE



EEPROM-Based System Monitors with Nonvolatile Fault Memory

General Description

The MAX16031/MAX16032 EEPROM-configurable system monitors feature an integrated 10-bit analog-to-digital converter (ADC) designed to monitor voltages, temperatures, and current in complex systems. These EEPROM-configurable devices allow enormous flexibility in selecting operating ranges, upper and lower limits, fault output configuration, and operating modes with the capability of storing these values within the device.

The MAX16031 monitors up to eight voltages, three temperatures (one internal/two external remote temperature diodes), and a single current. The MAX16032 monitors up to six voltages and two temperatures (one internal/one remote temperature diode). Each of these monitored parameters is muxed into the ADC and written to its respective register that can be read back through the SMBus™ and JTAG interface.

Measured values are compared to the user-configurable upper and lower limits. For voltage measurements, there are two undervoltage and two overvoltage limits. For current and temperature, there are two sets of upper limits. Whenever the measured value is outside its limits, an alert signal is generated to notify the processor. Independent outputs are available for overcurrent, overtemperature, and undervoltage/overvoltage that are configured to assert on assigned channels. There are also undedicated fault outputs that are configured to offer a secondary limit for temperature, current, or voltage fault or provide a separate overvoltage output.

During a major fault event, such as a system shutdown, the MAX16031/MAX16032 automatically copy the internal ADC registers into the nonvolatile EEPROM registers that then are read back for diagnostic purposes.

The MAX16031/MAX16032 offer additional GPIOs that are used for voltage sequencing, additional fault outputs, a manual reset input, or read/write logic levels. A separate current-sense amplifier with an independent output allows for fast shutoff during overcurrent conditions. The MAX16031/MAX16032 are available in a 7mm x 7mm TQFN package and are fully specified from -40°C to +85°C.

Applications

| | |
|-----------------|--------------|
| Servers | Workstations |
| Storage Systems | Networking |
| Telecom | |

SMBus is a trademark of Intel Corp.



Features

- ◆ Supply Voltage Operating Range of 2.85V to 14V
- ◆ Monitors Up to Eight Voltages (Single-Ended or Pseudo-Differential) with 1% Accuracy
- ◆ EEPROM-Configurable Limits
 - Two Undervoltage and Two Overvoltage
 - Two Overtemperature
 - Two Overcurrent
- ◆ High-Side Current-Sense Amplifier with Overcurrent Output (MAX16031 Only)
- ◆ Monitors Up to Three Temperatures (1 Internal/2 Remote)
- ◆ Nonvolatile Fault Memory Stores Fault Conditions for Later Retrieval
- ◆ Two Additional Configurable Fault Outputs
- ◆ Two Configurable GPIOs
- ◆ SMBus/I²C-Compatible Interface with ALERT Output and Bus Timeout Function
- ◆ JTAG Interface
- ◆ 7mm x 7mm, 48-Pin TQFN Package

Ordering Information

| PART | TEMP RANGE | PIN-PACKAGE |
|--------------|----------------|-------------|
| MAX16031ETM+ | -40°C to +85°C | 48 TQFN-EP* |
| MAX16032ETM+ | -40°C to +85°C | 48 TQFN-EP* |

+ Denotes a lead(Pb)-free/RoHS-compliant package.

* EP = Exposed pad.

Pin Configuration

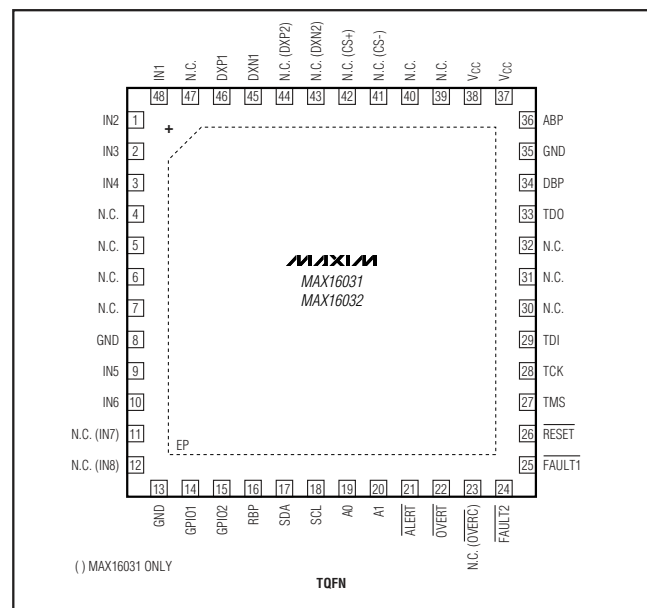

() MAX16031 ONLY

TQFN

EEPROM-Based System Monitors with Nonvolatile Fault Memory

Selector Guide

| PART | VOLTAGE MONITORS | | TEMPERATURE SENSORS | | CURRENT-SENSE AMPS | FAULT OUTPUTS | GPIOs |
|--------------|------------------|--------------|---------------------|-----|--------------------|---------------|-------|
| | SINGLE ENDED | DIFFERENTIAL | INT | EXT | | | |
| MAX16031ETM+ | 8 | 4 | 1 | 2 | 1 | 4 | 2 |
| MAX16032ETM+ | 6 | 3 | 1 | 1 | — | 4 | 2 |

Typical Application Circuit

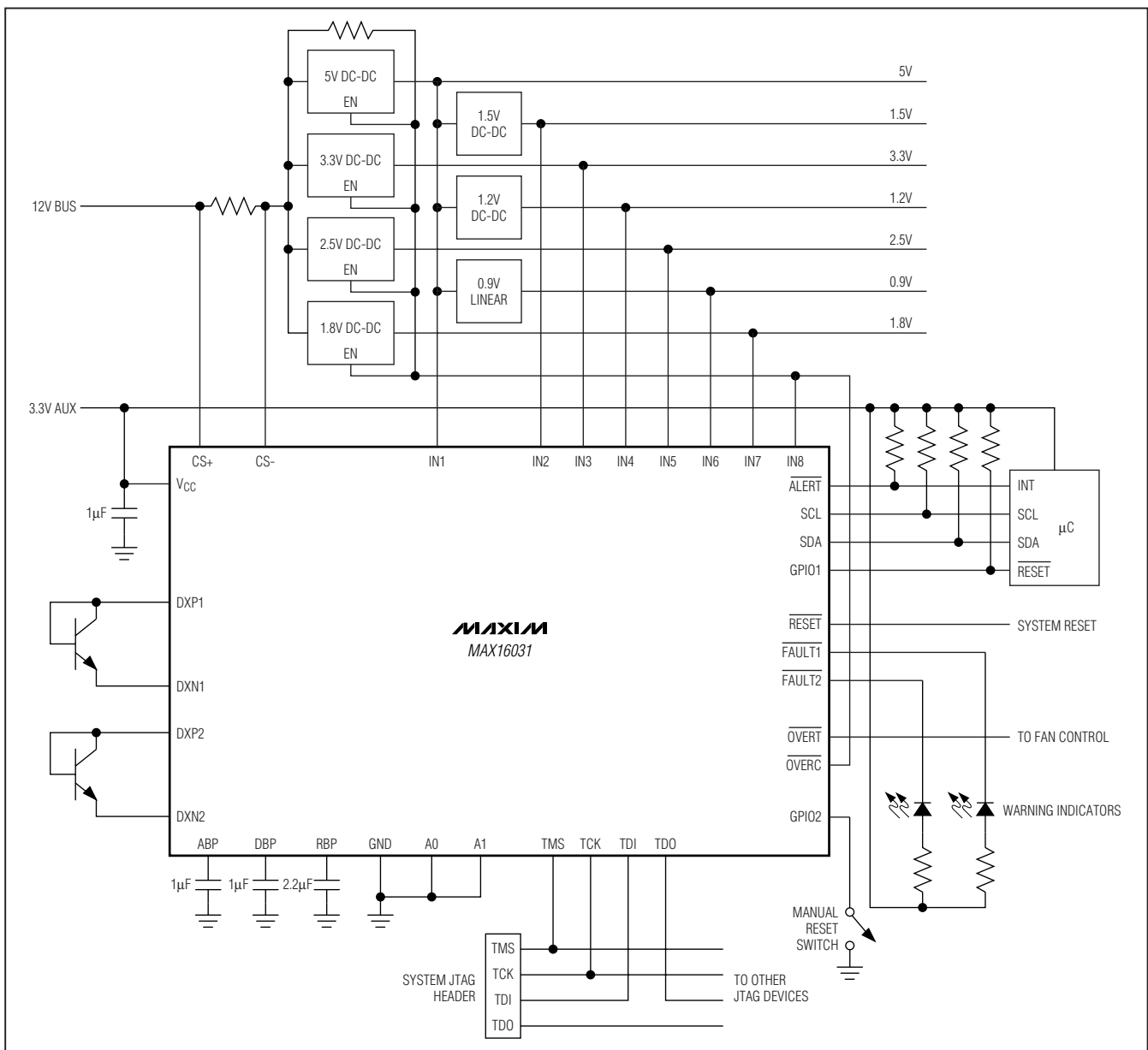

EEPROM-Based System Monitors with Nonvolatile Fault Memory

MAX16031/MAX16032

ABSOLUTE MAXIMUM RATINGS

| | |
|---|---|
| V _{CC} to GND | -0.3V to +15V |
| IN ₋ , FAULT ₋ , SCL, SDA, OVERT to GND | -0.3V to +6V |
| A0, A1, TCK, TMS, TDI to GND | -0.3V to +6V |
| OVERC, RESET, GPIO ₋ , ALERT to GND | -0.3V to +6V |
| RBP, ABP, DBP to GND | to lower of (6V and V _{CC} + 0.3V) |
| TDO, DXP1, DXP2 to GND | -0.3V to V _{DBP} + 0.3V |
| CS+, CS- to GND | -0.3V to +30V |
| (CS+ - CS-) | ±5V |
| DXN1, DXN2 to GND | -0.3V to +0.8V |
| SDA, ALERT Current | -1mA to +50mA |
| DXN1, DXN2 Current |1mA |

| | |
|---|--|
| Input/Output Current | (all except DXN1, DXN2, SDA, and ALERT).....20mA |
| Continuous Power Dissipation (T _A = +70°C) | 48-Pin, 7mm x 7mm TQFN |
| | (derate 27.8mW/°C above +70°C)2222.2mW |
| Operating Temperature Range |-40°C to +85°C |
| Junction Temperature |+150°C |
| Storage Temperature Range |-65°C to +150°C |
| Lead Temperature (soldering, 10s) |+250°C |
| Soldering Temperature (reflow) |+260°C |

Stresses beyond those listed under "Absolute Maximum Ratings" may cause permanent damage to the device. These are stress ratings only, and functional operation of the device at these or any other conditions beyond those indicated in the operational sections of the specifications is not implied. Exposure to absolute maximum rating conditions for extended periods may affect device reliability.

ELECTRICAL CHARACTERISTICS

(V_{CC} = 2.9V to 14V, T_A = -40°C to +85°C, unless otherwise specified. Typical values are at V_{CC} = 3.3V, T_A = +25°C.) (Note 1)

| PARAMETER | SYMBOL | CONDITIONS | MIN | TYP | MAX | UNITS |
|--|----------------------|---|-------|-----|-------|-------|
| Operating Voltage Range | V _{CC} | | 2.90 | | 14.00 | V |
| Undervoltage Lockout | V _{UVLO} | Minimum voltage at V _{CC} to access the digital interfaces | | | 2.8 | V |
| Undervoltage Lockout Hysteresis | V _{UVLOHYS} | | | 100 | | mV |
| Supply Current | I _{CC} | Static (EEPROM not accessed) | | 3 | 5 | mA |
| ADC DC ACCURACY | | | | | | |
| Resolution | | | | | 10 | Bits |
| Total Unadjusted Error | | T _A = -40°C to +85°C | | | 0.9 | %FSR |
| Integral Nonlinearity | | | | 1 | | LSB |
| Differential Nonlinearity | | | | 1 | | LSB |
| ADC Total Monitoring Cycle Time | t _{CYCLE} | Eight supply inputs, three temperatures, and current sense | | 80 | 100 | μs |
| ADC IN ₋ Voltage Ranges | | Register map bit set to 00 (LSB = 5.46mV) | | 5.6 | | V |
| | | Register map bit set to 01 (LSB = 2.73mV) | | 2.8 | | |
| | | Register map bit set to 10 (LSB = 1.36mV) | | 1.4 | | |
| Reference Voltage | V _{RBP} | | 1.386 | 1.4 | 1.414 | V |
| IN₋ ANALOG INPUT | | | | | | |
| Absolute Input Voltage Range (Referenced to GND) | | | 0 | | 5.6 | V |
| Input Impedance | | | 30 | 50 | 80 | kΩ |

EEPROM-Based System Monitors with Nonvolatile Fault Memory

ELECTRICAL CHARACTERISTICS (continued)

($V_{CC} = 2.9V$ to $14V$, $T_A = -40^{\circ}C$ to $+85^{\circ}C$, unless otherwise specified. Typical values are at $V_{CC} = 3.3V$, $T_A = +25^{\circ}C$.) (Note 1)

| PARAMETER | SYMBOL | CONDITIONS | MIN | TYP | MAX | UNITS | |
|---|------------|--|-------------|---------|------|---------------|----|
| Input Hysteresis | | Percent of programmed threshold | r5Ch[5] = 0 | 0.78 | | % | |
| | | | r5Ch[5] = 1 | 1.17 | | | |
| RESET OUTPUT | | | | | | | |
| Reset Timeout Period | t_{RP} | r20h[5:3] = 000; from \overline{MR} going high | 22.5 | 25 | 27.5 | μs | |
| | | r20h[5:3] = 001 | 2.25 | 2.5 | 2.75 | ms | |
| | | r20h[5:3] = 010 | 9 | 10 | 11 | | |
| | | r20h[5:3] = 011 | 36 | 40 | 44 | | |
| | | r20h[5:3] = 100 | 144 | 160 | 176 | | |
| | | r20h[5:3] = 101 | 576 | 640 | 704 | | |
| | | r20h[5:3] = 110 | 1152 | 1280 | 1408 | | |
| | | r20h[5:3] = 111 | 2304 | 2560 | 2816 | | |
| TEMPERATURE MEASUREMENTS | | | | | | | |
| Internal Sensor Measurement Error | | (Note 2) | | ± 3 | | $^{\circ}C$ | |
| External Remote Diode Temperature Measurement Error | | (Note 2) | | ± 5 | | $^{\circ}C$ | |
| Temperature Measurement Resolution | | | | 0.5 | | $^{\circ}C$ | |
| Temperature Measurement Noise | | Internal sensor | | 0.1 | | $^{\circ}C$ | |
| External Diode Drive High | | | | 84 | | μA | |
| External Diode Drive Low | | | | 6 | | μA | |
| Diode Drive Current Ratio | | | | 14 | | | |
| DXN_ Impedance to GND | | | | 1.8 | | $k\Omega$ | |
| Power-Supply Rejection | PSR | Internal sensor, DC condition | | 0.1 | | $^{\circ}C/V$ | |
| CURRENT SENSE | | | | | | | |
| CS+ Input Voltage Range | V_{CS+} | | 3 | | 28 | V | |
| Input Bias Current | I_{CS+} | $V_{CS+} = V_{CS-}$ | | 14 | 25 | μA | |
| | I_{CS-} | $V_{CS-} = V_{CS+}$ | | 3 | 8 | | |
| Primary Current-Sense Differential Thresholds | V_{CSTH} | $V_{CS+} - V_{CS-}$ | A = 48 | 21.5 | 25 | 28.5 | mV |
| | | | A = 24 | 45 | 50 | 55 | |
| | | | A = 12 | 92 | 100 | 108 | |
| | | | A = 6 | 190 | 200 | 210 | |
| Primary Current-Sense Threshold | CSHYS | Percent of V_{CSTH} | | 0.5 | | % | |
| Secondary Overcurrent Threshold Timeout | | r5Ch[1:0] = 00 | | 50 | | μs | |
| | | r5Ch[1:0] = 01 | 3.6 | 4 | 4.4 | ms | |
| | | r5Ch[1:0] = 10 | 14.4 | 16 | 17.6 | | |
| | | r5Ch[1:0] = 11 | 57.6 | 64 | 70.4 | | |

EEPROM-Based System Monitors with Nonvolatile Fault Memory

MAX16031/MAX16032

ELECTRICAL CHARACTERISTICS (continued)

($V_{CC} = 2.9V$ to $14V$, $T_A = -40^{\circ}C$ to $+85^{\circ}C$, unless otherwise specified. Typical values are at $V_{CC} = 3.3V$, $T_A = +25^{\circ}C$.) (Note 1)

| PARAMETER | SYMBOL | CONDITIONS | MIN | TYP | MAX | UNITS |
|--|---|--|--------|-----------|-----|---------|
| Current-Sense Analog Input Range | | $V_{CS+} - V_{CS-}$ | A = 6 | 232 | | mV |
| | | | A = 12 | 116 | | |
| | | | A = 24 | 58 | | |
| | | | A = 48 | 29 | | |
| ADC Current-Sense Measurement Accuracy | | $V_{SENSE} = 150mV$ (A = 6 only) | -4 | ± 0.2 | +4 | % |
| | | $V_{SENSE} = 50mV$ (A = 6, 12 only) | -10 | ± 1.2 | +10 | |
| | | $V_{SENSE} = 25mV$ | | ± 2 | | |
| | | $V_{SENSE} = 10mV$ | | ± 10 | | |
| Gain Accuracy | | $V_{SENSE} = 20mV$ to $100mV$, $V_{CS+} = 12V$, A = 6 | -3 | | +3 | % |
| Common-Mode Rejection Ratio | CMRR _{CS} | $V_{CS+} > 4V$ | | 80 | | dB |
| Power-Supply Rejection Ratio | PSRR _{CS} | | | 80 | | dB |
| $\overline{O}VERC$ Output Leakage Current | I _{OVERCLKG} | | | | 1 | μA |
| $\overline{O}VERC$ Output Low Voltage | V _{O$\overline{O}VERC$} | I _{OUT} = 3mA | | | 0.4 | V |
| $\overline{O}VERC$ Propagation Delay | t _{OVERC} | $V_{SENSE} - V_{CSTH} > 10\% \times V_{CSTH}$ | | | 5 | μs |
| SMBus INTERFACE (SCL, SDA) | | | | | | |
| Logic-Input Low Voltage | V _{IL} | Input voltage falling | | | 0.8 | V |
| Logic-Input High Voltage | V _{IH} | Input voltage rising | 2.0 | | | V |
| Input Leakage Current | | GND or 5.5V ($V_{CC} = 5.5V$) V _{SCL} , V _{SDA} | -1 | | +1 | μA |
| Output Low Voltage | V _{OL} | I _{SINK} = 3mA | | | 0.4 | V |
| Input Capacitance | C _{IN} | | | 5 | | pF |
| ALERT, FAULT_, AND GPIO_ OUTPUTS | | | | | | |
| ALERT, FAULT_, and GPIO_ Output Low Voltage | | I _{SINK} = 3mA | | | 0.4 | V |
| ALERT, FAULT_, and GPIO_ Leakage Current | | $V_{\overline{ALERT}}$, $V_{\overline{FAULT_}}$, $V_{GPIO_} = 5.5V$ or GND | -1 | | +1 | μA |
| GPIO_ (INPUT) | | | | | | |
| Logic-Low Voltage | | GPIO_ voltage falling | | | 0.8 | V |
| Logic-High Voltage | | GPIO_ voltage rising | 2.0 | | | V |
| SMBus ADDRESS (A0 and A1) | | | | | | |
| Address Logic-Low | | | | | 0.4 | V |
| Address Logic-High | | | 1.4 | | | V |
| High-Impedance Leakage Current | | Maximum current to achieve high-impedance logic level | -1 | | +1 | μA |
| Input Leakage Current | | 0 to 3V, $V_{CC} = 3V$ | -12 | | +12 | μA |

EEPROM-Based System Monitors with Nonvolatile Fault Memory

ELECTRICAL CHARACTERISTICS (continued)

($V_{CC} = 2.9V$ to $14V$, $T_A = -40^{\circ}C$ to $+85^{\circ}C$, unless otherwise specified. Typical values are at $V_{CC} = 3.3V$, $T_A = +25^{\circ}C$.) (Note 1)

| PARAMETER | SYMBOL | CONDITIONS | MIN | TYP | MAX | UNITS |
|---|---------------|------------------------------------|-----|-----|------|-----------|
| SMBus TIMING (see Figure 1) | | | | | | |
| Serial-Clock Frequency | f_{SCL} | | | | 400 | kHz |
| Bus Free Time Between STOP and START Conditions | t_{BUF} | | 1.3 | | | μs |
| START Condition Setup Time | $t_{SU:STA}$ | | 0.6 | | | μs |
| START Condition Hold Time | $t_{HD:STA}$ | | 0.6 | | | μs |
| STOP Condition Setup Time | $t_{SU:STO}$ | | 0.6 | | | μs |
| Clock Low Period | t_{LOW} | | 1.3 | | | μs |
| Clock High Period | t_{HIGH} | | 0.6 | | | μs |
| Data Setup Time | $t_{SU:DAT}$ | | 100 | | | ns |
| Output Fall Time | t_{OF} | $C_{BUS} = 10pF$ to $400pF$ | | | 250 | ns |
| Data Hold Time | $t_{HD:DAT}$ | From 50% SCL falling to SDA change | 0.3 | | 0.9 | μs |
| Minimum Pulse Width Ignored | | | | 30 | | ns |
| SMBus Timeout | $t_{TIMEOUT}$ | SCL time low for reset | 25 | | 35 | ms |
| JTAG INTERFACE (see Figure 2) | | | | | | |
| TDI, TMS, TCK Logic-Low Input Voltage | V_{IL} | Input voltage falling | | | 0.4 | V |
| TDI, TMS, TCK Logic-High Input Voltage | V_{IH} | Input voltage rising | 2.2 | | | V |
| TDO Logic-Output Low Voltage | V_{OL} | $I_{SINK} = 4mA$ | | | 0.4 | V |
| TDO Logic-Output High Voltage | V_{OH} | $I_{SOURCE} = 1mA$ | 2.2 | | | V |
| TDO Leakage Current | | TDO high impedance | -10 | | +10 | μA |
| TDI, TMS Pullup Resistors | R_{JPU} | Pullup to V_{DBP} | 6.5 | 10 | 16 | $k\Omega$ |
| I/O Capacitance | $C_{I/O}$ | | | 50 | | pF |
| TCK Clock Period | t_1 | | | | 1000 | ns |
| TCK High/Low Time | t_2, t_3 | (Note 3) | 60 | 500 | | ns |
| TCK to TMS, TDI Setup Time | t_4 | | 15 | | | ns |
| TCK to TMS, TDI Hold Time | t_5 | | 35 | | | ns |
| TCK to TDO Delay | t_6 | | | | 500 | ns |
| TCK to TDO High-Impedance Delay | t_7 | | | | 500 | ns |
| MISCELLANEOUS | | | | | | |
| Power-On Delay | t_{D-PO} | | | | 4 | ms |
| Single-Byte EEPROM Write Cycle Delay | | (Note 4) | | | 11 | ms |

Note 1: Limits to $-40^{\circ}C$ are guaranteed by design.

Note 2: Guaranteed by design.

Note 3: TCK stops either high or low.

Note 4: An additional cycle is required when writing to configuration memory for the first time.

EEPROM-Based System Monitors with Nonvolatile Fault Memory

MAX16031/MAX16032

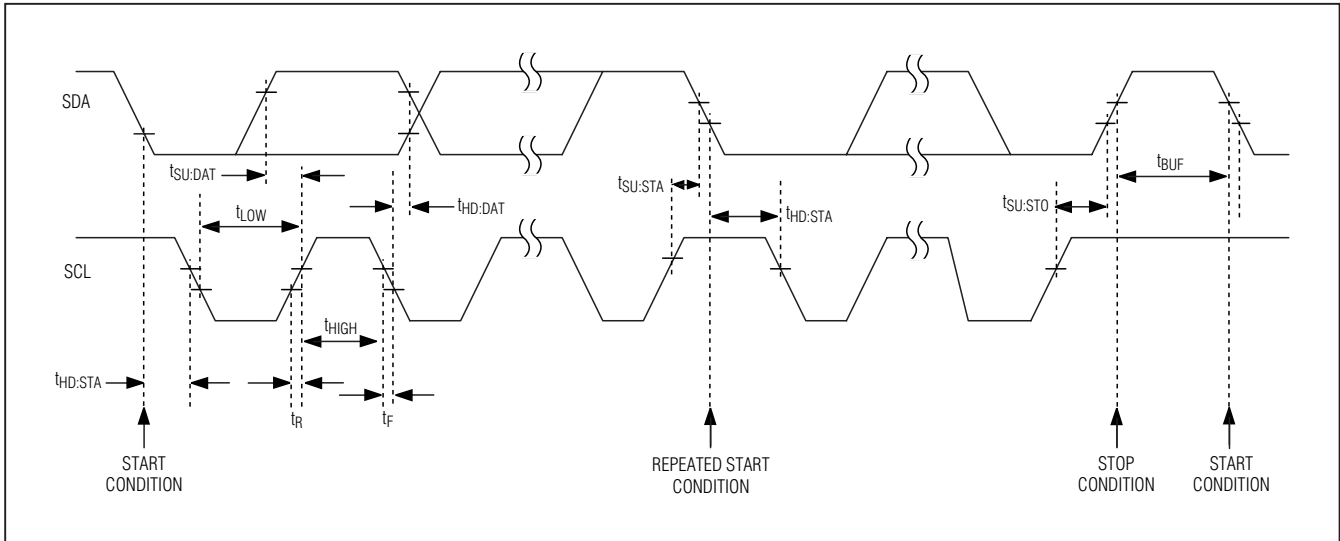

Figure 1. SMBus Interface Timing Diagram

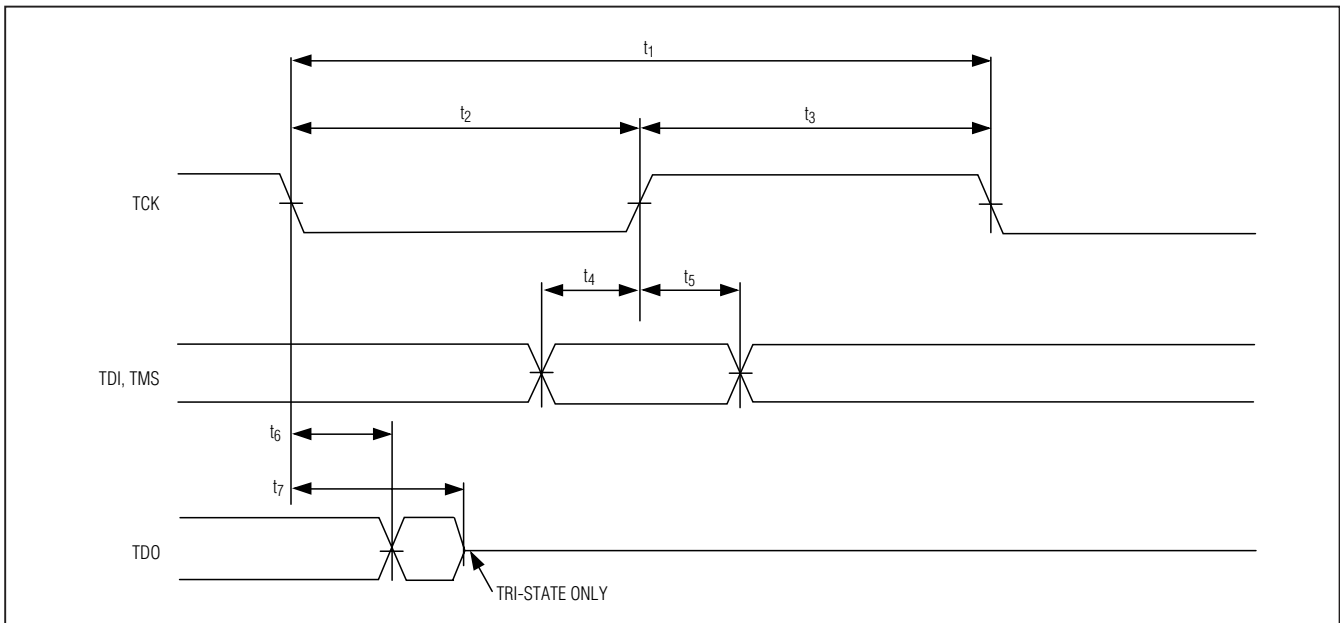
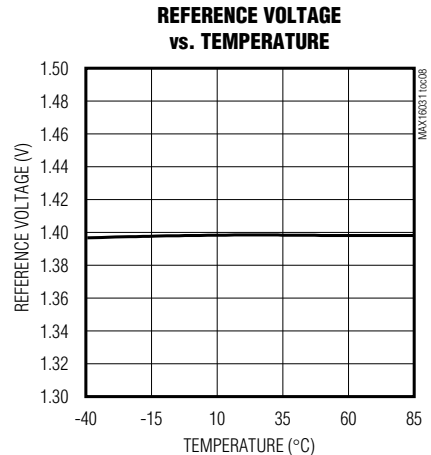
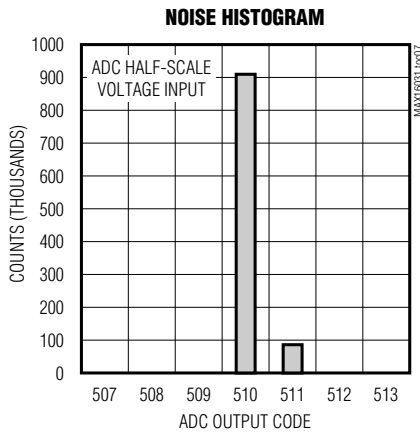
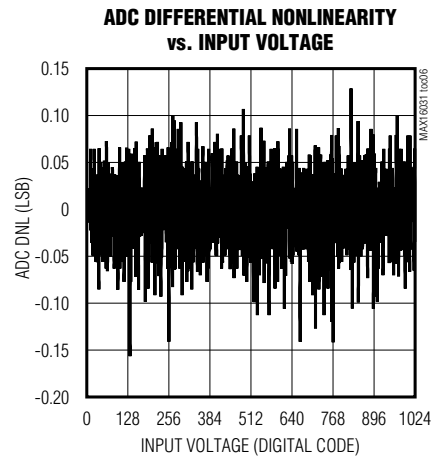
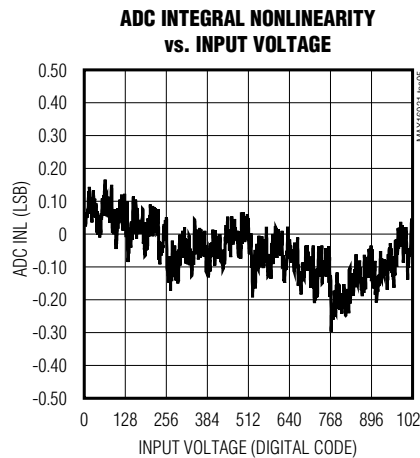
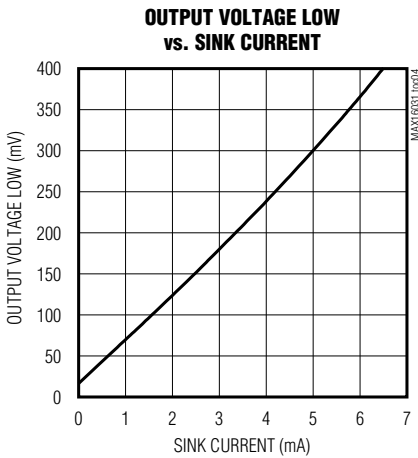
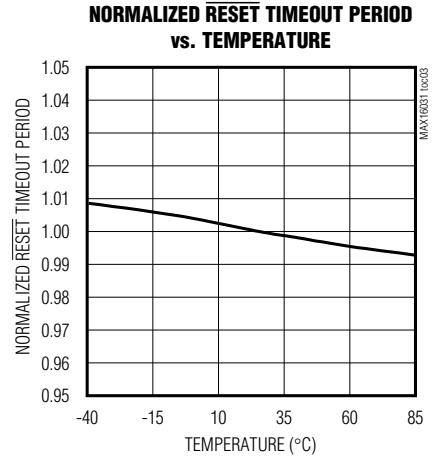
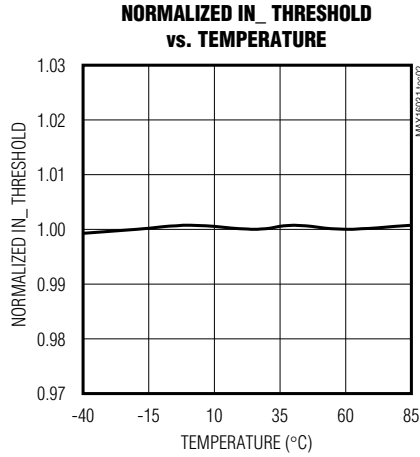
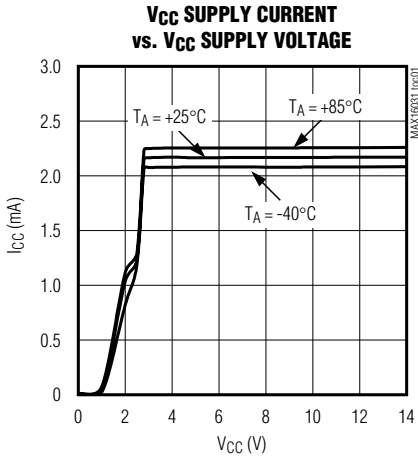

Figure 2. JTAG Interface Timing Diagram

EEPROM-Based System Monitors with Nonvolatile Fault Memory

Typical Operating Characteristics

(Typical values are at $V_{CC} = 3.3V$, $T_A = +25^\circ C$, unless otherwise noted.)



EEPROM-Based System Monitors with Nonvolatile Fault Memory

Typical Operating Characteristics (continued)

(Typical values are at $V_{CC} = 3.3V$, $T_A = +25^\circ C$, unless otherwise noted.)

MAX16031/MAX16032

INTERNAL TEMPERATURE SENSOR ACCURACY vs. TEMPERATURE

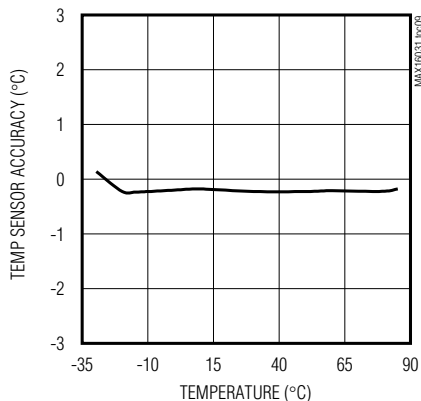

TEMPERATURE ERROR vs. REMOTE DIODE TEMPERATURE

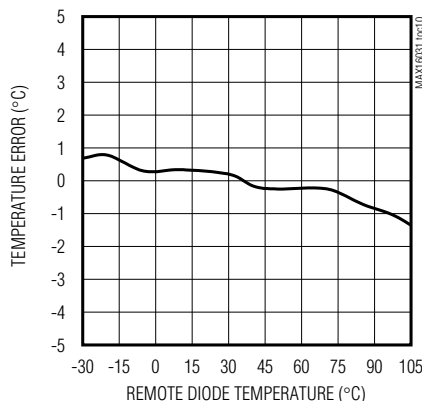

TEMPERATURE ERROR vs. LEAKAGE RESISTANCE

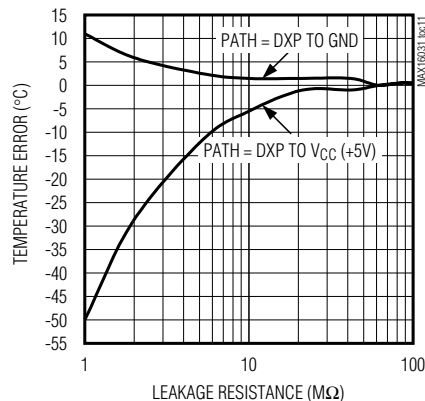

TEMPERATURE ERROR vs. DXP-DXN CAPACITANCE

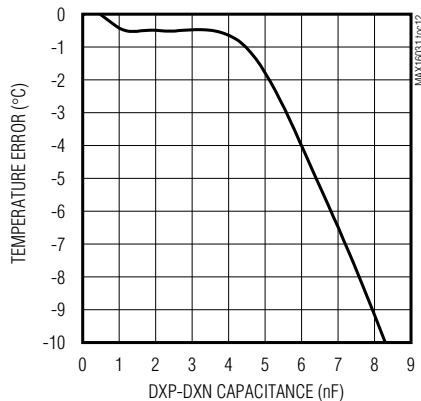

CURRENT-SENSE ACCURACY vs. VSENSE

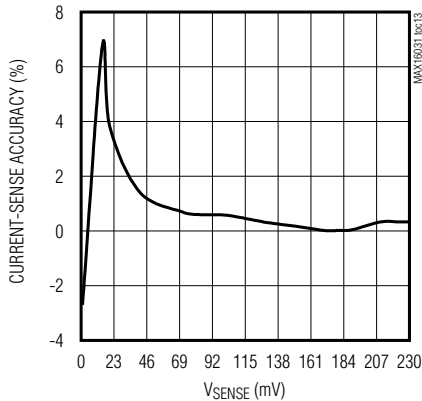

CURRENT-SENSE PRIMARY THRESHOLD vs. VSENSE OVERDRIVE

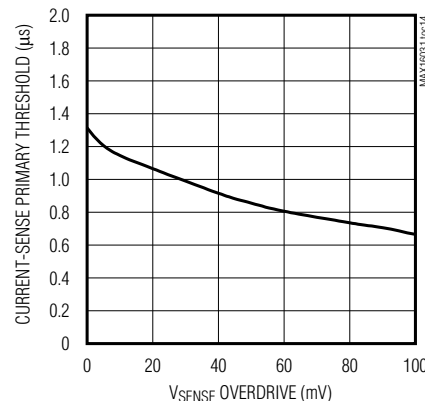

EEPROM-Based System Monitors with Nonvolatile Fault Memory

Pin Description

MAX16031/MAX16032

| PIN | | NAME | FUNCTION |
|-----------------------------|--|-------|---|
| MAX16031 | MAX16032 | | |
| 1 | 1 | IN2 | Supply Monitor Input 2. IN2 is internally sampled by the ADC. It is configurable for unipolar/ bipolar and single-ended/pseudo-differential. In pseudo-differential mode, IN1 and IN2 form the + and - of the differential pair. Each input must stay within the specified ADC IN _v voltage range. |
| 2 | 2 | IN3 | Supply Monitor Input 3. IN3 is internally sampled by the ADC. It is configurable for unipolar/ bipolar and single-ended/pseudo-differential. In pseudo-differential mode, IN3 and IN4 form the + and - of the differential pair. Each input must stay within the specified ADC IN _v voltage range. |
| 3 | 3 | IN4 | Supply Monitor Input 4. IN4 is internally sampled by the ADC. It is configurable for unipolar/ bipolar and single-ended/pseudo-differential. In pseudo-differential mode, IN3 and IN4 form the + and - of the differential pair. Each input must stay within the specified ADC IN _v voltage range. |
| 4–7, 30, 31, 32, 39, 40, 47 | 4–7, 11, 12, 23, 30, 31, 32, 39, 40–44, 47 | N.C. | No Connection. Leave unconnected. Do not use. |
| 8, 13, 35 | 8, 13, 35 | GND | Ground. Connect all GND pins together. |
| 9 | 9 | IN5 | Supply Monitor Input 5. IN5 is internally sampled by the ADC. It is configurable for unipolar/ bipolar and single-ended/pseudo-differential. In pseudo-differential mode, IN5 and IN6 form the + and - of the differential pair. Each input must stay within the specified ADC IN _v voltage range. |
| 10 | 10 | IN6 | Supply Monitor Input 6. IN6 is internally sampled by the ADC. It is configurable for unipolar/ bipolar and single-ended/pseudo-differential. In pseudo-differential mode, IN5 and IN6 form the + and - of the differential pair. Each input must stay within the specified ADC IN _v voltage range. |
| 11 | — | IN7 | Supply Monitor Input 7. IN7 is internally sampled by the ADC. It is configurable for unipolar/ bipolar and single-ended/pseudo-differential. In pseudo-differential mode, IN7 and IN8 form the + and - of the differential pair. Each input must stay within the specified ADC IN _v voltage range. |
| 12 | — | IN8 | Supply Monitor Input 8. IN8 is internally sampled by the ADC. It is configurable for unipolar/ bipolar and single-ended/pseudo-differential. In pseudo-differential mode, IN7 and IN8 form the + and - of the differential pair. Each input must stay within the specified ADC IN _v voltage range. |
| 14 | 14 | GPIO1 | Configurable General-Purpose Input/Output 1 |
| 15 | 15 | GPIO2 | Configurable General-Purpose Input/Output 2 |
| 16 | 16 | RBP | ADC Reference Bypass. RBP is an internally generated 1.4V reference for the ADC. Bypass RBP to GND with a 2.2μF capacitor. Do not use RBP to power any additional circuitry. |
| 17 | 17 | SDA | SMBus Serial-Data, Open-Drain Input/Output |
| 18 | 18 | SCL | SMBus Serial-Clock Input |
| 19 | 19 | A0 | SMBus Address Input 0. Connect to DBP, GND, or leave unconnected to select the desired device address. |
| 20 | 20 | A1 | SMBus Address Input 1. Connect to DBP, GND, or leave unconnected to select the desired device address. |

EEPROM-Based System Monitors with Nonvolatile Fault Memory

Pin Description (continued)

MAX16031/MAX16032

| PIN | | NAME | FUNCTION |
|----------|----------|----------------------------|---|
| MAX16031 | MAX16032 | | |
| 21 | 21 | $\overline{\text{ALERT}}$ | SMBus Alert Open-Drain Output. $\overline{\text{ALERT}}$ follows the SMBALERT# signal functionality described in Appendix A of the SMBus 2.0 Specification. $\overline{\text{ALERT}}$ asserts when the device detects a fault, thereby interrupting the host processor to query which device on the serial bus detected faults. |
| 22 | 22 | $\overline{\text{OVERT}}$ | Overtemperature, Open-Drain Output. $\overline{\text{OVERT}}$ asserts when an overtemperature condition is detected. |
| 23 | — | $\overline{\text{OVERC}}$ | Overcurrent, Open-Drain Output. $\overline{\text{OVERC}}$ asserts when the primary overcurrent threshold is exceeded. |
| 24 | 24 | $\overline{\text{FAULT2}}$ | Configurable Open-Drain Fault Output 2 |
| 25 | 25 | $\overline{\text{FAULT1}}$ | Configurable Open-Drain Fault Output 1 |
| 26 | 26 | $\overline{\text{RESET}}$ | Configurable Open-Drain Reset Output |
| 27 | 27 | TMS | JTAG Test Mode Select Input. Internally pulled up to VDBP with a 10k Ω resistor. |
| 28 | 28 | TCK | JTAG Test Clock Input |
| 29 | 29 | TDI | JTAG Test Data Input. Internally pulled up to VDBP with a 10k Ω resistor. |
| 33 | 33 | TDO | JTAG Test Data Output |
| 34 | 34 | DBP | Internal Digital Voltage Regulator Output. Connect a 1 μ F bypass capacitor from DBP to GND. Do not use DBP to power external circuitry. |
| 36 | 36 | ABP | Internal Analog Voltage Regulator Output. Connect a 1 μ F bypass capacitor from ABP to GND. Do not use ABP to power external circuitry. |
| 37, 38 | 37, 38 | VCC | Device Power Supply. Bypass VCC to GND with a 1 μ F capacitor. |
| 41 | — | CS- | Current-Sense Negative Input. Must be biased between 3V to 28V for proper operation. |
| 42 | — | CS+ | Current-Sense Positive Input. Must be biased between 3V to 28V for proper operation. |
| 43 | — | DXN2 | Remote Diode 2 Negative Input. If remote sensing is not used, connect DXP2 to DXN2. |
| 44 | — | DXP2 | Remote Diode 2 Positive Input. If remote sensing is not used, connect DXP2 to DXN2. |
| 45 | 45 | DXN1 | Remote Diode 1 Negative Input. If remote sensing is not used, connect DXP1 to DXN1. |
| 46 | 46 | DXP1 | Remote Diode 1 Positive Input. If remote sensing is not used, connect DXP1 to DXN1. |
| 48 | 48 | IN1 | Supply Monitor Input 1. IN1 is internally sampled by the ADC. It is configurable for unipolar/bipolar and single-ended/pseudo-differential. In pseudo-differential mode, IN1 and IN2 form the + and - of the differential pair. Each input must stay within the specified ADC IN_ voltage range. |
| — | — | EP | Exposed Pad. Connect EP to ground. EP is internally connected to GND. Do not use as the main ground connection. |

EEPROM-Based System Monitors with Nonvolatile Fault Memory

Functional Diagram

MAX16031/MAX16032

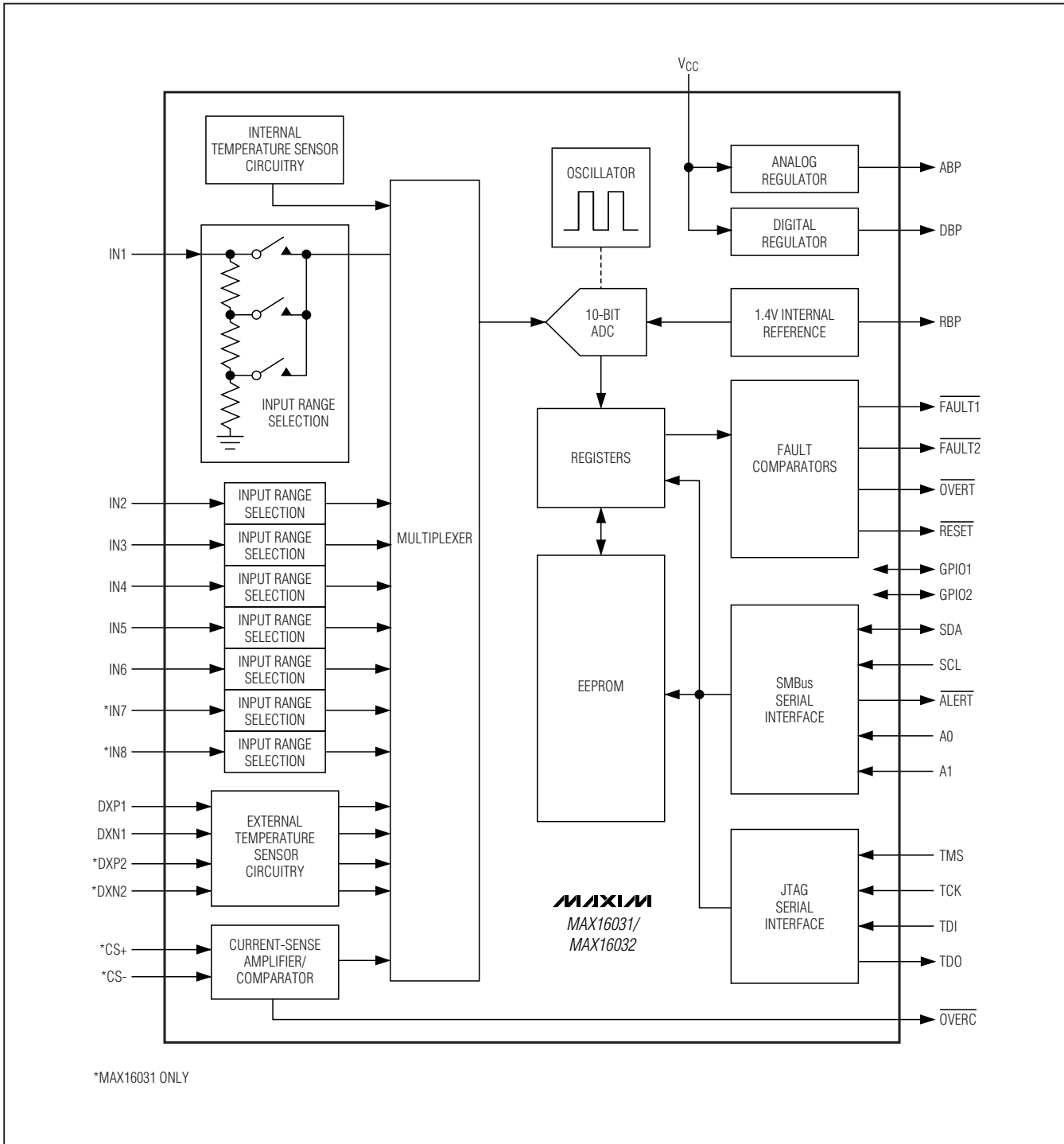

EEPROM-Based System Monitors with Nonvolatile Fault Memory

MAX16031/MAX16032

Table 1. Address Map

| REGISTER ADDRESS | EEPROM MEMORY ADDRESS | READ/ WRITE | DESCRIPTION |
|------------------|-----------------------|-------------|--|
| 00h | — | R | IN1 ADC Result Register (MSB) |
| 01h | — | R | IN1 ADC Result Register (LSB) |
| 02h | — | R | IN2 ADC Result Register (MSB) |
| 03h | — | R | IN2 ADC Result Register (LSB) |
| 04h | — | R | IN3 ADC Result Register (MSB) |
| 05h | — | R | IN3 ADC Result Register (LSB) |
| 06h | — | R | IN4 ADC Result Register (MSB) |
| 07h | — | R | IN4 ADC Result Register (LSB) |
| 08h | — | R | IN5 ADC Result Register (MSB) |
| 09h | — | R | IN5 ADC Result Register (LSB) |
| 0Ah | — | R | IN6 ADC Result Register (MSB) |
| 0Bh | — | R | IN6 ADC Result Register (LSB) |
| 0Ch | — | R | IN7 ADC Result Register (MSB)* |
| 0Dh | — | R | IN7 ADC Result Register (LSB)* |
| 0Eh | — | R | IN8 ADC Result Register (MSB)* |
| 0Fh | — | R | IN8 ADC Result Register (LSB)* |
| 10h | — | R | Internal Temperature Sensor ADC Result Register (MSB) |
| 11h | — | R | Internal Temperature Sensor ADC Result Register (LSB) |
| 12h | — | R | Remote Temperature Sensor 1 ADC Result Register (MSB) |
| 13h | — | R | Remote Temperature Sensor 1 ADC Result Register (LSB) |
| 14h | — | R | Remote Temperature Sensor 2 ADC Result Register (MSB) |
| 15h | — | R | Remote Temperature Sensor 2 ADC Result Register (LSB) |
| 16h | — | R | Current-Sense ADC Result Register |
| 17h | 97h | R/W | Voltage Monitoring Input ADC Range Selection (IN1–IN4) |
| 18h | 98h | R/W | Voltage Monitoring Input ADC Range Selection (IN5–IN8) |
| 19h | 99h | R/W | Current-Sense Gain/Primary Threshold and Remote Temperature Sensor 1 Gain Trim |
| 1Ah | 9Ah | R/W | Voltage Monitoring Input Enable |
| 1Bh | 9Bh | R/W | Internal/Remote Temperature Sensor, Current Sense, and $\overline{\text{ALERT}}$ Enables and Remote Temperature Sensor 1 Offset Trim |
| 1Ch | 9Ch | R/W | Voltage Monitoring Input Single-Ended/Differential and Unipolar/Bipolar Selection |
| 1Dh | 9Dh | R/W | $\overline{\text{FAULT1}}$ Dependency Selection |
| 1Eh | 9Eh | R/W | $\overline{\text{FAULT2}}$ Dependency Selection |
| 1Fh | 9Fh | R/W | $\overline{\text{OVERT}}$ Dependency Selection |
| 20h | A0h | R/W | $\overline{\text{RESET}}$ Dependency and Timeout Selection |
| 21h | A1h | R/W | $\overline{\text{RESET}}$ IN1–IN8 Dependency Selection |
| 22h | A2h | R/W | GPIO1 Configuration |
| 23h | A3h | R/W | GPIO1 Dependency Selection |
| 24h | A4h | R/W | GPIO2 Configuration |

EEPROM-Based System Monitors with Nonvolatile Fault Memory

MAX16031/MAX16032

Table 1. Address Map (continued)

| REGISTER ADDRESS | EEPROM MEMORY ADDRESS | READ/ WRITE | DESCRIPTION |
|------------------|-----------------------|-------------|---|
| 25h | A5h | R/W | GPIO2 Dependency Selection |
| 26h | A6h | R/W | IN1 Primary Undervoltage Threshold |
| 27h | A7h | R/W | IN1 Primary Overvoltage Threshold |
| 28h | A8h | R/W | IN1 Secondary Undervoltage Threshold |
| 29h | A9h | R/W | IN1 Secondary Overvoltage Threshold |
| 2Ah | AAh | R/W | IN2 Primary Undervoltage Threshold |
| 2Bh | ABh | R/W | IN2 Primary Overvoltage Threshold |
| 2Ch | ACh | R/W | IN2 Secondary Undervoltage Threshold |
| 2Dh | ADh | R/W | IN2 Secondary Overvoltage Threshold |
| 2Eh | A Eh | R/W | IN3 Primary Undervoltage Threshold |
| 2Fh | AFh | R/W | IN3 Primary Overvoltage Threshold |
| 30h | B0h | R/W | IN3 Secondary Undervoltage Threshold |
| 31h | B1h | R/W | IN3 Secondary Overvoltage Threshold |
| 32h | B2h | R/W | IN4 Primary Undervoltage Threshold |
| 33h | B3h | R/W | IN4 Primary Overvoltage Threshold |
| 34h | B4h | R/W | IN4 Secondary Undervoltage Threshold |
| 35h | B5h | R/W | IN4 Secondary Overvoltage Threshold |
| 36h | B6h | R/W | IN5 Primary Undervoltage Threshold |
| 37h | B7h | R/W | IN5 Primary Overvoltage Threshold |
| 38h | B8h | R/W | IN5 Secondary Undervoltage Threshold |
| 39h | B9h | R/W | IN5 Secondary Overvoltage Threshold |
| 3Ah | BAh | R/W | IN6 Primary Undervoltage Threshold |
| 3Bh | BBh | R/W | IN6 Primary Overvoltage Threshold |
| 3Ch | BCh | R/W | IN6 Secondary Undervoltage Threshold |
| 3Dh | BDh | R/W | IN6 Secondary Overvoltage Threshold |
| 3Eh | BEh | R/W | IN7 Primary Undervoltage Threshold* |
| 3Fh | BFh | R/W | IN7 Primary Overvoltage Threshold* |
| 40h | C0h | R/W | IN7 Secondary Undervoltage Threshold* |
| 41h | C1h | R/W | IN7 Secondary Overvoltage Threshold* |
| 42h | C2h | R/W | IN8 Primary Undervoltage Threshold* |
| 43h | C3h | R/W | IN8 Primary Overvoltage Threshold* |
| 44h | C4h | R/W | IN8 Secondary Undervoltage Threshold* |
| 45h | C5h | R/W | IN8 Secondary Overvoltage Threshold* |
| 46h | C6h | R/W | Internal Temperature Sensor Primary Overtemperature Threshold (MSB) |
| 47h | C7h | R/W | Internal Temperature Sensor Secondary Overtemperature Threshold (MSB) |
| 48h | C8h | R/W | Remote Temperature Sensor 1 Primary Overtemperature Threshold |
| 49h | C9h | R/W | Remote Temperature Sensor 1 Secondary Overtemperature Threshold |
| 4Ah | CAh | R/W | Remote Temperature Sensor 2 Primary Overtemperature Threshold |

EEPROM-Based System Monitors with Nonvolatile Fault Memory

MAX16031/MAX16032

Table 1. Address Map (continued)

| REGISTER ADDRESS | EEPROM MEMORY ADDRESS | READ/ WRITE | DESCRIPTION |
|------------------|-----------------------|-------------|---|
| 4Bh | CBh | R/W | Remote Temperature Sensor 2 Secondary Overtemperature Threshold |
| 4Ch | CCh | R/W | Overcurrent Secondary Threshold |
| 4Dh | CDh | R/W | Remote Temperature Sensor Primary/Secondary Overtemperature Threshold (LSBs). External Temperature Sensor 2 Offset Trim |
| 4Eh | CEh | R/W | Remote Temperature Sensor 1/2 Primary/Secondary Overtemperature Threshold (LSBs) |
| 4Fh | CFh | R/W | Remote Temperature Sensor 2 Gain Trim |
| 50h | D0h | R/W | Remote Temperature Sensor Short/Open Status |
| 51h | D1h | R/W | IN1–IN8 Primary Threshold Fault Status |
| 52h | D2h | R/W | IN1–IN8 Secondary Threshold Fault Status |
| 53h | D3h | R/W | Temperature/Current Threshold Fault Status |
| 54h | D4h | R/W | Remote Temperature Sensor Short/Open Fault Mask |
| 55h | D5h | R/W | IN1–IN8 Primary Threshold Fault Mask |
| 56h | D6h | R/W | IN1–IN8 Secondary Threshold Fault Mask |
| 57h | D7h | R/W | Temperature/Current Threshold Fault Mask |
| 58h | D8h | R/W | IN1–IN8 Primary Undervoltage Faults Triggering Fault EEPROM |
| 59h | D9h | R/W | IN1–IN8 Primary Overvoltage Faults Triggering Fault EEPROM |
| 5Ah | DAh | R/W | Temperature/Current Faults Triggering Fault EEPROM |
| 5Bh | DBh | R/W | Temperature Filter Selection and Postboot Fault Mask Time |
| 5Ch | DCh | R/W | Threshold Fault Options and Overcurrent Fault Timeout |
| 5Dh | DDh | — | Reserved |
| 5Eh | DEh | R/W | Customer Firmware Version |
| 5Fh | DFh | R/W | EEPROM and Configuration Lock |
| 60h–7Fh | E0h–FFh | — | Reserved |
| — | 80h | R | IN1–IN8 Primary Threshold Fault Status at Time of Fault |
| — | 81h | R | IN1–IN8 Secondary Threshold Fault Status at Time of Fault |
| — | 82h | R | Temperature/Current Threshold Fault Status at Time of Fault |
| — | 83h | R | IN1 Conversion Result at Time of Fault |
| — | 84h | R | IN2 Conversion Result at Time of Fault |
| — | 85h | R | IN3 Conversion Result at Time of Fault |
| — | 86h | R | IN4 Conversion Result at Time of Fault |
| — | 87h | R | IN5 Conversion Result at Time of Fault |
| — | 88h | R | IN6 Conversion Result at Time of Fault |
| — | 89h | R | IN7 Conversion Result at Time of Fault* |
| — | 8Ah | R | IN8 Conversion Result at Time of Fault* |
| — | 8Bh | R | Internal Temperature Sensor Conversion Result at Time of Fault |
| — | 8Ch | R | Remote Temperature Sensor 1 Conversion Result at Time of Fault |
| — | 8Dh | R | Remote Temperature Sensor 2 Conversion Result at Time of Fault* |
| — | 8Eh | R | Current-Sense Conversion Result at Time of Fault* |

*MAX16031 only.

EEPROM-Based System Monitors with Nonvolatile Fault Memory

Detailed Description

Getting Started

The MAX16031/MAX16032 contain both I²C/SMBus and JTAG serial interfaces for accessing registers and EEPROM. Use only one interface at any given time. For more information on how to access the internal memory through these interfaces, see the *I²C/SMBus-Compatible Serial Interface* and *JTAG Serial Interface* sections. This data sheet uses a specific convention for referring to bits within a particular address location. As an example, r15h[3:0] refers to bits 3 through 0 in register with address 15 hexadecimal.

The factory-default values at power-on reset (POR) for all EEPROM locations are zeros. POR occurs when V_{CC} reaches the undervoltage lockout (UVLO) of 2.8V. At POR, the device begins a boot-up sequence. During the boot-up sequence, all monitored inputs are masked from initiating faults and EEPROM contents are copied to the respective register locations. The boot-up sequence takes up to 1.81ms. Monitoring is disabled for up to 16s past the boot-up sequence by programming r5Bh[3:0] (see the *Miscellaneous Settings* section). RESET is low during boot-up and remains low after boot-up for its programmed timeout period after all monitored channels are within their respective thresholds.

The MAX16031/MAX16032 monitor up to eight voltages, up to one current, and up to three temperatures. After boot-up, an internal multiplexer cycles through each input. At each multiplexer stop, the 10-bit ADC converts the analog parameter to a digital result and stores the result in a register. Each time the multiplexer completes a cycle, internal logic compares the conversion results to the thresholds stored in memory. When a conversion vio-

lates a programmed threshold, the conversion is configured to generate a fault. Logic outputs are programmed to depend on many combinations of faults. Additionally, faults are programmed to trigger a fault log, whereby all fault information is automatically written to EEPROM.

Voltage Monitoring

The MAX16031 provides eight inputs, IN1–IN8, for voltage monitoring. The MAX16032 provides six inputs, IN1–IN6, for voltage monitoring. Each input voltage range is programmable through r17h[7:0] and r18h[7:0] (see Table 2). Voltage monitoring for each input is enabled through r1Ah[7:0] (see Table 2). There are four programmable thresholds per voltage monitor input: primary undervoltage, secondary undervoltage, primary overvoltage, and secondary overvoltage. All voltage thresholds are 8 bits wide. Only the 8 most significant bits of the conversion result are compared to the thresholds. See the *Miscellaneous Settings* section to set the amount of hysteresis for the thresholds. See Table 1 for an address map of all voltage monitor input threshold registers.

ADC inputs are configurable for two different modes: pseudo-differential and single-ended (see Table 3). In pseudo-differential mode, two inputs make up a differential pair. Pseudo-differential conversions are performed by taking a single-ended conversion at each input of a differential pair and then subtracting the results. The pseudo-differential mode is selectable for unipolar or bipolar operation. Unipolar differential operation allows only positive polarities of differential voltages. Bipolar differential operation allows negative and positive polarities of differential voltages. Bipolar conversions are in two's complement format. For example,

Table 2. Input Monitor Ranges and Enables

| REGISTER ADDRESS | EEPROM MEMORY ADDRESS | BIT RANGE | DESCRIPTION |
|------------------|-----------------------|-----------|---|
| 17h | 97h | [1:0] | IN1 Voltage Range Selection: 00 = 5.6V, 01 = 2.8V 10 = 1.4V, 11 = Reserved |
| | | [3:2] | IN2 Voltage Range Selection: 00 = 5.6V, 01 = 2.8V 10 = 1.4V, 11 = Reserved |
| | | [5:4] | IN3 Voltage Range Selection: 00 = 5.6V, 01 = 2.8V 10 = 1.4V, 11 = Reserved |
| | | [7:6] | IN4 Voltage Range Selection: 00 = 5.6V, 01 = 2.8V 10 = 1.4V, 11 = Reserved |

EEPROM-Based System Monitors with Nonvolatile Fault Memory

MAX16031/MAX16032

Table 2. Input Monitor Ranges and Enables (continued)

| REGISTER ADDRESS | EEPROM MEMORY ADDRESS | BIT RANGE | DESCRIPTION |
|------------------|-----------------------|-----------|--|
| 18h | 98h | [1:0] | IN5 Voltage Range Selection: 00 = 5.6V, 01 = 2.8V 10 = 1.4V, 11 = Reserved |
| | | [3:2] | IN6 Voltage Range Selection: 00 = 5.6V, 01 = 2.8V 10 = 1.4V, 11 = Reserved |
| | | [5:4] | IN7 Voltage Range Selection: 00 = 5.6V, 01 = 2.8V 10 = 1.4V, 11 = Reserved |
| | | [7:6] | IN8 Voltage Range Selection: 00 = 5.6V, 01 = 2.8V 10 = 1.4V, 11 = Reserved |
| 1Ah | 9Ah | [0] | IN1 Monitoring Enable: 0 = IN1 monitoring disabled 1 = IN1 monitoring enabled |
| | | [1] | IN2 Monitoring Enable: 0 = IN2 monitoring disabled 1 = IN2 monitoring enabled |
| | | [2] | IN3 Monitoring Enable: 0 = IN3 monitoring disabled 1 = IN3 monitoring enabled |
| | | [3] | IN4 Monitoring Enable: 0 = IN4 monitoring disabled 1 = IN4 monitoring enabled |
| | | [4] | IN5 Monitoring Enable: 0 = IN5 monitoring disabled 1 = IN5 monitoring enabled |
| | | [5] | IN6 Monitoring Enable: 0 = IN6 monitoring disabled 1 = IN6 monitoring enabled |
| | | [6] | IN7 Monitoring Enable: 0 = IN7 monitoring disabled 1 = IN7 monitoring enabled |
| | | [7] | IN8 Monitoring Enable: 0 = IN8 monitoring disabled 1 = IN8 monitoring enabled |

EEPROM-Based System Monitors with Nonvolatile Fault Memory

a -1V differential input (range of 5.6V) gives a decimal code of -183, which is 1101001001 in two's complement binary form. In single-ended mode, conversions are performed between a single input and ground. When single-ended mode is selected, conversions are always unipolar regardless of r1Ch[7:4]. The single-ended and pseudo-differential ADC mode equations are shown below.

Unipolar single-ended mode:

$$X_{ADC} = \text{INT} \left(\frac{V_{IN-}}{V_{RANGE}} \times 1024 \right)$$

where X_{ADC} is the resulting code in decimal, V_{IN-} is the voltage at a voltage monitoring input, and V_{RANGE} is the selected range programmed in r17h and r18h.

Bipolar/unipolar pseudo-differential mode:

$$X_{ADC} = \text{INT} \left(\frac{V_{IN+}}{V_{RANGE}} \times 1024 \right) - \text{INT} \left(\frac{V_{IN-}}{V_{RANGE}} \times 1024 \right)$$

where X_{ADC} is the resulting code in decimal, V_{IN+} is the voltage at a positive input of a differential voltage monitoring input pair, V_{IN-} is the voltage at a negative input of a differential voltage monitoring input pair, and V_{RANGE} is the selected ADC IN_{-} voltage range programmed in r17h and r18h.

Table 3. IN1–IN8 ADC Input Mode Selection

| REGISTER ADDRESS | EEPROM MEMORY ADDRESS | BIT RANGE | DESCRIPTION |
|------------------|-----------------------|-----------|--|
| 1Ch | 9Ch | [0] | IN1/IN2 Single-Ended/Pseudo-Differential: 0 = IN1 and IN2 conversions are single-ended. 1 = IN1 and IN2 conversions are pseudo-differential (IN1 to IN2). |
| | | [1] | IN3/IN4 Single-Ended/Pseudo-Differential: 0 = IN3 and IN4 conversions are single-ended. 1 = IN3 and IN4 conversions are pseudo-differential (IN3 to IN4). |
| | | [2] | IN5/IN6 Single-Ended/Pseudo-Differential: 0 = IN5 and IN6 conversions are single-ended. 1 = IN5 and IN6 conversions are pseudo-differential (IN5 to IN6). |
| | | [3] | IN7/IN8 Single-Ended/Pseudo-Differential: 0 = IN7 and IN8 conversions are single-ended. 1 = IN7 and IN8 conversions are pseudo-differential (IN7 to IN8). |
| | | [4] | IN1/IN2 Unipolar/Bipolar: 0 = IN1 and IN2 conversions are unipolar. 1 = IN1 and IN2 conversions are bipolar (two's complement). |
| | | [5] | IN3/IN4 Unipolar/Bipolar: 0 = IN3 and IN4 conversions are unipolar. 1 = IN3 and IN4 conversions are bipolar (two's complement). |
| | | [6] | IN5/IN6 Unipolar/Bipolar: 0 = IN5 and IN6 conversions are unipolar. 1 = IN5 and IN6 conversions are bipolar (two's complement). |
| | | [7] | IN7/IN8 Unipolar/Bipolar: 0 = IN7 and IN8 conversions are unipolar. 1 = IN7 and IN8 conversions are bipolar (two's complement). |

EEPROM-Based System Monitors with Nonvolatile Fault Memory

Current Monitoring

The MAX16031 provides current-sense inputs CS+/CS- and a current-sense amplifier for current monitoring (see Figure 3). There are two programmable current-sense thresholds: primary overcurrent and secondary overcurrent. For fast fault detection, the primary overcurrent threshold is implemented with an analog comparator connected to the $\overline{\text{OVERC}}$ output. The primary threshold equation is:

$$I_{\text{TH}} = \frac{V_{\text{CSTH}}}{R_{\text{SENSE}}}$$

where I_{TH} is the current threshold to be set, V_{CSTH} is the threshold set by r19h[1:0], and R_{SENSE} is the value

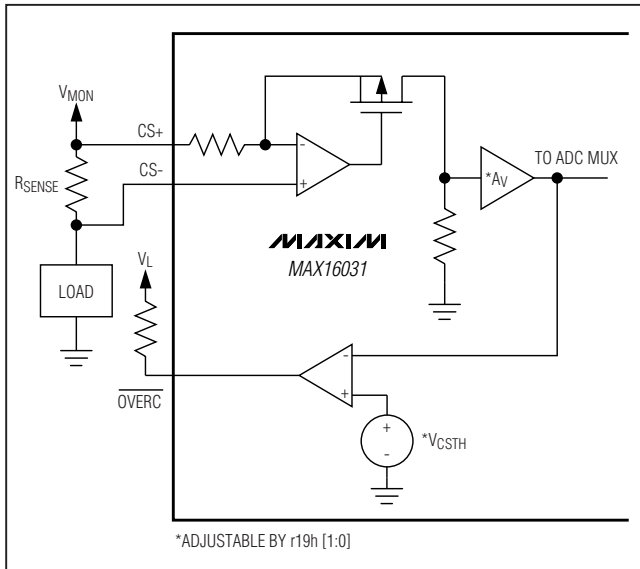

Figure 3. Current-Sense Block Diagram

of the sense resistor. See Table 4 for a description of r19h. The ADC output for a current-sense conversion is:

$$X_{\text{ADC}} = \frac{V_{\text{SENSE}} \times A_v}{V_{\text{RBP}}} \times (2^8 - 1)$$

where X_{ADC} is the 8-bit decimal ADC result, V_{SENSE} is $V_{\text{CS+}} - V_{\text{CS-}}$, A_v is the current-sense voltage gain set by r19h[1:0], and V_{RBP} is the reference voltage at RBP (1.4V typical).

$\overline{\text{OVERC}}$ is latched when the primary overcurrent threshold is exceeded by programming r5Ch[2]. The latch is cleared by writing a '1' to r53h[6]. $\overline{\text{OVERC}}$ depends only on the primary overcurrent threshold. Other fault outputs are programmed to depend on the secondary overcurrent threshold. The secondary overcurrent threshold is implemented through ADC conversions and digital comparisons. The secondary overcurrent threshold contains programmable time delay options located in r5Ch[1:0]. Primary and secondary current-sense faults are enabled/disabled through r1Bh[3].

Temperature Monitoring

The MAX16031 provides two sets of remote diode inputs, DXP1/DXN1 and DXP2/DXN2, and one internal temperature sensor. The MAX16032 provides one set, DXP1/DXN1, and one internal temperature sensor. Calibration registers provide adjustments for gain and offset to accommodate different types of remote diodes. The internal temperature sensor circuitry is factory trimmed. In addition to offset/gain trimming, a programmable lowpass filter is provided. See Figure 4 for the block diagram of the temperature sensor circuitry. The remote diode is actually a diode-connected transistor. See Application Notes AN1057 and AN1944 for information on error budget and several transistor manufacturers.

Table 4. Overcurrent Primary Threshold and Remote Temperature Sense Gain Trim

| REGISTER ADDRESS | EEPROM MEMORY ADDRESS | BIT RANGE | DESCRIPTION |
|------------------|-----------------------|-----------|--|
| 19h | 99h | [1:0] | Overcurrent Primary Threshold and Current-Sense Gain Setting: 00 = 200mV threshold, $A_v = 6V/V$ 01 = 100mV threshold, $A_v = 12V/V$ 10 = 50mV threshold, $A_v = 24V/V$ 11 = 25mV threshold, $A_v = 48V/V$ |
| | | [7:2] | Remote Temperature Sensor 1 Gain Trim. Note bit 6 is inverted. |
| 4Fh | CFh | [5:0] | Remote Temperature Sensor 1 Gain Trim |
| | | [7:6] | Not used |

EEPROM-Based System Monitors with Nonvolatile Fault Memory

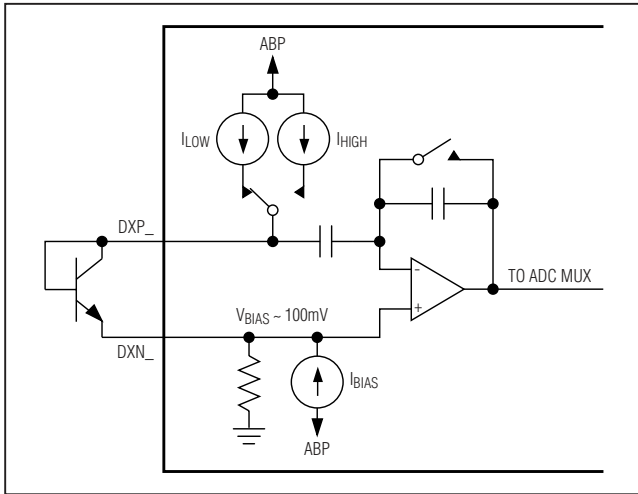

Figure 4. Remote Temperature Sensor Amplifier Circuitry

The ADC converts the internal sensor and remote sensor amplifier outputs. Each time the ADC converts all enabled parameters, the temperature conversions are compared to the temperature threshold registers (r46h to r4Bh and r4Dh). Unlike the voltage input comparators, the temperature threshold comparators are 10 bits wide. $\overline{\text{OVERT}}$ is the designated output for temperature faults, although other outputs are programmed to depend on temperature faults as well. See the *Programmable Inputs/Outputs* section for more information on programming output dependencies. See the *Faults* section for more information on setting temperature fault thresholds.

The remote temperature sensor amplifier detects a short or open between DXP_ and DXN_. The detection of these events is programmed to cause a fault. Temperature thresholds and conversions are in a two's complement temperature format, where 1 LSB corresponds to 0.5°C. The data format for temperature conversions is illustrated in Table 5.

Offset and gain errors for remote temperature sensor measurements are user-trimmed through gain registers r19h[7:2]/r4Fh[5:0] and offset registers r1Bh[7:5]/r4Dh[6:4], as shown in Tables 4 and 6. The gain value trims the high (56µA) drive current source to compensate for the n-factor of the remote diode. The offset value is multiplied by 4 and added to the conversion result numerically. The MAX16031/MAX16032 contain an internal lowpass filter at DXN_ and DXP_ to reduce noise. See the *Miscellaneous Settings* section for more information on programming the filter cutoff frequency.

Table 5. Temperature Data Format

| TEMPERATURE (°C) | DIGITAL CODE |
|------------------|--------------|
| +128 | 1100000000 |
| +125 | 1011111010 |
| +100 | 1011010000 |
| +25.5 | 1000110011 |
| 0 | 1000000000 |
| -10 | 0111101100 |
| -75 | 0101101010 |
| -100 | 0100111000 |
| -128 | 0100000000 |
| Diode fault | 0000000000 |

Reading ADC Results

ADC conversion results are read from the ADC conversion registers through the I²C/SMBus-compatible or JTAG interfaces (see Table 7). These registers are also used for fault threshold comparison. Voltage monitoring thresholds are compared with only the first 8 MSBs of the conversion results.

Programmable Inputs/Outputs

The MAX16031 provides two general fault outputs, $\overline{\text{FAULT1}}$ and $\overline{\text{FAULT2}}$, one reset output $\overline{\text{RESET}}$, one temperature fault output $\overline{\text{OVERT}}$, one current fault output $\overline{\text{OVERC}}$, two general-purpose inputs/outputs GPIO1 and GPIO2, and one SMBALERT#-compatible output $\overline{\text{ALERT}}$. The MAX16032 provides the same except $\overline{\text{OVERC}}$. All outputs are open drain and require pullup resistors. Fault outputs do not latch except for $\overline{\text{OVERC}}$, which either latches or does not latch depending on the configuration bit in r5Ch. Individual fault flag bits, however, latch (see the *Faults* section) and must be cleared one bit at a time by writing a byte containing all zeros except for a single '1' in the bit to be cleared.

The general outputs, $\overline{\text{FAULT1}}$ and $\overline{\text{FAULT2}}$, are identical in functionality and are programmed to depend on overvoltage, undervoltage, overtemperature, and overcurrent parameters. See r1Dh and r1Eh in Table 8 for more detailed information regarding the general fault output dependencies.

The reset output $\overline{\text{RESET}}$ provides many programmable output dependencies as well as reset timeouts. See r20h and r21h in Table 8 for detailed information on $\overline{\text{RESET}}$ output dependencies and timeouts.

The temperature fault output $\overline{\text{OVERT}}$ indicates temperature-related faults. $\overline{\text{OVERT}}$ is programmed to depend on any primary temperature threshold and/or the remote diode open/short flags. $\overline{\text{OVERT}}$ latches low dur-

EEPROM-Based System Monitors with Nonvolatile Fault Memory

MAX16031/MAX16032

Table 6. Temperature Sensor Fault Enable, Current-Sense Fault Enable, SMBALERT# Enable, and Temperature Offset Trim

| REGISTER ADDRESS | EEPROM MEMORY ADDRESS | BIT RANGE | DESCRIPTION |
|------------------|-----------------------|-----------|--|
| 1Bh | 9Bh | [0] | Internal Temperature Sensor Faults Enable: 0 = Internal temperature sensor faults disabled 1 = Internal temperature sensor faults enabled |
| | | [1] | Remote Temperature Sensor 1 Faults Enable: 0 = Remote temperature sensor 1 faults disabled 1 = Remote temperature sensor 1 faults enabled |
| | | [2] | Remote Temperature Sensor 2 Faults Enable: 0 = Remote temperature sensor 2 faults disabled 1 = Remote temperature sensor 2 faults enabled |
| | | [3] | Current-Sense Fault Enable: 0 = Current-sense faults disabled 1 = Current-sense faults enabled |
| | | [4] | SMBALERT# Enable ($\overline{\text{ALERT}}$): 0 = SMBALERT# disabled 1 = SMBALERT# enabled |
| | | [7:5] | Remote Temperature Sensor 1 Offset Trim: Offset = 4 × X, where X is the two's-complement 3-bit temperature code (1 LSB = 0.5°C). Since X is multiplied by 4, the offset LSB size is 2°C, allowing a total offset adjustment of ±6°C. |
| 4Dh | CDh | [1:0] | Internal Temperature Sensor Primary Overtemperature Threshold LSB |
| | | [3:2] | Internal Temperature Sensor Secondary Overtemperature Threshold LSB |
| | | [6:4] | Remote Temperature Sensor 2 Offset Trim: Offset = 4 × X, where X is the two's-complement 3-bit temperature code (1 LSB = 0.5°C). Since X is multiplied by 4, the offset LSB size is 2°C, allowing a total offset adjustment of ±6°C. |
| | | [7] | Not used. |

ing diode open/short fault conditions, and the corresponding diode open/short flags must be cleared to release the latch. See r1Fh in Table 8 for more information on $\overline{\text{OVERT}}$ output dependencies.

The current fault output $\overline{\text{OVERC}}$ indicates overcurrent events. $\overline{\text{OVERC}}$ only depends on the primary analog overcurrent threshold. See the *Current Monitoring* section for more information about the current-sense amplifier and the primary threshold. The secondary overcurrent threshold is set digitally and is used by other outputs. The secondary threshold also has a programmable time-out option (see *Miscellaneous Settings* section).

GPIO1 and GPIO2 are programmable as logic inputs, manual reset inputs, logic outputs, or fault dependent

outputs. See r22h–r25h in Table 8 for more detailed information on GPIO1/GPIO2 functionality. GPIO1 and GPIO2 assert low when configured as a fault output.

$\overline{\text{ALERT}}$ is an SMBALERT#-compatible fault interrupt output. When enabled, it is logically ANDed with outputs RESET, FAULT1, FAULT2, $\overline{\text{OVERT}}$, $\overline{\text{OVERC}}$, and GPIO1/GPIO2 (only if enabled as fault outputs). When any fault output is asserted, ALERT also asserts, interrupting the SMBus master to query the fault. The master needs to answer MAX16031/MAX16032 with a specific SMBus command (ARA) to retrieve the slave address of the interrupting device. See the *I²C/SMBus-Compatible Serial Interface* section for more details.

EEPROM-Based System Monitors with Nonvolatile Fault Memory

Table 7. ADC Conversion Registers

| REGISTER ADDRESS | EEPROM MEMORY ADDRESS | BIT RANGE | DESCRIPTION |
|------------------|-----------------------|-----------|---|
| 00h | — | [7:0] | IN1 ADC Conversion Result (MSB) |
| 01h | — | [1:0] | IN1 ADC Conversion Result (LSB) |
| | | [7:2] | Reserved |
| 02h | — | [7:0] | IN2 ADC Conversion Result (MSB) |
| 03h | — | [1:0] | IN2 ADC Conversion Result (LSB) |
| | | [7:2] | Reserved |
| 04h | — | [7:0] | IN3 ADC Conversion Result (MSB) |
| 05h | — | [1:0] | IN3 ADC Conversion Result (LSB) |
| | | [7:2] | Reserved |
| 06h | — | [7:0] | IN4 ADC Conversion Result (MSB) |
| 07h | — | [1:0] | IN4 ADC Conversion Result (LSB) |
| | | [7:2] | Reserved |
| 08h | — | [7:0] | IN5 ADC Conversion Result (MSB) |
| 09h | — | [1:0] | IN5 ADC Conversion Result (LSB) |
| | | [7:2] | Reserved |
| 0Ah | — | [7:0] | IN6 ADC Conversion Result (MSB) |
| 0Bh | — | [1:0] | IN6 ADC Conversion Result (LSB) |
| | | [7:2] | Reserved |
| 0Ch | — | [7:0] | IN7 ADC Conversion Result (MSB) |
| 0Dh | — | [1:0] | IN7 ADC Conversion Result (LSB) |
| | | [7:2] | Reserved |
| 0Eh | — | [7:0] | IN8 ADC Conversion Result (MSB) |
| 0Fh | — | [1:0] | IN8 ADC Conversion Result (LSB) |
| | | [7:2] | Reserved |
| 10h | — | [7:0] | Internal Temperature Sensor ADC Conversion Result (MSB) |
| 11h | — | [1:0] | Internal Temperature Sensor ADC Conversion Result (LSB) |
| | | [7:2] | Reserved |
| 12h | — | [7:0] | Remote Temperature Sensor 1 ADC Conversion Result (MSB) |
| 13h | — | [1:0] | Remote Temperature Sensor 1 ADC Conversion Result (LSB) |
| | | [7:2] | Reserved |
| 14h | — | [7:0] | Remote Temperature Sensor 2 ADC Conversion Result (MSB) |
| 15h | — | [1:0] | Remote Temperature Sensor 2 ADC Conversion Result (LSB) |
| | | [7:2] | Reserved |
| 16h | — | [7:0] | Current-Sense ADC Conversion Result |

EEPROM-Based System Monitors with Nonvolatile Fault Memory

MAX16031/MAX16032

Table 8. Output Dependencies

| REGISTER ADDRESS | EEPROM MEMORY ADDRESS | BIT RANGE | DESCRIPTION |
|------------------|-----------------------|-----------|---|
| 1Dh | 9Dh | [0] | 1 = $\overline{\text{FAULT1}}$ depends on the secondary undervoltage thresholds of all enabled IN1–IN8. |
| | | [1] | 1 = $\overline{\text{FAULT1}}$ depends on the primary overvoltage thresholds of all enabled IN1–IN8. |
| | | [2] | 1 = $\overline{\text{FAULT1}}$ depends on the secondary overvoltage thresholds of all enabled IN1–IN8. |
| | | [3] | 1 = $\overline{\text{FAULT1}}$ depends on the secondary overtemperature threshold of the internal temperature sensor. |
| | | [4] | 1 = $\overline{\text{FAULT1}}$ depends on the secondary overtemperature threshold of remote temperature sensor 1. |
| | | [5] | 1 = $\overline{\text{FAULT1}}$ depends on the secondary overtemperature threshold of remote temperature sensor 2. |
| | | [6] | 1 = $\overline{\text{FAULT1}}$ depends on the secondary overcurrent threshold. |
| | | [7] | Reserved |
| 1Eh | 9Eh | [0] | 1 = $\overline{\text{FAULT2}}$ depends on the secondary undervoltage thresholds of all enabled IN1–IN8. |
| | | [1] | 1 = $\overline{\text{FAULT2}}$ depends on the primary overvoltage thresholds of all enabled IN1–IN8. |
| | | [2] | 1 = $\overline{\text{FAULT2}}$ depends on the secondary overvoltage thresholds of all enabled IN1–IN8. |
| | | [3] | 1 = $\overline{\text{FAULT2}}$ depends on the secondary overtemperature threshold of the internal temperature sensor. |
| | | [4] | 1 = $\overline{\text{FAULT2}}$ depends on the secondary overtemperature threshold of remote temperature sensor 1. |
| | | [5] | 1 = $\overline{\text{FAULT2}}$ depends on the secondary overtemperature threshold of remote temperature sensor 2. |
| | | [6] | 1 = $\overline{\text{FAULT2}}$ depends on the secondary overcurrent threshold. |
| | | [7] | Reserved |
| 1Fh | 9Fh | [0] | 1 = $\overline{\text{OVERT}}$ depends on the primary overtemperature threshold of the internal temperature sensor. |
| | | [1] | 1 = $\overline{\text{OVERT}}$ depends on the primary overtemperature threshold of the remote temperature sensor 1. |
| | | [2] | 1 = $\overline{\text{OVERT}}$ depends on the primary overtemperature threshold of the remote temperature sensor 2. |

EEPROM-Based System Monitors with Nonvolatile Fault Memory

Table 8. Output Dependencies (continued)

| REGISTER ADDRESS | EEPROM MEMORY ADDRESS | BIT RANGE | DESCRIPTION |
|------------------|-----------------------|-----------|---|
| 1Fh | 9Fh | [3] | 1 = $\overline{\text{OVERT}}$ depends on the diode short flag of remote temperature sensor 1. $\overline{\text{OVERT}}$ latches when the diode is shorted. Clear the latch by writing to r50h. |
| | | [4] | 1 = $\overline{\text{OVERT}}$ depends on the diode open flag of remote temperature sensor 1. $\overline{\text{OVERT}}$ latches when the diode is open. Clear the latch by writing to r50h. |
| | | [5] | 1 = $\overline{\text{OVERT}}$ depends on the diode short flag of remote temperature sensor 2. $\overline{\text{OVERT}}$ latches when the diode is shorted. Clear the latch by writing to r50h. |
| | | [6] | 1 = $\overline{\text{OVERT}}$ depends on the diode open flag of remote temperature sensor 2. $\overline{\text{OVERT}}$ latches when the diode is open. Clear the latch by writing to r50h. |
| | | [7] | Reserved |
| 20h | A0h | [2:0] | <p>RESET Configuration: 000 = $\overline{\text{RESET}}$ has no dependencies; asserts during boot and boot-up timeout and then deasserts indefinitely. 001 = $\overline{\text{RESET}}$ depends on the primary undervoltage thresholds at inputs that are selected by r21h[7:0]. 010 = $\overline{\text{RESET}}$ depends on the primary overvoltage thresholds at inputs that are selected by r21h[7:0]. 011 = $\overline{\text{RESET}}$ depends on both the primary undervoltage and overvoltage thresholds at those inputs that are selected by r21h[7:0]. 100 = $\overline{\text{RESET}}$ depends on the primary undervoltage thresholds at inputs that are selected by r21h[7:0] and the internal temperature sensor primary overtemperature threshold. 101 = $\overline{\text{RESET}}$ depends on both the primary undervoltage and overvoltage thresholds at those inputs that are selected by r21h[7:0] and the internal temperature sensor primary overtemperature threshold. 110 = $\overline{\text{RESET}}$ depends on the primary undervoltage thresholds at inputs that are selected by r21h[7:0] and each internal/remote temperature sensor primary overtemperature threshold. 111 = $\overline{\text{RESET}}$ depends on both the primary undervoltage and overvoltage thresholds at those inputs that are selected by r21h[7:0] and each internal/remote temperature sensor primary overtemperature threshold.</p> |
| | | [5:3] | <p>RESET Timeout: 000 = 25μs 001 = 2.5ms 010 = 10ms 011 = 40ms 100 = 160ms 101 = 640ms 110 = 1280ms 111 = 2560ms</p> |
| | | [7:6] | Reserved |

EEPROM-Based System Monitors with Nonvolatile Fault Memory

MAX16031/MAX16032

Table 8. Output Dependencies (continued)

| REGISTER ADDRESS | EEPROM MEMORY ADDRESS | BIT RANGE | DESCRIPTION |
|------------------|-----------------------|-----------|--|
| 21h | A1h | [0] | 1 = $\overline{\text{RESET}}$ depends on IN1 with thresholds defined by r20h[2:0]. |
| | | [1] | 1 = $\overline{\text{RESET}}$ depends on IN2 with thresholds defined by r20h[2:0]. |
| | | [2] | 1 = $\overline{\text{RESET}}$ depends on IN3 with thresholds defined by r20h[2:0]. |
| | | [3] | 1 = $\overline{\text{RESET}}$ depends on IN4 with thresholds defined by r20h[2:0]. |
| | | [4] | 1 = $\overline{\text{RESET}}$ depends on IN5 with thresholds defined by r20h[2:0]. |
| | | [5] | 1 = $\overline{\text{RESET}}$ depends on IN6 with thresholds defined by r20h[2:0]. |
| | | [6] | 1 = $\overline{\text{RESET}}$ depends on IN7 with thresholds defined by r20h[2:0]. |
| | | [7] | 1 = $\overline{\text{RESET}}$ depends on IN8 with thresholds defined by r20h[2:0]. |
| 22h | A2h | [2:0] | <p>GPIO1 Output Dependencies: 000 = GPIO1 is a digital input that is read from r22h[7]. 001 = GPIO1 is a digital manual reset input that asserts $\overline{\text{RESET}}$ when asserted. The state of GPIO1 is read from r22h[7]. 010 = GPIO1 is a digital output that is written to through r22h[6]. 011 = GPIO1 is a digital fault output that depends on conditions selected by r23h[6:0]. 100 = GPIO1 is a digital output that depends on primary thresholds at the input selected by r22h[5:3]. 101 = GPIO1 is a digital output that depends on primary thresholds at the input selected by r22h[5:3] and on conditions selected by r23h[6:0]. 110 = Reserved 111 = Reserved</p> |
| | | [5:3] | <p>GPIO1 Single-Input Primary Threshold Voltage Monitor (r22h[2:0] = 100 or 101 only). GPIO1 asserts low when any primary threshold of this input is exceeded: 000 = IN1 001 = IN2 010 = IN3 011 = IN4 100 = IN5 101 = IN6 110 = IN7 111 = IN8</p> |
| | | [6] | <p>GPIO1 Output (write to this bit): 1 = GPIO1 is set high if GPIO1 is configured as an output. 0 = GPIO1 is set low if GPIO1 is configured as an output.</p> |
| | | [7] | <p>GPIO1 Input State (read from this bit): 1 = Indicates that GPIO1 is high regardless if GPIO1 is set as an output or input. 0 = Indicates that GPIO1 is low regardless if GPIO1 is set as an output or input.</p> |

EEPROM-Based System Monitors with Nonvolatile Fault Memory

Table 8. Output Dependencies (continued)

| REGISTER ADDRESS | EEPROM MEMORY ADDRESS | BIT RANGE | DESCRIPTION |
|------------------|-----------------------|-----------|--|
| 23h | A3h | [0] | 1 = GPIO1 depends on the secondary undervoltage thresholds of all enabled IN1–IN8. |
| | | [1] | 1 = GPIO1 depends on the primary overvoltage thresholds of all enabled IN1–IN8. |
| | | [2] | 1 = GPIO1 depends on the secondary overvoltage thresholds of all enabled IN1–IN8. |
| | | [3] | 1 = GPIO1 depends on the secondary overtemperature threshold of the internal temperature sensor. |
| | | [4] | 1 = GPIO1 depends on the secondary overtemperature threshold of remote temperature sensor 1. |
| | | [5] | 1 = GPIO1 depends on the secondary overtemperature threshold of remote temperature sensor 2. |
| | | [6] | 1 = GPIO1 depends on the secondary overcurrent threshold. |
| | | [7] | Reserved |
| 24h | A4h | [2:0] | <p>GPIO2 Output Dependencies:</p> <p>000 = GPIO2 is a digital input that is read from r24h[7].</p> <p>001 = GPIO2 is a digital manual reset input that asserts $\overline{\text{RESET}}$ when asserted. The state of GPIO2 is read from r24h[7].</p> <p>010 = GPIO2 is a digital output that is written to through r24h[6].</p> <p>011 = GPIO2 is a digital fault output that depends on conditions selected by r25h[6:0].</p> <p>100 = GPIO2 is a digital output that depends on primary thresholds at the input selected by r24h[5:3].</p> <p>101 = GPIO2 is a digital output that depends on primary thresholds at the input selected by r24h[5:3] and on conditions selected by r25h[6:0].</p> <p>110 = Reserved</p> <p>111 = Reserved</p> |
| | | [5:3] | <p>GPIO2 Single-Input Primary Threshold Voltage Monitor (r24h[2:0] = 100 or 101 only).</p> <p>GPIO2 asserts low when the primary threshold of this input is exceeded:</p> <p>000 = IN1</p> <p>001 = IN2</p> <p>010 = IN3</p> <p>011 = IN4</p> <p>100 = IN5</p> <p>101 = IN6</p> <p>110 = IN7</p> <p>111 = IN8</p> |
| | | [6] | <p>GPIO2 Output (write to this bit):</p> <p>1 = GPIO2 is set high if GPIO2 is configured as an output.</p> <p>0 = GPIO2 is set low if GPIO2 is configured as an output.</p> |
| | | [7] | <p>GPIO2 Input (read from this bit):</p> <p>1 = Indicates that GPIO2 is high regardless if GPIO2 is set as an output or input.</p> <p>0 = Indicates that GPIO2 is low regardless if GPIO2 is set as an output or input.</p> |

EEPROM-Based System Monitors with Nonvolatile Fault Memory

Table 8. Output Dependencies (continued)

| REGISTER ADDRESS | EEPROM MEMORY ADDRESS | BIT RANGE | DESCRIPTION |
|------------------|-----------------------|-----------|--|
| 25h | A5h | [0] | 1 = GPIO2 depends on the secondary undervoltage thresholds of all enabled IN1–IN8. |
| | | [1] | 1 = GPIO2 depends on the primary overvoltage thresholds of all enabled IN1–IN8. |
| | | [2] | 1 = GPIO2 depends on the secondary overvoltage thresholds of all enabled IN1–IN8. |
| | | [3] | 1 = GPIO2 depends on the secondary overtemperature threshold of the internal temperature sensor. |
| | | [4] | 1 = GPIO2 depends on the secondary overtemperature threshold of remote temperature sensor 1. |
| | | [5] | 1 = GPIO2 depends on the secondary overtemperature threshold of remote temperature sensor 2. |
| | | [6] | 1 = GPIO2 depends on the secondary overcurrent threshold. |
| | | [7] | Reserved |

Faults

The MAX16031/MAX16032 offer many configurable options for detecting and managing system faults. Fault thresholds are set in r26h–r4Eh, as shown in Table 9. Any threshold that is configured to cause a fault can be masked at any time from causing a fault by setting bits

in r54h–r57h, as shown in Table 10. Fault flags indicate the fault status of a particular input. The fault flag of any monitored input in the device can be read at any time from r50h–r53h, as shown in Table 11. Clear a fault flag by writing a '1' to the appropriate bit in the flag register.

Table 9. Fault Thresholds

| REGISTER ADDRESS | EEPROM MEMORY ADDRESS | BIT RANGE | DESCRIPTION |
|------------------|-----------------------|-----------|--------------------------------------|
| 26h | A6h | [7:0] | IN1 Primary Undervoltage Threshold |
| 27h | A7h | [7:0] | IN1 Primary Overvoltage Threshold |
| 28h | A8h | [7:0] | IN1 Secondary Undervoltage Threshold |
| 29h | A9h | [7:0] | IN1 Secondary Overvoltage Threshold |
| 2Ah | AAh | [7:0] | IN2 Primary Undervoltage Threshold |
| 2Bh | ABh | [7:0] | IN2 Primary Overvoltage Threshold |
| 2Ch | ACH | [7:0] | IN2 Secondary Undervoltage Threshold |
| 2Dh | ADh | [7:0] | IN2 Secondary Overvoltage Threshold |
| 2Eh | A Eh | [7:0] | IN3 Primary Undervoltage Threshold |
| 2Fh | AFh | [7:0] | IN3 Primary Overvoltage Threshold |
| 30h | B0h | [7:0] | IN3 Secondary Undervoltage Threshold |
| 31h | B1h | [7:0] | IN3 Secondary Overvoltage Threshold |
| 32h | B2h | [7:0] | IN4 Primary Undervoltage Threshold |
| 33h | B3h | [7:0] | IN4 Primary Overvoltage Threshold |

EEPROM-Based System Monitors with Nonvolatile Fault Memory

Table 9. Fault Thresholds (continued)

| REGISTER ADDRESS | EEPROM MEMORY ADDRESS | BIT RANGE | DESCRIPTION |
|------------------|-----------------------|-----------|--|
| 34h | B4h | [7:0] | IN4 Secondary Undervoltage Threshold |
| 35h | B5h | [7:0] | IN4 Secondary Overvoltage Threshold |
| 36h | B6h | [7:0] | IN5 Primary Undervoltage Threshold |
| 37h | B7h | [7:0] | IN5 Primary Overvoltage Threshold |
| 38h | B8h | [7:0] | IN5 Secondary Undervoltage Threshold |
| 39h | B9h | [7:0] | IN5 Secondary Overvoltage Threshold |
| 3Ah | BAh | [7:0] | IN6 Primary Undervoltage Threshold |
| 3Bh | BBh | [7:0] | IN6 Primary Overvoltage Threshold |
| 3Ch | BCh | [7:0] | IN6 Secondary Undervoltage Threshold |
| 3Dh | BDh | [7:0] | IN6 Secondary Overvoltage Threshold |
| 3Eh | BEh | [7:0] | IN7 Primary Undervoltage Threshold |
| 3Fh | BFh | [7:0] | IN7 Primary Overvoltage Threshold |
| 40h | C0h | [7:0] | IN7 Secondary Undervoltage Threshold |
| 41h | C1h | [7:0] | IN7 Secondary Overvoltage Threshold |
| 42h | C2h | [7:0] | IN8 Primary Undervoltage Threshold |
| 43h | C3h | [7:0] | IN8 Primary Overvoltage Threshold |
| 44h | C4h | [7:0] | IN8 Secondary Undervoltage Threshold |
| 45h | C5h | [7:0] | IN8 Secondary Overvoltage Threshold |
| 46h | C6h | [7:0] | Internal Temperature Sensor Primary Overtemperature Threshold MSB (2 LSBs are in r4Dh[1:0]). |
| 47h | C7h | [7:0] | Internal Temperature Sensor Secondary Overtemperature Threshold MSB (2 LSBs are in r4Dh[3:2]). |
| 48h | C8h | [7:0] | Remote Temperature Sensor 1 Primary Overtemperature Threshold MSB (2 LSBs are in r4Eh[1:0]). |
| 49h | C9h | [7:0] | Remote Temperature Sensor 1 Secondary Overtemperature Threshold MSB (2 LSBs are in r4Eh[3:2]). |
| 4Ah | CAh | [7:0] | Remote Temperature Sensor 2 Primary Overtemperature Threshold MSB (2 LSBs are in r4Eh[5:4]). |
| 4Bh | CBh | [7:0] | Remote Temperature Sensor 2 Secondary Overtemperature Threshold MSB (2 LSBs are in r4Eh[7:6]). |
| 4Ch | CCh | [7:0] | Current-Sense Secondary Threshold |
| 4Dh | CDh | [1:0] | Internal Temperature Sensor Primary Overtemperature Threshold LSB |
| | | [3:2] | Internal Temperature Sensor Secondary Overtemperature Threshold LSB |
| | | [6:4] | Remote Temperature Sensor 2, Offset Trim |
| | | [7] | Not used |
| 4Eh | CEh | [1:0] | Remote Temperature Sensor 1 Primary Overtemperature Threshold LSB |
| | | [3:2] | Remote Temperature Sensor 1 Secondary Overtemperature Threshold LSB |
| | | [5:3] | Remote Temperature Sensor 2 Primary Overtemperature Threshold LSB |
| | | [7:6] | Remote Temperature Sensor 2 Secondary Overtemperature Threshold LSB |

EEPROM-Based System Monitors with Nonvolatile Fault Memory

MAX16031/MAX16032

Table 10. Fault Masks

| REGISTER ADDRESS | EEPROM MEMORY ADDRESS | BIT RANGE | DESCRIPTION |
|------------------|-----------------------|-----------|---|
| 54h | D4h | [0] | 1 = Short-circuit detection at remote temperature sensor 1 is masked. |
| | | [1] | 1 = Open-circuit detection at remote temperature sensor 1 is masked. |
| | | [2] | 1 = Short-circuit detection at remote temperature sensor 2 is masked. |
| | | [3] | 1 = Open-circuit detection at remote temperature sensor 2 is masked. |
| | | [7:4] | Not used. |
| 55h | D5h | [0] | 1 = IN1 primary overvoltage and undervoltage faults are masked. |
| | | [1] | 1 = IN2 primary overvoltage and undervoltage faults are masked. |
| | | [2] | 1 = IN3 primary overvoltage and undervoltage faults are masked. |
| | | [3] | 1 = IN4 primary overvoltage and undervoltage faults are masked. |
| | | [4] | 1 = IN5 primary overvoltage and undervoltage faults are masked. |
| | | [5] | 1 = IN6 primary overvoltage and undervoltage faults are masked. |
| | | [6] | 1 = IN7 primary overvoltage and undervoltage faults are masked. |
| | | [7] | 1 = IN8 primary overvoltage and undervoltage faults are masked. |
| 56h | D6h | [0] | 1 = IN1 secondary overvoltage and undervoltage faults are masked. |
| | | [1] | 1 = IN2 secondary overvoltage and undervoltage faults are masked. |
| | | [2] | 1 = IN3 secondary overvoltage and undervoltage faults are masked. |
| | | [3] | 1 = IN4 secondary overvoltage and undervoltage faults are masked. |
| | | [4] | 1 = IN5 secondary overvoltage and undervoltage faults are masked. |
| | | [5] | 1 = IN6 secondary overvoltage and undervoltage faults are masked. |
| | | [6] | 1 = IN7 secondary overvoltage and undervoltage faults are masked. |
| | | [7] | 1 = IN8 secondary overvoltage and undervoltage faults are masked. |
| 57h | D7h | [0] | 1 = Internal temperature sensor primary overtemperature fault masked. |
| | | [1] | 1 = Remote temperature sensor 1 primary overtemperature fault masked. |
| | | [2] | 1 = Remote temperature sensor 2 primary overtemperature fault masked. |
| | | [3] | 1 = Internal temperature sensor secondary overtemperature fault masked. |
| | | [4] | 1 = Remote temperature sensor 1 secondary overtemperature fault masked. |
| | | [5] | 1 = Remote temperature sensor 2 secondary overtemperature fault masked. |
| | | [6] | 1 = Current-sense primary overcurrent fault masked. |
| | | [7] | 1 = Current-sense secondary overcurrent fault masked. |

EEPROM-Based System Monitors with Nonvolatile Fault Memory

Table 11. Fault Flags

| REGISTER ADDRESS | EEPROM MEMORY ADDRESS | BIT RANGE | DESCRIPTION |
|------------------|-----------------------|-----------|---|
| 50h | D0h | [0] | 1 = Short circuit detected at remote temperature sensor 1. |
| | | [1] | 1 = Open circuit detected at remote temperature sensor 1. |
| | | [2] | 1 = Short circuit detected at remote temperature sensor 2. |
| | | [3] | 1 = Open circuit detected at remote temperature sensor 2. |
| | | [7:4] | Not used. |
| 51h | D1h | [0] | 1 = IN1 conversion result exceeds primary overvoltage or undervoltage thresholds. |
| | | [1] | 1 = IN2 conversion result exceeds primary overvoltage or undervoltage thresholds. |
| | | [2] | 1 = IN3 conversion result exceeds primary overvoltage or undervoltage thresholds. |
| | | [3] | 1 = IN4 conversion result exceeds primary overvoltage or undervoltage thresholds. |
| | | [4] | 1 = IN5 conversion result exceeds primary overvoltage or undervoltage thresholds. |
| | | [5] | 1 = IN6 conversion result exceeds primary overvoltage or undervoltage thresholds. |
| | | [6] | 1 = IN7 conversion result exceeds primary overvoltage or undervoltage thresholds. |
| | | [7] | 1 = IN8 conversion result exceeds primary overvoltage or undervoltage thresholds. |
| 52h | D2h | [0] | 1 = IN1 conversion result exceeds secondary overvoltage or undervoltage thresholds. |
| | | [1] | 1 = IN2 conversion result exceeds secondary overvoltage or undervoltage thresholds. |
| | | [2] | 1 = IN3 conversion result exceeds secondary overvoltage or undervoltage thresholds. |
| | | [3] | 1 = IN4 conversion result exceeds secondary overvoltage or undervoltage thresholds. |
| | | [4] | 1 = IN5 conversion result exceeds secondary overvoltage or undervoltage thresholds. |
| | | [5] | 1 = IN6 conversion result exceeds secondary overvoltage or undervoltage thresholds. |
| | | [6] | 1 = IN7 conversion result exceeds secondary overvoltage or undervoltage thresholds. |
| | | [7] | 1 = IN8 conversion result exceeds secondary overvoltage or undervoltage thresholds. |
| 53h | D3h | [0] | 1 = Internal temperature sensor conversion exceeds its primary overtemperature threshold. |
| | | [1] | 1 = Remote temperature sensor 1 conversion exceeds its primary overtemperature threshold. |
| | | [2] | 1 = Remote temperature sensor 2 conversion exceeds its primary overtemperature threshold. |
| | | [3] | 1 = Internal temperature sensor conversion exceeds its secondary overtemperature threshold. |
| | | [4] | 1 = Remote temperature sensor 1 conversion exceeds its secondary overtemperature threshold. |
| | | [5] | 1 = Remote temperature sensor 2 conversion exceeds its secondary overtemperature threshold. |
| | | [6] | 1 = Current-sense conversion exceeds its primary overcurrent threshold. |
| | | [7] | 1 = Current-sense conversion exceeds its secondary overcurrent threshold. |

EEPROM-Based System Monitors with Nonvolatile Fault Memory

MAX16031/MAX16032

Table 12. Fault Log Dependency

| REGISTER ADDRESS | EEPROM MEMORY ADDRESS | BIT RANGE | DESCRIPTION |
|------------------|-----------------------|-----------|--|
| 58h | D8h | [0] | 1 = Fault log triggered when IN1 is below its primary undervoltage threshold. |
| | | [1] | 1 = Fault log triggered when IN2 is below its primary undervoltage threshold. |
| | | [2] | 1 = Fault log triggered when IN3 is below its primary undervoltage threshold. |
| | | [3] | 1 = Fault log triggered when IN4 is below its primary undervoltage threshold. |
| | | [4] | 1 = Fault log triggered when IN5 is below its primary undervoltage threshold. |
| | | [5] | 1 = Fault log triggered when IN6 is below its primary undervoltage threshold. |
| | | [6] | 1 = Fault log triggered when IN7 is below its primary undervoltage threshold. |
| | | [7] | 1 = Fault log triggered when IN8 is below its primary undervoltage threshold. |
| 59h | D9h | [0] | 1 = Fault log triggered when IN1 is above its primary overvoltage threshold. |
| | | [1] | 1 = Fault log triggered when IN2 is above its primary overvoltage threshold. |
| | | [2] | 1 = Fault log triggered when IN3 is above its primary overvoltage threshold. |
| | | [3] | 1 = Fault log triggered when IN4 is above its primary overvoltage threshold. |
| | | [4] | 1 = Fault log triggered when IN5 is above its primary overvoltage threshold. |
| | | [5] | 1 = Fault log triggered when IN6 is above its primary overvoltage threshold. |
| | | [6] | 1 = Fault log triggered when IN7 is above its primary overvoltage threshold. |
| | | [7] | 1 = Fault log triggered when IN8 is above its primary overvoltage threshold. |
| 5Ah | DAh | [0] | 1 = Fault log triggered when current sense is above its primary overcurrent threshold. |
| | | [1] | 1 = Fault log triggered when internal temperature sensor is above its overtemperature threshold. |
| | | [2] | 1 = Fault log triggered when remote temperature sensor 1 is above its overtemperature threshold. |
| | | [3] | 1 = Fault log triggered when remote temperature sensor 2 is above its overtemperature threshold. |
| | | [7:4] | Not used. |

Fault Logging

If a specific input threshold is critical to the operation of the system, an automatic fault log is configured to trigger a transfer of fault information to EEPROM. The fault log dependencies are configured through r58h–r5Ah, as shown in Table 12. Logged fault information is read from EEPROM locations r80h–r8Eh, as shown in Table 13. Once a fault log event occurs, the fault log feature is locked and must be reset to enable a new fault log to be stored. Write a '1' to r5Fh[1] to reset the fault log. Fault information always contains the fault flag registers and is configured to also include the ADC result registers through r5Ch[7] (see the *Miscellaneous Settings* section). All stored ADC results are the 8 MSBs of the result.

Miscellaneous Settings

Table 14 shows several miscellaneous programmable items. Register r5Bh contains boot-up timeout and

remote temperature sensor filter cutoff settings. Register r5Ch[1:0] sets the secondary overcurrent threshold timeout, which is the amount of delay after an overcurrent condition before the overcurrent condition becomes a fault. All voltage thresholds include two selectable hysteresis options programmed by r5Ch[5]. When r5Ch[6] = 1, the conditions programmed to cause a fault log event must happen for two consecutive ADC cycles rather than just one to provide an improvement in noise immunity. Register r5Ch[7] controls whether the ADC result registers are stored in EEPROM after a fault log. Register r5Eh provides storage space for a user-defined configuration or firmware version number. Register r5Fh[0] locks and unlocks the EEPROM and register set. Register r5Fh[1] indicates whether a fault log event occurred and the corresponding fault information is locked in EEPROM. Further fault log conditions will not write new fault information to the fault EEPROM until a '1' is written to r5Fh[1].

EEPROM-Based System Monitors with Nonvolatile Fault Memory

Table 13. Fault Log EEPROM

| REGISTER ADDRESS | EEPROM MEMORY ADDRESS | BIT RANGE | DESCRIPTION |
|------------------|-----------------------|-----------|---|
| — | 80h | [7:0] | Copy of r51h[7:0] at the time the fault log was triggered. |
| — | 81h | [7:0] | Copy of r52h[7:0] at the time the fault log was triggered. |
| — | 82h | [7:0] | Copy of r53h[7:0] at the time the fault log was triggered. |
| — | 83h | [7:0] | IN1 conversion result at the time the fault log was triggered. |
| — | 84h | [7:0] | IN2 conversion result at the time the fault log was triggered. 8 MSBs only. |
| — | 85h | [7:0] | IN3 conversion result at the time the fault log was triggered. 8 MSBs only. |
| — | 86h | [7:0] | IN4 conversion result at the time the fault log was triggered. 8 MSBs only. |
| — | 87h | [7:0] | IN5 conversion result at the time the fault log was triggered. 8 MSBs only. |
| — | 88h | [7:0] | IN6 conversion result at the time the fault log was triggered. 8 MSBs only. |
| — | 89h | [7:0] | IN7 conversion result at the time the fault log was triggered. 8 MSBs only. |
| — | 8Ah | [7:0] | IN8 conversion result at the time the fault log was triggered. 8 MSBs only. |
| — | 8Bh | [7:0] | Internal temperature sensor conversion result at the time the fault log was triggered. 8 MSBs from 10-bit ADC conversion. |
| — | 8Ch | [7:0] | Remote temperature sensor 1 conversion result at the time the fault log was triggered. 8 MSBs from 10-bit ADC conversion. |
| — | 8Dh | [7:0] | Remote temperature sensor 2 conversion result at the time the fault log was triggered. 8 MSBs from 10-bit ADC conversion. |
| — | 8Eh | [7:0] | Current-sense conversion result at the time the fault log was triggered. |

I²C/SMBus-Compatible Serial Interface

The MAX16031/MAX16032 feature an I²C/SMBus-compatible 2-wire (SDA and SCL) serial interface for communication with a master device. All possible communication formats are shown in Figure 5. The slave address and SMBALERT# are described further in the following subsections. Figure 1 shows a detailed 2-wire interface timing diagram. For descriptions of the I²C and SMBus protocol and terminology, refer to the I²C-Bus Specification Version 2.1 and the System Management Bus (SMBus) Specification Version 2.0. The MAX16031/MAX16032 allow 2-wire communication up to 400kHz. SDA and SCL require external pullup resistors.

Slave Address

The slave address inputs, A0 and A1, are each capable of detecting three different states, allowing nine identical devices to share the same serial bus. Connect A0 and A1 to GND, DBP, or leave as not connected (N.C.). See Table 15 for a listing of all possible 7-bit address input connections and their corresponding serial-bus addresses.

SMBALERT#

SMBALERT# is an optional interrupt signal defined in Appendix A of the SMBus Specification. The MAX16031/MAX16032 provide output $\overline{\text{ALERT}}$ as this interrupt signal. If enabled, $\overline{\text{ALERT}}$ asserts if any one of the following outputs asserts: $\overline{\text{FAULT1}}$, $\overline{\text{FAULT2}}$, $\overline{\text{RESET}}$, $\overline{\text{OVERT}}$, or $\overline{\text{OVERC}}$. Additionally, if a GPIO_ is configured for a fault output, a fault at this output also causes $\overline{\text{ALERT}}$ to assert. $\overline{\text{ALERT}}$ deasserts when all fault conditions are removed (i.e., when all fault outputs are high).

Typically $\overline{\text{ALERT}}$ is connected to all other SMBALERT# open-drain signals in the system, creating a wired-OR function with all SMBALERT# outputs. When the master is interrupted by its SMBALERT# input, it stops or finishes the current bus transfer and places an alert response address (ARA) on the bus. The slave that pulled the SMBALERT# signal low acknowledges the ARA and places its own address on the bus, identifying itself to the master as the slave that caused the interrupt. The 7-bit ARA is '0001100' and the R/W bit is a don't care.

EEPROM-Based System Monitors with Nonvolatile Fault Memory

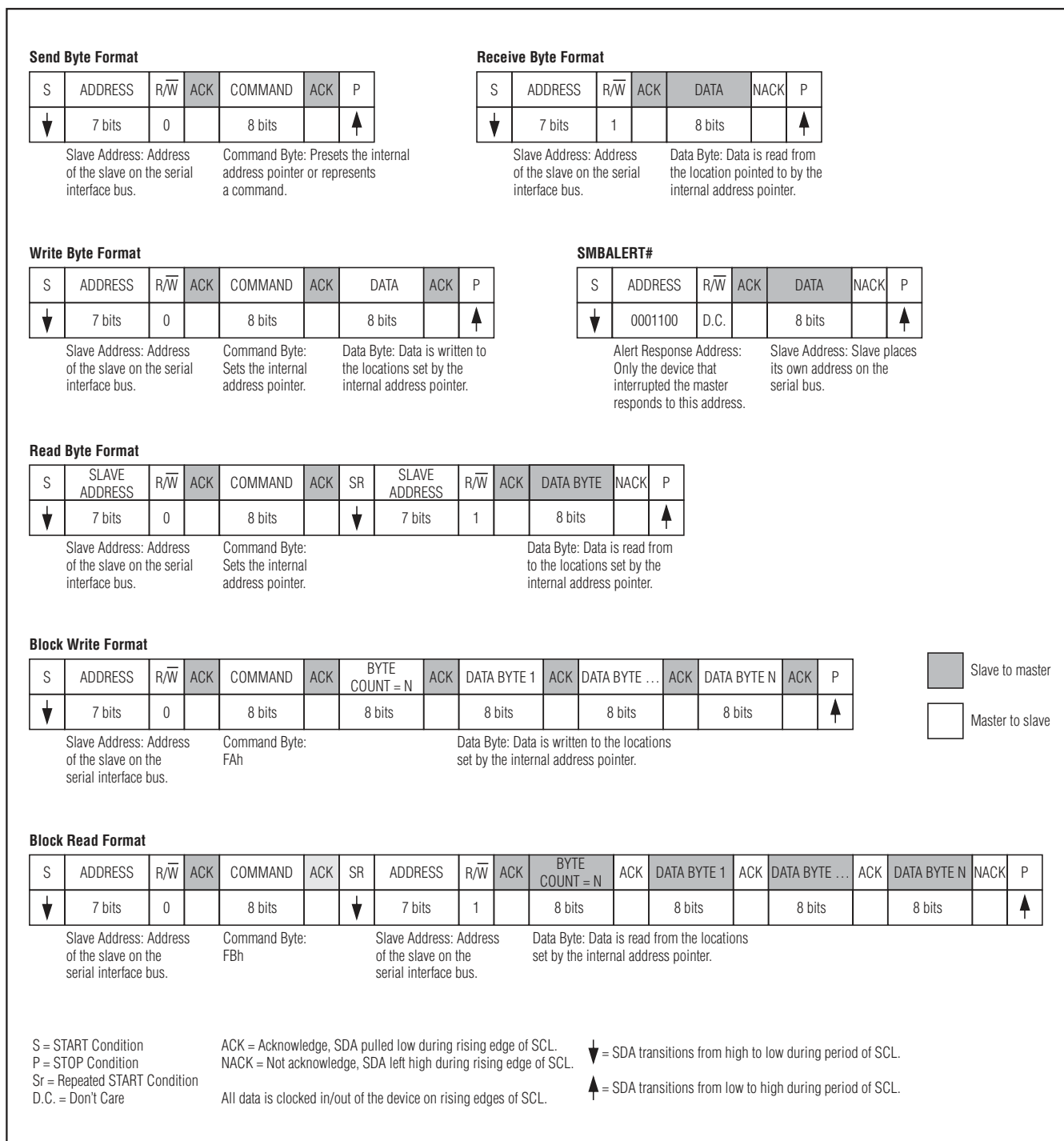

Figure 5. Communication Formats

EEPROM-Based System Monitors with Nonvolatile Fault Memory

Table 14. Miscellaneous Settings

| REGISTER ADDRESS | EEPROM MEMORY ADDRESS | BIT RANGE | DESCRIPTION |
|------------------|-----------------------|-----------|---|
| 5Bh | DBh | [3:0] | Postboot Timeout (all faults and outputs masked): 0h = No timeout 1h = 0.974ms 2h = 2.030ms 3h = 3.978ms 4h = 8.038ms 5h = 15.99ms 6h = 31.99ms 7h = 63.99ms 8h = 128ms 9h = 256.0ms Ah = 512ms Bh = 1024ms Ch = 2048ms Dh = 4096ms Eh = 8192ms Fh = 16384ms |
| | | [6:4] | Temperature Sensor Lowpass Filter Cutoff: 000 = No filter 001 = 2.53Hz 010 = 5.06Hz 011 = 10.1Hz 100 = 20.2Hz 101 = 40.5Hz 110 = 81Hz 111 = 162Hz |
| | | [7] | Not used. |
| 5Ch | DCh | [1:0] | Overcurrent Secondary Threshold Timeout: 00 = 50μs 01 = 3.98ms 10 = 16ms 11 = 64ms |
| | | [2] | Latch OVERC: 0 = No latch 1 = Latched after assertion |
| | | [4:3] | Not used. |
| | | [5] | Threshold Hysteresis (all thresholds): 0 = 0.78% 1 = 1.17% |
| 5Ch | DCh | [6] | Consecutive Faults on Primary Thresholds: 0 = Fault occurs after primary threshold is exceeded one time (normal operation). 1 = Fault occurs after primary threshold is exceeded twice. |
| | | [7] | Fault Log ADC Conversions Option: 0 = When a fault log is triggered, only fault flags are saved in EEPROM. 1 = When a fault log is triggered, fault flags and ADC conversion results (8 MSBs) are saved in EEPROM. |

EEPROM-Based System Monitors with Nonvolatile Fault Memory

Table 14. Miscellaneous Settings (continued)

| REGISTER ADDRESS | EEPROM MEMORY ADDRESS | BIT RANGE | DESCRIPTION |
|------------------|-----------------------|-----------|---|
| 5Eh | DEh | [7:0] | Firmware Version. 8 bits of memory for user-defined firmware version number. |
| 5Fh | DFh | [0] | Configuration Lock: Write a '1' to r5Fh[0] to toggle this register bit. 0 = Register and EEPROM configuration unlocked. 1 = Register and EEPROM configuration locked. |
| | | [1] | Fault Log EEPROM Lock Flag (set automatically after fault log is triggered): Write a '1' to r5Fh[1] to toggle this register bit. 0 = EEPROM is not locked. A triggered fault log stores fault information to EEPROM. 1 = A fault log has been triggered. Write a '1' to this bit to clear the flag and allow a new fault log to be triggered. |
| | | [7:2] | Not used. |

Table 15. Setting the I²C/SMBus Slave Address

| A1 | A0 | BUS ADDRESS |
|------|------|-------------|
| GND | GND | 0011000 |
| GND | N.C. | 0011001 |
| GND | DBP | 0011010 |
| N.C. | GND | 0101001 |
| N.C. | N.C. | 0101010 |
| N.C. | DBP | 0101011 |
| DBP | GND | 1001100 |
| DBP | N.C. | 1001111 |
| DBP | DBP | 1001110 |

Special Commands

The MAX16031/MAX16032 provide software reboot and fault log commands. A software reboot initiates the boot-up sequence, which normally occurs at POR. During boot-up, EEPROM configuration data is copied to registers. To initiate a software reboot, send 0xFC using the send byte format. A software-initiated fault log is functionally the same as a hardware-initiated fault log. During a fault log, ADC registers and fault information are logged in EEPROM. To trigger a software initiated fault log, send 0xFD using the send byte format.

JTAG Serial Interface

The MAX16031/MAX16032 contain an IEEE® 1149.1-compliant JTAG port in addition to the I²C/SMBus-compatible serial bus. Either interface may be used to access internal memory; however, only one interface is allowed to run at a time. All digital I/Os on the MAX16031/MAX16032 are IEEE 1149.1 boundary-scan compliant, and contain the typical JTAG boundary scan cells that allow the inputs/outputs to be polled or forced high/low using standard JTAG instructions. The MAX16031/MAX16032 contain extra JTAG instructions and registers not included in the JTAG specification that provide access to internal memory. The extra instructions are: LOAD ADDRESS, WRITE, READ, REBOOT, SAVE, and USERCODE. The extra registers are: memory address, memory write, memory read, and user-code data. See Figure 6 for a block diagram of the JTAG interface.

Test Access Port (TAP) Controller State Machine

The TAP controller is a finite state machine that responds to the logic level at TMS on the rising edge of TCK. See Figure 7 for a diagram of the finite state machine.

Test-Logic-Reset: At power-up, the TAP controller is in the test-logic-reset state. The instruction register contains the IDCODE instruction. All system logic of the device operates normally.

IEEE is a registered service mark of the Institute of Electrical and Electronics, Inc.

EEPROM-Based System Monitors with Nonvolatile Fault Memory

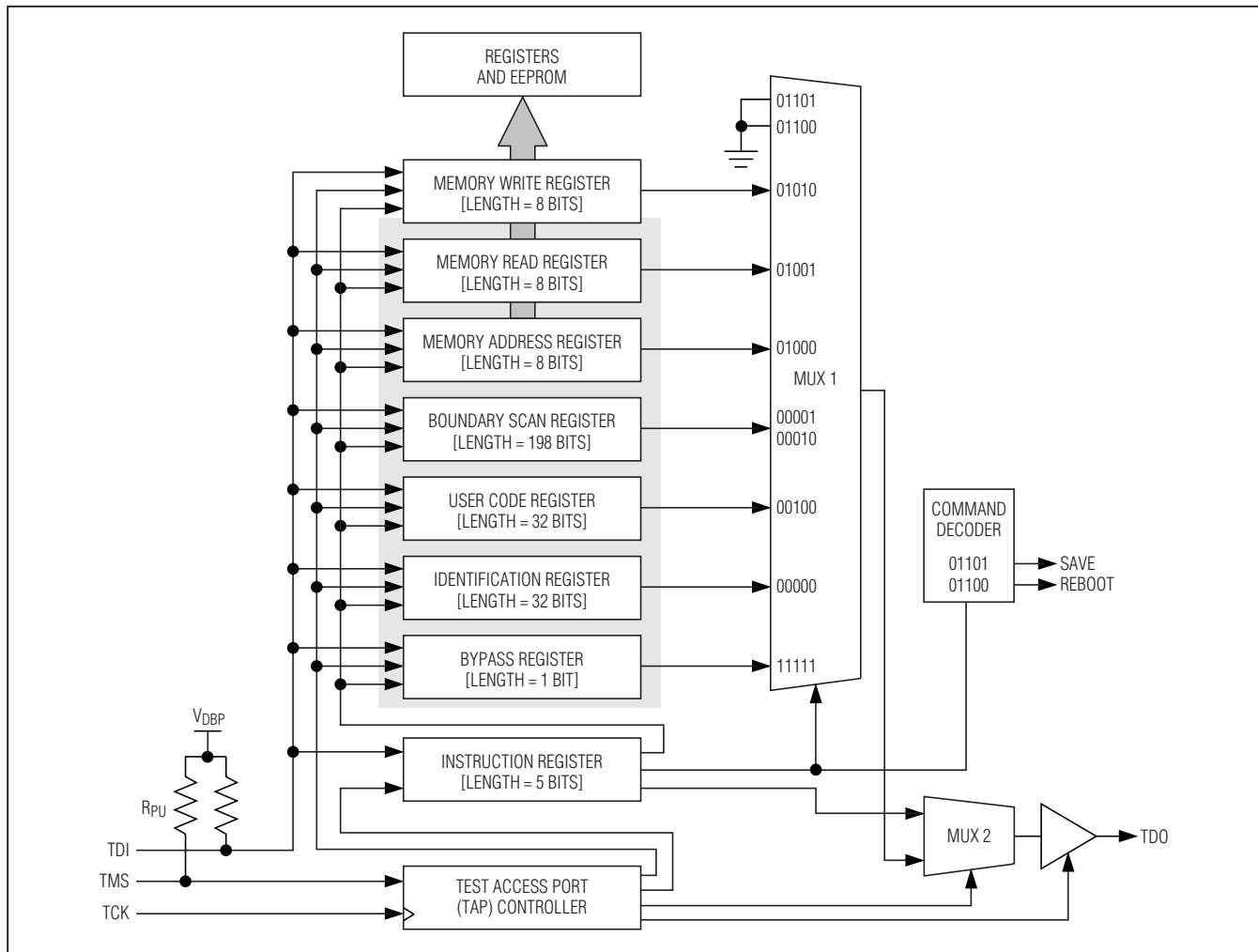

Figure 6. JTAG Block Diagram

Run-Test/Idle: The run-test/idle state is used between scan operations or during specific tests. The instruction register and test data registers remain idle.

Select-DR-Scan: All test data registers retain their previous state. With TMS low, a rising edge of TCK moves the controller into the capture-DR state and initiates a scan sequence. TMS high during a rising edge on TCK moves the controller to the select-IR-scan state.

Capture-DR: Data are parallel-loaded into the test data registers selected by the current instruction. If the instruction does not call for a parallel load or the selected test data register does not allow parallel loads, the test data register remains at its current value. On the rising edge of TCK, the controller goes to the shift-DR state if TMS is low or it goes to the exit1-DR state if TMS is high.

Shift-DR: The test data register selected by the current instruction is connected between TDI and TDO and shifts data one stage toward its serial output on each rising edge of TCK while TMS is low. On the rising edge of TCK, the controller goes to the exit1-DR state if TMS is high.

Exit1-DR: While in this state, a rising edge on TCK puts the controller in the update-DR state. A rising edge on TCK with TMS low puts the controller in the pause-DR state.

Pause-DR: Shifting of the test data registers is halted while in this state. All test data registers retain their previous state. The controller remains in this state while TMS is low. A rising edge on TCK with TMS high puts the controller in the exit2-DR state.

EEPROM-Based System Monitors with Nonvolatile Fault Memory

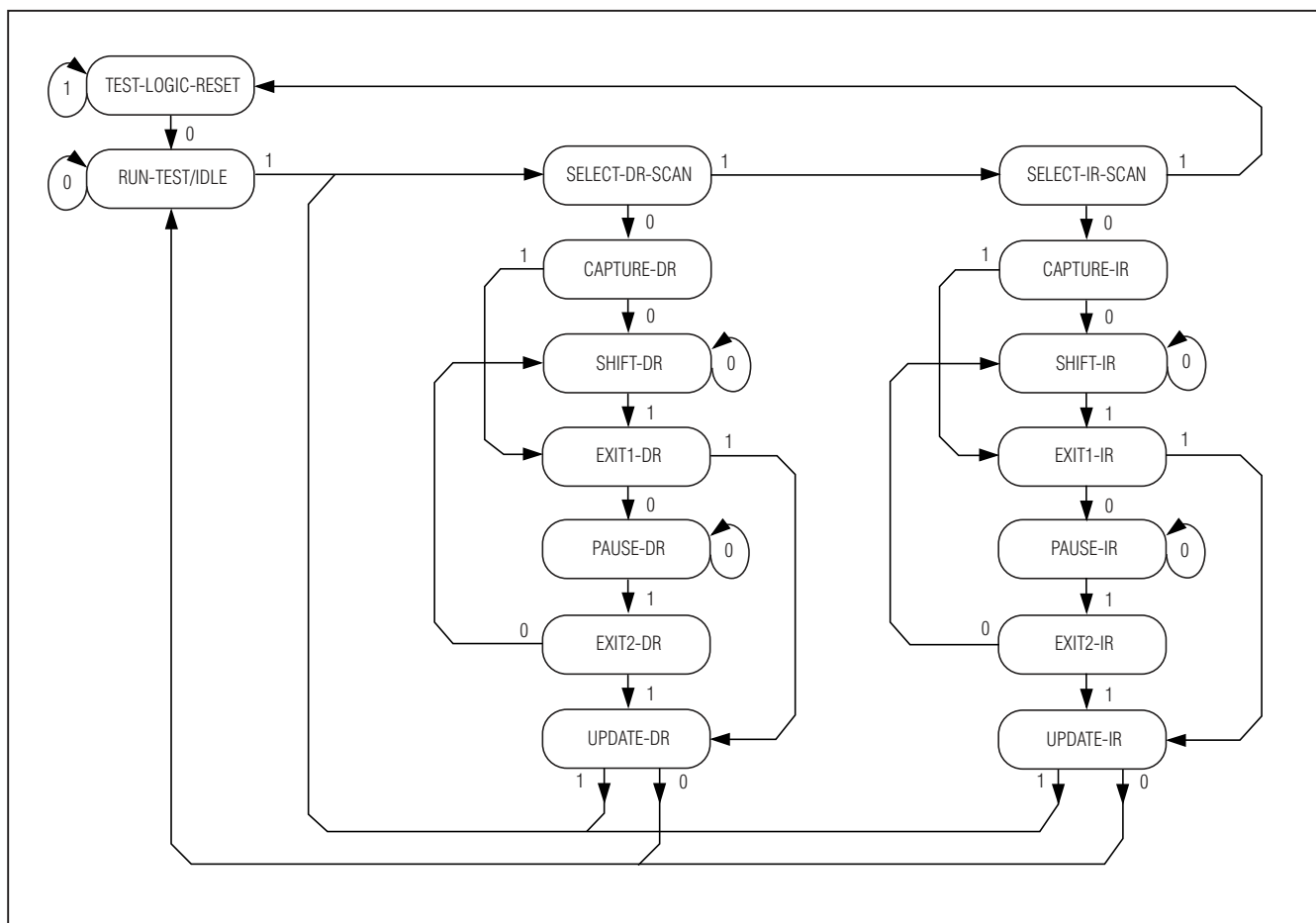

Figure 7. TAP Controller State Diagram

Exit2-DR: A rising edge on TCK with TMS high while in this state puts the controller in the update-DR state. A rising edge on TCK with TMS low enters the Shift-DR state.

Update-DR: A falling edge on TCK while in the update-DR state latches the data from the shift register path of the test data registers into a set of output latches. This prevents changes at the parallel output because of changes in the shift register. On the rising edge of TCK, the controller goes to the run-test/idle state if TMS is low or it goes to the select-DR-scan state if TMS is high.

Select-IR-Scan: All test data registers retain their previous state. The instruction register remains unchanged during this state. With TMS low, a rising edge on TCK moves the controller into the capture-IR state. TMS high during a rising edge on TCK puts the controller back into the test-logic-reset state.

Capture-IR: Use the capture-IR state to load the shift register in the instruction register with a fixed value. This value is loaded on the rising edge of TCK. If TMS is high on the rising edge of TCK, the controller enters the exit1-IR state. If TMS is low on the rising edge of TCK, the controller enters the shift-IR state.

Shift-IR: In this state, the shift register in the instruction register is connected between TDI and TDO and shifts data one stage for every rising edge of TCK toward the TDO serial output while TMS is low. The parallel outputs of the instruction register as well as all test data registers remain at their previous states. A rising edge on TCK with TMS high moves the controller to the exit1-IR state. A rising edge on TCK with TMS low keeps the controller in the shift-IR state while moving data one stage through the instruction shift register.

EEPROM-Based System Monitors with Nonvolatile Fault Memory

Exit1-IR: A rising edge on TCK with TMS low puts the controller in the pause-IR state. If TMS is high on the rising edge of TCK, the controller enters the update-IR state.

Pause-IR: Shifting of the instruction shift register is halted temporarily. With TMS high, a rising edge on TCK puts the controller in the exit2-IR state. The controller remains in the pause-IR state if TMS is low during a rising edge on TCK.

Exit2-IR: A rising edge on TCK with TMS high puts the controller in the update-IR state. The controller loops back to shift-IR if TMS is low during a rising edge of TCK in this state.

Update-IR: The instruction code that has been shifted into the instruction shift register is latched to the parallel outputs of the instruction register on the falling edge of TCK as the controller enters this state. Once latched, this instruction becomes the current instruction. A rising edge on TCK with TMS low puts the controller in the run-test/idle state. With TMS high, the controller enters the select-DR-scan state.

Instruction Register

The instruction register contains a shift register as well as a latched parallel output and is 5 bits in length. When the TAP controller enters the shift-IR state, the instruction shift register is connected between TDI and TDO. While in the shift-IR state, a rising edge on TCK with TMS low shifts the data one stage toward the serial output at TDO. A rising edge on TCK in the exit1-IR state or the exit2-IR state with TMS high moves the controller to the update-IR state. The falling edge of that same TCK latches the data in the instruction shift register to the instruction register parallel output. Instructions supported by the MAX16031/MAX16032 and their respective operational binary codes are shown in Table 16.

SAMPLE/PRELOAD: This is a mandatory instruction for the IEEE 1149.1 specification that supports two functions. The digital I/Os of the device are sampled at the boundary scan test data register without interfering with the normal operation of the device by using the capture-DR state. SAMPLE/PRELOAD also allows the device to shift data into the boundary scan test data register through TDI using the shift-DR state.

BYPASS: When the BYPASS instruction is latched into the instruction register, TDI connects to TDO through the 1-bit bypass test data register. This allows data to pass from DTDI to TDO without affecting the device's normal operation.

EXTEST: This instruction allows testing of all interconnections to the device. When the EXTEST instruction is latched in the instruction register, the following actions occur. Once enabled through the update-IR state, the parallel outputs of all digital outputs are driven. The boundary scan test data register is connected between TDI and TDO. The capture-DR samples all digital inputs into the boundary scan test data register.

IDCODE: When the IDCODE instruction is latched into the parallel instruction register, the identification test data register is selected. The device identification code is loaded into the identification test data register on the rising edge of TCK following entry into the capture-DR state. Shift-DR is used to shift the identification code out serially through TDO. During test-logic-reset, the identification code is forced into the instruction register. The ID code always has a 1 in the LSB position. The next 11 bits identify the manufacturer's JEDEC number and number of continuation bytes followed by 16 bits for the device and 4 bits for the version. See Table 17.

Table 16. JTAG Instruction Set

| INSTRUCTION | BINARY CODE | SELECTED REGISTER/ACTION |
|----------------|-------------|--|
| BYPASS | 11111 | Bypass |
| IDCODE | 00000 | Identification |
| SAMPLE/PRELOAD | 00001 | Boundary scan |
| EXTEST | 00010 | Boundary scan |
| USERCODE | 00100 | User-code data |
| LOAD ADDRESS | 01000 | Memory address |
| READ | 01001 | Memory read |
| WRITE | 01010 | Memory write |
| REBOOT | 01100 | Resets the device |
| SAVE | 01101 | Stores current fault information in EEPROM |

EEPROM-Based System Monitors with Nonvolatile Fault Memory

Table 17. 32-Bit Identification Code

| MSB | | | | LSB |
|------------------|---------------------|---------------------------|---------------------|-----|
| Version (4 bits) | Device ID (16 bits) | Manufacturer ID (11 bits) | Fixed value (1 bit) | |
| 0000 | 0000000000000001 | 00011001011 | 1 | |

Table 18. 32-Bit User-Code Data

| MSB | | |
|--------------------|--------------------------------------|--|
| D.C. (don't cares) | I ² C/SMBus Slave Address | User identification (firmware version) |
| 0000000000000000 | See Table 15 | r5Eh[7:0] contents |

USERCODE: When the USERCODE instruction is latched into the parallel instruction register, the user-code data register is selected. The device user code is loaded into the user-code data register on the rising edge of TCK following entry into the capture-DR state. Shift-DR is used to shift the user code out serially through TDO. See Table 18.

LOAD ADDRESS: This is an extension to the standard IEEE 1149.1 instruction set to support access to the memory in the MAX16031/MAX16032. When the LOAD ADDRESS instruction is latched into the instruction register, TDI connects to TDO through the 8-bit memory address test data register during the shift-DR state.

READ: This is an extension to the standard IEEE 1149.1 instruction set to support access to the memory in the MAX16031/MAX16032. When the READ instruction is latched into the instruction register, TDI connects to TDO through the 8-bit memory read test data register during the shift-DR state.

WRITE: This is an extension to the standard IEEE 1149.1 instruction set to support access to the memory in the MAX16031/MAX16032. When the WRITE instruction is latched into the instruction register, TDI connects to TDO through the 8-bit memory write test data register during the shift-DR state.

REBOOT: This is an extension to the standard IEEE 1149.1 instruction set to initiate a software-controlled reset to the MAX16031/MAX16032. When the REBOOT instruction is latched into the instruction register, the MAX16031/MAX16032 reset and immediately begin their boot-up sequence.

SAVE: This is an extension to the standard IEEE 1149.1 instruction set that triggers a fault log. When the SAVE instruction is latched into the instruction register, the MAX16031/MAX16032 copy fault information from registers to EEPROM.

Boundary Scan

The boundary scan feature allows access to all the digital I/O connections of the MAX16031/MAX16032. If the sample/preload or the EXTEST instruction is loaded into the instruction register, TDI connects to TDO through the 198-bit boundary scan register. Each digital I/O pin corresponds to 1 bit (or 2 bits, in the case of the A0 and A1 pins) of the boundary scan register. The rest of the boundary scan bits are reserved and are loaded with zeros.

When the sample/preload instruction is executed, the current state of the digital outputs is latched into the boundary scan register and is shifted out through TDO. This instruction may be executed without interrupting normal operation of the part. When the EXTEST instruction is executed, the boundary scan register bits supersede the normal functionality of the I/O pins: an output mirrors the state of the corresponding boundary scan register bit.

Table 19 lists the function of each boundary scan register bit. Since the I²C address select pins have three possible states, 2 boundary scan register bits are required to represent them. These bits are defined in Table 20.

Applications Information

Layout and Bypassing

Bypass VCC, DBP, and ABP each with a 1μF capacitor to GND. Bypass RBP with a 2.2μF capacitor to GND. Avoid routing digital return currents through a sensitive analog area, such as an analog supply input return path or ABP's bypass capacitor ground connection. Use dedicated analog and digital ground planes.

EEPROM-Based System Monitors with Nonvolatile Fault Memory

Table 19. Boundary Cell Order

| BOUNDARY CELL NO. | DESCRIPTION/PIN |
|-------------------|----------------------------|
| 0–147 | Reserved |
| 148 | GPIO1 (output) |
| 149 | GPIO2 (output) |
| 150 | SDA (output) |
| 151 | $\overline{\text{ALERT}}$ |
| 152 | $\overline{\text{FAULT2}}$ |
| 153 | $\overline{\text{FAULT1}}$ |
| 154 | $\overline{\text{OVERT}}$ |
| 155 | $\overline{\text{RESET}}$ |
| 156 | $\overline{\text{OVERC}}$ |
| 157–182 | Reserved |
| 183 | GPIO2 (input) |
| 184 | GPIO1 (input) |
| 185 | SDA (input) |
| 186 | A0b |
| 187 | A0a |
| 188 | A1b |
| 189 | A1a |
| 190 | SCL |
| 191–197 | Reserved |

Table 20. Address Pin State Decode

| A0A A0B | A0 PIN STATE |
|---------|----------------|
| 0 0 | High impedance |
| 0 1 | Low |
| 1 0 | High |
| 1 1 | Not defined |

Chip Information

PROCESS: BICMOS

Package Information

For the latest package outline information and land patterns (footprints), go to www.maxim-ic.com/packages. Note that a “+”, “#”, or “-” in the package code indicates RoHS status only. Package drawings may show a different suffix character, but the drawing pertains to the package regardless of RoHS status.

| PACKAGE TYPE | PACKAGE CODE | OUTLINE NO. | LAND PATTERN NO. |
|--------------|--------------|-------------------------|-------------------------|
| 48 TQFN-EP | T4877+6 | 21-0144 | 90-0132 |

EEPROM-Based System Monitors with Nonvolatile Fault Memory

Revision History

| REVISION NUMBER | REVISION DATE | DESCRIPTION | PAGES CHANGED |
|------------------------|----------------------|--|----------------------|
| 0 | 7/07 | Initial release | — |
| 1 | 10/07 | Revised the <i>Ordering Information</i> | 1 |
| 2 | 6/10 | Revised the <i>Pin Description</i> | 11 |
| 3 | 9/10 | Changed the minimum reference voltage specification in the <i>Electrical Characteristics</i> section | 3 |
| 4 | 8/11 | Revised the Current Monitoring section and Table 6 | 19, 21 |

MAX16031/MAX16032

Maxim cannot assume responsibility for use of any circuitry other than circuitry entirely embodied in a Maxim product. No circuit patent licenses are implied. Maxim reserves the right to change the circuitry and specifications without notice at any time.

Maxim Integrated Products, 120 San Gabriel Drive, Sunnyvale, CA 94086 408-737-7600 _____ **41**