

Level Translating Fast-Mode Plus I²C-bus/SMBus Repeater

Features

- ➔ 2-channel, bidirectional buffer isolates capacitance and allows 540pF on either side of the device at 1 MHz, and up to 4000 pF at lower speeds
- ➔ Voltage level translation from 0.6V to 5.5V and from 2.2V to 5.5V
- ➔ Footprint and functional replacement for PI4ULS5V212 at Fast-mode speeds
- ➔ Port A operating supply voltage range of 0.6V to 5.5V with normal levels ($0.4V_{CC(A)} + 0.8V \leq V_{CC(B)}$)
- ➔ Port B operating supply voltage range of 2.2V to 5.5V with static offset level
- ➔ 5V-tolerant I²C-bus and enable pins
- ➔ 0 Hz to 1 MHz clock frequency (the maximum system operating frequency may be less than 1MHz because of the delays added by the repeater)
- ➔ Active HIGH repeater enable input referenced to $V_{CC(B)}$
- ➔ Open-drain input/outputs
- ➔ Latching-free operation
- ➔ Supports arbitration and clock stretching across the repeater
- ➔ Accommodates Standard-mode, Fast-mode, and Fast-mode Plus I²C-bus devices; SMBus (standard and high power mode); PMBus; and multiple masters
- ➔ Powered-off high-impedance I²C-bus pins
- ➔ ESD-protection exceeds 8000V HBM per JESD22-A114
- ➔ Totally Lead-Free & Fully RoHS Compliant (Notes 1 & 2)
- ➔ Halogen- and Antimony-Free. "Green" Device (Note 3)
- ➔ For automotive applications requiring specific change control (i.e. parts qualified to AEC-Q100/101/200, PPAP capable, and manufactured in IATF 16949 certified facilities), please [contact us](mailto:contact_us) or your local Diodes representative.
- ➔ Package:
 - 8-pin, MSOP-8 (U)

Description

The PI4ULS5V212 is a CMOS integrated circuit intended for Fast-mode Plus (Fm+) I²C-bus or SMBus applications. It can provide level shifting between low voltages (down to 0.6V) and higher voltages (2.2V to 5.5V) in mixed-mode applications.

The PI4ULS5V212 enables the system designer to isolate two halves of a bus for both voltage and capacitance, accommodating more I²C devices or longer trace length. It also permits extension of the I²C-bus by providing bidirectional buffering for both the data (SDA) and the clock (SCL) lines, thus enabling two buses of 540 pF at 1 MHz, or up to 4000 pF at lower speeds. The SDA and SCL pins are overvoltage-tolerant and are high-impedance when the PI4ULS5V212 is unpowered.

The 2.2V to 5.5V bus port B drivers have the static level offset, while the adjustable voltage bus port A drivers eliminate the static offset voltage. This results in a LOW on the port B translating into a nearly 0V LOW on the port A, which accommodates the smaller voltage swings of lower voltage logic. The EN pin is referenced to $V_{CC(B)}$ and can also be used to turn the drivers on and off under system control.

Block Diagram

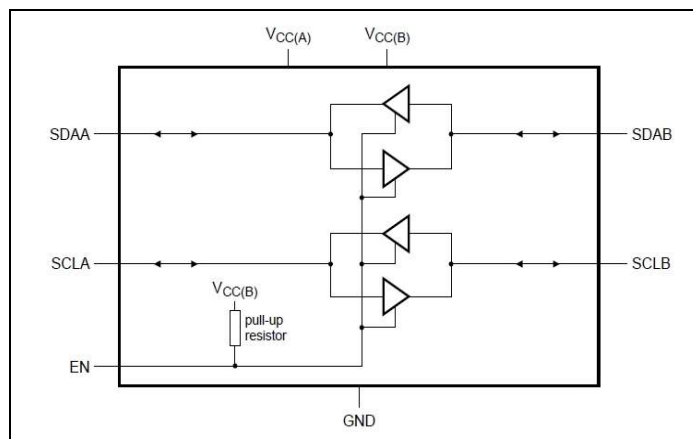
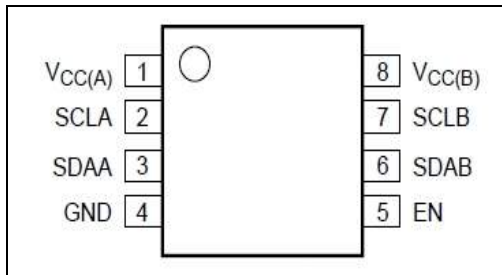

Figure 1: Block Diagram

EN	Function
H	SCLA = SCLB; SDAA = SDAB;
L	Disabled

Notes:
 1. No purposely added lead. Fully EU Directive 2002/95/EC (RoHS), 2011/65/EU (RoHS 2) & 2015/863/EU (RoHS 3) compliant.
 2. See <https://www.diodes.com/quality/lead-free/> for more information about Diodes Incorporated's definitions of Halogen- and Antimony-free, "Green" and Lead-free.
 3. Halogen- and Antimony-free "Green" products are defined as those which contain <900ppm bromine, <900ppm chlorine (<1500ppm total Br + Cl) and <1000ppm antimony compounds.

Pin Configuration



(Top View)

Pin Description

Pin#	Pin Name	Description
1	V _{CC(A)}	port A supply voltage (0.6V to 5.5V)
2	SCLA	serial clock port A bus
3	SDAA	serial data port A bus
4	GND	supply ground (0 V)
5	EN	active HIGH repeater enable input
6	SDAB	serial data port B bus
7	SCLB	serial clock port B bus
8	V _{CC(B)}	port B supply voltage (2.2V to 5.5V)

Maximum Ratings

Storage Temperature.....	-55°C to +125°C
Supply Voltage port B.....	-0.5V to +6.0V
Supply Voltage port A.....	-0.5V to +6.0V
DC Input Voltage.....	-0.5V to +6.0V
Control Input Voltage (EN).....	-0.5V to +6.0V
Total Power Dissipation.....	100mW
Input /Output Current (port A&B).....	50mA
Input current (EN, VCCA, VCCB, GND).....	50mA
ESD: HBM Mode.....	8000V

Note:

Stresses greater than those listed under MAXIMUM RATINGS may cause permanent damage to the device. This is a stress rating only and functional operation of the device at these or any other conditions above those indicated in the operational sections of this specification is not implied. Exposure to absolute maximum rating conditions for extended periods may affect reliability.

DC Electrical Characteristics

$V_{CC(A)} = 0.6V$ to $5.5V^{(1)}$; $V_{CC(B)} = 2.2V$ to $5.5V$; $GND = 0V$; $T_A = -40^{\circ}C$ to $+85^{\circ}C$; unless otherwise noted.

Symbol	Parameter	Conditions	Min.	Typ.	Max.	Unit
$V_{CC(B)}$	supply voltage port B	-	2.2	-	5.5	V
$V_{CC(A)}$	supply voltage port A	-	0.6	-	5.5	V
$I_{CC(A)}$	supply current on pin $V_{CC(A)}$	$V_{CC(A)} = 0.95V$	-	-	8	μA
		$V_{CC(A)} = 5.5V$	-	-	50	
$I_{CCH(B)}$	port B HIGH-level supply current	$V_{CC(B)} = 5.5V$ $SDAn = SCLn = V_{CC(n)}$	-	0.8	2.5	m A
$I_{CCL(B)}$	port B LOW-level supply current	$V_{CC(B)} = 5.5V$; one SDA and one SCL = GND; other SDA and SCL open (with pull-up resistors)	-	1.7	2.9	mA
$I_{QVC(B)}$	Quiescent current on $V_{CC(B)}$	EN=GND; $V_{CC(B)}=5.5V$	-	0.4	0.8	mA

Note:

(1) $V_{CC(A)}$ may be as high as 5.5 V for over voltage tolerance but $0.4V_{CC(A)} + 0.8V \leq V_{CC(B)}$ for the channels to be enabled and functional normally.

DC Electrical Characteristics

$V_{CC(A)} = 0.6V$ to $5.5V^{(5)}$; $V_{CC(B)} = 2.2V$ to $5.5V$; $GND = 0V$; $T_A = -40^{\circ}C$ to $+85^{\circ}C$; Typical values measured with $V_{CC(A)} = 0.95V$ and $V_{CC(B)} = 2.5V$, unless otherwise noted.

Symbol	Parameter	Test Conditions	Min.	Typ.	Max.	Unit
Input and output SDAB and SCLB						
V_{IH}	HIGH-level input voltage	-	$0.7V_{CC(B)}$	-	5.5	V
V_{IL}	LOW-level input voltage	-	-0.5	-	+0.4	V
V_{IK}	Input clamping voltage	$I_I = -18$ mA	-1.2	-	-	V
I_{LI}	Input leakage current	$V_I = 5.5V$	-	-	± 1	μA
I_{IL}	LOW-level input current	SDA, SCL; $V_I = 0.2$ V	-	-	10	μA
V_{OL}	LOW-level output voltage	$I_{OL} = 150\mu A$ at $V_{CC(B)} = 2.2V^{(1)}$	0.47	-	-	V
		$I_{OL} = 13mA$ at $V_{CC(B)} = 2.2V^{(2)}$	-	0.54	0.60	V
$V_{OL} - V_{IL}$	Difference between LOW-level output and LOW-level input voltage contention	V_{OL} at $I_{OL} = 1$ mA; guaranteed by design	60	90	160	mV
C_{io}	Input/output capacitance	$V_I = 3V$ or $0V$; $V_{CC(B)} = 3.3V$; EN = LOW	-	7	10	pF
		$V_I = 3V$ or $0V$; $V_{CC(B)} = 0V$	-	7	10	pF
Input and output SDAA and SCLA						
V_{IH}	HIGH-level input voltage	-	$0.7V_{CC(A)}$	-	5.5	V
V_{IL}	LOW-level input voltage	-	$-0.5^{(3)}$	-	$+0.33V_{CC(A)}^{(4)}$	V
V_{IK}	Input clamping voltage	$I_I = -18$ mA	-1.2	-	-	V
I_{LI}	Input leakage current	$V_I = 5.5V$	-	-	± 1	μA
I_{IL}	LOW-level input current	SDA, SCL; $V_I = 0.2$ V	-	-	10	μA
V_{OL}	LOW-level output voltage	$I_{OL} = 13mA$ at $V_{CC(B)} = 2.2V$	-	0.1	0.2	V
C_{io}	Input/output capacitance	$V_I = 3V$ or $0V$; $V_{CC(B)} = 3.3V$; EN = LOW	-	7	10	pF
		$V_I = 3V$ or $0V$; $V_{CC(B)} = 0V$	-	7	10	pF
Enable						
V_{IH}	HIGH-level input voltage	-	$0.7V_{CC(B)}$	-	5.5	V
V_{IL}	LOW-level input voltage	-	-0.5	-	$+0.3V_{CC(B)}$	V
I_{LI}	Input leakage current	$V_I = V_{CC(B)}$	-1	-	+1	μA
I_{IL}	LOW-level input current	$V_I = 0.2V$, EN; $V_{CC(B)} = 2.2V$;	-18	-7	-	μA
C_{io}	Input capacitance	$V_I = V_{CC(B)}$	-	6	-	pF

Note:

- (1) Pull-up should result in $I_{OL} \geq 150\mu A$.
- (2) Guaranteed by design and characterization.
- (3) V_{IL} for port A with envelope noise must be below $0.33V_{CC(A)}$ for stable performance.
- (4) When $V_{CC(A)}$ is less than 1V, care is required to make certain that the system ground offset and noise is minimized such that there is reasonable difference between the V_{IL} present at the PI4ULS5V212 A-side input and the $0.33V_{CC(A)}$ input threshold.
- (5) $V_{CC(A)}$ may be as high as 5.5 V for over voltage tolerance but $0.4V_{CC(A)} + 0.8V \leq V_{CC(B)}$ for the channels to be enabled and functional normally.

Figure 2:
Port B V_{OL} versus I_{OL}

Condition:
 $V_{CCB}=2.2V, T_A=25^{\circ}C$
 $V_{CCB}=2.2V, T_A=85^{\circ}C$
 $V_{CCB}=3V, T_A=85^{\circ}C$

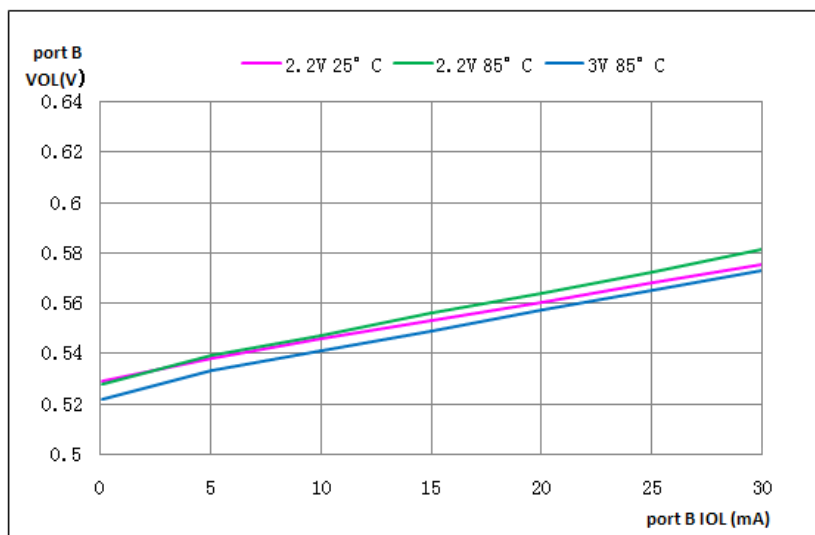

Figure 3:
Port A V_{OL} versus I_{OL}

Condition:
 $V_{CCA}=2.2V, T_A=25^{\circ}C$
 $V_{CCA}=2.2V, T_A=85^{\circ}C$
 $V_{CCB}=3V, t_{amb}=25^{\circ}C$

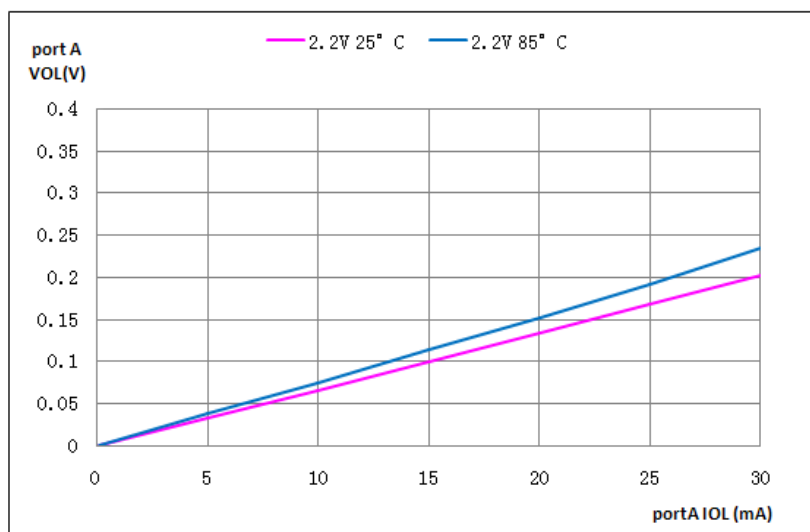
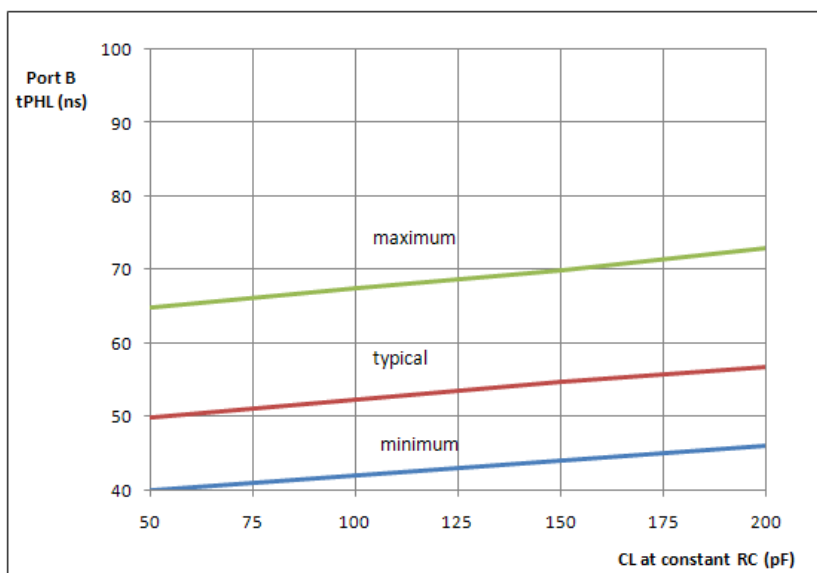

Figure 4:
Nominal port B t_{PHL} with load capacitance at constant RC

Condition:
 $RC = 67.5 ns, V_{CC(A)} = 0.95 V,$
 $V_{CC(B)} = 2.5 V, T_A=25^{\circ}C$



Dynamic Characteristics

$V_{CC(A)} = 0.6V$ to $5.5V^{(8)}$; $V_{CC(B)} = 2.2V$ to $5.5V$; $GND = 0V$; $T_A = -40^{\circ}C$ to $+85^{\circ}C$; Typical values measured with $V_{CC(A)} = 0.95V$ and $V_{CC(B)} = 2.5V$, unless otherwise noted.⁽¹⁾⁽²⁾

Symbol	Parameter	Conditions	Min.	Typ. ^[3]	Max.	Unit
t_{PLH}	LOW-to-HIGH propagation delay	B-side to A-side	-	-90	-165	ns
$t_{PLH2}^{[4]}$	LOW-to-HIGH propagation delay2	B-side to A-side	-	94	130	ns
t_{PHL}	HIGH-to-LOW propagation delay	B-side to A-side	-	76	152	ns
$t_{TLH}^{[5]}$	LOW-to-HIGH transition time	A-side	-	60	-	ns
SRf	Falling slew rate	port A; $0.7V_{CC(A)}$ to $0.3V_{CC(A)}$	-	0.037	-	V/ns
$t_{PLH}^{[6]}$	LOW-to-HIGH propagation delay	A-side to B-side	-	115	210	ns
$t_{PHL}^{[6]}$	HIGH-to-LOW propagation delay	A-side to B-side	-	50	173	ns
t_{TLH}	LOW-to-HIGH transition time	B-side	-	60	-	ns
t_{THL}	HIGH-to-LOW transition time	B-side	-	30	76	ns
$t_{en}^{[7]}$	Enable time	Quiescent $-0.3 V$; EN HIGH to enable;	-	-	100	ns
$t_{dis}^{[7]}$	Disable time	quiescent $+0.3 V$; EN LOW to disable;	-	-	100	ns

Note:

- (1) Times are specified with loads of 1.35 k Ω pull-up resistance and 50 pF load capacitance on port A and port B, and a falling edge slew rate of 0.05 V/ns input signals.
- (2) Pull-up voltages are $V_{CC(A)}$ on port A and $V_{CC(B)}$ on port B.
- (3) Typical values were measured with $V_{CC(A)} = 0.95 V$, $V_{CC(B)} = 2.5V$ at $T_A = 25^{\circ}C$, unless otherwise noted.
- (4) The t_{PLH2} delay data from port B to port A is measured at 0.45 V on port B to $0.5V_{CC(A)}$ on port A.
- (5) The t_{TLH} of the bus is determined by the pull-up resistance (1.35 k Ω) and the total capacitance (50 pF).
- (6) The proportional delay data from port A to port B is measured at $0.5V_{CC(A)}$ on port A to $0.5V_{CC(B)}$ on port B.
- (7) The enable pin, EN, should only change state when the global bus and the repeater port are in an idle state.
- (8) $V_{CC(A)}$ may be as high as 5.5 V for over voltage tolerance but $0.4V_{CC(A)} + 0.8 V \leq V_{CC(B)}$ for the channels to be enabled and functional normally.

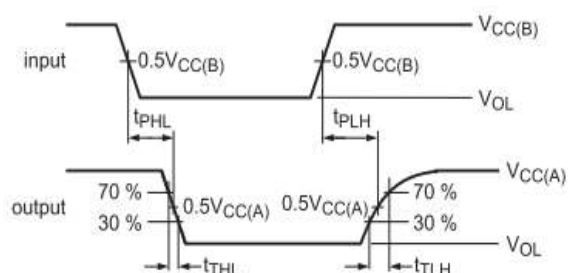

Figure 5: Propagation Delay and Transition Times B→A

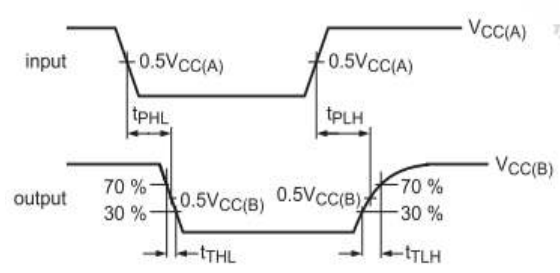

Figure 6: Propagation Delay and Transition Times A→B

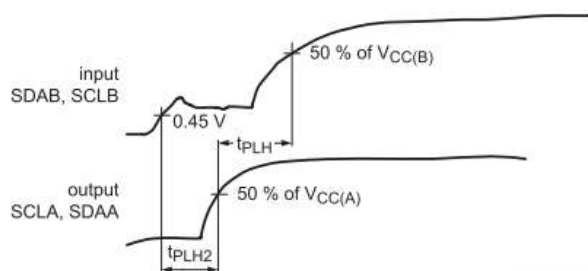
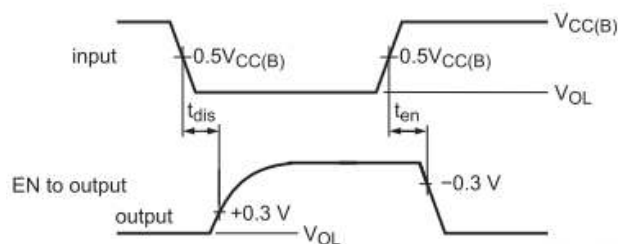
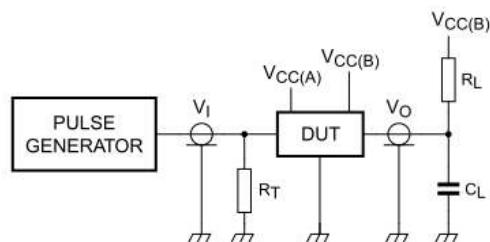

Figure 7: Propagation Delay and Enable and disable time





R_L = load resistor; 1.35 k Ω on port B
 C_L = load capacitance includes jig and probe capacitance; 50 pF
 R_T = termination resistance should be equal to Z_0 of pulse generators

Figure 8: Test Circuit

Functional Description

The PI4ULS5V212 enables the I²C-bus or SMBus translation down to $V_{CC(A)}$ as low as 0.6V without degradation of system performance. The PI4ULS5V212 contains two bidirectional open-drain buffers specifically designed to support up-translation/down-translation between the low voltage (as low as 0.6V) and a 2.5V, 3.3V, or 5V I²C-bus or SMBus. All inputs and I/Os are overvoltage-tolerant to 5.5V, even when the device is unpowered ($V_{CC(B)}$ and/or $V_{CC(A)} = 0V$).

The PI4ULS5V212 includes a power-up circuit that keeps the output drivers turned off until $V_{CC(B)}$ is above 2.2V, and until after the internal reference circuits have settled at about 400 μ s and the $V_{CC(A)}$ is above 0.6V. $V_{CC(B)}$, and $V_{CC(A)}$ can be applied in any sequence at power-up.

The PI4ULS5V212 includes a $V_{CC(A)}$ overvoltage disable function that turns the channel off if $0.4V_{CC(A)} + 0.8V > V_{CC(B)}$. The PI4ULS5V212 logic and all I/Os are powered by the $V_{CC(B)}$ pin.

The B-side drivers operate from 2.2V to 5.5V. The output low level of port B internal buffer is approximately 0.55 V, while the input voltage must be 90mV lower (0.45V), or even more lower. The nearly 0.5V low signal is called a buffered low. When the B-side I/O is driven low internally, the low is not recognized as a low by the input. This feature prevents a lockup condition from occurring when the input low condition is released. This type of design on B port prevents it from being used in series with another PI4ULS5V212 (B side) or similar devices, because they don't recognize buffer low signals as a valid low.

The A-side drivers operate from 0.6V to 5.5 V. The output low level of port A internal buffer is nearly 0V, while the input low level is set at $0.35V_{CC(A)}$ to accommodate the need for a lower LOW level in systems where the low voltage side supply voltage is as low as 0.6V. Port A of two or more PI4ULS5V212s can be connected together to allow a star topography with port A on the common bus. And port A can be connected directly to any other buffer with static or dynamic offset voltage. Multiple PI4ULS5V212s can be connected in series, port A to port B, with no build-up in offset voltage with only time of flight delays to consider.

After power-up and with the EN HIGH, a LOW level on port A (below $0.3V_{CC(A)}$) turns the corresponding port B driver (either SDA or SCL) on and drives port B down to about 0.55 V. When port A rises above $0.3V_{CC(A)}$, the port B pull-down driver is turned off and the external pull-up resistor pulls the pin HIGH. When port B falls first and goes below 0.4 V, the port A driver is turned on and port A pulls down to about 0 V. The port A pull-down is not enabled unless the port B voltage goes below 0.4 V. If the port B low voltage goes below 0.4 V, the port B pull-down driver is enabled and port B will only be able to rise to 0.55 V until port A rises above $0.3V_{CC(A)}$, then port B will continue to rise being pulled up by the external pull-up resistor. The $V_{CC(A)}$ is only used to provide the $0.35V_{CC(A)}$ reference to the port A input comparators and for the power good detect circuit. The PI4ULS5V212 logic and all I/Os are powered by the $V_{CC(B)}$ pin.

The EN pin is active HIGH with thresholds referenced to $V_{CC(B)}$ and an internal pull-up to $V_{CC(B)}$ that maintains the device active unless the user selects to disable the repeater to isolate a badly behaved slave on power-up until after the system power-up reset. It should never change state during an I²C-bus operation because disabling during a bus operation will hang the bus and enabling part way through a bus cycle could confuse the I²C-bus parts being enabled. The enable does not switch the internal reference circuits so the 400 μ s delay is only seen when $V_{CC(B)}$ comes up. The enable pin should only change state when the global bus and the repeater port are in an idle state to prevent system failures.

As with the standard I²C-bus system, pull-up resistors are required to provide the logic HIGH levels on the buffered bus (standard open-collector configuration of the I²C-bus). The size of these pull-up resistors depends on the system, but each side of the repeater must have a pull-up resistor. This part designed to work with Standard mode, Fast-mode and Fast-mode Plus I²C-bus devices in addition to SMBus devices. Standard mode and Fast-mode I²C-bus devices only specify 3mA output drive; this limits the termination current to 3mA in a generic I²C-bus system where Standard-mode devices, Fast-mode devices and multiple masters are possible. When only Fast-mode Plus devices are used with 30mA at 5 V drive strength, then lower value pull-up resistors can be used. The B-side RC should not be less than 67.5 ns because shorter RCs

increase the turnaround bounce when the B-side transitions from being externally driven to pulled down by its offset buffer.

Application Information

A typical application is shown in Figure 9. In this example, the system master is running on a 3.3 V I²C-bus while the slave is connected to a 1.2 V bus. Both buses run at 1MHz. Master devices can be placed on either bus.

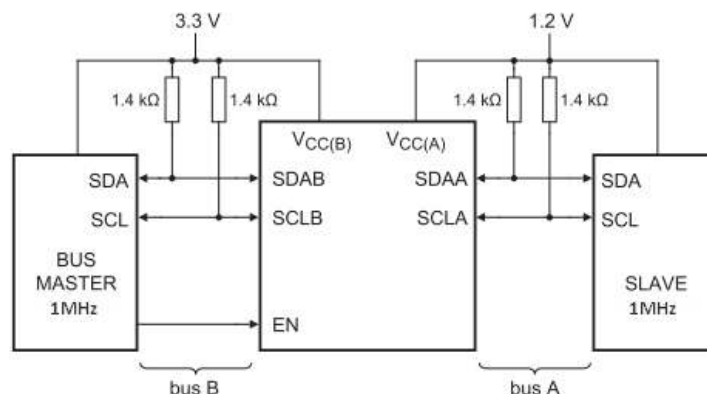

Figure 9: Typical Application

The PI4ULS5V212 is 5V-tolerant, so it does not require any additional circuitry to translate between 0.6V to 5.5V bus voltages and 2.2 V to 5.5 V bus voltages.

When port A of the PI4ULS5V212 is pulled LOW by a driver on the I²C-bus, a comparator detects the falling edge when it goes below $0.3V_{CC(A)}$ and causes the internal driver on port B to turn on, causing port B to pull down to about 0.5 V. When port B of the PI4ULS5V212 falls, first a CMOS hysteresis type input detects the falling edge and causes the internal driver on port A to turn on and pull the port A pin down to ground. In order to illustrate what would be seen in a typical application, refer to Figure 9 and Figure 10. If the bus master in Figure 9 were to write to the slave through the PI4ULS5V212, waveforms shown in Figure 9 would be observed on the A bus. This looks like a normal I²C-bus transmission except that the HIGH level may be as low as 0.6V, and the turn on and turn off of the acknowledge signals are slightly delayed.

On the B bus side of the PI4ULS5V212, the clock and data lines would have a positive offset from ground equal to the V_{OL} of the PI4ULS5V212. After the eighth clock pulse, the data line will be pulled to the V_{OL} of the slave device which is very close to ground in this example. At the end of the acknowledge, the level rises only to the LOW level set by the driver in the PI4ULS5V212 for a short delay while the A bus side rises above $0.3V_{CC(A)}$ then it continues HIGH. It is important to note that any arbitration or clock stretching events require that the LOW level on the B bus side at the input of the PI4ULS5V212 (V_{IL}) be at or below 0.4 V to be recognized by the PI4ULS5V212 and then transmitted to the A bus side.

Multiple PI4ULS5V212 port A sides can be connected in a star configuration (Figure 10), allowing all nodes to communicate with each other.

Multiple PI4ULS5V212s can be connected in series as long as port A is connected to port B (Figure 11). I²C-bus slave devices can be connected to any of the bus segments. The number of devices that can be connected in series is limited by repeater delay/time-of-flight considerations on the maximum bus speed requirements.

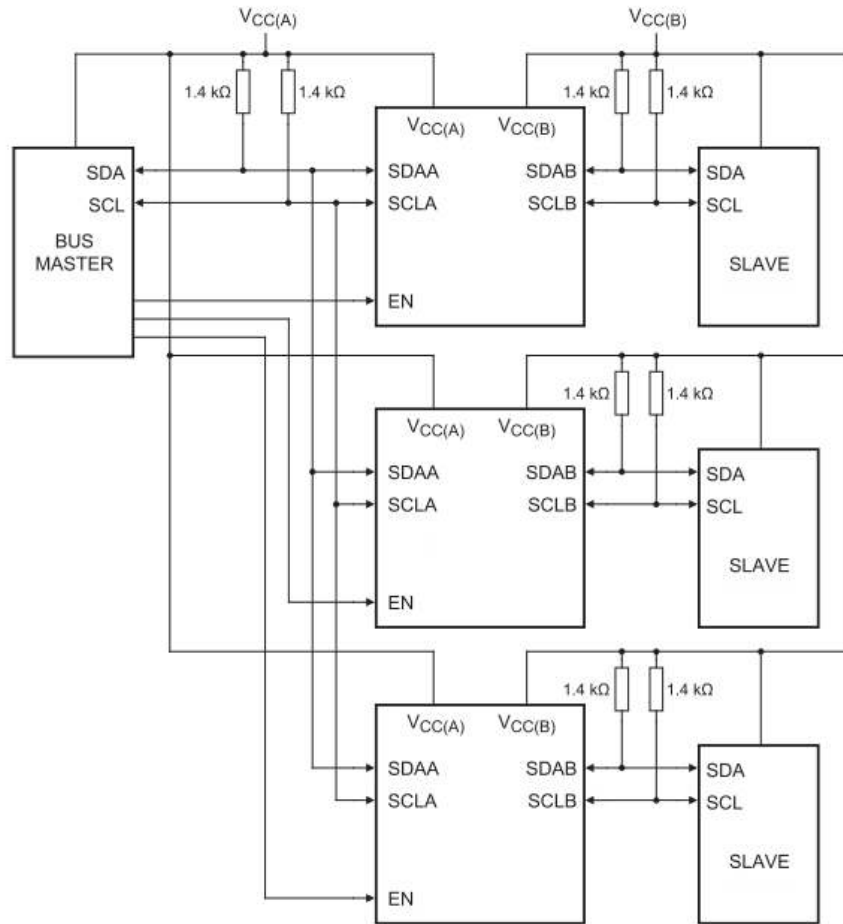

Figure 10: Typical Star Application

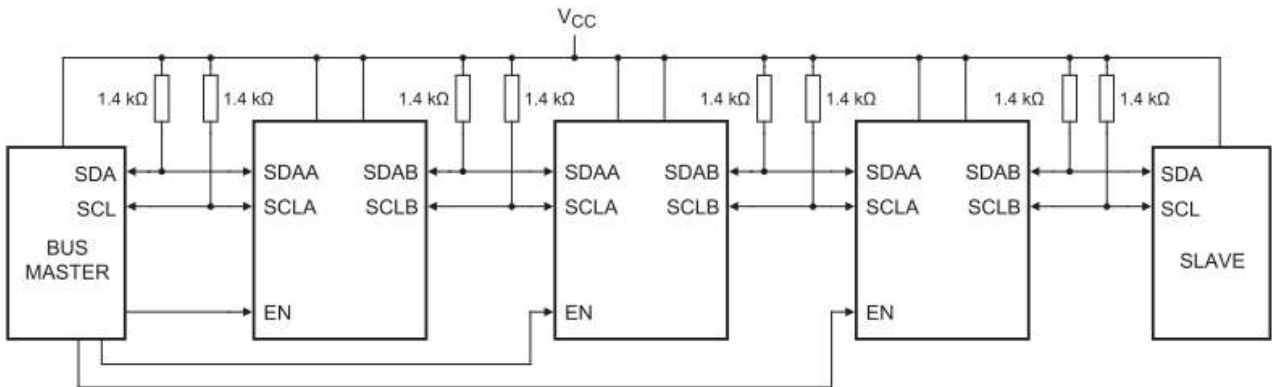

Figure 11: Typical Series Application

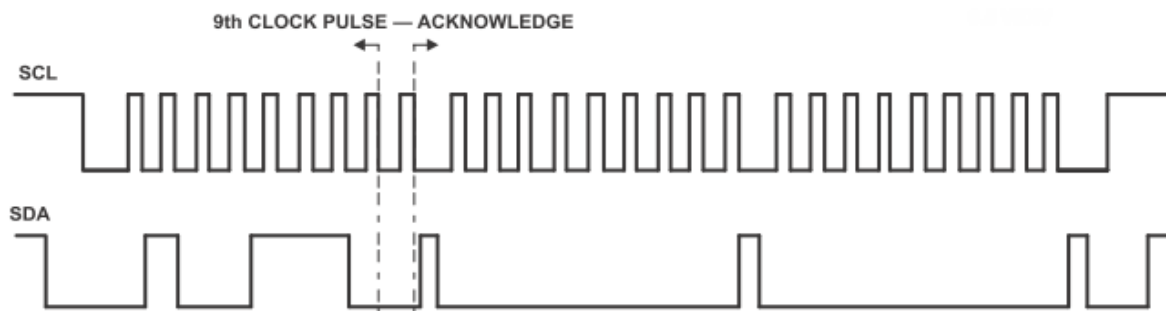

Figure 12: Bus A (0.6V to 5.5V Bus) Waveform

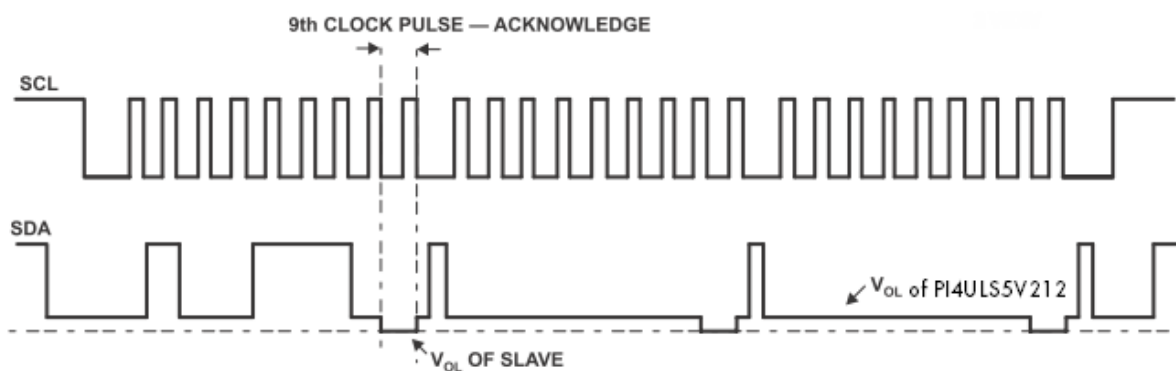
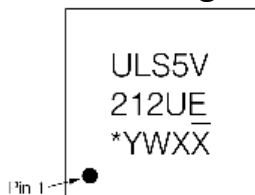

Figure 13: Bus B (2.2V to 5.5V Bus) Waveform

Part Marking



*: Die Rev

Y: Date Code (Year)

W: Date Code (Workweek)

1st X: Assembly Site Code

2nd X: Fab Site Code

Bar above Fab Code means Cu wire

Packaging Mechanical
8-MSOP (U)

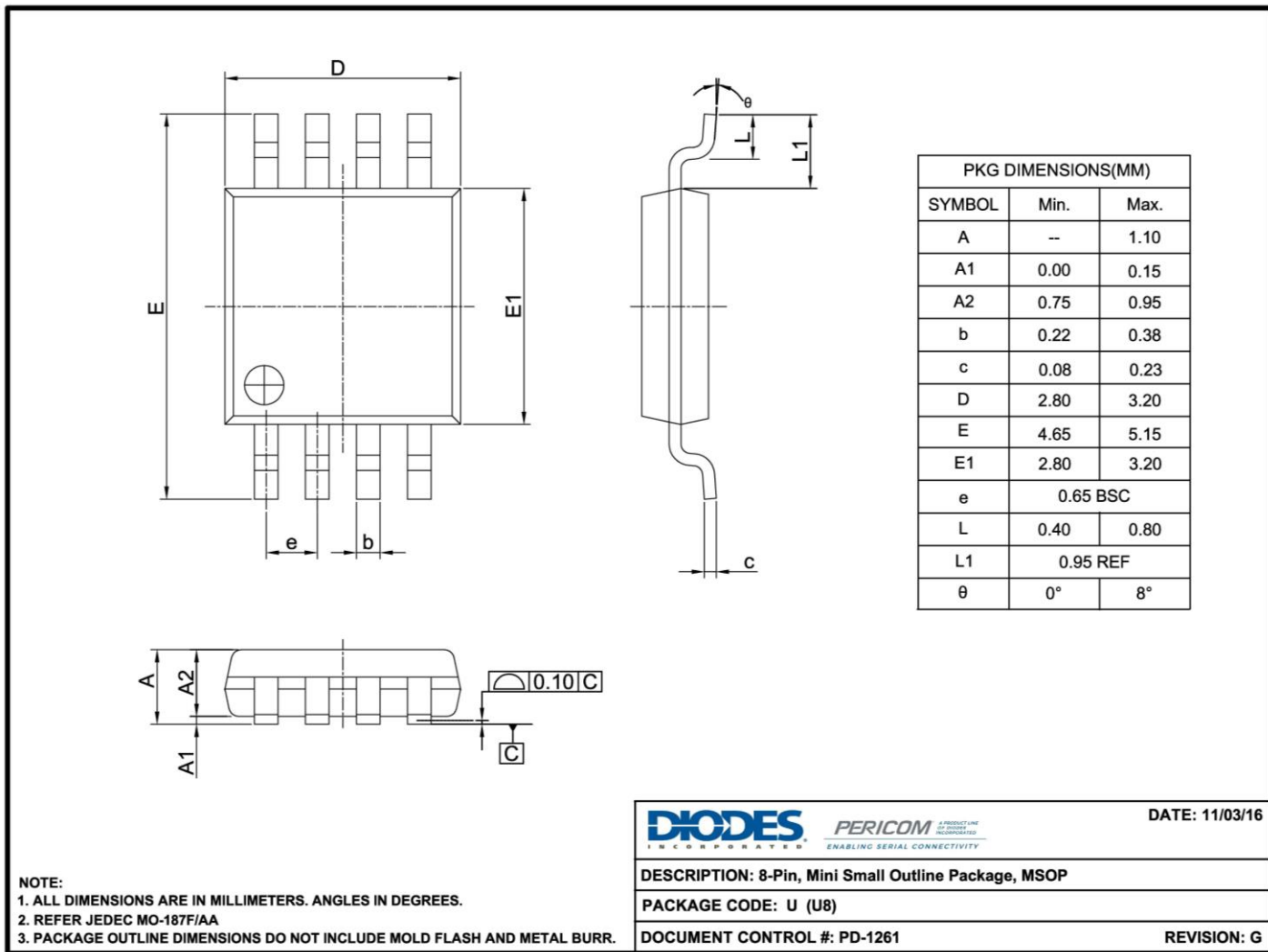

For latest package info, please check:
<http://www.diodes.com/design/support/packaging/pericom-packaging/packaging-mechanicals-and-thermal-characteristics/>

Ordering Information

Part Numbers	Package Code	Package Description
PI4ULS5V212UEX	U	8-pin, Mini Small Outline Package (MSOP)

- Notes:**
- No purposely added lead. Fully EU Directive 2002/95/EC (RoHS), 2011/65/EU (RoHS 2) & 2015/863/EU (RoHS 3) compliant.
 - See <https://www.diodes.com/quality/lead-free/> for more information about Diodes Incorporated's definitions of Halogen- and Antimony-free, "Green" and Lead-free.
 - Halogen- and Antimony-free "Green" products are defined as those which contain <900ppm bromine, <900ppm chlorine (<1500ppm total Br + Cl) and <1000ppm antimony compounds.
 - E = Pb-free and Green
 - X suffix = Tape/Reel

IMPORTANT NOTICE

1. DIODES INCORPORATED AND ITS SUBSIDIARIES (“DIODES”) MAKE NO WARRANTY OF ANY KIND, EXPRESS OR IMPLIED, WITH REGARDS TO ANY INFORMATION CONTAINED IN THIS DOCUMENT, INCLUDING, BUT NOT LIMITED TO, THE IMPLIED WARRANTIES OF MERCHANTABILITY, FITNESS FOR A PARTICULAR PURPOSE OR NON-INFRINGEMENT OF THIRD PARTY INTELLECTUAL PROPERTY RIGHTS (AND THEIR EQUIVALENTS UNDER THE LAWS OF ANY JURISDICTION).
2. The Information contained herein is for informational purpose only and is provided only to illustrate the operation of Diodes products described herein and application examples. Diodes does not assume any liability arising out of the application or use of this document or any product described herein. This document is intended for skilled and technically trained engineering customers and users who design with Diodes products. Diodes products may be used to facilitate safety-related applications; however, in all instances customers and users are responsible for (a) selecting the appropriate Diodes products for their applications, (b) evaluating the suitability of the Diodes products for their intended applications, (c) ensuring their applications, which incorporate Diodes products, comply the applicable legal and regulatory requirements as well as safety and functional-safety related standards, and (d) ensuring they design with appropriate safeguards (including testing, validation, quality control techniques, redundancy, malfunction prevention, and appropriate treatment for aging degradation) to minimize the risks associated with their applications.
3. Diodes assumes no liability for any application-related information, support, assistance or feedback that may be provided by Diodes from time to time. Any customer or user of this document or products described herein will assume all risks and liabilities associated with such use, and will hold Diodes and all companies whose products are represented herein or on Diodes’ websites, harmless against all damages and liabilities.
4. Products described herein may be covered by one or more United States, international or foreign patents and pending patent applications. Product names and markings noted herein may also be covered by one or more United States, international or foreign trademarks and trademark applications. Diodes does not convey any license under any of its intellectual property rights or the rights of any third parties (including third parties whose products and services may be described in this document or on Diodes’ website) under this document.
5. Diodes products are provided subject to Diodes’ Standard Terms and Conditions of Sale (<https://www.diodes.com/about/company/terms-and-conditions/terms-and-conditions-of-sales/>) or other applicable terms. This document does not alter or expand the applicable warranties provided by Diodes. Diodes does not warrant or accept any liability whatsoever in respect of any products purchased through unauthorized sales channel.
6. Diodes products and technology may not be used for or incorporated into any products or systems whose manufacture, use or sale is prohibited under any applicable laws and regulations. Should customers or users use Diodes products in contravention of any applicable laws or regulations, or for any unintended or unauthorized application, customers and users will (a) be solely responsible for any damages, losses or penalties arising in connection therewith or as a result thereof, and (b) indemnify and hold Diodes and its representatives and agents harmless against any and all claims, damages, expenses, and attorney fees arising out of, directly or indirectly, any claim relating to any noncompliance with the applicable laws and regulations, as well as any unintended or unauthorized application.
7. While efforts have been made to ensure the information contained in this document is accurate, complete and current, it may contain technical inaccuracies, omissions and typographical errors. Diodes does not warrant that information contained in this document is error-free and Diodes is under no obligation to update or otherwise correct this information. Notwithstanding the foregoing, Diodes reserves the right to make modifications, enhancements, improvements, corrections or other changes without further notice to this document and any product described herein. This document is written in English but may be translated into multiple languages for reference. Only the English version of this document is the final and determinative format released by Diodes.
8. Any unauthorized copying, modification, distribution, transmission, display or other use of this document (or any portion hereof) is prohibited. Diodes assumes no responsibility for any losses incurred by the customers or users or any third parties arising from any such unauthorized use.

Copyright © 2021 Diodes Incorporated

www.diodes.com