

LOC		DIST		REVISIONS			
FT	0	P	LTN	DESCRIPTION	DATE	DWN	APVD
		G1		REVISED PER ECO-16-004800	10SEP2016	NK	MZ

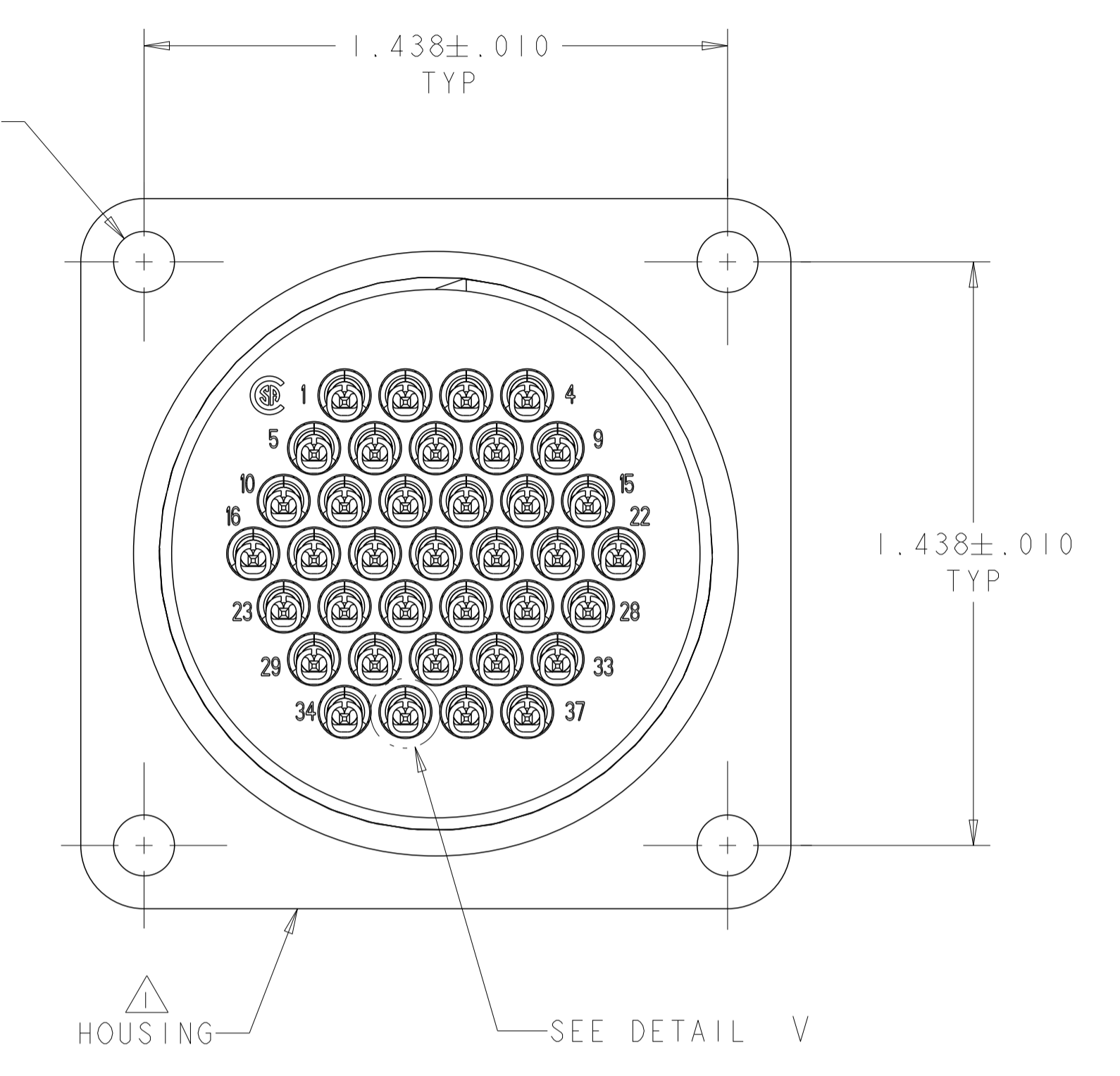

- 1 HOUSING: THERMOPLASTIC, COLOR: BLACK.
- 2 CONTACT:
 BODY - .000100 MIN TIN-LEAD OVER .000050 MIN NICKEL.
 POST - .000100 MIN TIN-LEAD OVER .000050 MIN NICKEL.
- 3 CONTACT:
 BODY - .000100 MIN TIN OVER .000050 MIN NICKEL.
 POST - .000100 MIN TIN OVER .000050 MIN NICKEL.
- 4 PERIPHERAL SEAL: ELASTOMER, COLOR: GRAY.
- 5 OBSOLETE PARTS: OBSOLETE CIS STREAMLINING PER D.RENAUD/D.SINISI

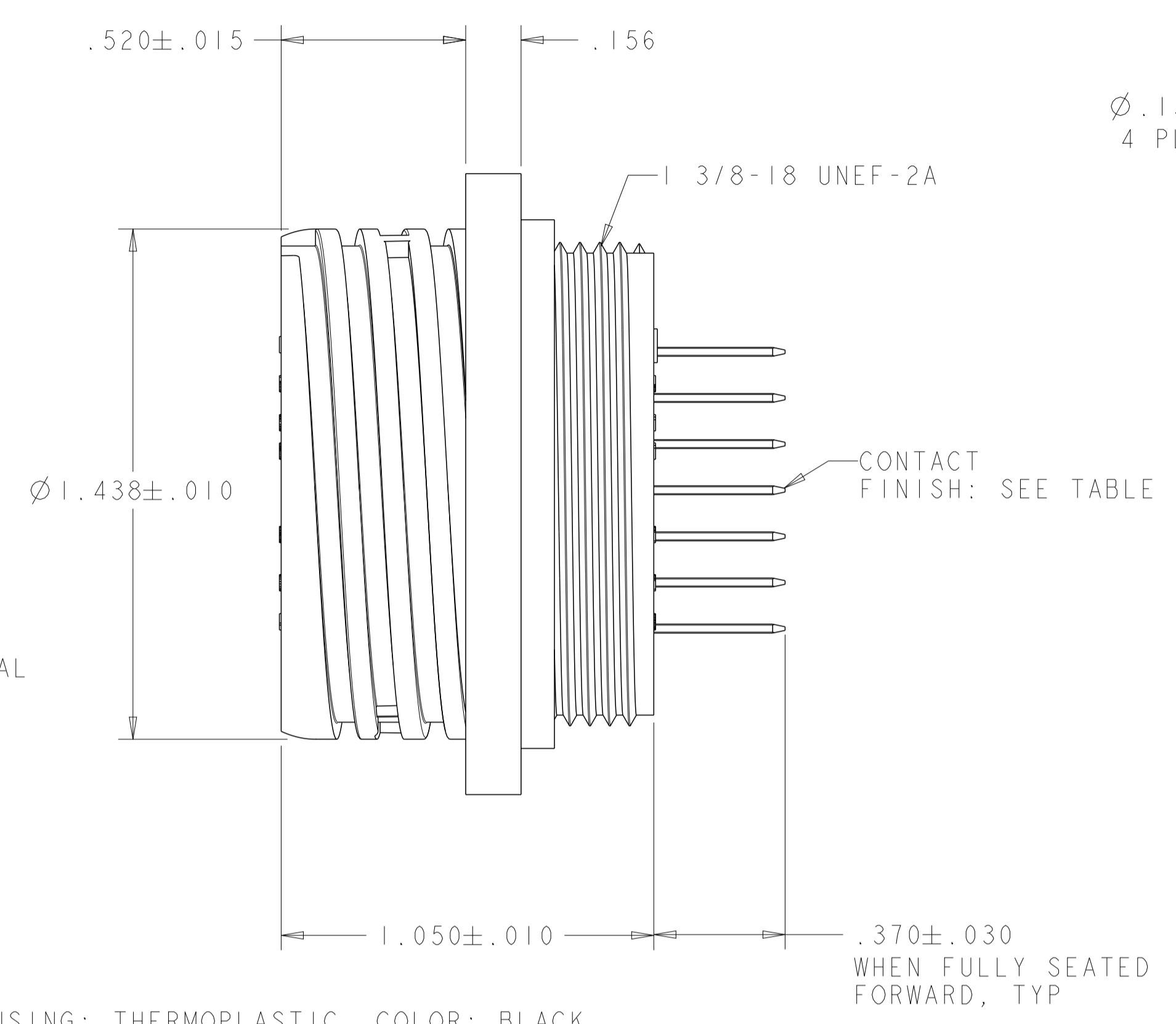
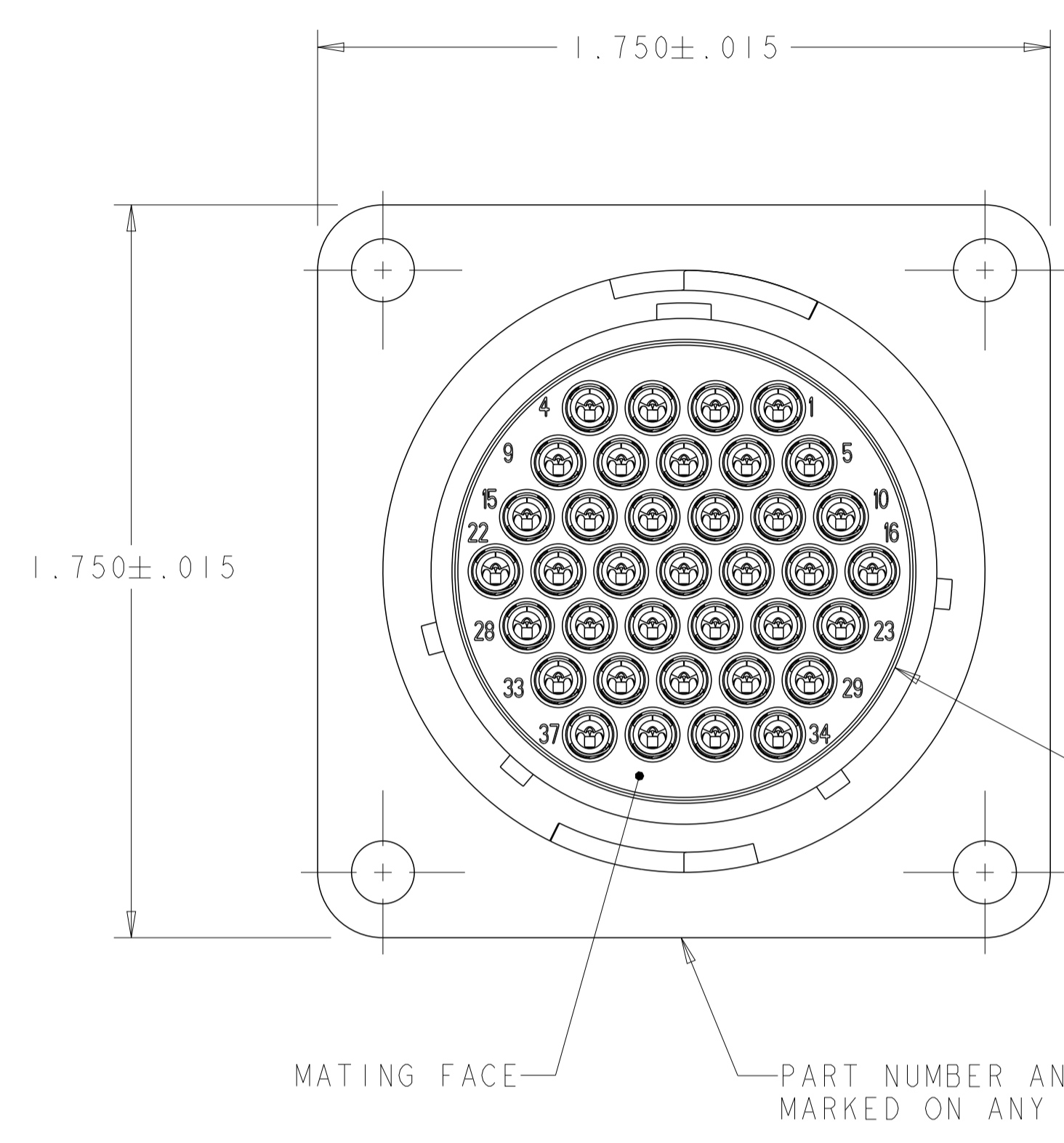
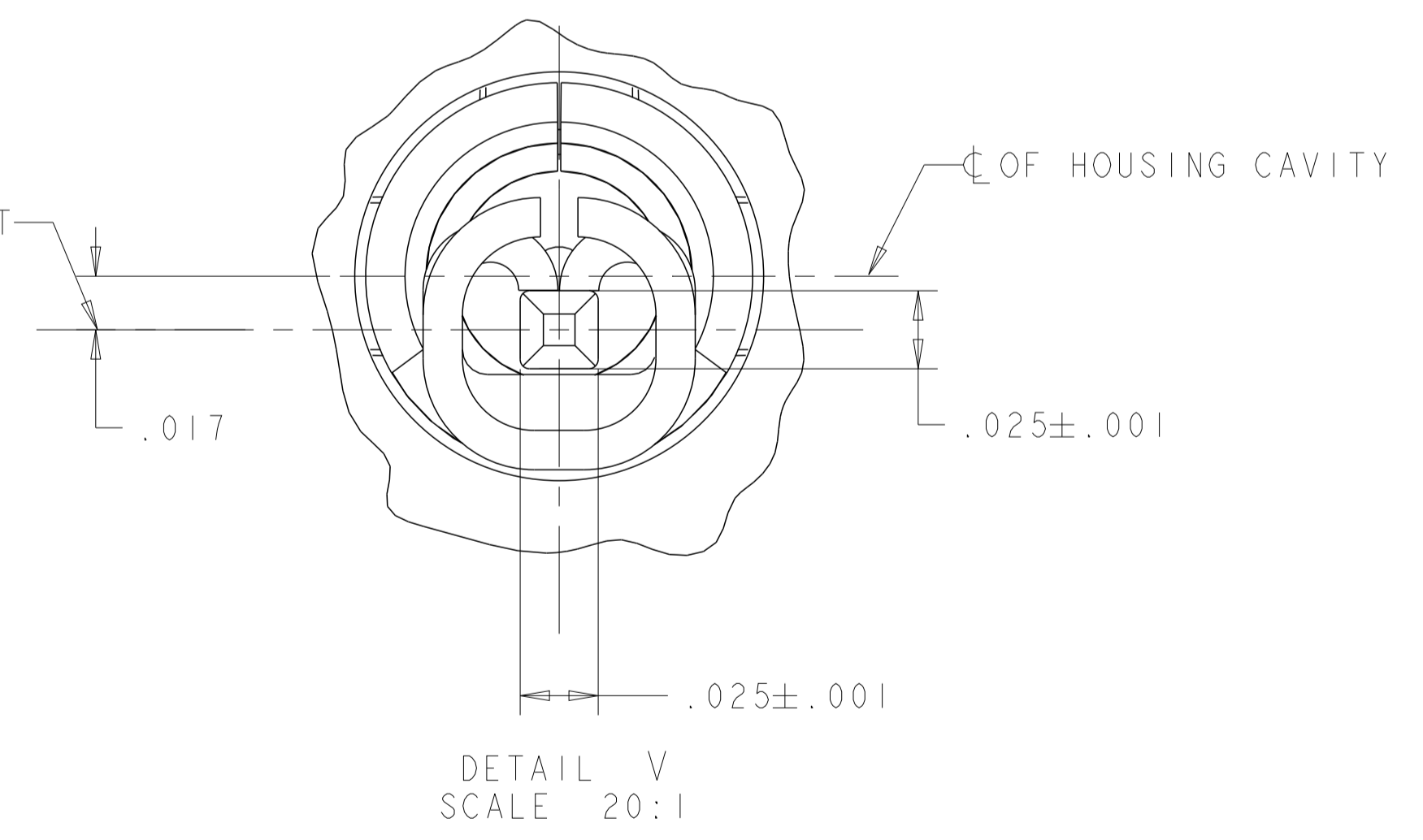
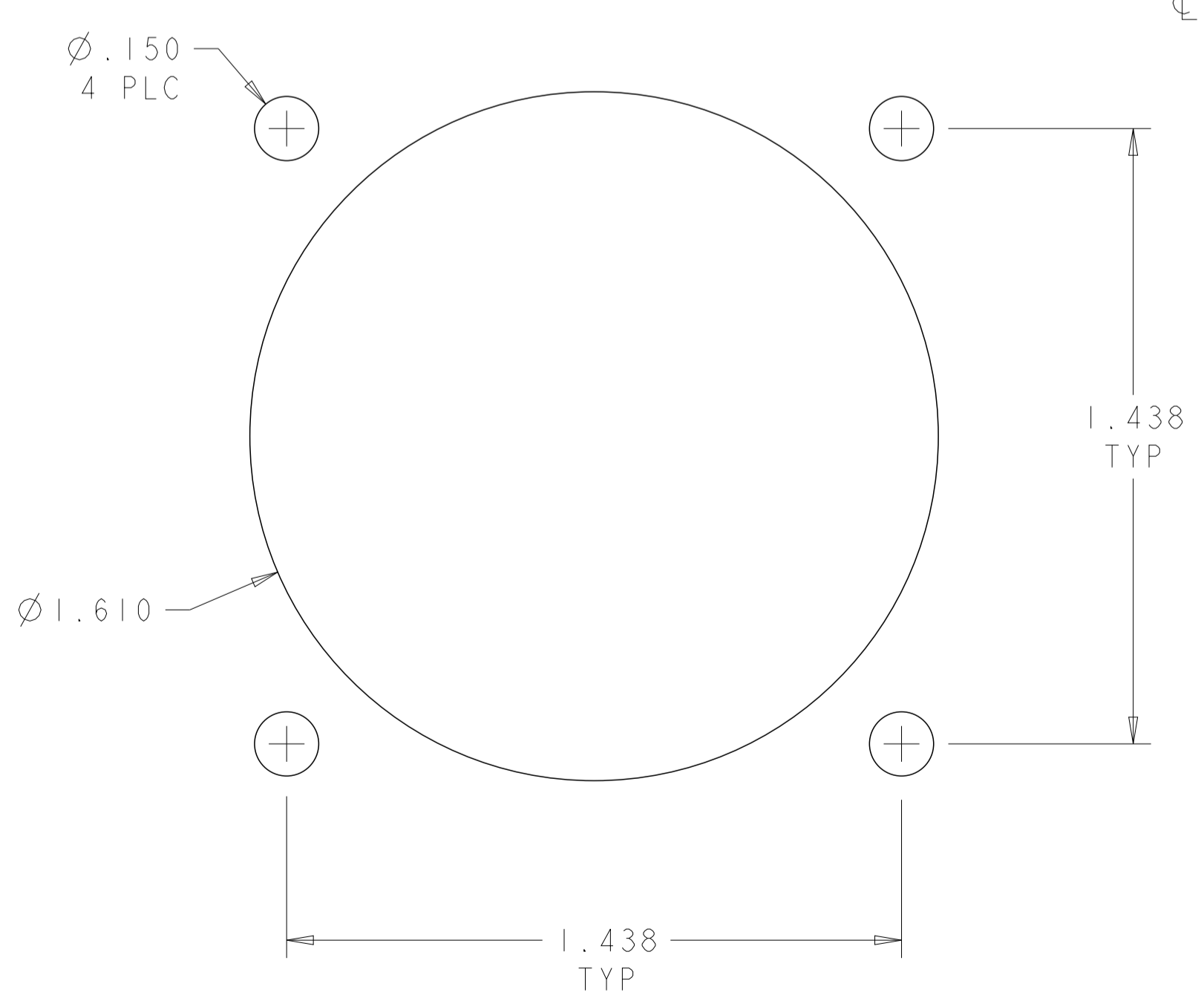
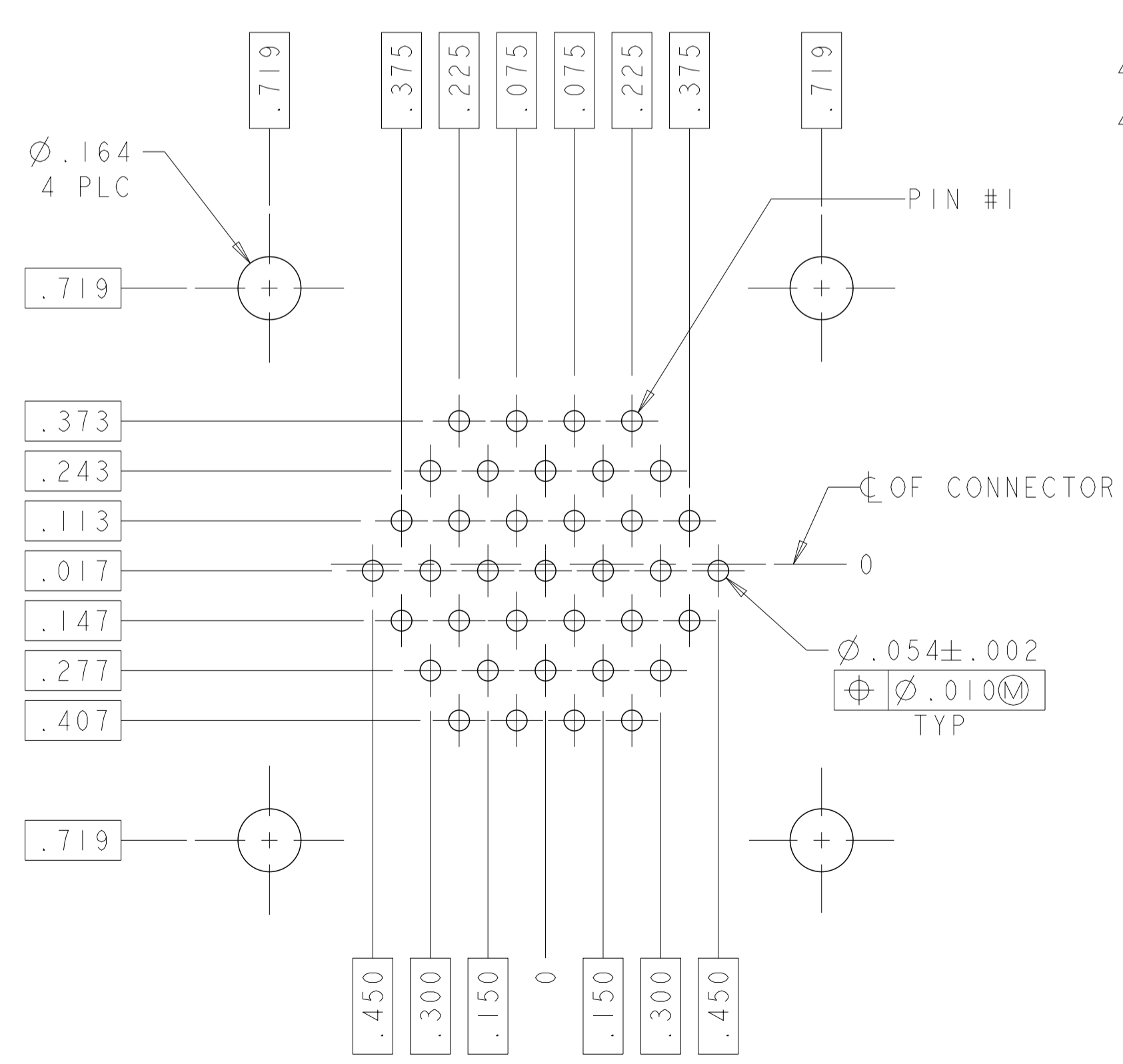

RECOMMENDED PC BOARD LAYOUT

RECOMMENDED PANEL CUTOUT
 .125 MAX PANEL THICKNESS

5	OBSOLETE	YES	1-10, 13-29, 29-37	3	+ 796125 3
	OBSOLETE	YES	1-10, 13-29, 29-37	3	+ 796125 +
5	OBSOLETE	YES	1-10, 13-29, 29-37	2	- 796125 3
	OBSOLETE	YES	1-10, 13-29, 29-37	2	- 796125 1
	PERIPHERAL SEAL		SELECT LOAD IN POSITIONS	CONTACT FINISH	PART NUMBER

THIS DRAWING IS A CONTROLLED DOCUMENT. DWG: S.WELDON 22MAY2003
 CHK: S.HEADER 22MAY2003
 APVD: S.HEADER 22MAY2003

DIMENSIONS: INCHES
 TOLERANCES UNLESS OTHERWISE SPECIFIED:
 0 PLC ±.0
 1 PLC ±.00
 2 PLC ±.00
 3 PLC ±.010
 4 PLC ±.0000
 ANGLES ±.0000

MATERIAL: FINISH: WEIGHT: CUSTOMER DRAWING

NAME: RECEPTACLE ASSEMBLY, POSTED, REVERSE SEX, SERIES 1, 23-37, CPC
 APPLICATION SPEC: 108-10024
 APPLICATION SPEC: 114-10004

SIZE: A1
 CAGE CODE: 100779
 DRAWING NO: 796125
 SHEET 1 OF 1
 REV: G1

SCALE: 3:1

TE Connectivity