



ANATECH ELECTRONICS INC
RF & Microwave Filters & Products

1542-1643 MHz Ceramic Duplexer

Part Number: AM1542-1643D1034



<u>Characteristics</u>	<u>Band 1</u>	<u>Band 2</u>
Passband:	1525-1559 MHz	1626.5-1660.6 MHz
Bandwidth:	34 MHz	34.1 MHz
Passband Return Loss:	15 dB	15 dB
Passband Insertion Loss:	1.85 dB	2.1 dB
Passband Ripple:	0.9 dB	0.9 dB
Input / Output Impedance:	50 Ohms	50 Ohms
Isolation:	60 dB	55 dB
Power Handling:	3 W max	3 W max

<u>Mechanical</u>	
Mounting Method:	SMT
Dimensions:	24 x 8 x 4.6 mm

<u>Environmental</u>	
Operating Temperature:	-40 to +70 deg.C
Storage Temperature:	-50 to +90 deg.C

This product is RoHs compliant.

Outline Drawing:

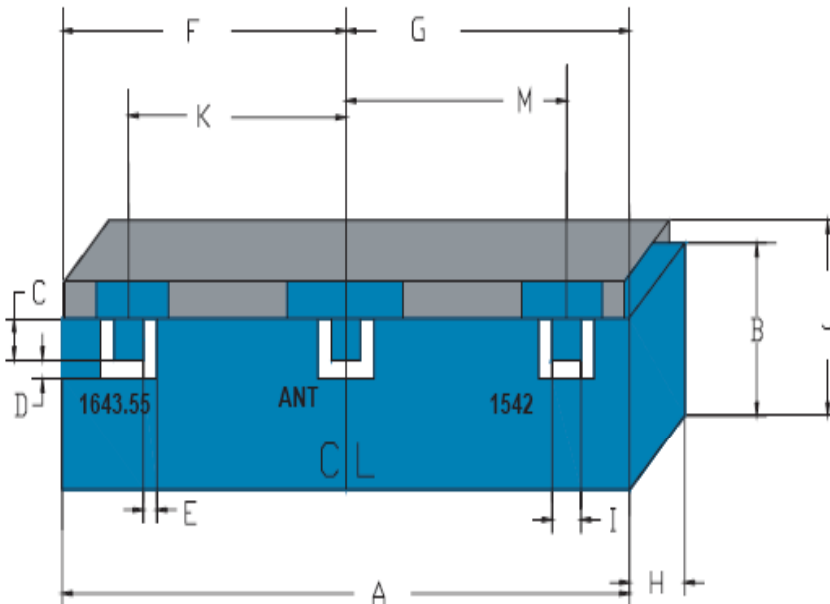

Dim	Nominal (mm)	Tolerance (mm) +/- or max
A	24.00	max
B	7.00	max
C	1.02	0.13
D	1.02	0.13
E	1.02	0.13
F	11.87	0.13
G	11.87	0.13
H	4.60	max
I	1.02	0.13
J	8.00	max
K	9.90	0.13
M	9.90	0.13



ANATECH ELECTRONICS INC
RF & Microwave Filters & Products

1542-1643 MHz Ceramic Duplexer

Part Number: AM1542-1643D1034



Response Plot:

