

# WORLD-BEAM® QS18 Clear Object Detection

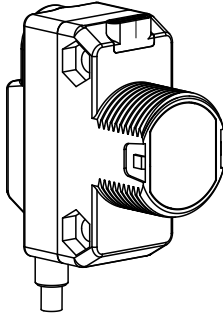

## Datasheet

Cost Effective Coaxial Optics Clear Object Sensor



- Reliably detects clear, translucent, or opaque objects — including PET, glass containers, and transparent films
- Coaxial optics enable reliable detection of targets to the face of the sensor with no dead zone
- Simple setup and adjustment with a single-turn sensitivity adjuster
- Signal strength indicator aids in adjusting sensor sensitivity and monitoring performance
- Fast response speed with low jitter for high speed bottling and packaging applications
- Bright, visible red light spot for easy alignment
- Convenient mounting options available for 18 mm barrel or side mount
- Bright indicator LEDs show operating status from 360°
- IP67 rated ABS housing
- Dedicated PNP or NPN output depending on model



### WARNING: Not To Be Used for Personnel Protection

Never use this device as a sensing device for personnel protection. Doing so could lead to serious injury or death. This device does not include the self-checking redundant circuitry necessary to allow its use in personnel safety applications. A sensor failure or malfunction can cause either an energized or de-energized sensor output condition.

## Models

Models	Mode	Range	Output	Connector <sup>1</sup>
QS18VN6XLP		0 to 2.0 m (0 to 6.5 ft) on BRT-60X40C	NPN	2 m cable (6.5 ft)
QS18VP6XLP		0 to 2.5 m (0 to 8.1 ft) on BRT-51X51BM	PNP	
		0 to 3.0 m (0 to 9.8 ft) on BRT-92X92C		

<sup>1</sup>

- To order the 9 m (30 ft) cable model, add the suffix "W/30" to the cabled model number. For example, QS18VN6XLP W/30.
- To order the 4-pin M12/Euro-style integral quick disconnect model, add the suffix "Q8" to the model number. For example, QS18VN6XLPQ8.
- To order the 150 mm (6 in) PVC cable model with a 4-pin M12/Euro-style quick disconnect, add the suffix "Q5" to the model number. For example, QS18VN6XLPQ5.
- To order the 4-pin M8/Pico-style integral quick disconnect model, add the suffix "Q7" to the model number. For example, QS18VN6XLPQ7.
- To order the 150 mm (6 in) PVC cable model with a 4-pin M8/Pico-style quick disconnect, add the suffix "Q" to the model number. For example, QS18VN6XLPQ.
- Models with a quick disconnect require a mating cordset.



## Overview

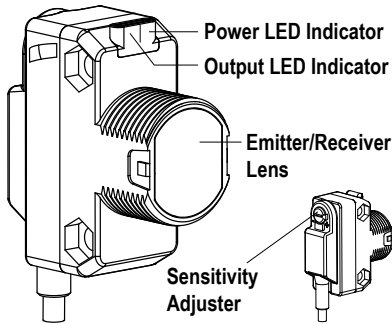

The Banner QS18 sensor is a high performance clear object detection sensor. The polarized coaxial optical design ensures reliable detection of transparent, translucent, and opaque targets at any distance between the sensor and the reflector. Low contrast sensing applications include PET bottles, glass containers, and transparent films. The sensor can also be used to detect optical surfaces such as: LCD panels with built in polarizing films, solar panels, and semiconductor wafers.

Indicators (Two LEDs: One Green, One Amber)		
Sensor Condition	Green LED	Amber LED
Output OFF (black wire)	ON	OFF
Output ON (black wire)	ON	ON
Notification — Signal strength is near the switch point and indicates a marginal sensing condition	Flashing at 5 Hz	Can be ON or OFF
Power ON	ON	—

## Installing and Mounting the Sensor for Low Contrast Applications

Reliable transparent object detection depends on the sensor always detecting the object as "dark state" and the reflector as the "light state". Using a recommended reflector, and proper orientation of the sensor to the reflector, is key to good clear object detection. Optimize the reliable detection of transparent and clear objects by applying the following steps when mounting the sensor and selecting a retroreflective target.

1. If a bracket is needed, mount the sensor onto the bracket.
2. Mount the sensor (or the sensor and the bracket) to the equipment at the desired location. Do not tighten at this time.
3. Align the sensor's light spot to the middle of the retroreflector.
4. Mount the retroreflector perpendicular to the sensor optical axis ( $\pm 5^\circ$ ).
5. Tighten the screws to secure the sensor (or the sensor and the bracket) to the aligned position.

### Mounting Considerations for Opaque Objects with Mirror Like Surfaces

To minimize the potential for reflections from mirror like objects affecting the sensor, it is best to side mount the sensor.

## Wiring Diagrams

NPN Models

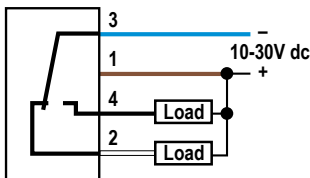

PNP Models

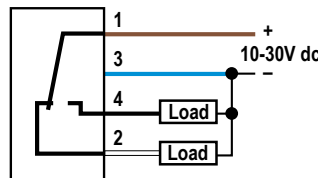

Key

1. Brown
2. White
3. Blue
4. Black

## Sensor Sensitivity Adjustment

After the sensor and retroreflector have been properly installed, the sensor is ready to be adjusted to ensure detection of the desired object. Sensor sensitivity is adjusted with the single turn adjuster.

### Sensor Sensitivity Adjustment for Transparent Object Detection

To adjust the sensor sensitivity to detect transparent objects, follow these steps:

1. Ensure there is nothing obstructing the optical path between the sensor and retroreflector.
2. Turn the sensitivity adjuster counterclockwise to the adjuster stop position.
3. Slowly rotate the sensitivity adjuster clockwise until the Green LED starts flashing and the Amber LED turns off.
4. Continue to turn the sensitivity adjuster clockwise until the Green LED stops flashing.
5. At this point the sensor is set to detect low contrast glass and plastic containers.
6. Check to make sure that the sensor can now reliably detect the transparent target.

This level of adjustment should work for most transparent object detection applications. For more demanding applications, the sensor can be adjusted closer to the switch point.

## Sensor Sensitivity Adjustment for Opaque Object Detection

To adjust the sensor sensitivity to detect objects that are completely opaque, follow these steps:

1. Ensure there is nothing obstructing the optical path between the sensor and retroreflector.
2. Turn the sensitivity adjuster clockwise to the adjuster stop position. The amber LED should be off.
3. Place the opaque object between the sensor and the reflector.
4. Turn the sensitivity adjuster counterclockwise until the amber LED turns on and the green LED is on solid.
5. Check to make sure the sensor can reliably detect the opaque object.

If the sensor cannot reliably detect the object, use the procedure specified above for transparent object detection.

## Specifications

**Supply Voltage**  
10 V to 30 V dc (10% maximum ripple) within specified limits

**Supply Current (Exclusive of Load Current)**  
< 25 mA

**Repeatability**  
100 µs

**Supply Protection Circuitry**  
Protected against reverse polarity and transient voltages

**Output Protection Circuitry**  
Protected against false pulse on power-up and continuous overload or short-circuit

**Output Configuration**  
Current sourcing (PNP) or current sinking (NPN), depending on model  
Rating: 100 mA maximum  
OFF-State leakage current: < 50 µA at 30 V  
ON-state saturation voltage: < 1.5 V at 10 mA; < 3 V 100 mA

**Connections**  
PVC-jacketed 4-conductor 2 m (6.5 ft) or 9 m (30 ft) unterminated cable, or 4-pin Euro-style or 4-pin Pico-style quick-disconnect, either integral or 150 mm (6 in) cabled, are available. Quick disconnect cordsets are ordered separately.

**Operating Conditions**  
Temperature: -40 °C to +70 °C (-40 °F to +158 °F)  
Humidity: 95% at +50 °C maximum relative humidity (non-condensing)

**Environmental**  
IEC IP67; NEMA 6

**Adjustments**  
Single-turn sensitivity adjustment

**Application Notes**  
Reflectors with micro-prism geometry, such as the BRT-51X51BM, are recommended for demanding transparent object detection applications. Retroreflective tape is not recommended for transparent object detection applications.

**Certifications**

**Output Response Time**  
Note: Momentary delay on power-up; output does not conduct during this time  
400 µs ON/OFF

**Emitter LED**  
Visible red, 625 nm

**Indicators**  
Two LEDs (1 green, 1 amber)  
Green solid: Indicates power is applied and the sensor is ready  
Green flashing: Indicates the sensor is operating near the switch point  
Amber solid: Indicates output conducting

**Mounting Torque**  
Barrel mount: 18 mm mounting nut, 20 lbf-in (2.3 N-m)  
Side mount: Two M3 screws, 5 lbf-in (0.6 N-m)

**Construction**  
ABS housing, PMMA window

**Required Overcurrent Protection**



**WARNING:** Electrical connections must be made by qualified personnel in accordance with local and national electrical codes and regulations.

Overcurrent protection is required to be provided by end product application per the supplied table. Overcurrent protection may be provided with external fusing or via Current Limiting, Class 2 Power Supply. Supply wiring leads < 24 AWG shall not be spliced. For additional product support, go to [www.bannerengineering.com](http://www.bannerengineering.com).

Supply Wiring (AWG)	Required Overcurrent Protection (Amps)
20	5.0
22	3.0
24	2.0
26	1.0
28	0.8
30	0.5



### Dimensions

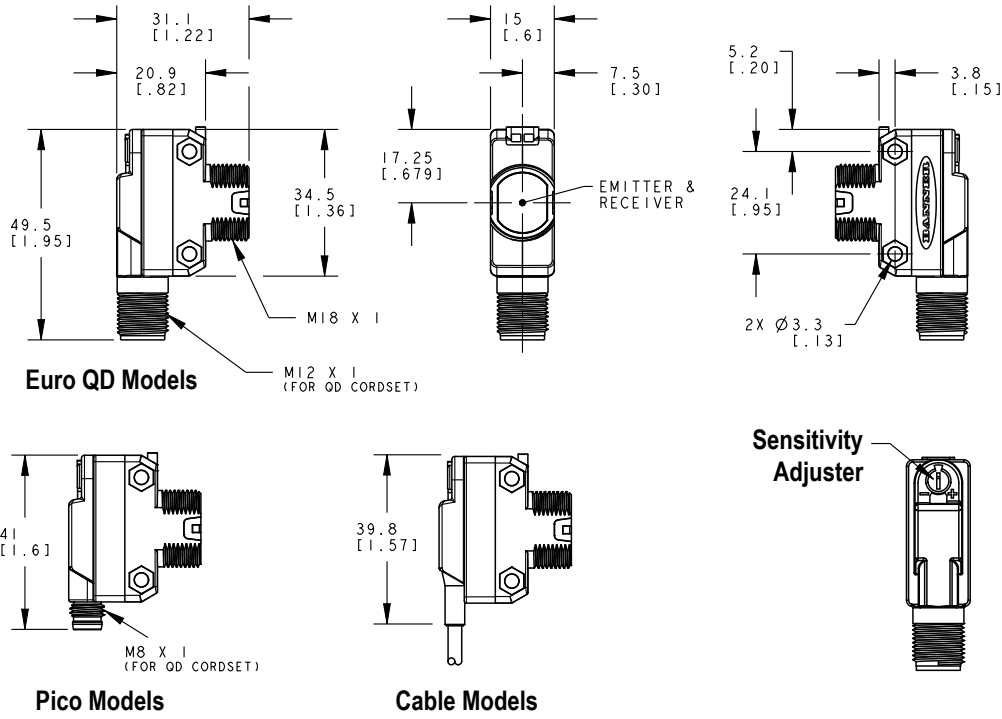

### Performance Curves

Spot Size vs. Distance

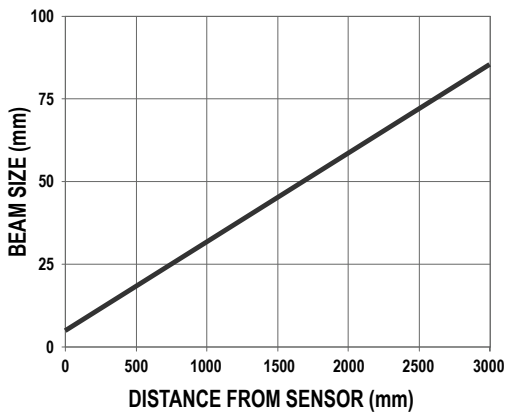

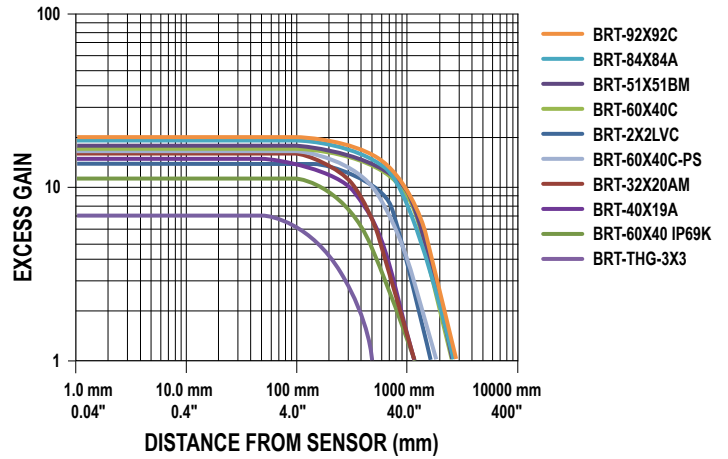

Excess Gain

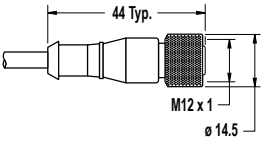
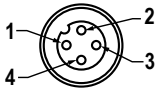
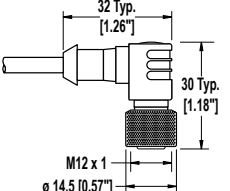

## Accessories

### Cordsets

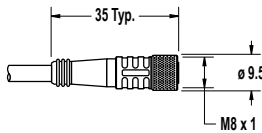
4-Pin Threaded M12/ Euro-Style Cordsets				
Model	Length	Style	Dimensions	Pinout (Female)
MQDC-406	1.83 m (6 ft)	Straight		 <p>1 = Brown 2 = White 3 = Blue 4 = Black</p>
MQDC-415	4.57 m (15 ft)			
MQDC-430	9.14 m (30 ft)			
MQDC-450	15.2 m (50 ft)			
MQDC-406RA	1.83 m (6 ft)	Right-Angle		
MQDC-415RA	4.57 m (15 ft)			
MQDC-430RA	9.14 m (30 ft)			
MQDC-450RA	15.2 m (50 ft)			

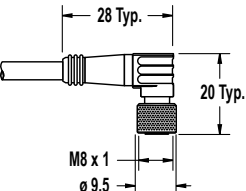
4-Pin Threaded M8/ Pico-Style Cordsets				
Model	Length	Style	Dimensions	Pinout (Female)
PKG4M-2	2 m (6.56 ft)	Straight		 <p>1 = Brown 2 = White 3 = Blue 4 = Black</p>
PKG4M-5	5 m (16.4 ft)			
PKG4M-9	9 m (29.5 ft)			
PKW4M-2	2 m (6.56 ft)	Right Angle		
PKW4M-5	5 m (16.4 ft)			
PKW4M-9	9 m (29.5 ft)			

### Retroreflectors

#### BRT-51X51BM

- Square, acrylic target
- Reflectivity Factor: 1.5
- Temperature: -20 °C to +50 °C (-4 °F to +122 °F)
- Micro-prism geometry
- Optional brackets are available
- Approximate size: 51 mm x 51 mm

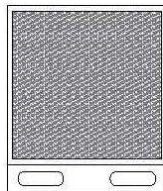

#### BRT-60X40C

- Rectangular, acrylic target
- Reflectivity Factor: 1.4
- Temperature: -20 °C to +60 °C (-4 °F to +140 °F)
- Optional brackets are available
- Approximate size: 40 mm x 60 mm

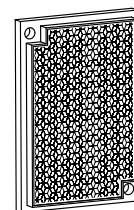

**BRT-92X92C**

- Square, acrylic target
- Reflectivity Factor: 3.0
- Temperature: -20 °C to +60 °C (-4 °F to +140 °F)
- Optional brackets are available
- Approximate size: 92 mm x 92 mm



**BRT-40X19A**

- Rectangular, acrylic target
- Reflectivity Factor: 1.3
- Temperature: -20 °C to +60 °C (-4 °F to +140 °F)
- Approximate size: 19 mm x 60 mm overall; 19 mm x 40 mm reflector

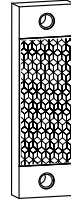

**BRT-60X40IP69K**

- Rectangular, acrylic target (color is amber)
- Reflectivity Factor: 0.7
- Temperature: -20 °C to +140 °C (-4 °F to +284 °F)
- Chemically resistant
- IP69K washdown rated
- Optional brackets are available
- Approximate size: 40 mm x 60 mm

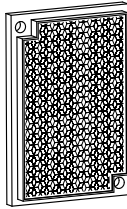

**BRT-60X40C-PS**

- Rectangular, polystyrene target
- Reflectivity Factor: 1.1
- Temperature: -20 °C to +60 °C (-4 °F to +140 °F)
- Optional brackets are available
- Chemically compatible with hydrogen peroxide
- Yellow back
- Approximate size: 40 mm x 60 mm

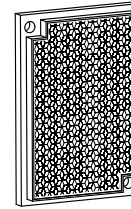

2 in retroreflective tape, 2.5 m (100 in)

Model	Reflectivity Factor	Maximum Temperature	Size
BRT-THG-2-100	0.7	+60 °C (+140 °F)	50 mm (2 in) wide, 2.5 m (100 in) long

**Brackets**

**SMB18A**

- Right-angle mounting bracket with a curved slot for versatile orientation
- 12-ga. stainless steel
- 18 mm sensor mounting hole
- Clearance for M4 (#8) hardware

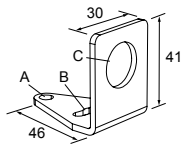

Hole center spacing: A to B = 24.2  
Hole size: A =  $\varnothing$  4.6, B = 17.0 x 4.6, C =  $\varnothing$  18.5

**SMBQS18Y**

- Die-cast bracket for 18 mm holes
- Includes metal hex nut and lock washer
- Allows  $\pm$  8° for cabled sensors

Hole size: A =  $\varnothing$  15.3

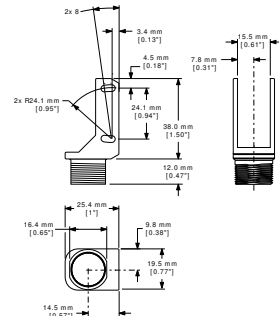

SMBQ4X..

- Swivel bracket with tilt and pan movement for precision adjustment
- Easy sensor mounting to extruded rail T-slots
- Metric and inch size bolts available
- Side mounting of some sensors with the 3 mm screws included with the sensor

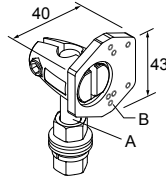

B = 7 x M3 x 0.5

Model	Bolt Thread (A)
SMBQ4XFAM10	M10 - 1.5 x 50
SMBQ4XFAM12	n/a; no bolt included. Mounts directly to 12 mm (½ in) rods

SMB18AFA..

- Protective, swivel bracket with tilt and pan movement for precision adjustment
- Easy sensor mounting to extruded rail T-slots
- Metric and inch size bolts available
- Mounting hole for 18 mm sensors

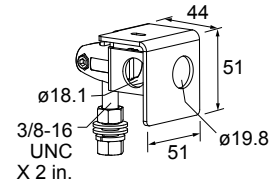

Hole size: B = ø 18.1

Model	Bolt Thread (A)
SMB18AFA	3/8 - 16 x 2 in
SMB18AFAM10	M10 - 1.5 x 50

SMB312S

- Stainless steel 2-axis, side-mount bracket

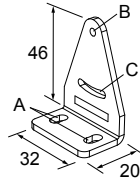

A = 4.3 x 7.5, B = diam. 3, C = 3 x 15.3

## Banner Engineering Corp. Limited Warranty

Banner Engineering Corp. warrants its products to be free from defects in material and workmanship for one year following the date of shipment. Banner Engineering Corp. will repair or replace, free of charge, any product of its manufacture which, at the time it is returned to the factory, is found to have been defective during the warranty period. This warranty does not cover damage or liability for misuse, abuse, or the improper application or installation of the Banner product.

THIS LIMITED WARRANTY IS EXCLUSIVE AND IN LIEU OF ALL OTHER WARRANTIES WHETHER EXPRESS OR IMPLIED (INCLUDING, WITHOUT LIMITATION, ANY WARRANTY OF MERCHANTABILITY OR FITNESS FOR A PARTICULAR PURPOSE), AND WHETHER ARISING UNDER COURSE OF PERFORMANCE, COURSE OF DEALING OR TRADE USAGE.

This Warranty is exclusive and limited to repair or, at the discretion of Banner Engineering Corp., replacement. IN NO EVENT SHALL BANNER ENGINEERING CORP. BE LIABLE TO BUYER OR ANY OTHER PERSON OR ENTITY FOR ANY EXTRA COSTS, EXPENSES, LOSSES, LOSS OF PROFITS, OR ANY INCIDENTAL, CONSEQUENTIAL OR SPECIAL DAMAGES RESULTING FROM ANY PRODUCT DEFECT OR FROM THE USE OR INABILITY TO USE THE PRODUCT, WHETHER ARISING IN CONTRACT OR WARRANTY, STATUTE, TORT, STRICT LIABILITY, NEGLIGENCE, OR OTHERWISE.

Banner Engineering Corp. reserves the right to change, modify or improve the design of the product without assuming any obligations or liabilities relating to any product previously manufactured by Banner Engineering Corp. Any misuse, abuse, or improper application or installation of this product or use of the product for personal protection applications when the product is identified as not intended for such purposes will void the product warranty. Any modifications to this product without prior express approval by Banner Engineering Corp will void the product warranties. All specifications published in this document are subject to change; Banner reserves the right to modify product specifications or update documentation at any time. Specifications and product information in English supersede that which is provided in any other language. For the most recent version of any documentation, refer to: [www.bannerengineering.com](http://www.bannerengineering.com).