

PRODUCT NUMBER	ZONE "A" PLATING
90306-001	100μ/2.54μ MIN. SnPb
90306-001LF	100μ/2.54μ MIN. Sn

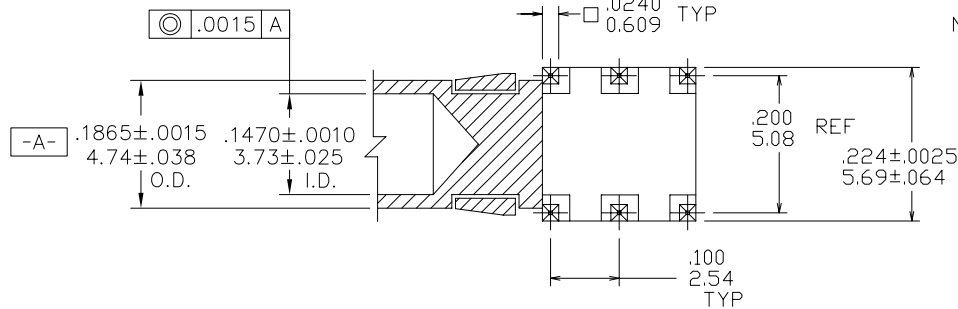
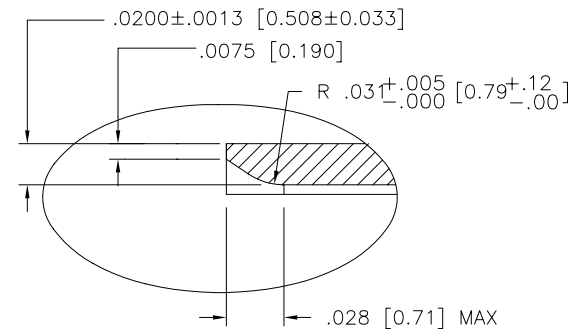
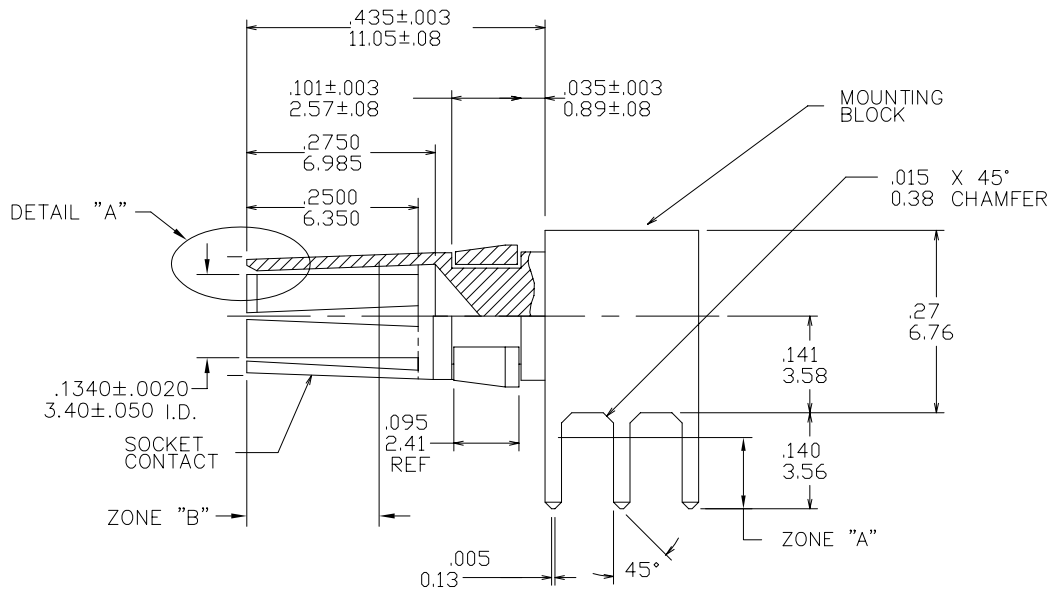

NOTES:

- MATERIAL:  
 SOCKET CONTACT: BeCu  
 MOUNTING BLOCK: BRASS  
 SNAP RING: PHOS. BRONZE (ALLOY 510)
- PLATING:  
 ZONE A: SEE TABLE  
 ZONE B: 30u"/.76u MIN Au OVER  
 UNDERPLATE: 50u"/1.27u MIN Ni
- HEAT TREATING: 625°F f/ 2-1/2 HRS.
- NO BURRS ALLOWED IN SOCKET INTERIOR.
- SURFACE FINISH IN CONTACT AREA NOT TO EXCEED 25rms.

mat'l. code		surface		tolerance		projection		product family	
NOTE 1		ISO 1302 ✓		ISO 406		ISO 1101		HPC	
tolerances unless otherwise specified		angles		linear		INCH/MM		title	
G v04394 MDF 2/16/94		.xx±.01/.3		.xxx±.005/.13		scale 1:1		CLOSED PWR SOCKET	
H v40764 PDP 4/4/94		0'±2'		.xxxx±.0020/.051		FCI		dwg no 90306 sheet 1 of 1 size A3	
J v60760 MDF 5/20/96		M.FETROW 6/12/91		S.CLARK 6/12/91		S.CLARK 6/12/91		type Product Customer Drawing	
K v00720 LSS 4/11/00		S.CLARK 6/12/91		S.CLARK 6/12/91		S.CLARK 6/12/91			
L v05-0743 DAI 10/18/05		enr		appd					
M v06-0283 MHT 7/27/06		chr							
sheet index	revision	M							
	sheet	1							