



## DC503A DEMO BOARD QUICK START GUIDE

### *Description:*

The DC503A demo circuit board is intended to demonstrate the capabilities of the LT5512 downconverting mixer IC for cable infrastructure applications.

The LT<sup>®</sup>5512 (Figure 1) is a broadband high signal level mixer IC optimized for high linearity downconverter applications including cable and wireless infrastructure. The IC includes a differential LO buffer driving a double-balanced mixer. An integrated RF amplifier improves LO-RF isolation and eliminates the need for precision external bias resistors.

The LT5512 is a high-linearity alternative to passive diode mixers. Unlike passive mixers, which have conversion loss and require high LO drive level, the LT5512 delivers conversion gain and requires significantly lower LO drive levels.

The DC503A demo board downconverts 1230MHz RF input to 270-870MHz IF output. The LO is injected from the high-side between 1500MHz and 2100MHz.

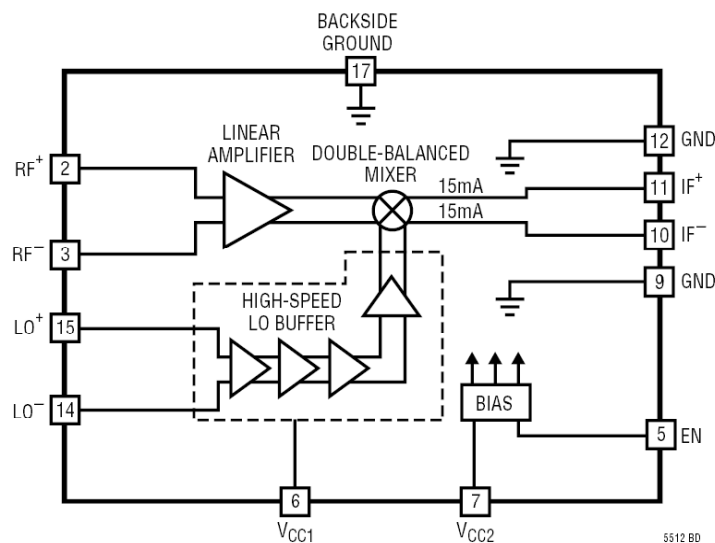

**Figure 1. LT5512 IC Block Diagram**

## LT5512 Downconverting Mixer Single-Tone Measurements for 1230 MHz CATV Band.

1. Connect all test equipment as shown in Figure 2.
2. Set the Power Supply output voltage to 5V, and set the current limit to 100mA.
3. Connect TP1 (EN) to the 5V power supply. Mixer is in ENABLE mode.
4. Set the Signal Generator #1 to provide an 1800MHz, -10dBm, CW signal to the demo board LOin port.
5. Set the Signal Generator #2 to provide a 1230MHz, -10dBm, CW signal to the demo board RFIn port.
6. Set the Spectrum Analyzer's center frequency to 570MHz. Perform mixer conversion gain, and 1dB compression measurements.
7. Set the Spectrum Analyzer's center frequency to 1800MHz. Perform mixer LO to IF leakage measurement.

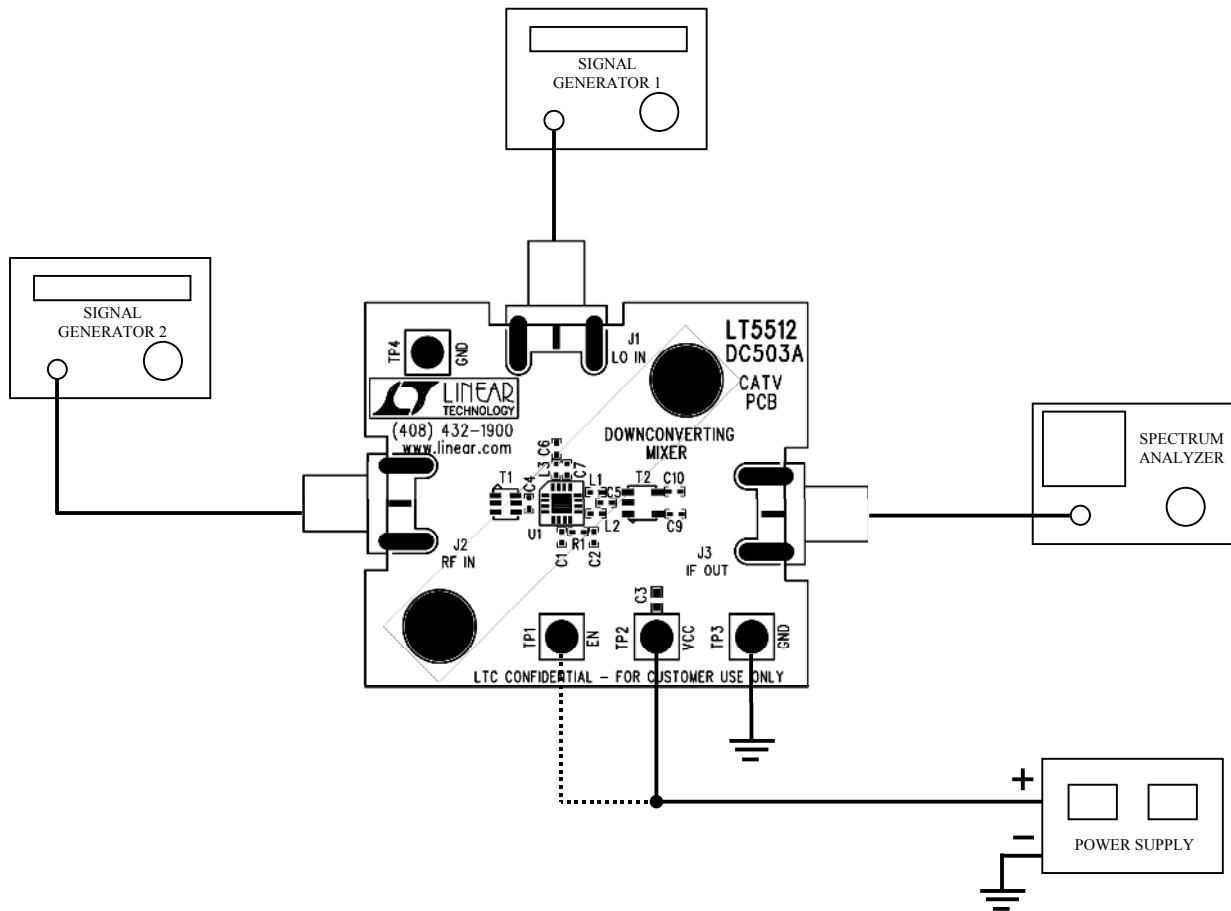

Figure 2. Test Set-Up for Mixer Single-Tone Measurements.

## LT5512 Downconverting Mixer Two-Tone Measurements for 1230MHz CATV Band.

1. Connect all test equipment as shown in Figure 3.  
 Note: 1). A high quality combiner that provides 50-ohm termination on all ports and has good port-to-port isolation should be used.  
 2). The two 3dB attenuators on the inputs of the combiner are used to further improve source isolation.
2. Set the Power Supply output voltage to 5V, and set the current limit to 100mA.
3. Connect TP1 (EN) to the 5V power supply. Mixer is in ENABLE mode.
4. Set the Signal Generator #1 to provide a 1800MHz, -10dBm, CW signal to the demo board LOin port.
5. Set the Signal Generator #2 and #3 to provide two -10dBm CW signals to the demo board RFin port—one at 1229.9MHz, and the other at 1230.1MHz.
6. Set the Spectrum Analyzer's center frequency to 570MHz. Perform input 3<sup>rd</sup> order distortion measurement. (IIP3 =  $P_1 + (P_1 - P_3) / 2 - G_c$ , where  $P_1$  is the lowest power level of the two desired output tones at either 569.9MHz or 570.1MHz,  $P_3$  is the largest 3<sup>rd</sup> order product at either 569.7MHz or 570.3MHz, and  $G_c$  is conversion gain.  $P_1$  and  $P_3$  are in units of dBm, and  $G_c$  is in dB.)

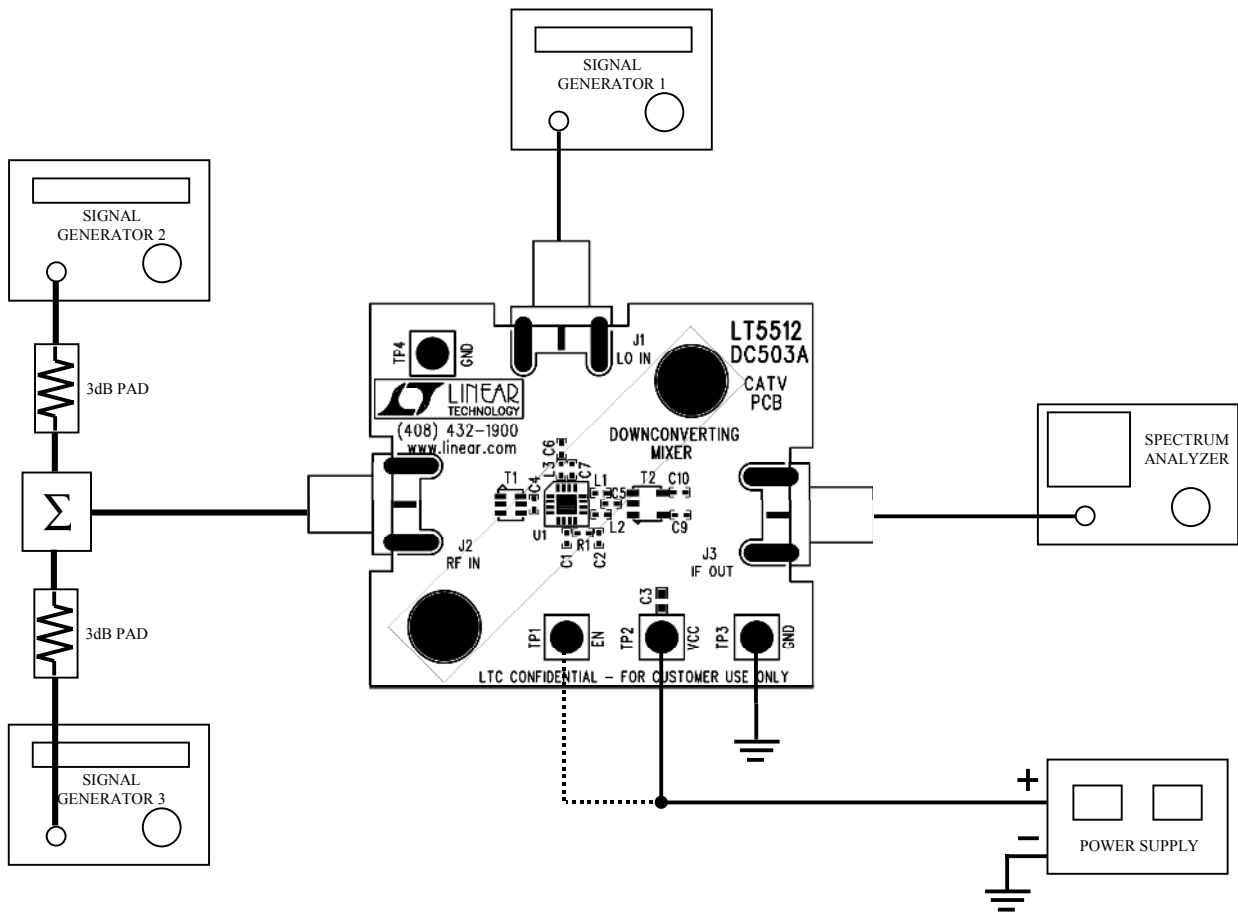
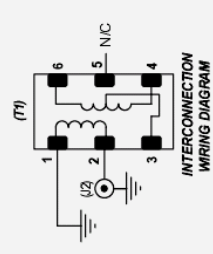
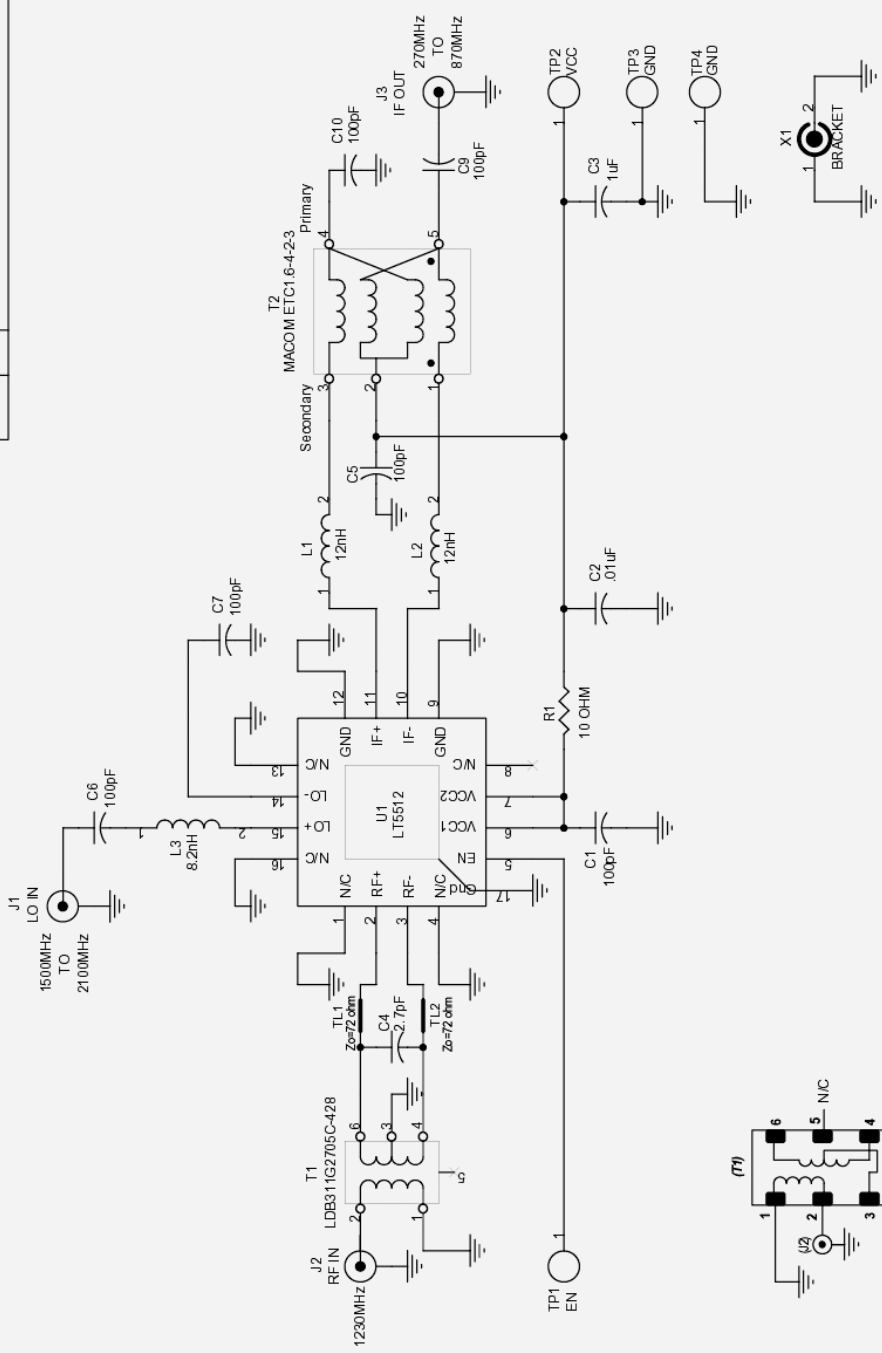

Figure 3. Test Set-Up for Mixer Two-Tone Measurements.

ECO		REVISION HISTORY	
REV	DESCRIPTION	DATE	APPROVED
1	INITIATE	01/23/02	
2	REVISED: DEMO BOARD RELEASE	5/7/02	



UNLESS OTHERWISE SPECIFIED DIMENSIONS ARE IN INCHES TOLERANCE ON ANGLE ... 2 PLACES ... 3 PLACES ... INTERPRET DIM AND TOL PER ASME Y14.5M -1994		CONTRACT NO.	
THIRD ANGLE PROJECTION		APPROVALS	DATE
		DRAWN L. SANTOS	01/23/02
		CHECKED	
		APPROVED	01/23/02
		DESIGNER	
DO NOT SCALE DRAWING		ENGINEER VLAD D.	01/23/02
Tuesday, May 14, 2002		FILENAME503A2.DSN	SHEET 1 OF 1

LINEAR TECHNOLOGY  
1630 McCarthy Blvd  
Milpitas, CA 95035  
Phone: (408) 943-1600  
Fax: (408) 943-6607

SCHEMATIC, DOWNCONVERTING MIXER CATV PCB

DC503A

REV 2

1PC CONFIDENTIAL - For Customer Use Only

Item	Qty	Reference Designator	Part Description	Manufacture / Part No.
1	6	C1,C5,C6,C7,C9,C10	CAP, COG, 100pF, 50V, 5%, 0402	MURATA GRP1555C1H101JD01
2	1	C2	CAP, X7R, .01uF, 16V, 10%, 0402	MURATA GRP155R71C103KA01
3	1	C3	CAP, Y5V, 1uF, 10V, [+80%,-20%], 0603	TAIYO YUDEN LMK107F105ZA
4	1	C4	CAP, COG, 2.7pF, 50V, +/- .25pF, 0402	MURATA GRP1555C1H2R7CZ01
5	1	R1	RES, CHIP, 10 OHM, 1%, 0402	AAC CR05-10R0FM
6	2	L1,L2	IND, 12nH, 5%, 0402	TOKO LL1005-FH12NJ
7	1	L3	IND, 6.8nH, 10%, 0402	TOKO LL1005-FH8N2K
8	1	T1	XFMR, 1:1, HYBRID, 1275MHz +/-139MHz	MURATA LDB311G2705C-428
9	1	T2	XFMR, 4:1, RF WIDEBAND, 500-2500MHz	M/A-COM ETC1.6-4-2-3
10	1	U1	IC, LT5512EUF, 4X4mm QFN	LINEAR LTC5512EUF
11	3	J1,J2,J3	CONN, SMA, 50-OHM EDGE-LAUNCH	E.F. JOHNSON 142-0701-851
13	3	TP1,TP2,TP3	TESTPOINT, TURRET, .090	MILL-MAX 2501-2
12	1		PCB, DC503A	DEMO BOARD DC503A

APPROVED VENDOR LIST

VENDOR	PHONE NUMBER	PART TYPE	WEBSITE ADDRESS
AAC (was TAD)	(800) 508-1521	CHIP RESISTORS	
AAC (was TAD)	(714) 255-9186		
AAVID	(714) 556-2665	HEAT SINKS	
ALLEN BRADLEY	(800) 592-4888	CARBON RESISTORS	
AMP	(717) 564-0100	PC MOUNT BNC	
APEM	(718) 246-1007	SMD TOGGLE/PB SWITCH	
API DELEVAN	(716) 652-3600	INDUCTORS	
AVX	(843) 946-0362	CHIP CAPS	
AVX	(843) 946-0524	CHIP RESISTORS	
AVX	(207) 282-5111	TANTALUM CAPS	
AVX	(843) 946-0323	HIGH VOLTAGE CAPS	
BERG	(800) 237-2374	CONNECTORS	
BH ELECTRONICS	(952) 894-9590	INDUCTORS	
BI TECHNOLOGIES	(714) 447-2656	TRANSFORMERS	
BI TECHNOLOGIES	(714) 447-2345	RES./RES. NETWORKS	
BOURNS	(801) 750-7253	POTENTIOMETERS, SIPS	
CADDOCK ELECTRONICS	(541) 496-0700	HIPO. RES., SIPS, DIPS	
CENTRAL SEMI	(631) 435-1110	SMALL SIGNAL DISCRETES	
CHICAGO MINIAT. LAMP	(201) 489-8989	LEDS	
COILCRAFT	(847) 639-6400	INDUCTORS	
COMM CON	(626) 301-4200	HEADERS, SHUNTS	
CONNEX	(805) 378-6464	BNC CONNECTORS	
COOPER ELECT. TECH.	(561) 752-5000	INDUCTORS	
CORNELL DUBILIER	(508) 996-8561	CAPACITORS	
CTS	(219) 293-7511	RESISTOR ARRAYS	
CUI-STACK	(503) 643-4899	POWER CONNECTORS	
DALE (see Vishay)	(605) 665-1627	INDUCTORS	
DALE (see Vishay)	(605) 665-9301	SENSE RESISTORS	
DATA DISPLAY PRODUCT	(800) 421-6815	LEDS	
DIODES INC.	(805) 446-4800	DIODES	
ELECTRONIC CONCEPTS	(908) 542-7880	400V FILM CAPACITORS	
EPSON	(310) 787-6300	CRYSTALS	
FAIRCHILD	(207) 775-4502	LOGIC	
FAIRCHILD	(408) 822-2126	MOSFETS	
FAIRCHILD	(888) 522-5372	CRG (CUST. RESPONSE)	
FCI	(717) 767-8005	HOT PLUG CONNECTORS	
FUKUSHIMA	(818) 765-8300	MPC RESISTORS	
FUJI	(201) 712-0555	SCHOTTKY DIODES	
GENERAL SEMICONDUCTOR	(516) 847-3000	DIODES	
GOWANDA	(716) 532-2234	INDUCTORS	
GRAYHILL	(708) 354-1040	DIP SWITCHES	
HARRIS	(800) 442-7747	LOGIC	
HEWLETT PACKARD	(800) 235-0312	IR LED	
HITACHI	(408) 433-1990	RF POWER AMPS	

IDT	(408) 727-6116	LOGIC IC
IR	(310) 322-3331	MOSFETS
IRC	(361) 992-7900	SENSE RESISTORS
ITW PAKTRON	(708) 667-3444	CAPACITORS
JOHNSON COMPONENTS	(650) 948-6533	RF CONNECTORS
JOHNSON COMPONENTS	(760) 434-5961	RF CONNECTORS
KEMET	(408) 986-0424	TANTALUM CAPS
KEMET	(864) 963-6300	CRG (CUST. RESPONSE)
KETEMA	(714) 630-0081	SURGE SUPPRESSORS
KEYSTONE	(718) 956-8900	JACKS, TURRETS
LITEON	(408) 241-4588	LEDS, DIODES
LTC	(408) 432-1900	HIGH PERF. I.C.S
MAGNETICS	(800) 245-3984	TOROID CORES ETC.
MARCON	(847) 696-2000	HIGH C/V CAPACITORS
METHODE	(800) 323-6864	ZIF SOCKETS
MF ELECTRONICS	(914) 576-6570	CRYSTAL OSCILLATORS
MICROCHIP	(602) 786-7200	MICROCONTROLLER IC
MICRO PLASTICS	(870) 453-8861	NYLON STANDOFFS
MICRO-SEMI	(617) 926-0404	DIODES
MIDCOM	(605) 886-4385	INDUCTORS
MIDCOM	(800) 643-2661	INDUCTORS
MILL-MAX	(516) 922-6000	TURRETS
MINICIRCUITS	(718) 934-4500	RF TRANSFORMERS
MOTOROLA	(800) 441-2447	LOGIC, REGS
MURATA ELECTRONICS	(770) 436-1300	CAPS., INDUCTORS,
MURATA ELECTRONICS	(800) 831-9172	CRG (CUST. RESPONSE)
MURATA ELECTRONICS	(770) 433-5789	RF DEVICES
NEC/TOKIN	(510) 324-4110	INDUCTORS/HI C/V CAPS
NICHIA	(408) 573-0933	WHITE LEDS
NICHICON	(847) 843-7500	ELECTROLYTIC CAPACITOR
ON SEMICONDUCTOR	(602) 244-6600	DISCRETE DIODES ETC.
ON SHORE	(602) 921-3000	TERMINATORS
PANASONIC	(714) 373-7334	INDUCTORS, POLY CAPS
PANASONIC	(201) 348-5217	LEDS
PANASONIC	(201) 373-7334	SWITCHES
PERICOM	(408) 435-0800	LOGIC IC
PHILIPS	(914) 246-2811	INDUCTORS
PHILIPS	(914) 247-2036	PLANAR INDUCTORS
PHILIPS	(508) 851-2200	DISCRETES, I.C.s
PULSE	(619) 674-8100	INDUCTORS
QT OPTOELECTRONICS	(408) 720-1440	RF SWITCH
RAYCHEM	(800) 227-4856	FUSES
RG ALLEN	(818) 765-8300	METAL OXIDE RESISTORS
RF MICRO DEVICES	(336) 664-1233	RF2138 / RF2140
SAMTEC	(800) 726-8329	WIRE JUMPERS
SANYO	(619) 661-6835	OSCON CAPS
SCHOTT	(507) 532-3201	INDUCTORS, XFORMERS
SCHURTER	(707) 778-6311	FUSES AND HOLDERS

SIGNATRON	(909) 464-1883	DB9 CONNECTORS
SIEMENS	(108) 257-7910	OPTO
SILICONIX	(800) 554-5565	MOSFETS
SILICONIX	(408) 988-8000	MOSFETS
SPRAGUE	(207) 324-4140	CAPACITORS
SULLINS	(760) 744-0125	HEADERS, SHUNTS
SUMIDA	(847) 956-0667	INDUCTORS
SUMIDA	(408) 982-9660	INDUCTORS
TAIYO YUDEN	(408) 573-4150	CHIP CAPS / RES.
TAIYO YUDEN	(800) 348-2496	CRG (CUST. RESPONSE)
TEKTRONIX	(800) 835-9433	SCOPE PROBE SOCKETS
TEMIC	(408) 970-5700	IR PHOTO DIODE
THERMALLOY	(972) 243-4321	HEAT SINKS
THIN FILM TECHNOLOGY	(507) 625-8445	THIN FILM CHIP RESISTORS
TOCOS	(847) 884-6664	SMD POTENTIOMETERS
TOKIN (NEC)	(510) 324-4110	CAPS., INDUCTORS,
TOKO	(847) 699-3430	RF PRODUCTS
TOSHIBA	(714) 455-2000	SINGLE GATE LOGIC
TOSHIBA	(949) 455-2000	LOGIC
UNITED CHEMICON	(847) 696-2000	ELECTROLYTIC CAPACITOR
VISHAY	(605) 665-9301	ZENER/SM. SIGNAL DIODES
VISHAY	(605) 665-9301	INDUCTORS, SENSE Rs
VITRAMON	(203) 268-6261	CERAMIC CHIP CAPACITOR
WIMA	(914) 347-2474	PAPER/FILM CAPACITORS
ZETEX	(631) 366-5068	SMALL SIGNAL DISCRETES
ZIERICK	(800) 882-8020	STAKED PINS



LTC CONFIDENTIAL - For Customer Use Only

REVISION HISTORY			
ECO	REV	DESCRIPTION	DATE
	1	INITIATE	02/01/02
	2	CHG T1 FTRPTS; TRACE LG ON TL1 & TL2. DEMO RELEASE	5/10/02

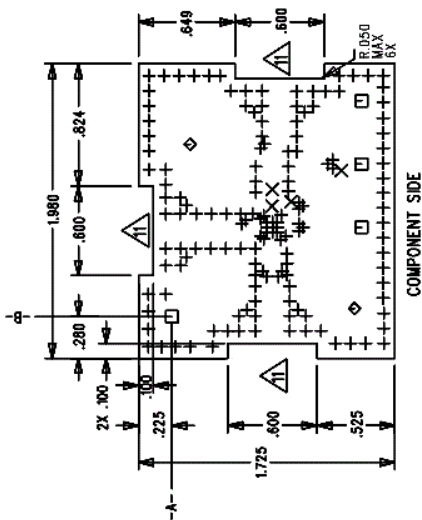

TOP  
LAYER DIELECTRIC THICKNESS  
LAYER 2 DIELECTRIC THICKNESS  
LAYER 3 DIELECTRIC THICKNESS  
LAYER 4 DIELECTRIC THICKNESS  
LAYERING STRUCTURE

HOLE SIZE CHART			
SYM	SIZE	QTY	PTH
+	.010+/--.003	148	YES
x	.015+/--.003	4	YES
□	.093+/--.003	4	YES
◇	.120+/--.003	2	YES
⊗			
⊗			

- NOTES: UNLESS OTHERWISE SPECIFIED
- ARTWORK P/N DC503A REV 2.
  - FAB PER IPC-A-600
  - MATERIAL: EPOXY FIBERGLASS, NEMA GRADE FR-4 FINISHED THICKNESS TO BE .082 +/- .005 INCH WITH 2 OZ. COPPER ON TWO OUTER LAYERS AND 1 OZ. COPPER ON TWO INTERNAL LAYERS. FLAMABILITY RATING: 94 V-0 MINIMUM.
  - OUTER DIELECTRIC THICKNESS: TARGET 50-OHM USING 30 MIL TRACE. SEE STACKUP DIAGRAM.
  - SIZE: CUT TO DIMENSIONS AND TOLERANCES SHOWN. -A- AND -B- ARE PRIMARY DATUMS.
  - DRILLING: DRILL HOLES PER SCHEDULE. PLATE THROUGH HOLES WITH COPPER. .001 INCH THICK MIN. ALL HOLE SIZES ARE SPECIFIED AFTER PLATING. HOLE LOCATION TOLERANCES ARE +/- .003 INCH IN RELATION TO CENTER
  - FINISH: SMOBC USING LPI BOTH SIDES, GREEN PREFERABLE. SILKSCREEN BOTH SIDES WITH WHITE NON-CONDUCTIVE INK.
  - DROP ALL UNUSED PADS ON INNER LAYERS.
  - DO NOT ALTER ARTWORK e.g. TO ADD LOGO OR DATE CODE. INNER AND OUTER LAYER COPPER SHALL BE EXPOSED IN TWO INSET AREAS ALONG BOARD EDGES.
  - SCORING: .020



UNLESS OTHERWISE SPECIFIED DIMENSIONS ARE IN INCHES TOLERANCES ON ANGLE ±1° 2 PLACE ±01 3 PLACE ±005 INTERPRET DIM AND TOL PER ASME Y14.5M - 1994

THIRD ANGLE PROJECTION

DO NOT SCALE DRAWING

---

CONTRACT NO

APPROVALS

DRAWN	L.SANTOS	DATE	02/01/02
CHECKED	S.HSIAO		5/10/02
APPROVED			
ENGINEER	VLAD D.		02/01/02

---

LINEAR TECHNOLOGY

1630 McCarthy Blvd.  
Milpitas, CA 95035  
Phone: (408)432-1800  
Fax: (408)434-0507

FAB, DOWNCONVERTING MIXER CATV PCB

SIZE	A	CAGE CODE	DWG NO	DC503A	REV	2
SCALE	1/1	FILENAME:	503A2.PCB	SHEET	1 OF 1	

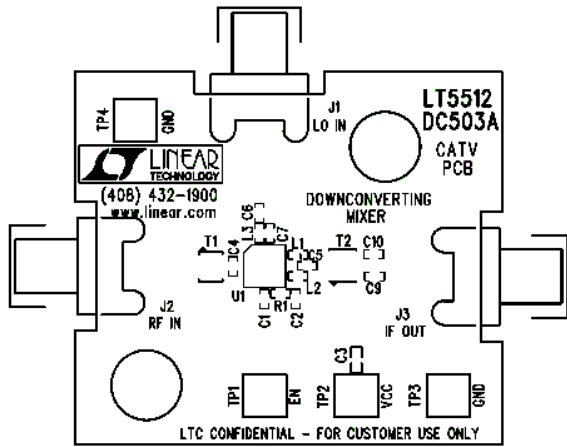

COMPANY LINEAR TECHNOLOGY CORPORATION		
TITLE A/W, LT5512 CATV PCB	NO. DC503A	REV 2
SILKSCREEN TOP		

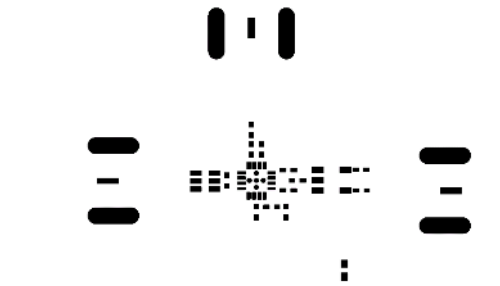

COMPANY LINEAR TECHNOLOGY CORPORATION		
TITLE A/W, LT5512 CATV PCB	NO. DC503A	REV 2
PASTE MASK TOP		

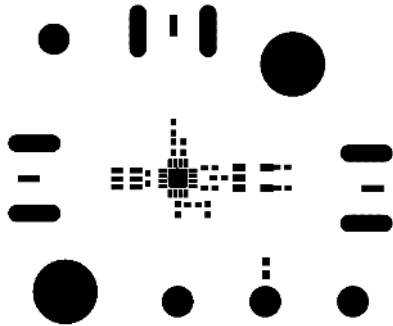

COMPANY LINEAR TECHNOLOGY CORPORATION		
TITLE A/W, LT5512 CATV PCB	NO. DC503A	REV 2
SOLDER MASK TOP		

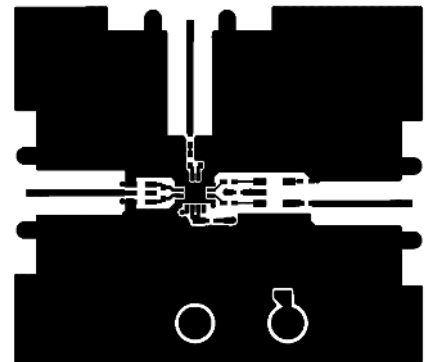

COMPANY LINEAR TECHNOLOGY CORPORATION		
TITLE A/W, LT5512 CATV PCB	NO. DC503A	REV 2
L1-COMPONENT SIDE		

DO NOT MODIFY INNER LAYER COPPER BACKOFF OUTLINE.

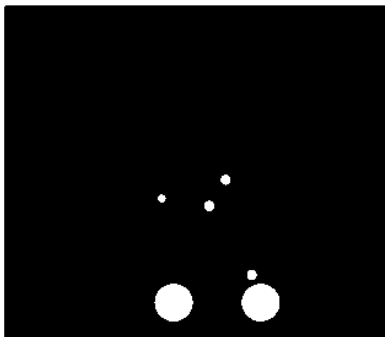

COMPANY LINEAR TECHNOLOGY CORPORATION		
TITLE A/W, LT5512 CATV PCB	NO. DC503A	REV 2
L2-GND PLANE 1		

DO NOT MODIFY INNER LAYER COPPER BACKOFF OUTLINE.

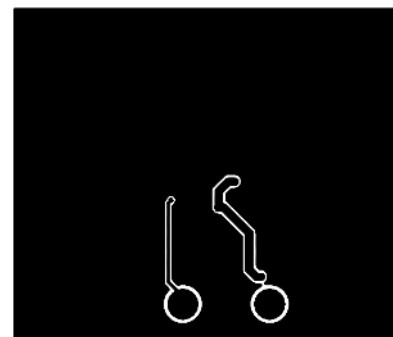

COMPANY LINEAR TECHNOLOGY CORPORATION		
TITLE A/W, LT5512 CATV PCB	NO. DC503A	REV 2
L3-GND PLANE 2		

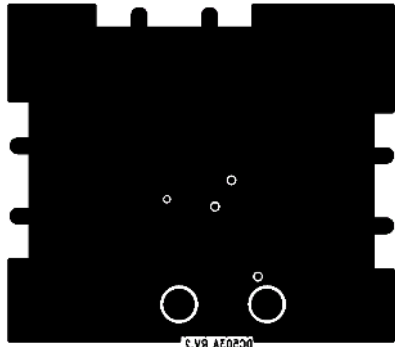

COMPANY LINEAR TECHNOLOGY CORPORATION		
TITLE A/W, LT5512 CATV PCB	NO. DC503A	REV 2
←-ORDER SIDE		

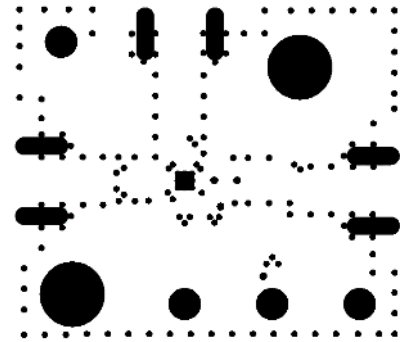

COMPANY LINEAR TECHNOLOGY CORPORATION		
TITLE A/W, LT5512 CATV PCB	NO. DC503A	REV 2
SOLDER MASK BTM		