

DWG. NO. SD-49045-001
 SIMILAR ITEM
 PROJECT NO.
 C
 B
 DO NOT SCALE DRAWING DIMENSION IN METRIC

8 7 6 5 4 3 2 1

F
 E
 D
 C
 B
 A

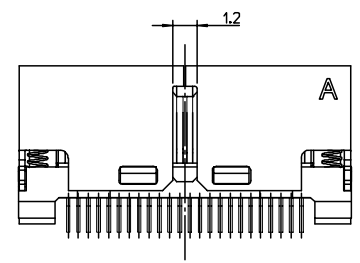
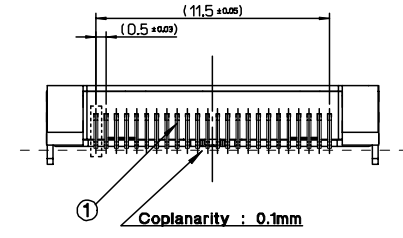
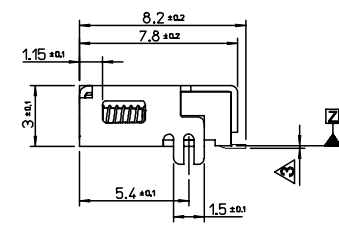
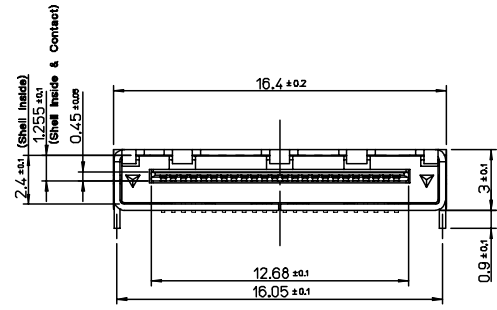
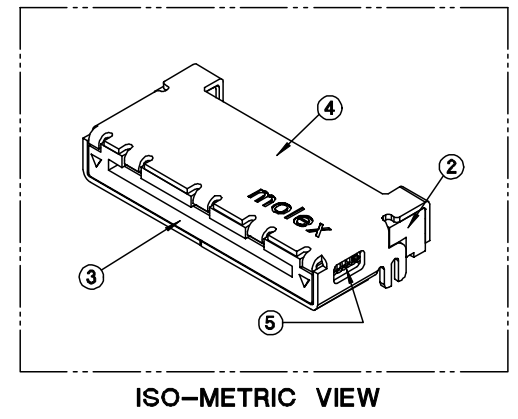
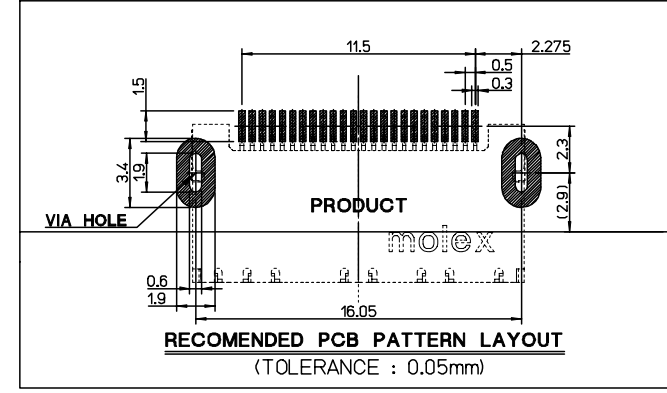
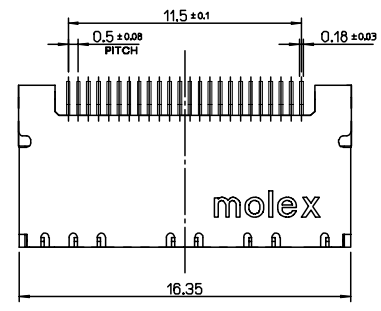

NOTES

1. MATERIALS: SEE TABLE 2
2. FINISHES: SEE TABLE 2
- ⊕ ALIGNMENT OF SOLDER TAILS FROM Z: UPPER DIRECTION 0.05 MAX. LOWER DIRECTION 0.1 MAX.
4. COPLANARITY OF SOLDER TAILS : 0.1mm MAX.
5. PRODUCT SPECIFICATION : PS-49045-001
6. PACKAGING SPECIFICATION : PK-49045-001

TABLE 1

SILVER	490450016	49045-0016
BLACK	490450011	49045-0011
COLOR	MATERIAL NO.	ENGINEERING NO.

TABLE 2

⑤	SPRING	STAINLESS STEEL	NONE
④	METAL SHELL	STAINLESS STEEL	NICKEL
③	SHUTTER	POLY AMIDE UL94V-0	BLACK / NATURAL
②	HOUSING	POLY AMIDE UL94V-0	BLACK COLOR
①	CONTACT TERMINAL	COPPER ALLOY	SELECTIVE GOLD
NO.	DESCRIPTION	MATERIAL	FINISH

REVISED	ECN NO. KOR2007-0007 DRWN: E.S.JUNG 06/07/24 CHK: S.H.JOO APPR: S.J.SEH	DESCRIPTION	QUALITY SYMBOLS MAJOR CRITICAL C	GENERAL TOLERANCES: (UNLESS SPECIFIED)		SCALE	DESIGN UNITS	DIMENSIONS:		SHT	REV
				4 PLACES ±0	3 PLACES ±0.1	2 PLACES ±0.1	1 PLACE ±0.2	4 : 1	mm / INCH	mm / INCH	mm / INCH
DRAFT WHERE APPLICABLE MUST REMAIN WITHIN DIMENSIONS				ANGULAR: ± 3 °		DRAWN BY & DATE E.S.JUNG 05/07/19		TITLE: 0.5 SHUTTER I/O CONN. 24P RECEPTACLE (WITHOUT BATTERY)			
						CHECKED BY & DATE S.H.JOO					
C				APPROVED BY & DATE S.J.SEH		CAD FILENAME SD49045001.MI		MATERIAL NO. SEE TABLE 1 DRAWING NO. SD-49045-001 SHEET NO. 1 OF 2			
						THIS DRAWING CONTAINS INFORMATION THAT IS PROPRIETARY TO MOLEX INCORPORATED AND SHOULD NOT BE USED WITHOUT WRITTEN PERMISSION.					

8 7 6 5 4 3 2 1

DO NOT SCALE DRAWING DIMENSION IN METRIC

B

C

PROJECT NO.

SIMILAR ITEM

DWG. NO. SD-49045-001

8 7 6 5 4 3 2 1

F

E

D

C

B

A

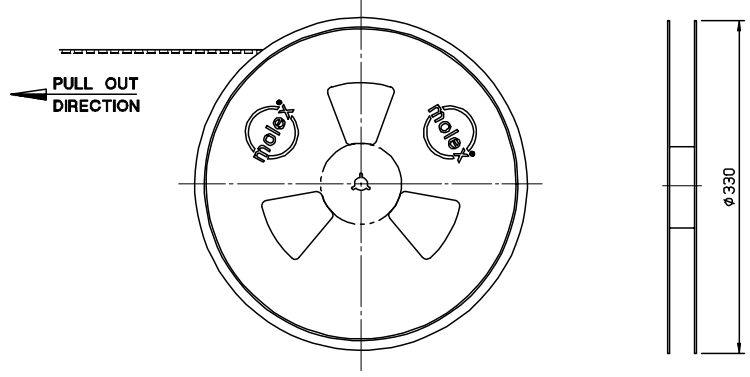

NOTES

1. QUANTITY OF CONNECTORS : 1,000PCS/REEL
2. LEAD LENGTH

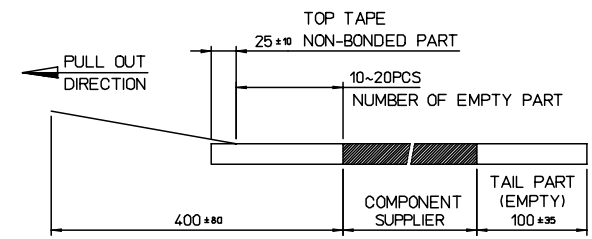

3. PEELING OFF FORCE OF COVER TAPE : 0.1N ± 0.59N(10.2 ± 60GF)
(PEELING DIRECTION AS SHOW IN FOLLOW FIG.)
- PEELING OFF SPEED : 300mm/Min.(Ref.)

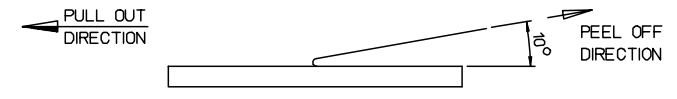

DETAIL SCALE 2:1

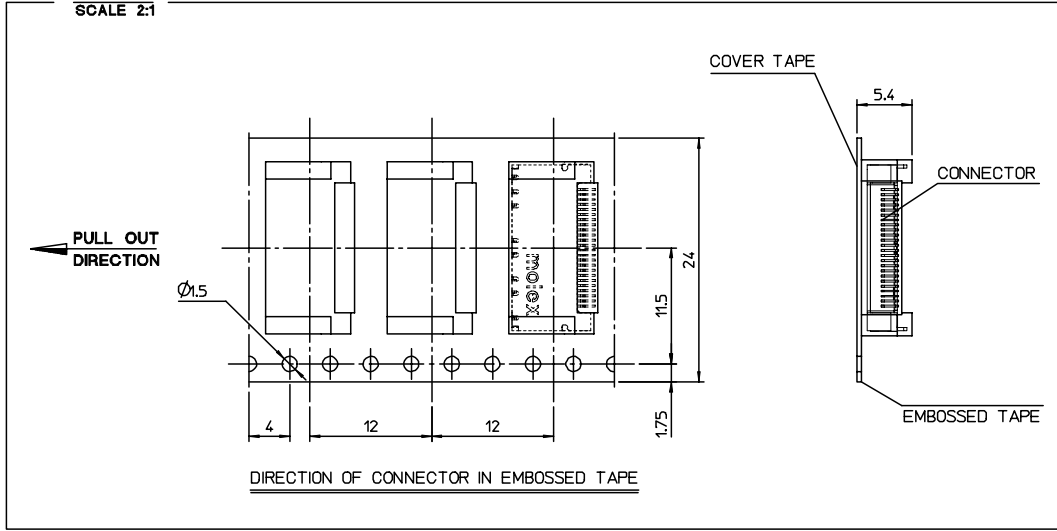

DO NOT SCALE DRAWING DIMENSION IN METRIC

RELEASE ECN NO. KOR2008-0074 DRWN: ES.JUNG 05/12/21 CHK: SH.JOO APPR: SJ.SEH	DESCRIPTION A1	QUALITY SYMBOLS	GENERAL TOLERANCES: (UNLESS SPECIFIED)	SCALE 4 : 1	DESIGN UNITS <input checked="" type="checkbox"/> mm <input type="checkbox"/> INCH	DIMENSIONS: <input type="checkbox"/> mm <input type="checkbox"/> INCH <input checked="" type="checkbox"/> mm ONLY	SHT REV	
		MAJOR =						
		CRITICAL C						
		REV						
THIRD ANGLE PROJECTION			DRAWN BY & DATE ES.JUNG 05/12/21		TITLE: 0.5 SHUTTER I/O CONN. 24P RECEPTACLE (WITHOUT BATTERY)			
CHECKED BY & DATE SH.JOO			APPROVED BY & DATE SJ.SEH		MOLEX INCORPORATED			
CAD FILENAME SD49045001.MI			MATERIAL NO. SEE TABLE 1		DRAWING NO. SD-49045-001		SHEET NO. 2 OF 2	
DRAFT WHERE APPLICABLE MUST REMAIN WITHIN DIMENSIONS			THIS DRAWING CONTAINS INFORMATION THAT IS PROPRIETARY TO MOLEX INCORPORATED AND SHOULD NOT BE USED WITHOUT WRITTEN PERMISSION.					SIZE B

8 7 6 5 4 3 2 1 KOREA MX-A3