

Screw for E85XXXXXXXX1XXX

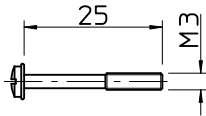

Screw and Gasket for E85XXXXXXXXQXXX

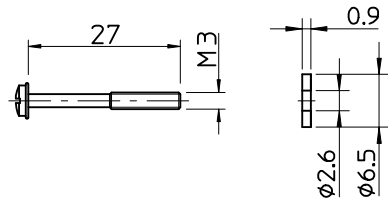

Gasket for E85XXXXXXXX1XXX

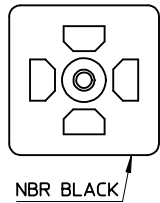

NBR BLACK

Gasket for E85XXXXXXXXQXXX

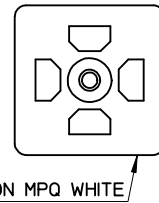

SILICON MPQ WHITE

CIRCUIT PRINTOUT WHITE

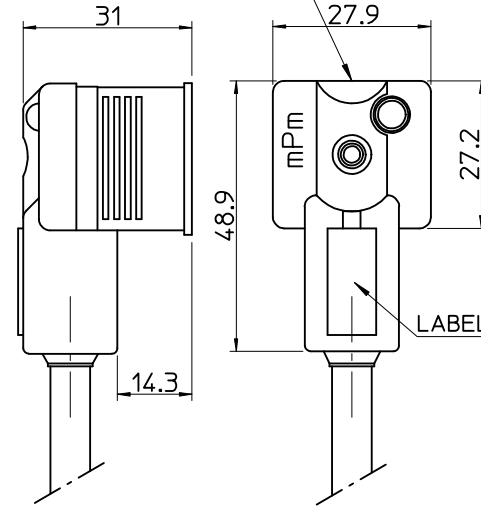

WIRING DIAGRAM FOR:

E85XXXXXXXXXXXX

E852XXXXXXXXXXXX

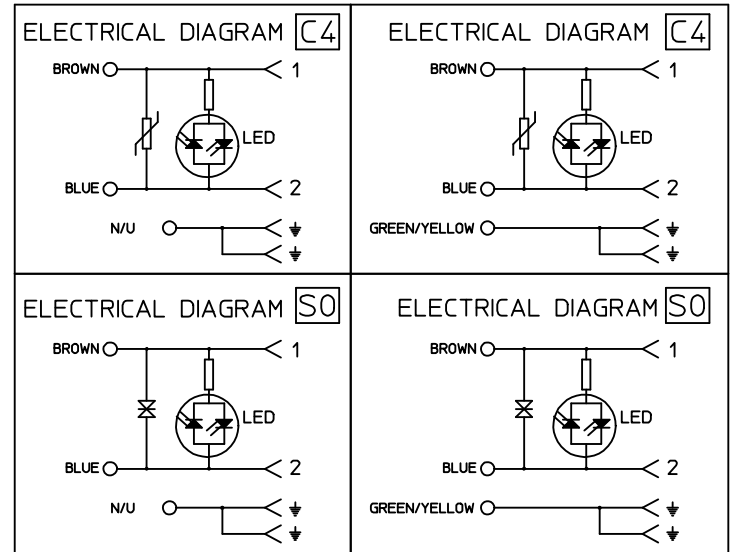

Coil cable above 1 m.
Integrated gasket and screw assembled.

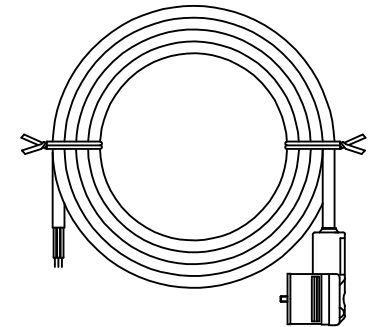

Over	Up to and including	Tolerance (+)
0	1000	±20
1000	3000	±30
3000	5000	±40
5000	10000	±50
10000	15000	±100
15000	20000	±150
20000		±L/100

ADDED E851 EC NO: IPG2016-0637 DRWN:APAWLAK01 2015/10/29 CHKD:BSTACHOWIAK 2015/10/29 APPR:MIWASIECZKO 2015/11/02	QUALITY SYMBOLS ▽=0 ◻=0	GENERAL TOLERANCES (UNLESS SPECIFIED)		DIMENSION STYLE MM ONLY		SCALE -	DESIGN UNITS METRIC	FIRST ANGLE PROJECTION
		4 PLACES ± --- ± --- 3 PLACES ± --- ± --- 2 PLACES ± --- ± --- 1 PLACE ± --- ± --- 0 PLACE ± --- ± ---	mm INCH ± --- ± --- ± --- ± --- ± --- ± --- ± --- ± ---	DRAWN BY JMARSZALEK	DATE 2012/10/01	TITLE E85XXXXXXXXXXXX CSE DIN-A W/PCB 2P+2E H6/H12 FE RA XM		
		ANGULAR ± --- °		MATERIAL NO. MIWASIECZKO 2015/09/28		DOCUMENT NO. SD-121060-001		SHEET NO. 1 OF 3
		DRAFT WHERE APPLICABLE MUST REMAIN WITHIN DIMENSIONS		MATRIX DRAWING		THIS DRAWING CONTAINS INFORMATION THAT IS PROPRIETARY TO MOLEX INCORPORATED AND SHOULD NOT BE USED WITHOUT WRITTEN PERMISSION		

10 9 8 7 6 5 4 3 2 1

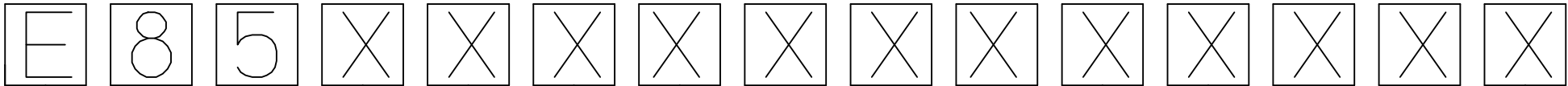

E - Packing without bags
 W - Single packing
 Q - Fast packing

NUMBER OF WIRES:
 1=2 WIRES,
 2=2 WIRES+EARTH
 3=3 WIRES+EARTH

CABLE TYPE
 SEE SHEET 3 - TABLE 1

CABLE TYPE
 SEE SHEET 3 - TABLE 2

HEAD COLOUR:
 N=BLACK,
 A=CSA-UL BLACK,
 B=CSA-UL GREY.

CABLE LENGHT IN CM
 NP:050=50 CM, 300=300 CM.

EARTH PIN LOCATION:
 1=DOUBLE EARTH ON 6H AND 12H.

GASKET AND SCREWS:
 1=INTEGRATED GASKET NBR BLACK+FIXING SCREW (M3x25 mm).
 0=INTEGRATED GASKET SILICONE WHITE+SCREW+GROMMET (M3x27 mm).

INTERNAL CIRCUIT
 WIRING CONFIGURATION - SEE SHEET 1

VOLTAGE AND LED COLOUR:

1= 12V	A= 12V	G= 12V
2= 24V	B= 24V	H= 24V
3= 48V	C= 48V	K= 48V
4= 115V	D= 115V	L= 115V
5= 230V	E= 230V	M= 230V

RED LED GREEN LED YELLOW LED

List of E851 PN's

Molex PN:	Engineering No.:	L [mm]
1210600012	E851I4N30011C4H	3000
1210600013	E851I4N50011C4H	5000
1210600014	E851I4N10K11C4H	10000
1210600015	E851I4N20011C4H	2000
1210600029	E851P3A50010C4B	5000
1210600030	E851P3A30010C4B	3000
1210600031	E851P3A20010C4B	2000
1210600032	E851P3A10010C4B	1000
1210600033	E851P3A05010C4B	500
1210600034	E851B3A02010C4B	200
1210600044	E851B3A05010C4B	500
1210600045	E851B3A10010C4B	1000
1210600048	E851B3A20010C4B	2000

List of E852 PN's

Molex PN:	Engineering No.:	L [mm]
1210600040	E852P3A30011S0H	3000
1210600041	E852P3A50011S0H	5000

ADDED E851 EC NO: IPG2016-0637 DRWN:APAWLAK01 2015/10/29 CHKD:STACHOWIAK 2015/10/29 APPR:MIWASIECZKO 2015/11/02	QUALITY SYMBOLS	GENERAL TOLERANCES (UNLESS SPECIFIED)	DIMENSION STYLE MM ONLY	SCALE -	DESIGN UNITS METRIC	FIRST ANGLE PROJECTION																																					
		<table border="1"> <tr><th></th><th>mm</th><th>INCH</th></tr> <tr><td>4 PLACES</td><td>± ---</td><td>± ---</td></tr> <tr><td>3 PLACES</td><td>± ---</td><td>± ---</td></tr> <tr><td>2 PLACES</td><td>± ---</td><td>± ---</td></tr> <tr><td>1 PLACE</td><td>± ---</td><td>± ---</td></tr> <tr><td>0 PLACE</td><td>± ---</td><td>± ---</td></tr> </table>		mm	INCH	4 PLACES	± ---	± ---	3 PLACES	± ---	± ---	2 PLACES	± ---	± ---	1 PLACE	± ---	± ---	0 PLACE	± ---	± ---	<table border="1"> <tr><th colspan="2">DRAWN BY</th><th>DATE</th></tr> <tr><td>JMARSZALEK</td><td></td><td>2012/10/01</td></tr> <tr><th colspan="2">CHECKED BY</th><th>DATE</th></tr> <tr><td>MSZWAJKOWSKI</td><td></td><td>2013/07/25</td></tr> <tr><th colspan="2">APPROVED BY</th><th>DATE</th></tr> <tr><td>MIWASIECZKO</td><td></td><td>2015/09/28</td></tr> </table>	DRAWN BY		DATE	JMARSZALEK		2012/10/01	CHECKED BY		DATE	MSZWAJKOWSKI		2013/07/25	APPROVED BY		DATE	MIWASIECZKO		2015/09/28	TITLE	E85XXXXXXXXXXXXX CSE DIN-A W/PCB 2P+2E H6/H12 FE RA XM 		
		mm	INCH																																								
	4 PLACES	± ---	± ---																																								
3 PLACES	± ---	± ---																																									
2 PLACES	± ---	± ---																																									
1 PLACE	± ---	± ---																																									
0 PLACE	± ---	± ---																																									
DRAWN BY		DATE																																									
JMARSZALEK		2012/10/01																																									
CHECKED BY		DATE																																									
MSZWAJKOWSKI		2013/07/25																																									
APPROVED BY		DATE																																									
MIWASIECZKO		2015/09/28																																									
DRAFT WHERE APPLICABLE MUST REMAIN WITHIN DIMENSIONS	MATERIAL NO. MATRIX DRAWING	DOCUMENT NO. SD-121060-001	SHEET NO. 2 OF 3	THIS DRAWING CONTAINS INFORMATION THAT IS PROPRIETARY TO MOLEX INCORPORATED AND SHOULD NOT BE USED WITHOUT WRITTEN PERMISSION																																							
REV	SIZE A3																																										

9 8 7 6 5 4 3 2 1

TABLE 2 - CABLES

TABLE 2 - CABLES

Molex PN Raw cable	Cable type	Cable code	Wires no.	Cross Section	Jacket material	Jacket color	Diameter Ø [mm]	Wire colors
1210180384	R	3	3	0.75 mm ²	TPR HAL. FREE	Black	6.5±0.2	BN, BU, GN/YE
1210180094	T	3	3	0.75 mm ²	PUR CSA/UL 20668	Yellow	6.5±0.2	BN, BU, GN/YE
1210180309	Y	3	3	0.75 mm ²	SILICONE RUBBER	Red	6.5±0.2	BN, BU, GN/YE
1210180081	F	4	3	1 mm ²	PVC CNOMO	Grey	7.1+0.2/-0	BK1, BK2, GN/YE
1210180042	I	4	2	1 mm ²	PVC CEI 2022 II O.R.	Grey	7.1+0.2/-0	BN, BU
1210180079	I	4	3	1 mm ²	PVC CEI 2022 II O.R.	Grey	7.1+0.2/-0	BN, BU, GN/YE
1210180038	N	4	2	1 mm ²	PVC H05VV-F	Black	6.5±0.2	BN, BU
1210180082	N	4	3	1 mm ²	PVC H05VV-F	Black	6.9±0.2	BN, BU, GN/YE
1210180117	R	4	3	1 mm ²	TPR HAL. FREE	Black	7.1±0.2	BN, BU, GN/YE
1210180085	N	5	3	1.5 mm ²	PVC H05VV-F	Black	7.9±0.2	BN, BU, GN/YE
1210180313	I	6	2	0.35 mm ²	PVC CEI 2011	Grey	4.8±0.2	BN, WH
1210180149	I	9	4	0.75 mm ²	PVC CEI 2022 II	Grey	7.3±0.2	BN, BU, BK, GN/YE

TABLE 1 - TYPES OF CABLES

Code	Cable types	Features	Cross Section
N	PVC	Application general purpose cable which has good resistance to water, but usually poor oil resistance.	0.5 mm ² 0.75 mm ² 1 mm ²
I	CEI	Approved to IEC 332-2A, flame retardant and self extinguishing. Limited resistant to mineral oils.	0.5 mm ² 0.75 mm ² 1 mm ²
P	PUR	Offer good resistance to oil and chemicals. Can swell when constantly immersed in water.	0.5 mm ² 0.75 mm ² 1 mm ²
A	PVC CSA-UL	Approved to CSA-UL 2661, application general purpose cable which has good resistance to water, but usually poor oil resistance.	20 AWG 18 AWG
B	PUR CSA-UL	Approved to CSA-UL 20668, very good resistance to oil and chemicals.	20 AWG 18 AWG

ADDED E851 EC NO: IPG2016-0637 DRWN:APAWLAK01 2015/10/29 CHKD:BSTACHOWIAK 2015/10/29 APPR:MIWASIECZKO 2015/11/02	DESCRIPTION REV	QUALITY SYMBOLS	GENERAL TOLERANCES (UNLESS SPECIFIED)	DIMENSION STYLE	SCALE	DESIGN UNITS	FIRST ANGLE PROJECTION
		▽=0 ◻=0	mm INCH	MM ONLY	-	METRIC	
		4 PLACES ± --- ± --- 3 PLACES ± --- ± --- 2 PLACES ± --- ± --- 1 PLACE ± --- ± --- 0 PLACE ± --- ± ---	DRAWN BY DATE JMARSZALEK 2012/10/01 CHECKED BY DATE MSZWAJKOWSKI 2013/07/25 APPROVED BY DATE MIWASIECZKO 2015/09/28	TITLE	E85XXXXXXXXXXXXX CSE DIN-A W/PCB 2P+2E H6/H12 FE RA XM		
		ANGULAR ± --- ° DRAFT WHERE APPLICABLE MUST REMAIN WITHIN DIMENSIONS	MATERIAL NO. MATRIX DRAWING SIZE A3	DOCUMENT NO. SD-121060-001 SHEET NO. 3 OF 3			