

MATERIAL NO.	ENG. NO.	STUD SIZE	ØS ±.005
190710210	E-659-12X	1/2	.515
190710211	E-659-14X	1/4	.265
190710212	E-659-34X	3/4	.781
190710213	E-659-38X	3/8	.390
190710214	E-659-56X	5/16	.328
190710215	E-659-58X	5/8	.656
190710216	E-659-76X	7/16	.453

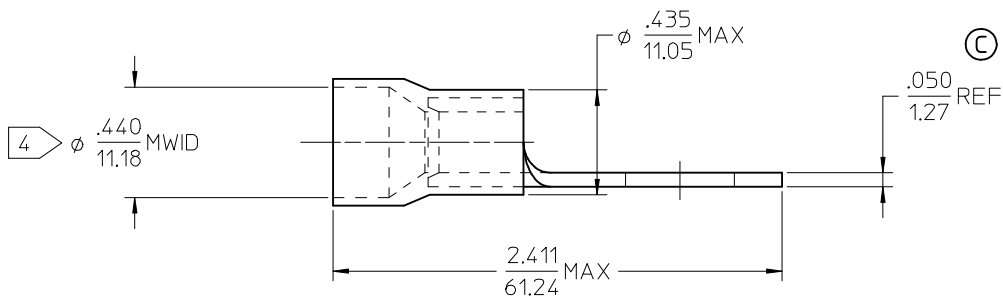
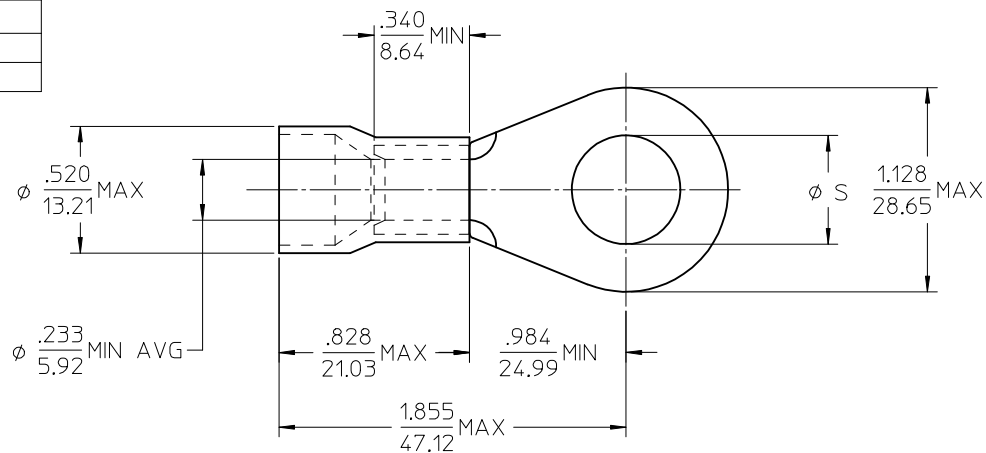

NOTE(S):

1. TERMINAL MATERIAL: COPPER ALLOY.
2. TERMINAL FINISH: ELECTRO TIN PLATE.
3. INSULATION MATERIAL: PVC, COLOR CODED BLUE.
4. MWID = MAXIMUM WIRE INSULATION DIAMETER.
5. ALL COMPONENTS ARE ROHS COMPLIANT.

REDWN & RDC MATL THKNS EC NO: DRW:EHILE CHKD:JMACNEIL APPR:	DESCRIPTION 2006/10/10	QUALITY SYMBOLS	GENERAL TOLERANCES (UNLESS SPECIFIED)	DIMENSION STYLE	SCALE	DESIGN UNITS	THIRD ANGLE PROJECTION
		▽=0	mm INCH	IN/MM	4:1	INCH	
		∇=0	4 PLACES ±--- ±---	DRAWN BY DATE	RING TONGUE TERMINAL INSULKRIMP, 659 SERIES 6 AWG MOLEX INCORPORATED		
			3 PLACES ±--- ±---	CHECKED BY DATE			
	2 PLACES ±--- ±---	JMACNEIL 2006/10/10					
	1 PLACE ±--- ±---	JMACNEIL 2006/10/10					
	ANGULAR ±---°	DRAFT WHERE APPLICABLE MUST REMAIN WITHIN DIMENSIONS		SEE CHART	MATERIAL NO.	DOCUMENT NO.	SHEET NO.
				SIZE B	THIS DRAWING CONTAINS INFORMATION THAT IS PROPRIETARY TO MOLEX INCORPORATED AND SHOULD NOT BE USED WITHOUT WRITTEN PERMISSION		1 OF 1