



3.3V LOW NOISE 1:9 FANOUT BUFFER DC – 4.5GHz

ADH987S

1.0 Scope

This specification documents the detail requirements for an internally defined equivalent flow per MIL-PRF-38535 Level V expect as modified herein.

The manufacturing flow described in the RF & MICROWAVE STANDARD SPACE LEVEL PRODUCTS PROGRAM is to be considered a part of this specification.

This data specifically details the space grade version of this product. A more detailed operational description and a complete data sheet for commercial product grades can be found at <http://www.analog.com/HMC987>

2.0 Part Number:

The complete part number(s) of this specification follows:

<u>Specific Part Number</u>	<u>Description</u>
ADH987R701G32	DC to 4.5 GHz, 3.3 V Low Noise 1:9 Fanout Buffer

3.0 Case Outline

The case outline is as follows:

<u>Outline Letter</u>	<u>Descriptive Designator</u>	<u>Terminals</u>	<u>Lead Finish</u>	<u>Package style</u>
X	FR-32-1	32 Lead	Gold	Glass/Metal Hermetic SMT (G32)

ASD0016580

Rev. B

Information furnished by Analog Devices is believed to be accurate and reliable. However, no responsibility is assumed by Analog Devices for its use, nor for any infringements of patents or other rights of third parties that may result from its use. Specifications subject to change without notice. No license is granted by implication or otherwise under any patent or patent rights of Analog Devices. Trademarks and registered trademarks are the property of their respective companies.

One Technology Way, P.O. Box 9106, Norwood, MA 02062-9106, U.S.A.
Tel: 781.329.4700 www.analog.com
Fax: 781.326.8703 © 2021 Analog Devices, Inc. All rights reserved.

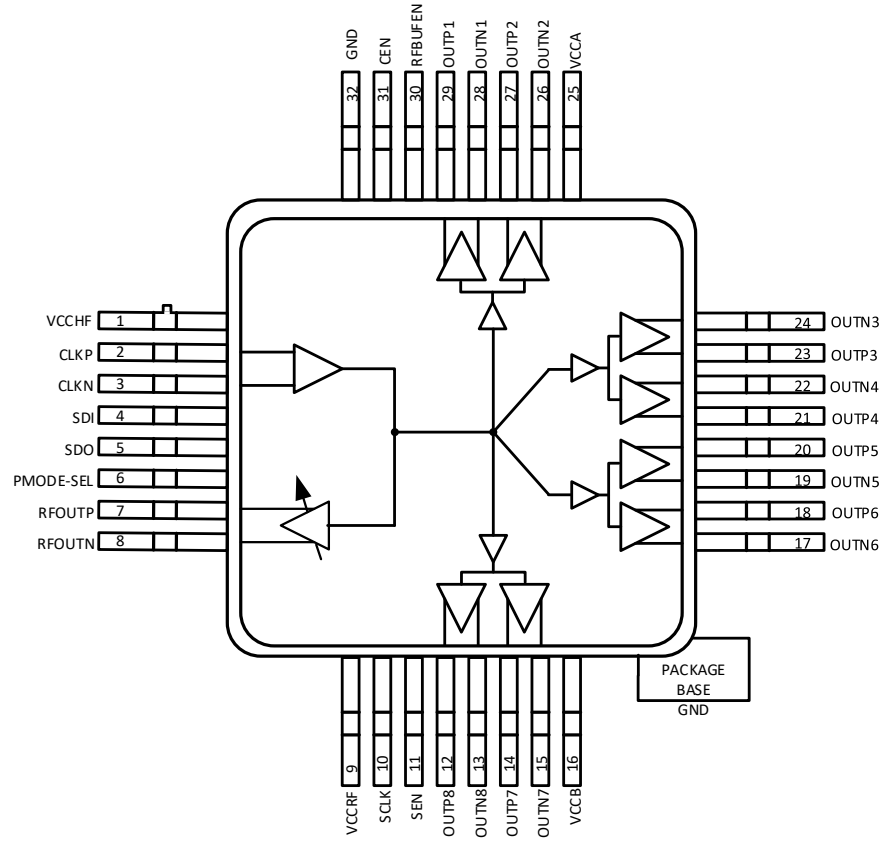

Figure 1 Functional Block Diagram 1/

1/ Top view of package

Pin Number	Terminal Symbol	Pin Type	Pin Description
1	VCCHF	Power	Power Supply
2	CLKP	Analog Input	Differential clock inputs
3	CLKN	Analog Input	
4	SDI	Digital Input	Serial port data input
5	SDO	Digital Output	Serial port data output
6	PMODE-SEL	Digital Input	In Parallel mode (PMODE-SEL =1): Pins (SCLK, SDI, SEN) are interpreted as a control-word which enables different buffers In Serial mode (PMODE-SEL =0): Reg02h enables which buffer combination(s) can be enabled or disabled
7	RFOUTP	Analog Output	Differential RF output buffer signal output
8	RFOUTN	Analog Output	
9	VCCRF	Power	Power supply
10	SCLK	Digital Input	Serial port clock
11	SEN	Digital Input	Serial port latch enable
12	OUTP8	Analog Output	Differential signal output
13	OUTN8	Analog Output	
14	OUTP7	Analog Output	Differential signal output
15	OUTN7	Analog Output	
16	VCCB	Power	Power Supply
17	OUTN6	Analog Output	Differential signal output
18	OUTP6	Analog Output	
19	OUTN5	Analog Output	Differential signal output
20	OUTP5	Analog Output	
21	OUTP4	Analog Output	Differential signal output
22	OUTN4	Analog Output	
23	OUTP3	Analog Output	Differential signal output
24	OUTN3	Analog Output	
25	VCCA	Power	Power Supply
26	OUTN2	Analog Output	Differential signal output
27	OUTP2	Analog Output	
28	OUTN1	Analog Output	Differential signal output
29	OUTP1	Analog Output	
30	REFBUFEN	Digital Input	Active high RF buffer enable. The polarity of this control input can be swapped via SPI bit Reg 0x3[4]
31	CEN	Digital Input	Hardware Chip Enable. Logic 0 = Power Down Logic 1 = Active
32	GND	Power	RF/DC Ground
Package Bottom	GND	Power	RF/DC Ground ^{1/}
Package Lid		NIC	No Internal Connection. Package Lid is not connected to RF/DC ground.

Figure 2 – Terminal Connections

^{1/} The package bottom has an exposed metal pad that must connect the printed circuit board (PCB) RF/DC ground.

4.0 Specifications

4.1. Absolute Maximum Ratings ^{1/}

VCCHF, VCCRF, VCCA, VCCB to ground	-0.3 V to +4 V
Max RF Power on pins CLKP, CLKN	+15 dBm single-ended
LVPECL Min Output Load Resistor	100 Ohms to GND
LVPECL Output Load Current	40 mA/Leg
Digital Load	1 k Ω Min
Digital Input Voltage Range	-0.3 V to 3.6 V
Thermal Resistance (Junction to ground paddle)	18.8 $^{\circ}$ C/W
Operating Temperature Range	-40 $^{\circ}$ C to +85 $^{\circ}$ C
Storage Temperature Range	-65 $^{\circ}$ C to +125 $^{\circ}$ C
Maximum Junction Temperature	+125 $^{\circ}$ C
ESD Sensitivity (HBM).....	Class 1B

4.2. Recommended Operating Conditions

Supply voltage (VCCHF = VCCRF = VCCA = VCCB)	+3.3 V (Regulated)
Ambient operating temperature range (T _A).....	-40 $^{\circ}$ C to +85 $^{\circ}$ C

4.3. Nominal Operating Performance Characteristics ^{2/}

Max Vil	1.1 V
Min Vih	2.0 V
Max Vol	0.4 V
Min Voh	2.3 V
Single-Ended Input Impedance (Selectable)	50 / 150 Ω
Output Third Order Intercept (IP3) (16GHz – 18GHz)	25 dBm

4.4. Radiation Features

Maximum total dose available (dose rate = 50 – 300 rads (Si)/s).... 100 krad (Si)

Single event phenomenon (SEP):

No single event latchup (SEL) occurs at effective linear energy

transfer (LET) \leq 80 MeV-cm²/mg ^{3/}

^{1/} Stresses above those listed under Absolute Maximum Ratings may cause permanent damage to the device. This is a stress rating only; functional operation of the device at these or any other conditions outside of those indicated in the operation sections of this specification is not implied. Exposure to absolute maximum ratings for extended periods may affect device reliability.

^{2/} All typical specifications are at T_A = 25 $^{\circ}$ C and regulated VDD of 3.3 V, unless otherwise noted.

^{3/} Limits are characterized at initial qualification and after any design or process changes that may affect the SEP characteristics, but are not production tested unless specified by the customer through purchase order or contract. For more information on single event effect (SEE) test results, customers are requested to contact ADI.

TABLE IA – ELECTRICAL PERFORMANCE CHARACTERISTICS (VDD = +3.3 V)

Parameter See notes at end of table	Symbol	Conditions 1/ Unless otherwise specified	Sub-Group	Limit Min	Limit Max	Units
Frequency = 0.5 GHz 3/						
OUTP1 & OUTN1 Output Power	Pout	RF Pin = -10 dBm	4	-0.5		dBm
			5, 6	-1.5		dBm
RF Buffer RFOUTP & RFOUTN Output Power	Pout	RF Pin = -10 dBm	4	-0.5		dBm
			5, 6	-1.5		dBm
Frequency = 1.5 GHz 2/						
OUTP1-8 & OUTN1-8 Output Power	Pout	RF Pin = -10 dBm	4	-1.5		dBm
			5, 6	-2.5		dBm
		RF Pin = +5 dBm	4	-0.5		dBm
			5, 6	-1.5		dBm
RF Buffer RFOUTP & RFOUTN Output Power	Pout	RF Pin = -10 dBm	4	-0.5		dBm
			5, 6	-1.5		dBm
	Pout	RF Pin = +5 dBm	4	1.0		dBm
			5, 6	0.0		dBm
Frequency = 2.5 GHz 3/						
OUTP1 & OUTN1 Output Power	Pout	RF Pin = -10 dBm	4	-3.0		dBm
			5, 6	-4.0		dBm
RF Buffer RFOUTP & RFOUTN Output Power	Pout	RF Pin = -10 dBm	4	-0.5		dBm
			5, 6	-1.5		dBm
Frequency = 3.5 GHz 3/						
OUTP1 & OUTN1 Output Power	Pout	RF Pin = -10 dBm	4	-4.0		dBm
			5, 6	-5.0		dBm
RF Buffer RFOUTP & RFOUTN Output Power	Pout	RF Pin = -10 dBm	4	-2.0		dBm
			5, 6	-3.0		dBm
Frequency = 4.5 GHz 3/						
OUTP1 & OUTN1 Output Power	Pout	RF Pin = -10 dBm	4	-6.0		dBm
			5, 6	-7.0		dBm
RF Buffer RFOUTP & RFOUTN Output Power	Pout	RF Pin = -10 dBm	4	-6.0		dBm
			5, 6	-7.0		dBm
Noise						
Harmonics 7/	Fo	RF Pin = 6 dBm, 4.2 GHz 3/4/	4,5,6	-5.0		dBm
	2Fo		4,5,6		-16	dBc
	3Fo		4,5,6		-27	dBc
	4Fo		4,5,6		-34	dBc
	5Fo		4,5,6		-36	dBc
Phase Noise Floor	PNF	RF Pin = 3 dBm, 4.2 GHz 3/ 4/	4,5,6		-157	dBc/Hz
		RF Pin = 6 dBm, 4.2 GHz 4/ 5/	4,5,6		-159	dBc/Hz
		RF Pin = 6 dBm, 2 GHz 4/ 5/6/	4,5,6		-155	dBc/Hz
Quiescent						
Supply Current	Idd	All Ports On	1, 2, 3		440	mA
			MDPL	1		
Power Down Current 8/	IDDQ	CEN = 0 V	1		2	uA
			MDPL	1		2
Digital Input Leakage Current 8/	IIH	Vi = 2 V	1	-10	10	uA
			MDPL	1	-10	10
	IIL	Vi = 0 V	1	-10	10	uA
			MDPL	1	-10	10

TABLE IA NOTES:

ADH987S

- 1/ VDD (VCCHF = VCCA = VCCB = VCCRF = 3.3V nom), T_A nom = +25 °C, T_A max = +85 °C, T_A min = -40 °C, Continuous wave single-ended AC coupled clock input with 200 Ω LVPECL termination, Unused clock input decoupled to GND with 100pF unless otherwise noted.
- 2/ Clock input driven on CLKP and CLKN.
- 3/ Clock input driven on CLKP input only.
- 4/ Output not corrected for board, cable and adapter loss
- 5/ Clock input driven differentially. Outputs are single-ended.
- 6/ Measurement on RFOUT pins. See RF Output Buffer Phase Noise Floor at 2 GHz vs. Input Power plot in Section 7
- 7/ Parameter not tested post irradiation. Parameter is part of device initial characterization which is only repeated after design and process changes or with subsequent lots.
- 8/ Limits are characterized at initial qualification and after any design or process changes that may affect the TID characteristics, but are not Production tested unless specified by the customer through purchase order or contract. For more information on total ionizing dose (TID) test results, customers are requested to contact ADI.

TABLE IIA – ELECTRICAL TEST REQUIREMENTS:

Table IIA	
Test Requirements	Subgroups (in accordance with MIL-PRF-38535, Table III)
Interim Electrical Parameters	1, 4
Final Electrical Parameters	1,4 <u>1/</u> <u>2/</u>
Group A Test Requirements	1,2,3, 4,5,6
Group C end-point electrical parameters	1, 4 <u>2/</u>
Group D end-point electrical parameters	1, 4
Group E end-point electrical parameters	1 <u>3/</u>

Table IIA Notes:

1/ PDA applies to Table I subgroup 1 and Table IIB delta parameters.

2/ See Table IIB for delta parameters

3/ Parameters noted in Table I are not tested post irradiation.

TABLE IIB – BURN-IN / LIFE TEST DELTA LIMITS 1/ 2/ 3/

Table IIB				
Parameter	Test Conditions	Symbol	Delta	Units
OUTP1-8 & OUTN1-8 Output Power	Pin = -10 dBm, Single Ended AC CLKP Input	Pout	± 1.0	dB
	Pin = -10 dBm, Single Ended AC CLKN Input	Pout	± 1.0	dB
OUTP1-8 & OUTN1-8 Output Power	Pin = +5 dBm, Single Ended AC CLKP Input	Pout	± 1.0	dB
	Pin = +5 dBm, Single Ended AC CLKN Input	Pout	± 1.0	dB
RF Buffer RFOUTP & RFOUTN Output Power	Pin = -10 dBm, Single Ended AC CLKP Input	Pout	± 1.0	dB
	Pin = -10 dBm, Single Ended AC CLKN Input	Pout	± 1.0	dB
RF Buffer RFOUTP & RFOUTN Output Power	Pin = +5 dBm, Single Ended AC CLKP Input	Pout	± 1.0	dB
	Pin = +5 dBm, Single Ended AC CLKN Input	Pout	± 1.0	dB
Supply Current	All Ports On, No RF Input signal	Icc	± 10	%

1/ 240-hour burn in and group C end point electrical parameters.

2/ Deltas are performed at room temperature T_A = +25 °C only.

3/ Deltas apply with VDD = 3.3 V, Frequency = 1.5 GHz unless otherwise noted

5.0 **Burn-In Life Test, and Radiation**

5.1. Burn-In Test Circuit, Life Test Circuit

5.1.1. The test conditions and circuit shall be maintained by the manufacturer under document revision level control and shall be made available to the preparing or acquiring activity upon request. The test circuit shall specify the inputs, outputs, biases, and power dissipation, as applicable, in accordance with the intent specified in method 1015 test condition D of MIL-STD-883.

5.1.2. HTRB is not applicable for this drawing.

5.2. Radiation Exposure Circuit

5.2.1. The radiation exposure circuit shall be maintained by the manufacturer under document revision level control and shall be made available to the preparing and acquiring activity upon request. Total dose irradiation testing shall be performed in accordance with MIL-STD-883 method 1019, condition A.

6.0 **MIL-PRF-38535 QMLV Exceptions**

The manufacturing flow described in the RF & MICROWAVE STANDARD SPACE LEVEL PRODUCTS PROGRAM is to be considered a part of this specification. The brochure describes standard QMLV exceptions for Aerospace products run at the ADI Chelmsford, MA facility

6.1. Wafer Fabrication

Foundry information is available upon request.

6.2. Device Assembly

Device contains bi-metallic wire bonds (Gold bond wires on Aluminum die pads).

6.3. Group D

Group D-5 Salt Atmosphere testing is not performed.

7.0 **Application Notes**

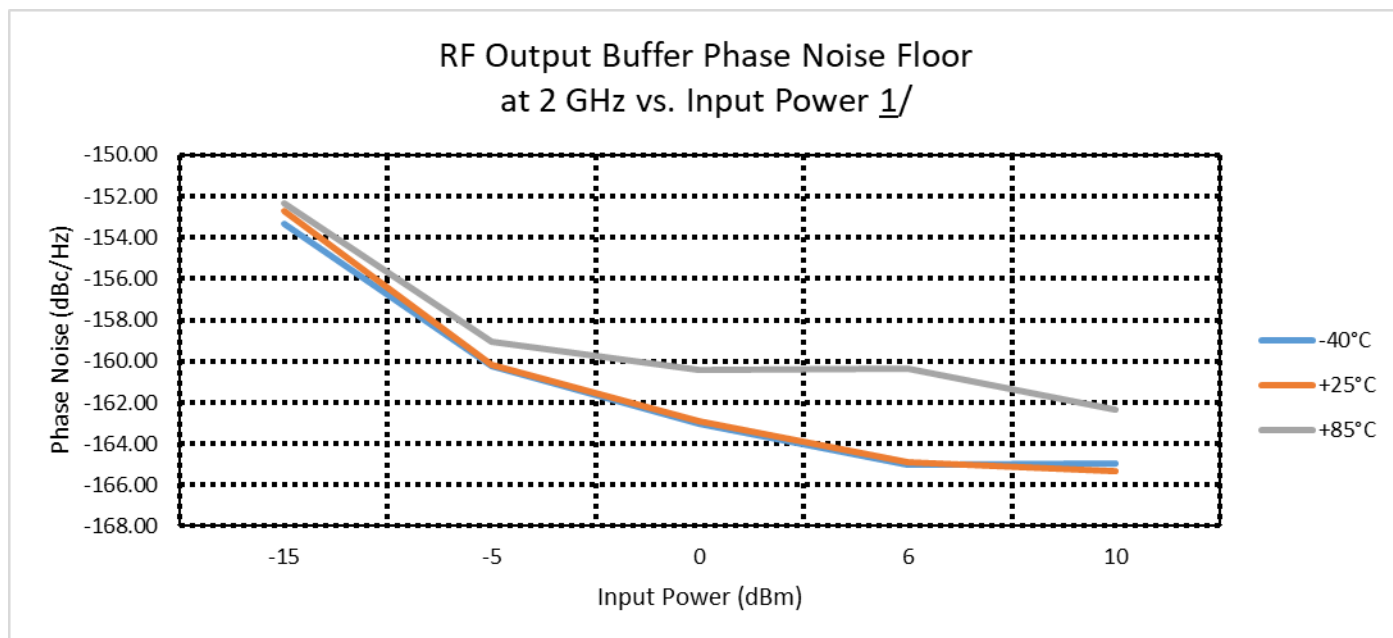

1/ Output not corrected for board, cable and adapter loss. Clock input driven differentially. Outputs are single-ended. Not tested post irradiation. Parameter is part of device initial characterization which is only repeated after design and process changes or with subsequent lots.

PARALLEL PORT CONTROL

The various outputs of the can be enabled/disabled by using parallel pin control, or via the SPI. In parallel-mode (PMODE-SEL = 1), the SPI input pins (SCLK, SDI, SEN) are re-interpreted as a 3-bit control bus, and enable the LVPECL drivers according to the following truth table.

SCLK, SDI, SEN

```

000: OUT 2
001: OUT 2 + OUT 7
010: OUT 2 + OUT 7 + OUT 4
011: OUT 2 + OUT 7 + OUT 4 + OUT 6
100: OUT 2 + OUT 7 + OUT 4 + OUT 6 + OUT 5
101: OUT 2 + OUT 7 + OUT 4 + OUT 6 + OUT 5 + OUT 3
110: OUT 2 + OUT 7 + OUT 4 + OUT 6 + OUT 5 + OUT 3 + OUT 8
111: OUT 2 + OUT 7 + OUT 4 + OUT 6 + OUT 5 + OUT 3 + OUT 8 + OUT 1

```

Under SPI control (PMODE-SEL = 0, see section "Register Map" for the register map and SPI protocol details), there is slightly more flexibility in that any combination of buffers can be enabled or disabled via the individual buffer enable bits in Reg 0x2.

The part features switches on both the input and output signals, so that when the part is disabled (via either the CEN pin, or the SPI control bit Reg 0x1[0]), the power-down current drops to < 2 μ A, regardless of the IO termination scheme.

INPUT STAGE

The input stage, Figure 2, is flexible. It can be driven single-ended or differential, with LVPECL, LVDS, or CML signals. If driven single-ended, a large AC coupling cap to ground should be used on the undriven input. The input impedance is selectable, via Reg 0x3[3], between 50 Ω or 150 Ω single ended (100 Ω or 300 Ω differential). The DC bias level of 2.0 V can be generated internally by programming Reg 0x03[1]=1 (default configuration), supplied externally, or generated via an LVPECL termination network inside the part.

ADH987S

CHIP ENABLE

The ADH987S has a chip enable feature, (CEN) which can be used to power down or deactivate the LVPECL and RF outputs. This can be done with either the CEN device pin (pin 31,) or with a SPI command to Reg 0x01[0].

The ADH987S enters power-down when a logic 0 is applied to the CEN pin. However, SPI commands can still be written and are recognized when a logic 1 is applied to CEN. Note, there is no internal pull-up or pull-down and this pin must be terminated. To control the chip enable feature via SPI, the first bit in Reg 0x01 is set to the desired state. Setting this bit to 1, which is the default mode, enables the outputs. Setting this bit to 0 disables the outputs.

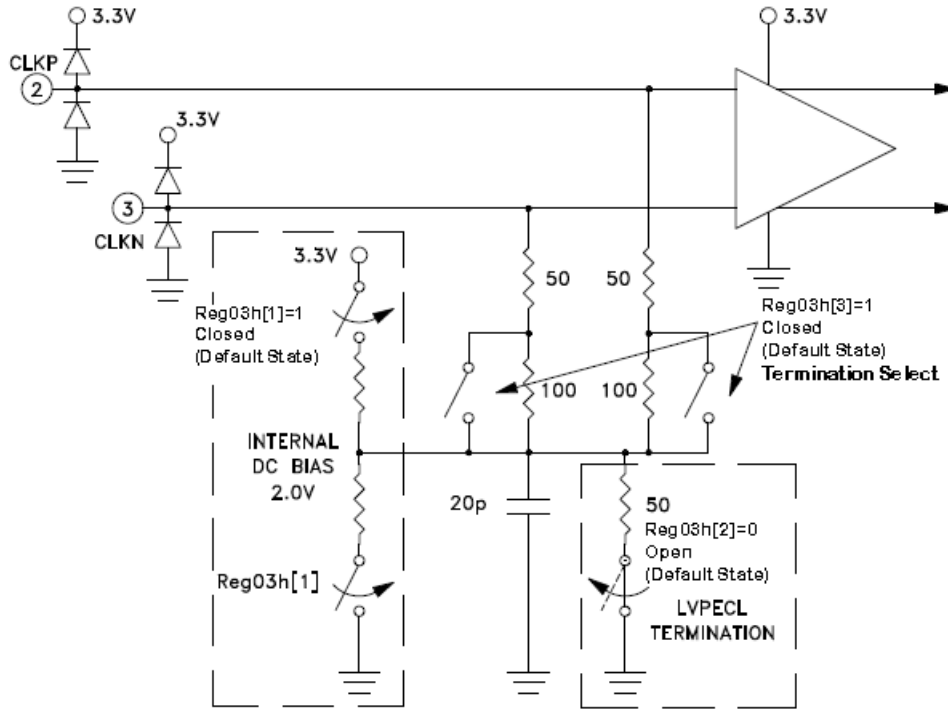

Figure 3 Input Stage

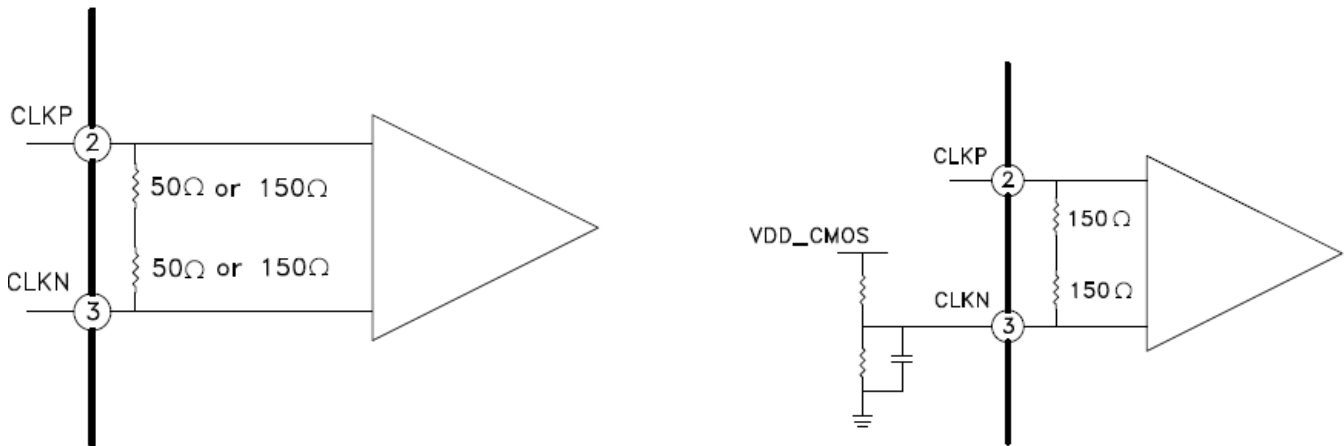

Figure 4 DC Coupled CML Interface

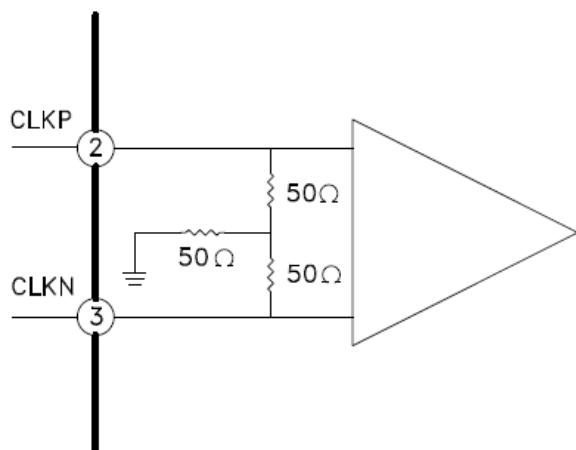

Figure 5 DC coupled CMOS Interface

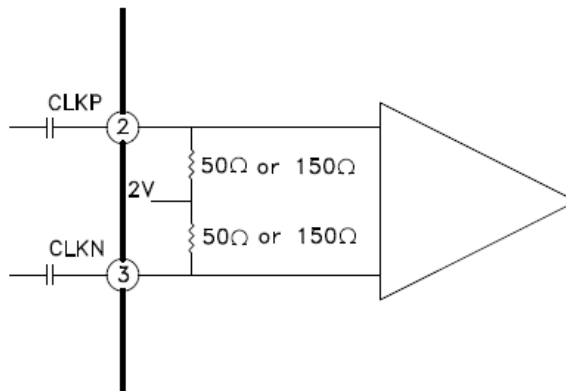

Figure 6 DC Coupled LVPECL Interface

Figure 7 AC Coupled Differential CML / LVPECL / LVDS / CMOS Interface

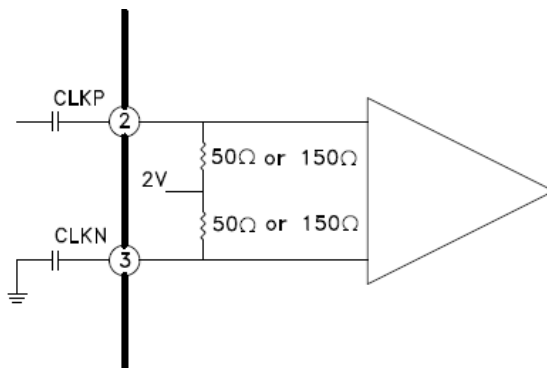

Figure 8 AC Coupled Single-Ended CML / LVPECL / LVDS / CMOS Interface

LVPECL OUTPUT STAGE

The LVPECL output driver produces up to 1.6 Vppd swing into 100 Ω differential loads. LVPECL drivers are terminated with off-chip resistors that provide the DC current through the emitter-follower output stage. The output stage has a switch which disconnects the output driver from the load when not used. The switch series resistor significantly improves the output match when driving into 50 Ω transmission lines. The switch series resistor causes a small DC level shift and swing degradation, depending on the termination current. If unused, disabled LVPECL outputs can be left floating, terminated, or grounded.

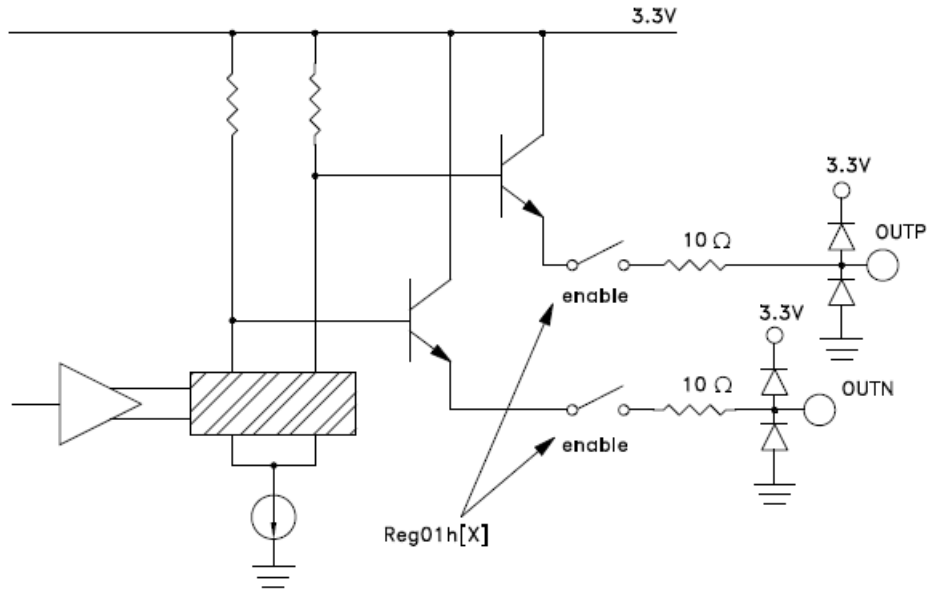

Figure 9 Output Stage

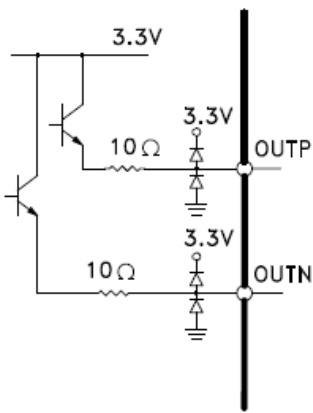

Figure 10 DC Coupled to LVPECL Interface

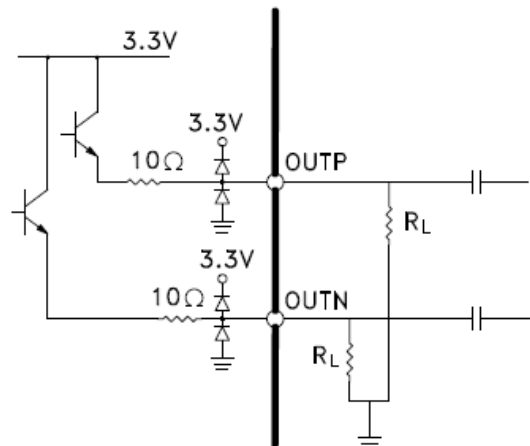

Figure 11 AC coupled to LVDS / CML / LVPECL / CMOS

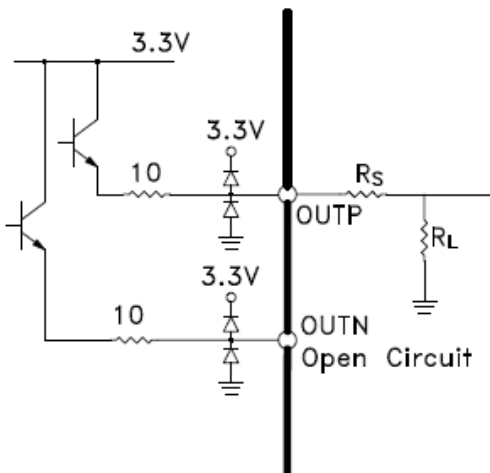

Figure 12 DC Coupled to CMOS Interface

The user has several choices in how they connect LVPECL drivers and receivers, and many resources that deal with this issue in detail. As a quick introduction, there are compromises between matching performance, common mode levels, and signal swing. For clocking applications, the user often has the luxury of using AC coupling, unlike in many data-path situations. Figure 12 shows a simplified interface schematic between an LVPECL output and input stage. Various options and trade-offs for the termination components are provided in Table III. The evaluation board allows flexibility in how the I/Os are configured, and allows the configuration in Figure 10, among many others.

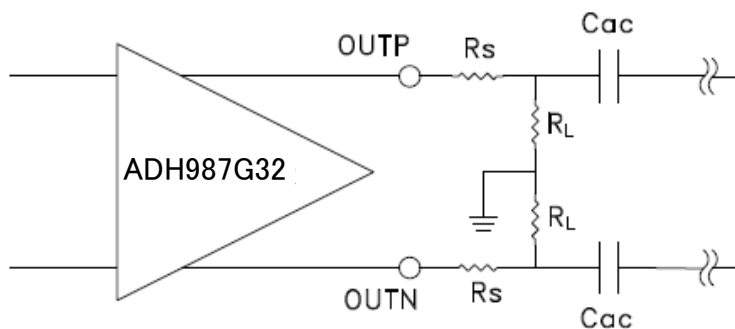

Figure 13 Recommended Interface Diagram

TABLE III. INTERFACE VALUES

Rs - Used to increase Ro to match to 50Ω environment already has - 10Ω internally	
0Ω	EVB: Largest signal swing, lowest common mode shift
10Ω	Better S22
RL - DC current termination for LVPECL output stage	
120Ω	EVB default: Standard LVPECL termination voltages
200Ω	Reduced current, no performance degradation
300Ω	Further reduced current, lower output power but flatter frequency response
OPEN	If using internal DC termination network at the Rx
Cac- AC coupling cap	
BG CAP	EVB default: If using AC coupling
SHORT	If using internal DC termination network at the Rx

RF OUTPUT STAGE

The RF output buffer is a CML output stage with 50 Ω impedance (single-ended) and adjustable power. In parallel mode (the PMODE_SEL pin = 1), it is at max gain (~ +3 dBm single-ended), whereas under SPI control, the gain can be lowered in ~3 dB steps down to -9 dBm single-ended. See Reg 0x04 for more information.

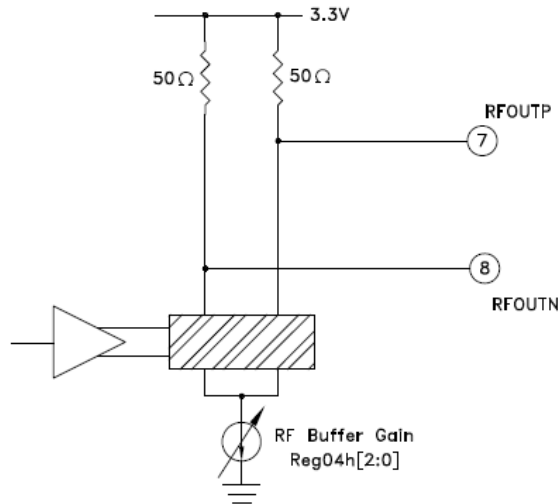

Figure 14 Output Stage

SERIAL PORT INTERFACE (SPI) CONTROL

The ADH987G32 can be controlled via SPI or parallel port control (for more information on parallel control see “Parallel Port Control”). SPI control offers more flexibility than parallel port control. The external pin PMODE-SEL = 1 configures the for parallel port operation, while PMODE-SEL = 0 enables SPI control.

The SPI control must be used to re-configure the input bias network from its default state (Reg03h), to adjust the output power control on the RF/CML buffer, and to individually enable arbitrary LVPECL outputs.

OPERATIONAL MODES

Serial Port Interface features:

- a. Compatibility with general serial port protocols that use a shift and strobe approach to communication.
- b. Compatible with multi-Chip solutions, useful to address multiple chips of various types from a single serial port bus.

SERIAL PORT WRITE OPERATION

TABLE IV. SPI OPEN MODE- WRITE TIMING CHARACTERISTICS

Parameter	Conditions	Min	Typ	Max	Units
t1	SDI setup time	3			ns
t2	SDI hold time	3			ns
t3	SEN low duration	10			ns
t4	SEN high duration	10			ns
t5	SCLK 9 Rising Edge to SEN Rising Edge	10			ns
	Serial port Clock Speed	DC	50		MHZ
t6	SEN to SCLK Recovery Time	10			ns

A typical WRITE cycle is shown in Figure 14.

- a. The Master (host) places 9 bit data, d8:d0, MSB first, on SDI on the first 9 falling edges of SCLK.
- b. The slave shifts in data on SDI on the first 9 rising edges of SCLK
- c. Master places 4 bit register address to be written to, r3:r0, MSB first, on the next 4 falling edges of SCLK (10-13)
- d. Slave shifts the register address bits on the next 4 rising edges of SCLK (10-13).
- e. Master places 3 bit chip address, a2:a0, MSB first, on the next 3 falling edges of SCLK (14-16). The chip address is fixed at 001.
- f. Slave shifts the chip address bits on the 3 rising edges of SCLK (14-16).
- g. Master asserts SEN after the 16th rising edge of SCLK.
- h. Slave registers the SDI data on the rising edge of SEN.

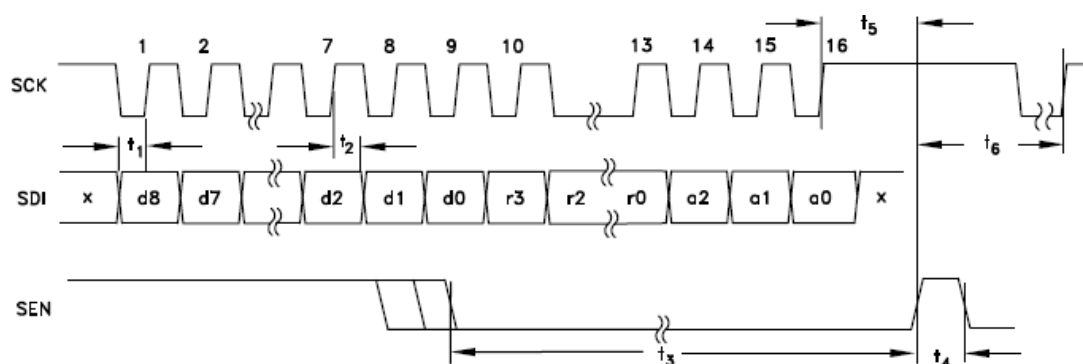

Figure 15 SPI Timing Diagram, Write Operation

SERIAL PORT READ OPERATION

To ensure correct read operation a pull-down resistor to ground ($\sim 1\text{-}2\text{k}\Omega$) is recommended on the Serial Data Out (SDO) line. A typical READ cycle is shown in Figure 15.

In general, SDO line is always active during the WRITE cycle. SDO contains the data from the addresses pointed to by Reg 0x00. If Reg 0x00 is not changed, the same data is always present on the SDO. If it is desired to READ from a specific address, it is necessary to write the desired address to Reg 0x00 in the first write cycle, then in the next SPI cycle, the desired data is on SDO pin.

An example of the two-cycle procedure to read from any random address is as follows:

The Master (host), on the first 9 falling edges of SCLK places 9 bit data, d8:d0, MSB first, on SDI as shown in Figure 15 d8:d4 should be set to zero. d3:d0 = address of the register to be READ on the next cycle.

- a. The slave () shifts in data on SDI on the first 9 rising edges of SCLK
- b. Master places 4 bit register address, r3:r0, (the address the WRITE ADDRESS register), MSB first, on the next 4 falling edges of SCLK (10-13). r3:r0=0000.
- c. Slave shifts the register bits on the next 4 rising edges of SCLK (10-13).
- d. Master places 3 bit chip address, a2:a0, MSB first, on the next 3 falling edges of SCLK (14-16). The chip address is fixed at 001.
- e. Slave shifts the chip address bits on the next 3 rising edges of SCLK (14-16).
- f. Master asserts SEN after the 16th rising edge of SCLK.
- g. Slave registers the SDI data on the rising edge of SEN.
- h. Master clears SEN to complete the address transfer of the two part READ cycle.
- i. If writing data to the chip at the same time as we do the second cycle is not wanted, then it is recommended to simply rewrite the same contents on SDI to Register zero on the READ back part of the cycle.
- j. Master places the same SDI data as the previous cycle on the next 16 falling edges of SCLK .
- k. Slave () shifts the SDI data on the next 16 rising edges of SCLK .
- l. Slave places the desired data (i.e. data from address in Reg00h[3:0]) on SDO on the next 16 rising edges of SCLK.
- m. Master asserts SEN after the 16th rising edge of SCLK to complete the cycle.

Note that if the chip address bits are unrecognized (a2:a0), the slave will tri-state the SDO output to prevent a possible bus contention issue.

TABLE V. SPI OPEN MODE - READ TIMING CHARACTERISTICS

Parameter	Conditions	Min	Typ	Max	Units
t1	SDI setup time	3			ns
t2	SDI hold time	3			ns
t3	SEN low duration	10			ns
t4	SEN high duration	10			ns
t5	SCLK Rising Edge to SDO time		8.2+0.2ns/pF		ns
t6	SEN to SCLK Recovery Time	10			ns
t7	SCLK 16 Rising Edge to SEN Rising Edge	10			ns

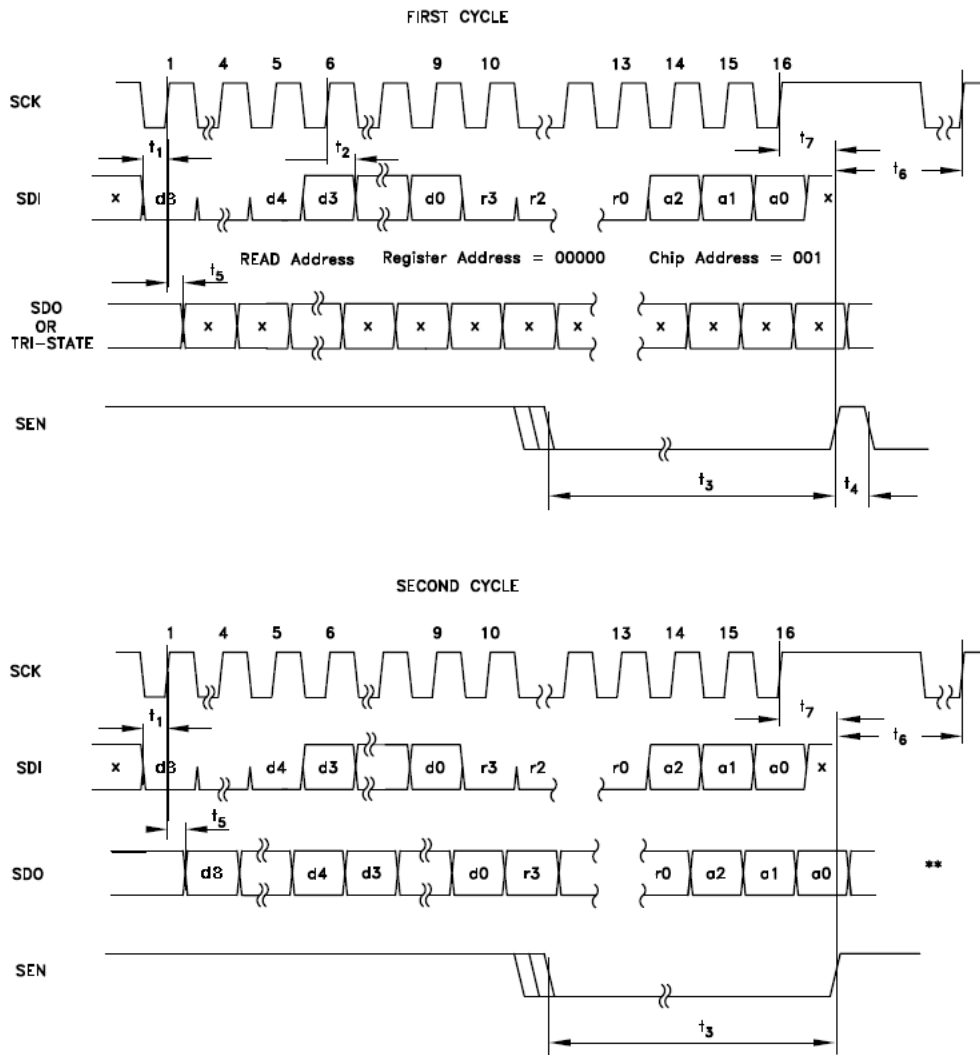

Figure 16 SPI Diagram, Read Operation 2- Cycles

ADH987S

REGISTER MAP

TABLE VI. REG 0x00 ID READ REGISTER

Bit	Name	Width	Default	Description
[3:0]	Read Control	4		Enter Register Address to be Read From
[4]	Soft Reset	1	0	1: Reset, Registers are set to the Default Condition
[8:0]	Chip ID	9	0x197	Reading register 00 will return the Chip ID, 0x197

TABLE VII. REG 0x01 MASTER ENABLE

Bit	Name	Width	Default	Description
[0]	Master Chip Enable	1	1	1= Active, 0=Power Down

TABLE VIII. REG 0x02 INDIVIDUAL ENABLES

Bit	Name	Width	Default	Description
[0]	en1	1	1	Enable Buffer 1
[1]	en2	1	1	Enable Buffer 2
[2]	en3	1	1	Enable Buffer 3
[3]	en4	1	1	Enable Buffer 4
[4]	en5	1	1	Enable Buffer 5
[5]	en6	1	1	Enable Buffer 6
[6]	en7	1	1	Enable Buffer 7
[7]	en8	1	1	Enable Buffer 8

TABLE IX. REG 0x03 RX BUFFER CONFIGURATION

Bit	Name	Width	Default	Description
[0]		1	0	Reserved 0
[1]	DC Internal	1	1	Use internal DC bias string
[2]	DC LVPECL	1	0	Use internal LVPECL Rx termination
[3]	Zin 50	1	1	Input termination select 1 - 50 Ω single-ended, 100 Ω differential 0 - 150 Ω single-ended, 300 Ω differential
[4]	RFBUF XOR	1	0	Toggle (XOR with RFBUFEN pin) the internal RF Buffer on/off
[8:5]		4	0	Reserved 0

TABLE X. REG 0x04 GAIN SELECT

Bit	Name	Width	Default	Description
[2:0]	RF Buffer Gain	3	7	0: Disabled 1: -9 dBm single-ended 2: -6 dBm single-ended 3: -3 dBm single-ended 4: 0 dBm single-ended >4: 3 dBm single-ended

TABLE XI. REG 0x05 BIASES

Bit	Name	Width	Default	Description
[1:0]	Reserved	2	2	Reserved - 2
[3:2]	Reserved	2	2	Reserved - 2
[5:4]	Reserved	2	3	Reserved - 3
[8:6]	Reserved	3	0	Reserved - 0

8.0 Package Outline Dimensions

The G32 package and outline dimensions can be found at <http://www.analog.com> or upon request.

ORDERING GUIDE

Model	Temperature Range	Package Description	Package Option
ADH987R701G32	-40°C to +85°C	32 Lead Glass/Metal Hermetic SMT	G32(FR-32-1)

Revision History		
Rev	Description of Change	Date
A	Initial Release	7/31/2019
B	Delete ADH987L701G32 and add ADH987R701G32. Remove Table IIA Group E Subgroup 4.	4/8/2021