

PART NUMBER	REVISION	DESCRIPTION	FEED TYPE
2151499-2	G	FINE CRIMP HEIGHT ADJUST	PNEUMATIC
5-2151499-2	G	SEAL STRIPPER CRIMPER TERMINATING UNIT	PNEUMATIC
7-2151499-2	G	PNEUMATIC AND CRIMP TOOLING KIT	PNEUMATIC
7-2151499-7	G	CRIMP TOOLING KIT	-

ATLANTIC VERSION TERMINATOR INTERFACE ADAPTER

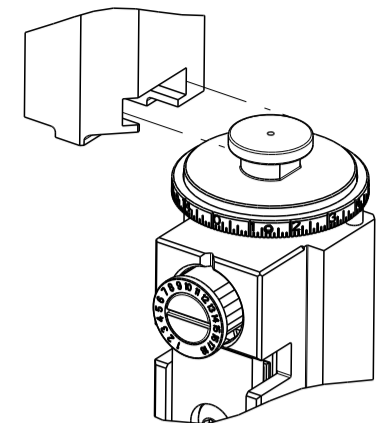

APPLICATOR DATA		
CRIMP	SIZE	TYPE
WIRE	2.39 mm [.094]	F
INSUL	4.32 mm [.170]	O

APPLICATOR INSTRUCTIONS 408-35042

TERMINAL DATA: DELPHI TERMINAL		DELPHI PACKARD CRIMP SPECIFICATION	
TERMINAL NAME: TAXI TERMINAL W/P I-PIN			
WIRE STRIP LENGTH	INSULATION DIAMETER RANGE		
4.83-5.59 mm [1.90-.220 IN]	Ø 1.6-2.2 [1.063-.087 IN]		
TERMINAL APPLICATION SPECIFICATION 12089040 PAGE 5 OF 40 Rev 2013-10-30			

TERMINAL DATA: DELPHI TERMINAL		DELPHI PACKARD CRIMP SPECIFICATION	
TERMINAL NAME: TAXI TERMINAL W/P I-PIN			
WIRE STRIP LENGTH	INSULATION DIAMETER RANGE		
4.83-5.59 mm [1.90-.220 IN]	Ø 1.6-2.45 [1.063-.096 IN]		
TERMINAL APPLICATION SPECIFICATION 12146501 PAGE 1 & 2 OF 3 Rev 2013-10-29			

TE TERMINAL	DELPHI TERMINAL	TE SEAL	DELPHI SEAL	CABLE DIAMETER
286550-1	12089040	1949092-1	15324985	Ø 1.6-2.15
		1949092-2	15324982	Ø 2.03-2.85
		1949772-2	12034365	Ø 1.29-1.7
		1949772-1	15324983	Ø 1.29-1.7
		286553-1	12015323	Ø 2.03-2.85

TE TERMINAL	DELPHI TERMINAL	TE SEAL	DELPHI SEAL	CABLE DIAMETER
286550-2	12146501	1949092-1	15324985	Ø 1.6-2.15
		1949092-2	15324982	Ø 2.03-2.85
		1949772-2	12034365	Ø 1.29-1.7
		1949772-1	15324983	Ø 1.29-1.7
		286553-1	12015323	Ø 2.03-2.85

WIRE SIZE	CRIMP HEIGHT mm [INCH]	CRIMP HEIGHT REFERENCE SETTING
16 AWG OR 1.25mm2	1.30+/-0.05 [1.051+/-0.002]	6.8
0.80mm2	1.15+/-0.05 [1.045+/-0.002]	8.3
0.50mm2	1.10+/-0.05 [1.043+/-0.002]	8.9

WIRE SIZE	CRIMP HEIGHT mm [INCH]	CRIMP HEIGHT REFERENCE SETTING
0.80mm2	1.10+/-0.05 [1.043+/-0.002]	8.9
0.50mm2	1.05+/-0.05 [1.041+/-0.002]	9.5

- 1 RECOMMENDED SPARE PARTS
- 2 REFER TO SUPPLIED INSTRUCTION SHEET FOR CLEANING, LUBRICATION & STORAGE OF APPLICATOR.
- 3 APPLY PART NUMBER 1-23419-5 LOCTITE TO THREADS OF ITEM 180. APPLY PART NUMBER 2-23419-6 LOCTITE TO THREADS OF ITEM 242.
- 4 CRIMP HEIGHT REFERENCE SETTING WAS THE SETTING USED WHEN THE APPLICATOR WAS QUALIFIED AT THE FACTORY. ADJUSTMENT MAY BE NECESSARY WHEN RUNNING APPLICATOR IN THE FIELD.
- 5 TERMINAL PITCH NOT COMPATIBLE WITH MECHANICAL FEED.
- 6 APPLY TORQ-SEAL IN ALLEN SOCKET TO FILL HOLE AFTER FLAT HD HAS BEEN ADJUSTED TO CORRECT HEIGHT AT QUALIFICATION. APPLY #1-23419-5 LOC-TITE TO THREADS.
- 7 ITEM 24 (STRIP GUIDE) WILL NEED ADJUSTED WHEN RUNNING DIFFERENT TERMINALS.
- 8. UNLESS SPECIFIED OTHERWISE TORQUE VALUES SHALL BE USED PER DOCUMENT, 101-35000.

TERMINAL DATA: DELPHI PACKARD TERMINAL		DELPHI PACKARD CRIMP SPECIFICATION	
TERMINAL NAME: TAXI TERMINAL W/P - SOCKET			
WIRE STRIP LENGTH	INSULATION DIAMETER RANGE		
4.82-5.58 mm [1.90-.220 IN]	Ø 1.6-2.45 [1.063-.096 IN]		
TERMINAL APPLICATION SPECIFICATION 12089188 PAGE 5 & 8 OF 35 Rev 2014-03-04			

TE TERMINAL	DELPHI TERMINAL	TE SEAL	DELPHI SEAL	CABLE DIAMETER
286551-1	12089188	1949092-1	15324985	Ø 1.6-2.15
		1949092-2	15324982	Ø 2.03-2.85
		1949772-2	12034365	Ø 1.29-1.7
		1949772-1	15324983	Ø 1.29-1.7
		286553-1	12015323	Ø 2.03-2.85

WIRE SIZE	CRIMP HEIGHT mm [INCH]	CRIMP HEIGHT REFERENCE SETTING
0.80mm2	1.15+/-0.05 [1.045+/-0.002]	8.3
0.50mm2	1.10+/-0.05 [1.043+/-0.002]	8.9

9 THIS CRIMP PARAMETER IS PROVIDED TO MEET A CUSTOM AND UNIQUE CUSTOMER REQUIREMENT. IT HAS BEEN EVALUATED AND IS CONDITIONALLY SPECIFIED BY TE CONNECTIVITY. THIS CUSTOMIZED CRIMP PARAMETER IS NOT LISTED AS AN APPROVED APPLICATION WITHIN THE TERMINAL MANUFACTURER'S SPECIFICATIONS. **TE CONNECTIVITY EXPRESSLY DISCLAIMS ANY AND ALL WARRANTIES THAT THE PRODUCT WILL PERFORM SIMILARLY TO VALIDATED AND APPROVED APPLICATIONS, AS STATED WITHIN THE MANUFACTURER'S APPLICATION SPECIFICATIONS, INCLUDING BUT NOT LIMITED TO IMPLIED WARRANTIES OF MERCHANTABILITY OR FITNESS FOR PARTICULAR PURPOSE.** AS SUCH, IT IS HIGHLY RECOMMENDED THAT THE CUSTOMER PERFORM FURTHER DETAILED EVALUATION TO ASSESS PRODUCT PERFORMANCE IN THE SPECIFIC APPLICATION AND OBTAIN APPROVAL FROM TERMINAL MANUFACTURER FOR THIS CUSTOM REQUIREMENT.

**\*WARNING**  
ON INSTALLATION, SET WIRE DISC TO CRIMP HEIGHT REFERENCE SETTING FOR LARGEST WIRE SIZE. CRIMP HEIGHT REFERENCE SETTINGS GREATER THAN THE VALUE SHOWN MAY CAUSE DAMAGE TO THE CRIMP TOOLING, REFER TO THE INSTRUCTION SHEET FOR PROPER SETUP AND ADJUSTMENTS.

ATLANTIC VERSION  
Shown on sheets 1 of 4 & 2 of 4  
(Pacific version shown on sheets 3 of 4 & 4 of 4)

LOC	DIST	REVISIONS					
A	66	P	LTN	DESCRIPTION	DATE	OWN	APVD
		E		ECR-19-001536	29JAN2019	MEH	TE
		F		ECR-19-005396	03APR2019	LG	TE
		G		ECR-20-011484	13AUG2020	JWC	TE
		G1		ECR-21-007085	29JUL2021	JWC	TE

-	-	1	-	1803515-3	RAM ASSEMBLY, SF ATLANTIC	293	
-	-	1	-	2-1803583-1	APPLICATOR BASIC ASSEMBLY, SF	292	
-	1	1	1	2119641-1	FEED CAM, AIR FEED	248	
-	1	1	1	2119082-6	CAM, SNAIL, INSULATION ADJUSTMENT	244	
-	1	1	1	2079764-1	WASHER, WAVE SPRING, CREST-TO-CREST	243	
3	-	1	1	2119083-1	RETAINER, INSULATION DIAL	242	
-	1	1	1	7-18023-7	SCR, SKT HD CAP M3 X 4.0	241	
-	1	1	1	2844940-1	AIR FEED MODULE	238	
-	-	1	-	4-1722335-3	STRIPPER, SIDE FEED	182	
-	-	1	-	1-5018030-0	NUT, HEX, REG, RoHS, M3.5	181	
3	-	-	1	1-1752354-9	STANDOFF, HOLD-DOWN	180	
-	-	1	-	993111-1	PIN, SLOTTED SPRING 3.0 X 20.0	177	
-	-	1	-	5-22280-0	SPRING, COMPRESSION	176	
-	-	1	-	1752353-3	GUIDE PIN, HOLDDOWN	175	
-	-	1	-	1901680-2	GUIDE PIN, HOLDDOWN	174	
-	REF	REF	REF	994970-2	COUNTER, MAGNETIC	164	
-	1	1	1	2844908-1	SCREW, LOCKING	99	
-	1	1	1	2844907-1	POST, LOCKING	98	
-	1	1	1	455888-7	SPACER, CRIMPER	82	
-	1	1	1	1803607-3	DOCUMENTATION PACKAGE	71	
-	1	1	1	2119740-1	TAG, IDENTIFICATION	67	
-	2	2	2	2168078-1	SCREW, DRIVE, RH, RoHS, 2 x .188	66	
-	1	1	1	2168083-2	SCR, SKT HD CAP, RoHS, M4 X 8.0	60	
-	1	1	1	5-18022-5	SCR, HEX HD CAP, M4 X 6.0	59	
6	-	1	1	985575-3	SCR, FLT SKT HD CAP M3 X 10.0	57	
-	1	1	1	1338685-1	PAWL, FEED	56	
-	4	4	4	2168083-3	SCR, SKT HD CAP, RoHS, M4 X 12.0	54	
-	2	2	2	2168083-3	SCR, SKT HD CAP, RoHS, M4 X 12.0	53	
-	1	1	1	1803382-6	HOLD DOWN, SPRING LOADED	50	
-	1	1	1	18023-9	SCR, SKT HD CAP M4 X 6.0	49	
-	1	-	1	1803583-9	APPLICATOR BASIC ASSEMBLY, SF	46	
-	1	-	1	1803515-1	RAM ASSEMBLY, SF ATLANTIC	44	
-	1	1	1	1803602-1	SCR, BHSC, RoHS (M8 X 25)	41	
-	1	1	1	1752356-1	SUPPORT, TERMINAL	34	
-	2	2	2	2079383-5	SCR, BHSC, RoHS (M4 X 20)	33	
-	2	2	2	3-2844962-0	SPACER, CYLINDRICAL, STRIP GUIDE	30	
-	1	1	1	2844992-1	ASSEMBLY, STRIP GUIDE	29	
-	1	1	1	455888-3	SPACER, CRIMPER	28	
7	-	1	1	1320928-6	STRIP GUIDE	24	
-	1	-	1	2168083-2	SCR, SKT HD CAP, RoHS, M4 X 8.0	21	
-	2	1	2	1-18028-2	WASHER, FLAT, REG M4	20	
-	1	-	1	2119533-1	STRIPPER, SIDE FEED	19	
7	-	1	1	1	2119806-1	INSERT, SHEAR	13
-	1	1	1	3-22280-3	SPRING, COMPRESSION	12	
-	1	1	1	1-356885-4	STOP, SHEAR	11	
7	-	1	1	1	2119805-1	SHEAR HOLDER, FRONT	10
7	-	1	1	1	318707-1	FLOATING SHEAR, FRONT	9
7	1	2	1	1	5-1633620-9	ANVIL, COMBINATION	8
-	1	1	1	3-240641-3	SPACER	7	
-	-	-	-	-	-	6	
-	1	1	1	2119781-1	DEPRESSOR, SHEAR	5	
-	1	1	1	5-238011-7	BLOCK, CRIMPER SPACER	4	
7	1	2	1	1	4-1633966-9	CRIMPER, INSULATION O	3
-	1	1	1	455888-3	SPACER, CRIMPER	2	
7	1	2	1	1	4-1490019-1	CRIMPER, WIRE PREMIUM	1

DIMENSIONS:		TOLERANCES UNLESS OTHERWISE SPECIFIED:		OWN	CHK	DATE	TE Connectivity	
mm	0 PLC ±	1 PLC ±	2 PLC ±	C. MOYER	T. ELBIN	10JAN2012	Harrisburg, PA 17105-3608	
	3 PLC ±	4 PLC ±	ANGLES ±	T. ELBIN	T. ELBIN	10JAN2012	NAME Ocean Side Feed Applicator	
MATERIAL	FINISH	WEIGHT	SCALE	Customer Accessible Production Drawing		1:2	SHEET 1 of 4	REV G1

LOC	DIST	REVISIONS			
P	LTN	DESCRIPTION	DATE	DMN	APVD
A	66	SEE SHEET 1	-	-	-

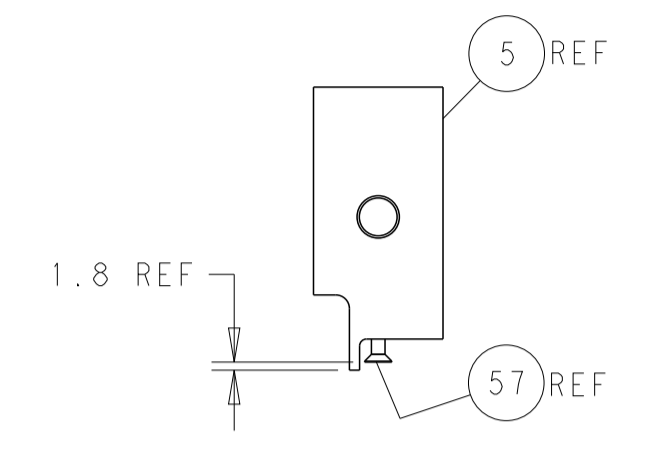
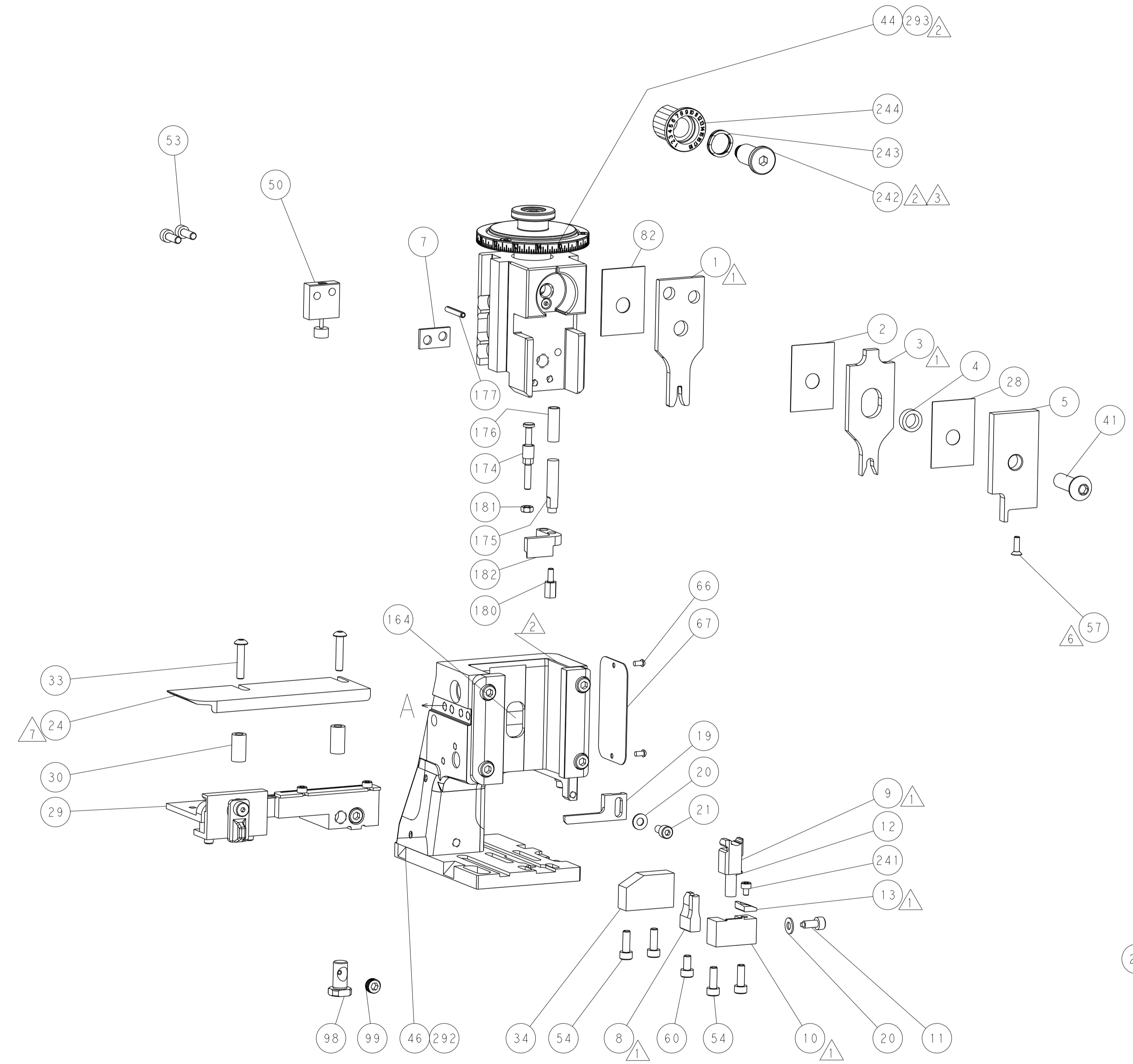
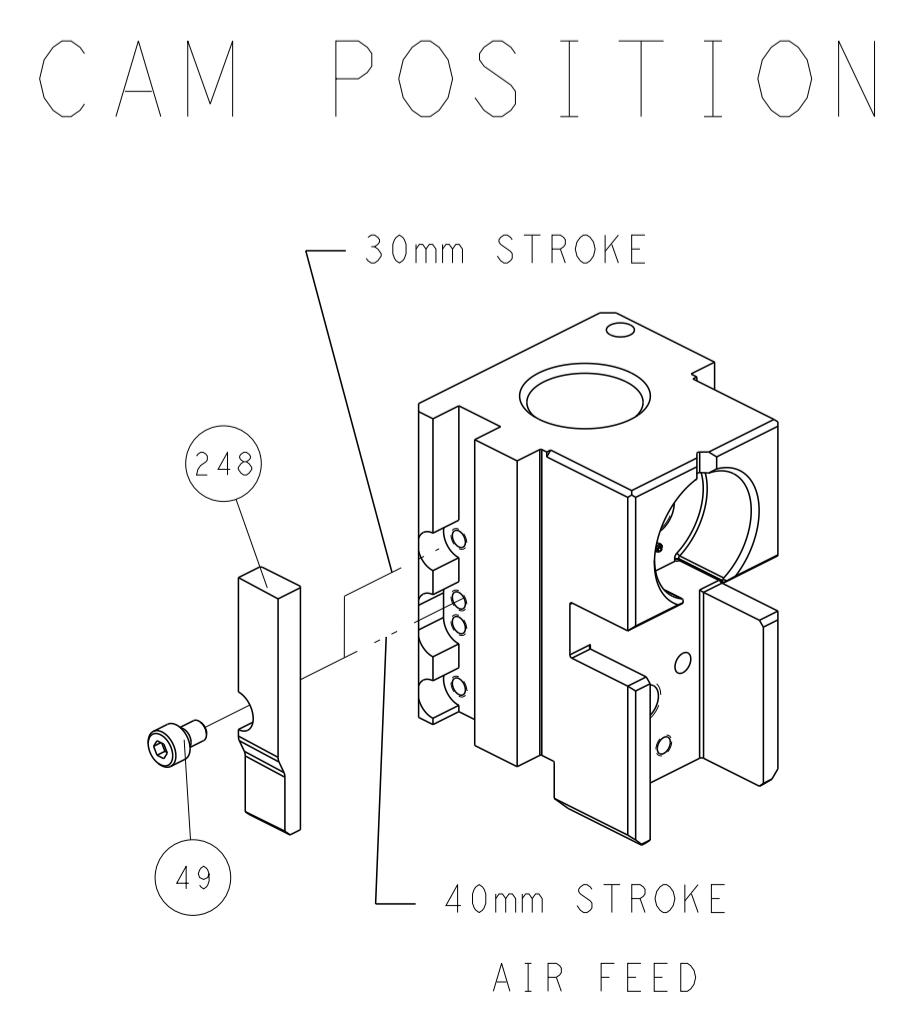
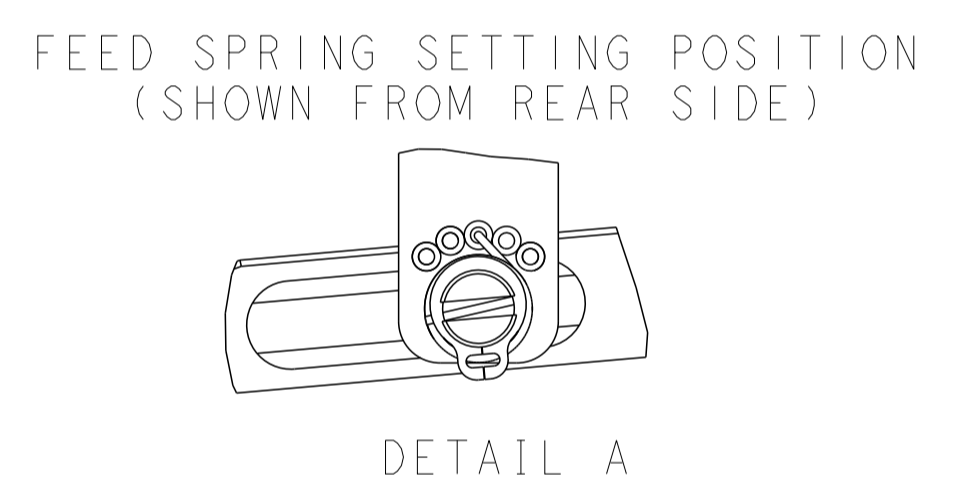
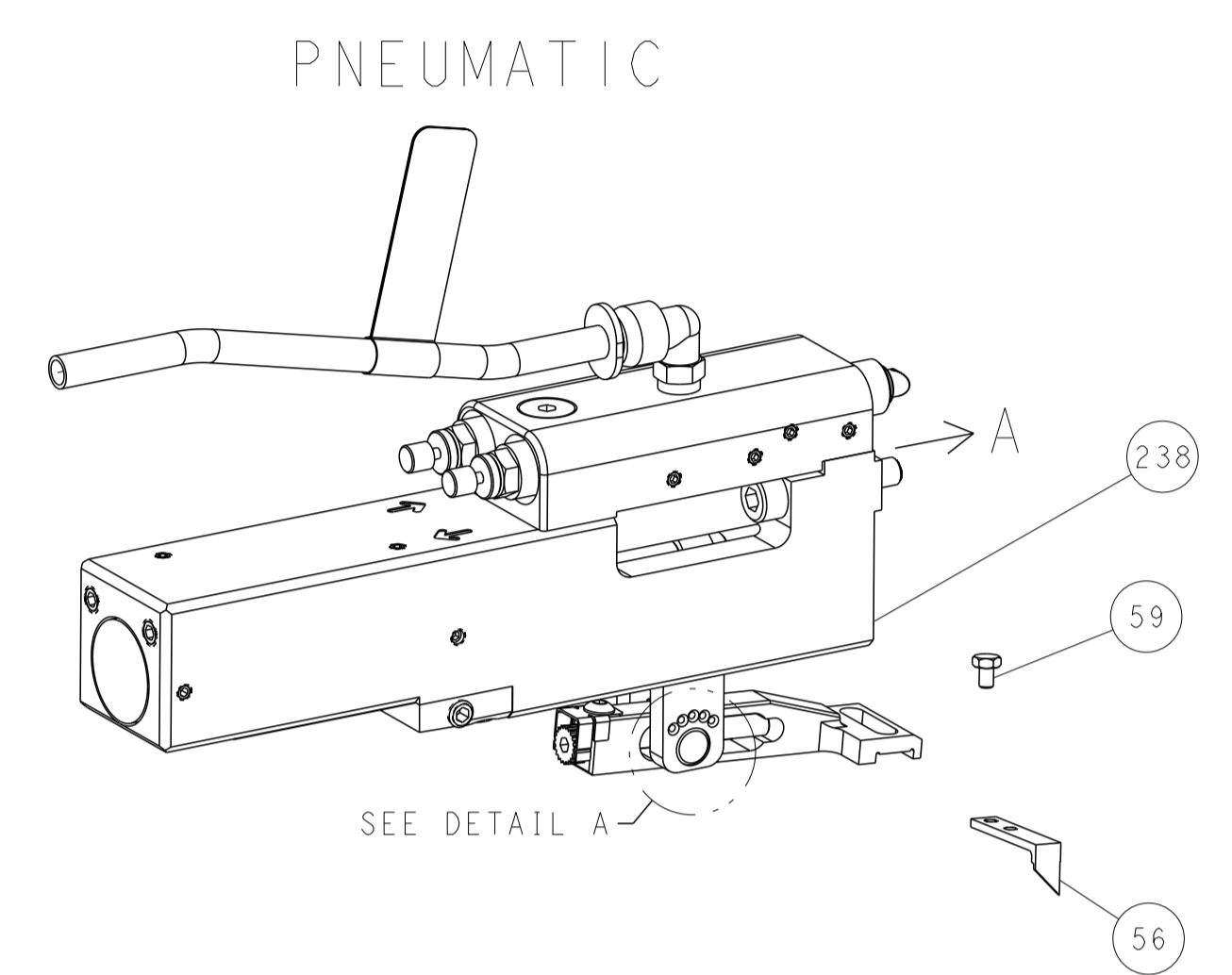

SHEAR DEPRESSOR DETAIL

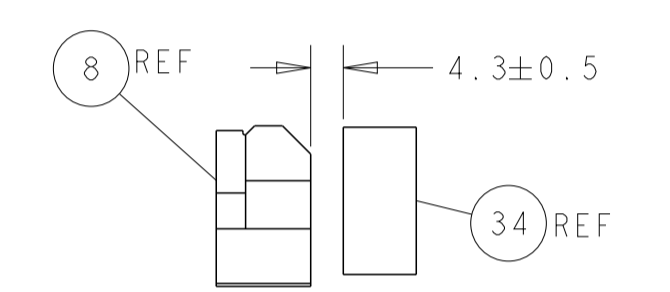

TERMINAL SUPPORT LOCATION

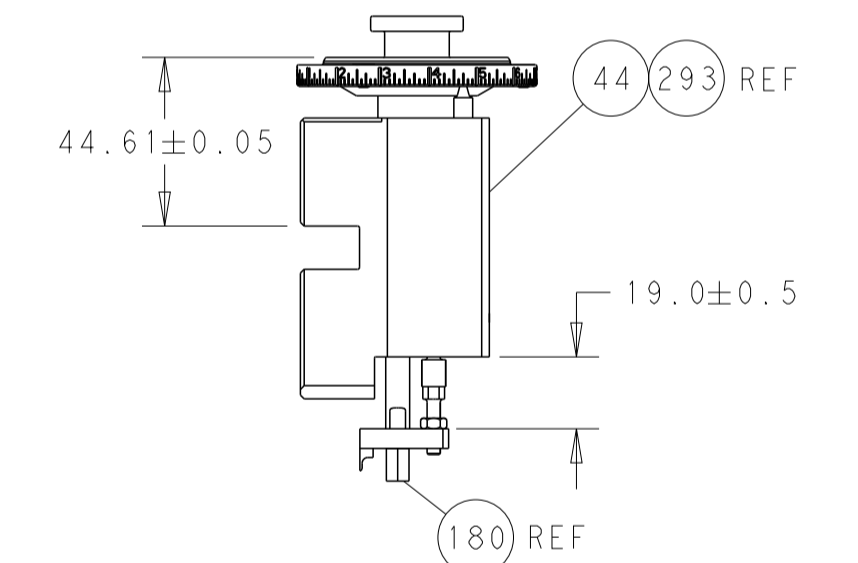

RAM AND HOLD DOWN SET-UP

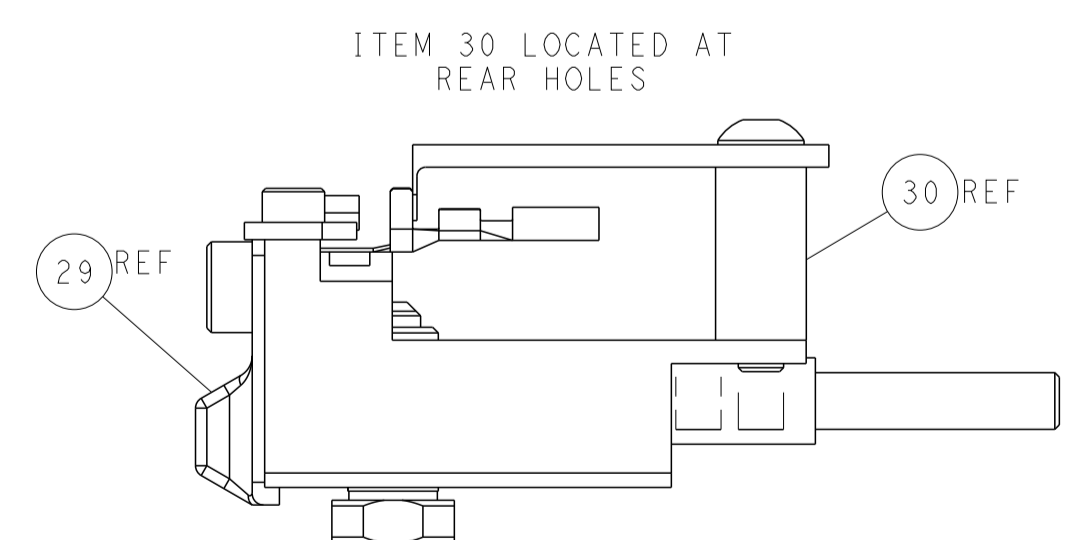

FEED TRACK POSITION GUIDE BY INSULATION BARREL

ATLANTIC VERSION  
 Shown on sheets 1 of 4 & 2 of 4  
 (Pacific version shown on sheets 3 of 4 & 4 of 4)

<small>THIS DRAWING IS UNPUBLISHED. RELEASED FOR PUBLICATION. ALL RIGHTS RESERVED. THIS DRAWING IS CONTROLLED DOCUMENT. THE INFORMATION CONTAINED HEREIN IS UNCLASSIFIED EXCEPT WHERE SHOWN OTHERWISE. THIS INFORMATION IS UNCLASSIFIED EXCEPT WHERE SHOWN OTHERWISE.</small>		DWN C. MOYER 10JAN2012 CHK T. ELBIN 10JAN2012 APVD T. ELBIN 10JAN2012	TE Connectivity Harrisburg, PA 17105-3608
DIMENSIONS: mm TOLERANCES UNLESS OTHERWISE SPECIFIED: 0 PLC ± 1 PLC ± 2 PLC ± 3 PLC ± 4 PLC ± ANGLES ± MATERIAL: - FINISH: -		NAME: Ocean Side Feed Applicator PRODUCT SPEC: - APPLICATION SPEC: - SIZE: A1 CAGE CODE: 00779 DRAWING NO: 2151499 WEIGHT: - SCALE: 1:2 SHEET: 2 of 4 REV: G1	RESTRICTED TO: - Customer Accessible Production Drawing

PART NUMBER	REVISION	DESCRIPTION	FEED TYPE
2-2151499-2	G	FINE CRIMP HEIGHT ADJUST	PNEUMATIC
7-2151499-7	G	CRIMP TOOLING KIT	-

PACIFIC VERSION TERMINATOR  
 INTERFACE ADAPTER

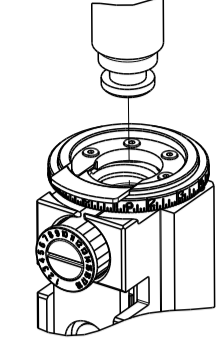

APPLICATOR DATA		
CRIMP	SIZE	TYPE
WIRE	2.39 mm [.094]	F
INSUL	4.32 mm [.170]	O
APPLICATOR INSTRUCTIONS 408-35042		

TERMINAL DATA: DELPHI TERMINAL DELPHI PACKARD CRIMP SPECIFICATION	
TERMINAL NAME: TAXI TERMINAL W/P I-PIN	
WIRE STRIP LENGTH 4.83-5.59 mm [1.90-.220 IN]	INSULATION DIAMETER RANGE Ø 1.6-2.2 [.063-.087 IN]
TERMINAL APPLICATION SPECIFICATION 12089040 PAGE 5 OF 40 Rev 2013-10-30	

TERMINALS APPLIED				
TE TERMINAL	DELPHI TERMINAL	TE SEAL	DELPHI SEAL	CABLE DIAMETER
286550-1	12089040	1949092-1	15324985	Ø 1.6-2.15
		1949092-2	15324982	Ø 2.03-2.85
		1949772-2	12034365	Ø 1.29-1.7
		1949772-1	15324983	Ø 1.29-1.7
		286553-1	12015323	Ø 2.03-2.85

WIRE SIZE	CRIMP HEIGHT mm [INCH]	CRIMP HEIGHT REFERENCE SETTING
16 AWG OR 1.25mm <sup>2</sup>	1.30+/-0.05 [.051+/- .002]	6.8
0.80mm <sup>2</sup>	1.15+/-0.05 [.045+/- .002]	8.3
0.50mm <sup>2</sup>	1.10+/-0.05 [.043+/- .002]	8.9

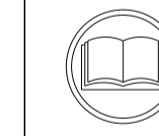

- RECOMMENDED SPARE PARTS
- REFER TO SUPPLIED INSTRUCTION SHEET FOR CLEANING, LUBRICATION & STORAGE OF APPLICATOR.
- APPLY PART NUMBER 2-23419-6 LOCTITE TO THREADS OF ITEM 242.
- CRIMP HEIGHT REFERENCE SETTING WAS THE SETTING USED WHEN THE APPLICATOR WAS QUALIFIED AT THE FACTORY. ADJUSTMENT MAY BE NECESSARY WHEN RUNNING APPLICATOR IN THE FIELD.
- TERMINAL PITCH NOT COMPATIBLE WITH MECHANICAL FEED.
- APPLY TORQ-SEAL IN ALLEN SOCKET TO FILL HOLE AFTER FLAT HD HAS BEEN ADJUSTED TO CORRECT HEIGHT AT QUALIFICATION. APPLY #1-23419-5 LOC-TITE TO THREADS.
- ITEM 24 (STRIP GUIDE) WILL NEED ADJUSTED WHEN RUNNING DIFFERENT TERMINALS.
- UNLESS SPECIFIED OTHERWISE TORQUE VALUES SHALL BE USED PER DOCUMENT, 101-35000.
- THIS CRIMP PARAMETER IS PROVIDED TO MEET A CUSTOM AND UNIQUE CUSTOMER REQUIREMENT. IT HAS BEEN EVALUATED AND IS CONDITIONALLY SPECIFIED BY TE CONNECTIVITY. THIS CUSTOMIZED CRIMP PARAMETER IS NOT LISTED AS AN APPROVED APPLICATION WITHIN THE TERMINAL MANUFACTURER'S SPECIFICATIONS. **TE CONNECTIVITY EXPRESSLY DISCLAIMS ANY AND ALL WARRANTIES THAT THE PRODUCT WILL PERFORM SIMILARLY TO VALIDATED AND APPROVED APPLICATIONS, AS STATED WITHIN THE MANUFACTURER'S APPLICATION SPECIFICATIONS, INCLUDING BUT NOT LIMITED TO IMPLIED WARRANTIES OF MERCHANTABILITY OR FITNESS FOR PARTICULAR PURPOSE.** AS SUCH, IT IS HIGHLY RECOMMENDED THAT THE CUSTOMER PERFORM FURTHER DETAILED EVALUATION TO ASSESS PRODUCT PERFORMANCE IN THE SPECIFIC APPLICATION AND OBTAIN APPROVAL FROM TERMINAL MANUFACTURER FOR THIS CUSTOM REQUIREMENT.

TERMINAL DATA: DELPHI TERMINAL DELPHI PACKARD CRIMP SPECIFICATION	
TERMINAL NAME: TAXI TERMINAL W/P I-PIN	
WIRE STRIP LENGTH 4.83-5.59 mm [1.90-.220 IN]	INSULATION DIAMETER RANGE Ø 1.6-2.45 [.063-.096 IN]
TERMINAL APPLICATION SPECIFICATION 12146501 PAGE 1 & 2 OF 3 Rev 2013-10-29	

TERMINALS APPLIED				
TE TERMINAL	DELPHI TERMINAL	TE SEAL	DELPHI SEAL	CABLE DIAMETER
286550-2	12146501	1949092-1	15324985	Ø 1.6-2.15
		1949092-2	15324982	Ø 2.03-2.85
		1949772-2	12034365	Ø 1.29-1.7
		1949772-1	15324983	Ø 1.29-1.7
		286553-1	12015323	Ø 2.03-2.85

WIRE SIZE	CRIMP HEIGHT mm [INCH]	CRIMP HEIGHT REFERENCE SETTING
0.80mm <sup>2</sup>	1.10+/-0.05 [.043+/- .002]	8.9
0.50mm <sup>2</sup>	1.05+/-0.05 [.041+/- .002]	9.5

TERMINAL DATA: DELPHI PACKARD TERMINAL DELPHI PACKARD CRIMP SPECIFICATION	
TERMINAL NAME: TAXI TERMINAL W/P - SOCKET	
WIRE STRIP LENGTH 4.82-5.58 mm [1.90-.220 IN]	INSULATION DIAMETER RANGE Ø 1.6-2.45 [.063-.096 IN]
TERMINAL APPLICATION SPECIFICATION 12089188 PAGE 5 & 8 OF 35 Rev 2014-03-04	

TERMINALS APPLIED				
TE TERMINAL	DELPHI TERMINAL	TE SEAL	DELPHI SEAL	CABLE DIAMETER
286551-1	12089188	1949092-1	15324985	Ø 1.6-2.15
		1949092-2	15324982	Ø 2.03-2.85
		1949772-2	12034365	Ø 1.29-1.7
		1949772-1	15324983	Ø 1.29-1.7
		286553-1	12015323	Ø 2.03-2.85

WIRE SIZE	CRIMP HEIGHT mm [INCH]	CRIMP HEIGHT REFERENCE SETTING
0.80mm <sup>2</sup>	1.15+/-0.05 [.045+/- .002]	8.3
0.50mm <sup>2</sup>	1.10+/-0.05 [.043+/- .002]	8.9

**\*WARNING**  
 ON INSTALLATION, SET WIRE DISC TO CRIMP HEIGHT REFERENCE SETTING FOR LARGEST WIRE SIZE. CRIMP HEIGHT REFERENCE SETTINGS GREATER THAN THE VALUE SHOWN MAY CAUSE DAMAGE TO THE CRIMP TOOLING, REFER TO THE INSTRUCTION SHEET FOR PROPER SETUP AND ADJUSTMENTS.

PACIFIC VERSION  
 Shown on sheets 3 of 4 & 4 of 4  
 (Atlantic version shown on sheets 1 of 4 & 2 of 4)

LOC	DIST	REVISIONS			
A	66	P LTR	DESCRIPTION	DATE	OWN
		-	SEE SHEET 1	-	-

-	1	2119082-6	CAM, SNAIL, INSULATION ADJUSTMENT	244
-	1	2079764-1	WASHER, WAVE SPRING, CREST-TO-CREST	243
-	1	2119083-1	RETAINER, INSULATION DIAL	242
-	1	7-18023-7	SCR, SKT HD CAP M3 X 4.0	241
-	1	2844940-1	AIR FEED MODULE	238
-	REF	994970-2	COUNTER, MAGNETIC	164
-	1	2119641-2	FEED CAM, AIR FEED	151
-	1	2168083-8	SCR, SKT HD CAP, RoHS, M4 X 16	144
-	4	2168083-9	SCR, SKT HD CAP, RoHS, M4 X 20	143
-	1	1-1803583-0	APPLICATOR BASIC ASSEMBLY, SF	141
-	1	1803516-1	RAM ASSEMBLY, SF PACIFIC	140
-	1	2844908-1	SCREW, LOCKING	99
-	1	2844907-1	POST, LOCKING	98
-	1	455888-7	SPACER, CRIMPER	82
-	1	1803607-3	DOCUMENTATION PACKAGE	71
-	1	2119740-1	TAG, IDENTIFICATION	67
-	2	2168078-1	SCREW, DRIVE, RH, RoHS, 2 x .188	66
-	1	5-18022-5	SCR, HEX HD CAP, M4 X 6.0	59
-	1	985575-3	SCR, FLT SKT HD CAP M3 X 10.0	57
-	1	1338685-1	PAWL, FEED	56
-	2	2168083-3	SCR, SKT HD CAP, RoHS, M4 X 12.0	53
-	1	1803382-6	HOLD DOWN, SPRING LOADED	50
-	1	18023-9	SCR, SKT HD CAP M4 X 6.0	49
-	1	1803602-1	SCR, BHSC, RoHS (M8 X 25)	41
-	1	1752356-1	SUPPORT, TERMINAL	34
-	2	2079383-5	SCR, BHSC, RoHS (M4 X 20)	33
-	2	3-2844962-0	SPACER, CYLINDRICAL, STRIP GUIDE	30
-	1	2844992-1	ASSEMBLY, STRIP GUIDE	29
-	1	455888-3	SPACER, CRIMPER	28
-	1	1320928-6	STRIP GUIDE	24
-	1	2168083-2	SCR, SKT HD CAP, RoHS, M4 X 8.0	21
-	2	1-18028-2	WASHER, FLAT, REG M4	20
-	1	2119533-1	STRIPPER, SIDE FEED	19
-	1	2119806-1	INSERT, SHEAR	13
-	1	3-22280-3	SPRING, COMPRESSION	12
-	1	1-356885-4	STOP, SHEAR	11
-	1	2119805-1	SHEAR HOLDER, FRONT	10
-	1	318707-1	FLOATING SHEAR, FRONT	9
-	1	5-1633620-9	ANVIL, COMBINATION	8
-	1	3-240641-3	SPACER	7
-	-	-	-	6
-	1	2119781-1	DEPRESSOR, SHEAR	5
-	1	5-238011-7	BLOCK, CRIMPER SPACER	4
-	1	4-1633966-9	CRIMPER, INSULATION O	3
-	1	455888-3	SPACER, CRIMPER	2
-	1	4-1490019-1	CRIMPER, WIRE PREMIUM	1

DIMENSIONS:		TOLERANCES UNLESS OTHERWISE SPECIFIED:		MATERIAL:	
mm	0 PLC ±	1 PLC ±	2 PLC ±	3 PLC ±	4 PLC ±
	ANGLES	FINISH			

OWN	CHK	DATE	NAME	SIZE	CAGE CODE	DRAWING NO	RESTRICTED TO
C. MOYER	T. ELBIN	10JAN2012	Ocean Side Feed Applicator	A1	00779	2151499	-

Customer Accessible Production Drawing SCALE 1:2 SHEET 3 OF 4 REV G1

LOC	DIST	REVISIONS					
A	66	P	LTN	DESCRIPTION	DATE	DWN	APVD
		-		SEE SHEET 1	-	-	-

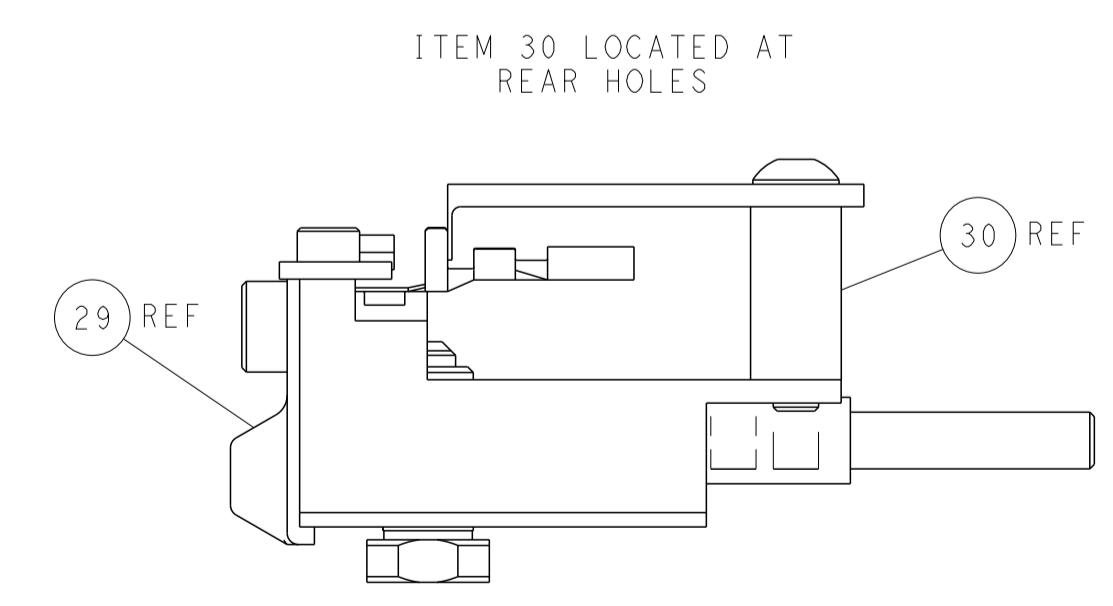
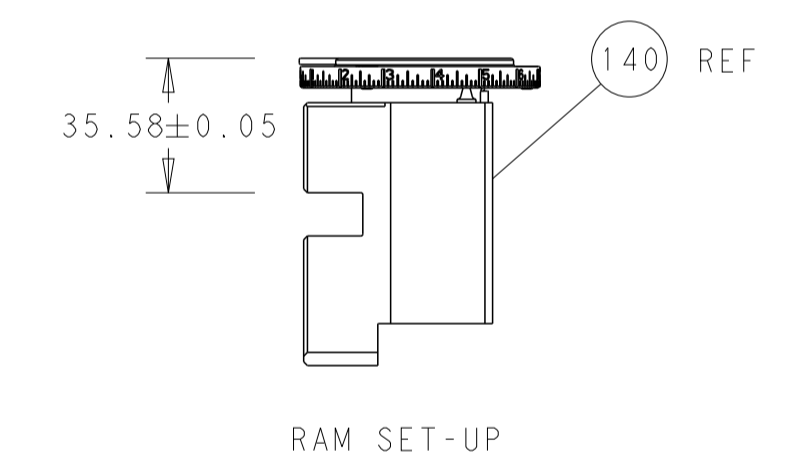
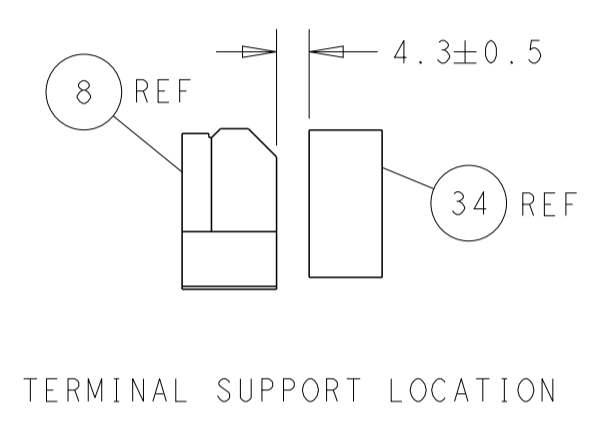
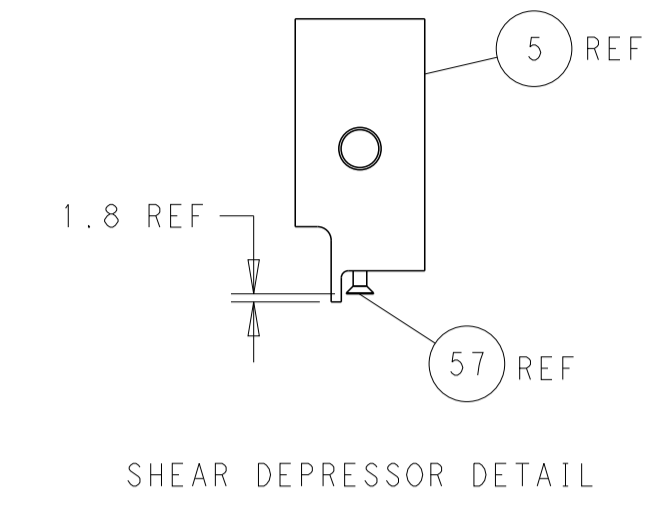
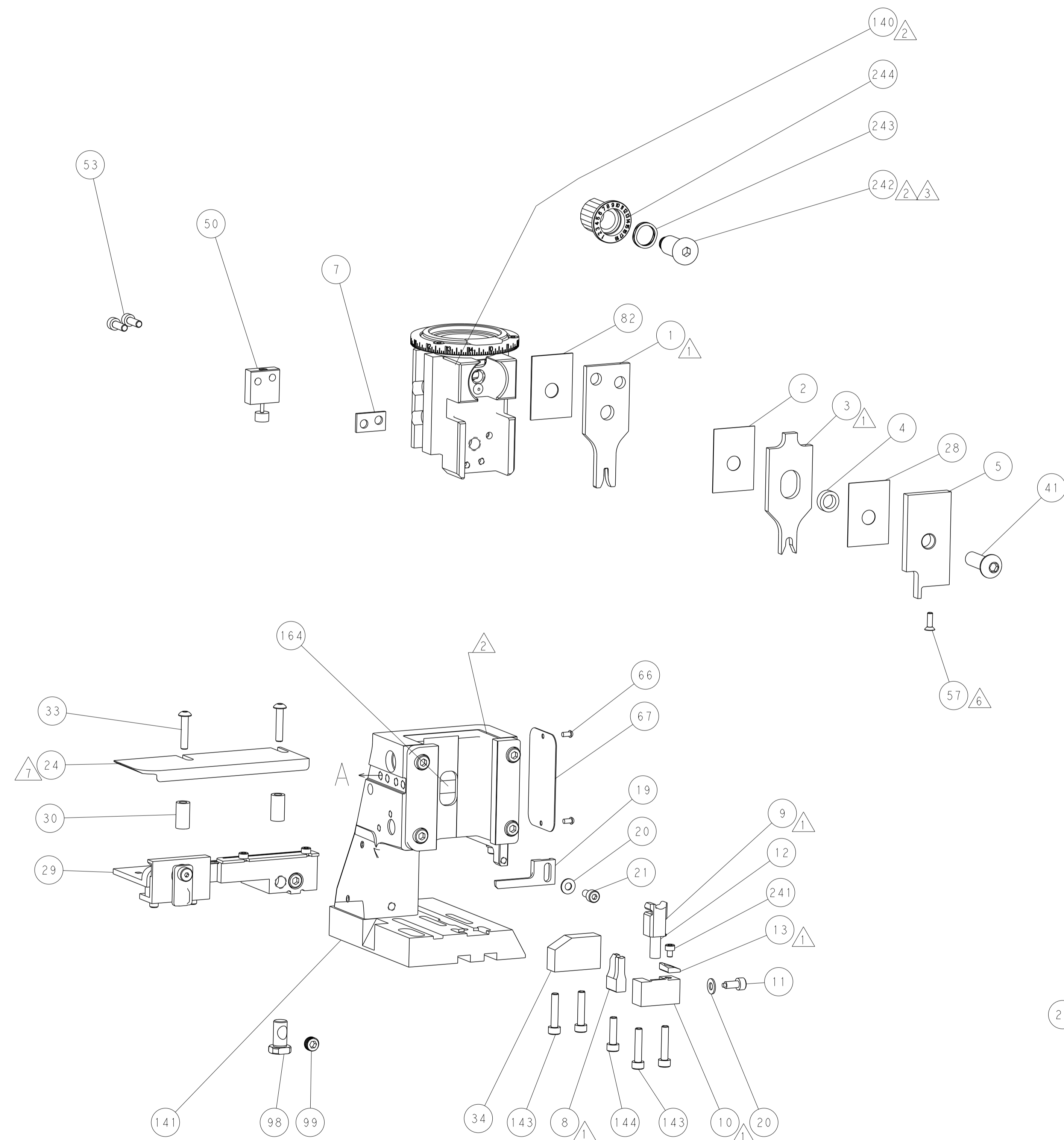
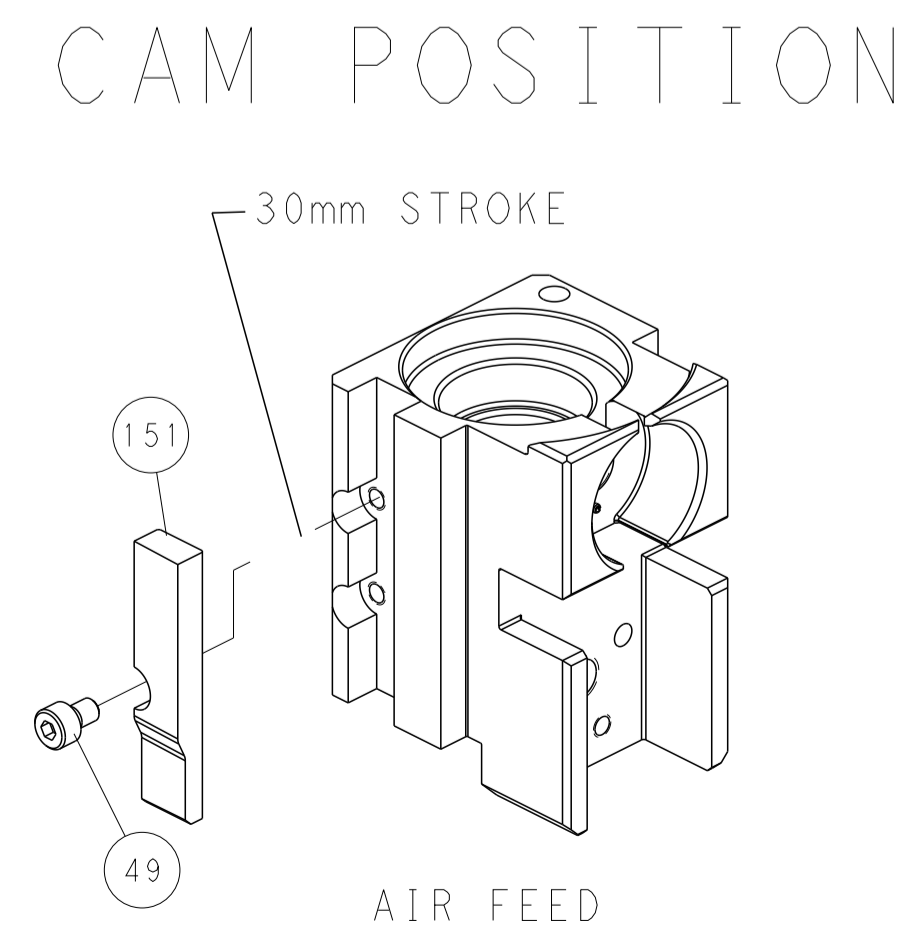
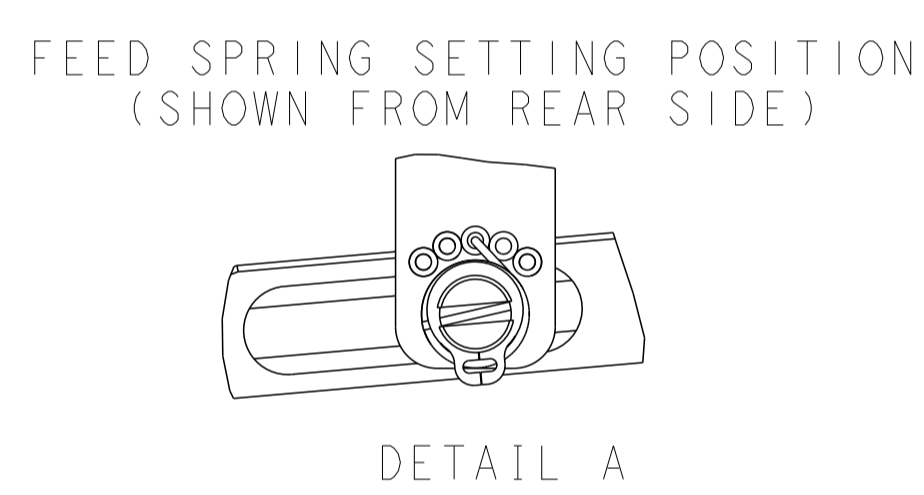
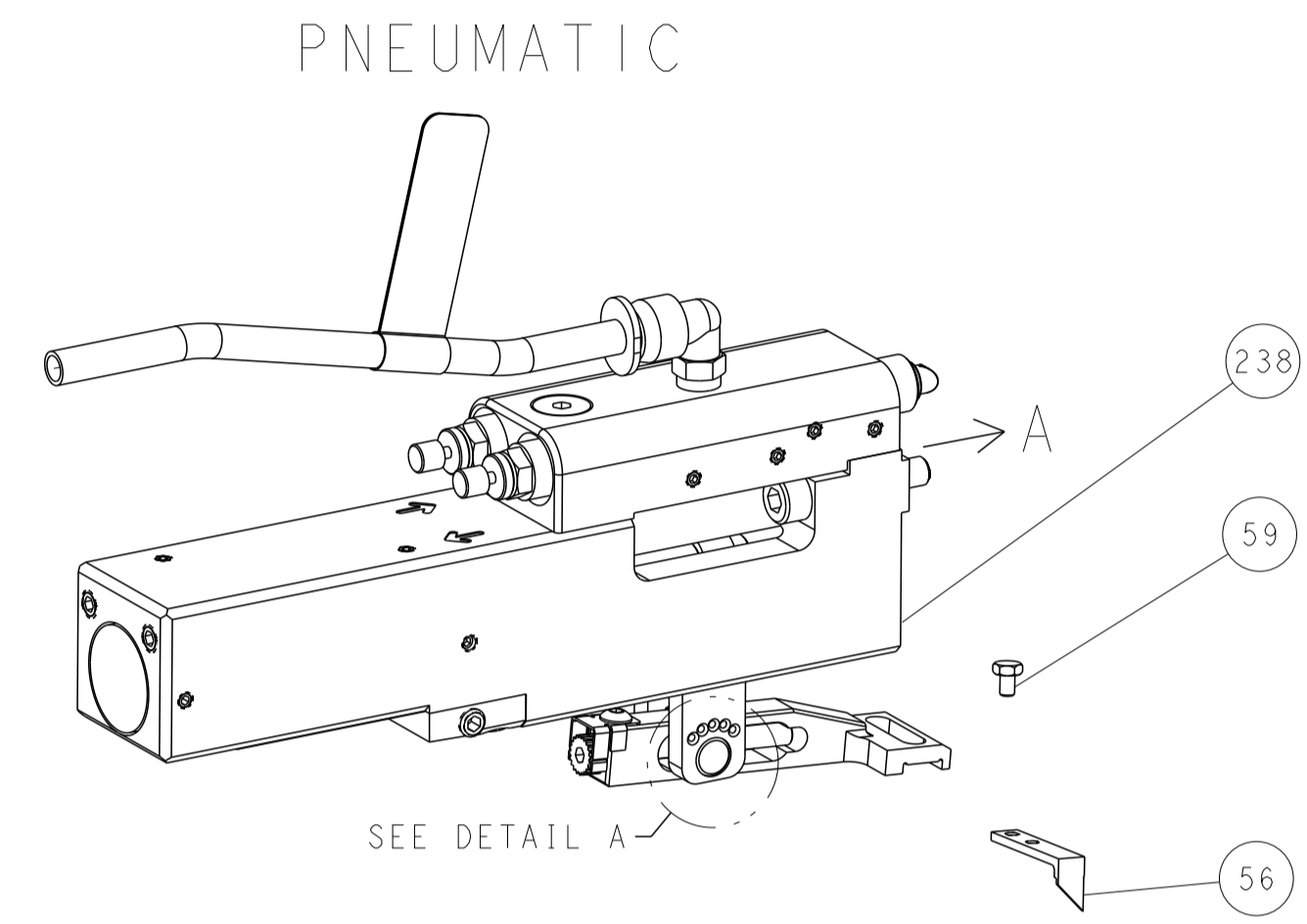

PACIFIC VERSION  
 Shown on sheets 3 of 4 & 4 of 4  
 (Atlantic version shown on sheets 1 of 4 & 2 of 4)

<small>THIS DRAWING IS UNPUBLISHED. RELEASED FOR PUBLICATION. ALL RIGHTS RESERVED. THIS DRAWING IS UNPUBLISHED. RELEASED FOR PUBLICATION. ALL RIGHTS RESERVED. THIS DRAWING IS UNPUBLISHED. RELEASED FOR PUBLICATION. ALL RIGHTS RESERVED.</small>		DWN: C. MOYER 10JAN2012 CHK: T. ELBIN 10JAN2012 APVD: T. ELBIN 10JAN2012	TE Connectivity Harrisburg, PA 17105-3608
DIMENSIONS: mm TOLERANCES UNLESS OTHERWISE SPECIFIED: 0 PLC ± 1 PLC ± 2 PLC ± 3 PLC ± 4 PLC ± ANGLES ± FINISH ±		NAME: Ocean Side Feed Applicator PRODUCT SPEC: APPLICATION SPEC: SIZE: A1 CAGE CODE: 00779 DRAWING NO: 2151499	RESTRICTED TO: Customer Accessible Production Drawing SCALE: 1:2 SHEET: 4 of 4 REV: G1