



TAOGLAS®



Datasheet

CGGBP.18.4.A.02

Part No:
CGGBP.18.4.A.02

Description

Embedded 18mm GPS/GLONASS/Galileo/BeiDou Patch Antenna,
1561/1575/1602MHz

Features:

- 18*18*4mm Ceramic patch
- High Gain (up to 4.5.dBi typ.)
- Excellent stability on the three GNSS systems
- Optimized radiation patterns
- Pin Mount
- RoHS and REACH Compliant

1.	Introduction	2
2.	Specification	3
3.	Antenna Characteristics	5
4.	Radiation Patterns	9
5.	Mechanical Drawing	13
6.	Packaging	15
7.	Antenna Integration Guide	16
<hr/>		
	Changelog	22

Taoglas makes no warranties based on the accuracy or completeness of the contents of this document and reserves the right to make changes to specifications and product descriptions at any time without notice. Taoglas reserves all rights to this document and the information contained herein. Reproduction, use or disclosure to third parties without express permission is strictly prohibited.



1. Introduction



This 18mm square embedded ceramic GPS/GLONASS/Galileo/BeiDou patch antenna's wide band of operation leads to excellent gain and radiation pattern stability on all four common commercial GNSS systems worldwide.

Compared to using a smaller antenna, this will translate into the GNSS system having much higher location accuracy, improved reliability of lock in urban areas, better signal reception, with more satellites acquired and a quicker time to first fix.

The patch is mounted via pin and double-sided adhesive. This patch can be tuned subject to NRE and MOQ, for further information please contact your regional Taoglas customer support team.

2. Specification

GNSS Frequency Bands					
GPS	L1 1575.42 MHz	L2 1227.6 MHz	L5 1176.45 MHz		
	■	□	□		
GLONASS	G1 1602 MHz	G2 1248 MHz	G3 1207 MHz		
	■	□	□		
Galileo	E1 1575.24 MHz	E5a 1176.45 MHz	E5b 1201.5 MHz	E6 1278.75 MHz	
	■	□	□	□	
BeiDou	B1C 1575.42 MHz	B1I 1561 MHz	B2a 1176.45 MHz	B2b 1207.14 MHz	B3 1268.52 MHz
	■	■	□	□	□
L-Band	L-Band 1542 MHz				
	□				
QZSS (Regional)	L1 1575.42 MHz	L2C 1227.6 MHz	L5 1176.45 MHz	L6 1278.75e6	
	■	□	□	□	
IRNSS (Regional)	L5 1176.45 MHz				
	□				
SBAS	L1/E1/B1 1575.42 MHz	L5/B2a/E5a 1176.45 MHz	G1 1602 MHz	G2 1248 MHz	G3 1207 MHz
	■	□	■	□	□

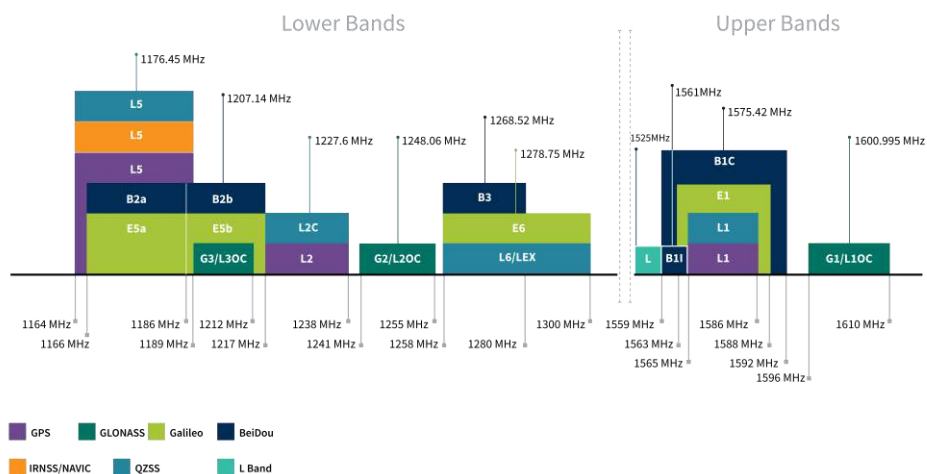

GNSS Bands and Constellations

GNSS Electrical			
Frequency (MHz)	1561	1575.42	1602
VSWR (max.)	1:1	1:1	1:1
Passive Antenna Efficiency (%) (Without cable loss)	58.14	68.09	72.3
Passive Antenna Gain at Zenith (dBic) (Without cable loss)	3.12	4.23	4.38
Polarization	RHCP		
Impedance	50 Ω		

Mechanical	
Dimensions	18 x 18 x 4mm
Weight	29g
Material	Ceramic

Environmental	
Operation Temperature	-40°C to 85°C
Storage Temperature	-40°C to 105°C
Relative Humidity	Non-condensing 65°C 95% RH

3. Antenna Characteristics

3.1 Test Setup

AUT



Vector Network Analyzer

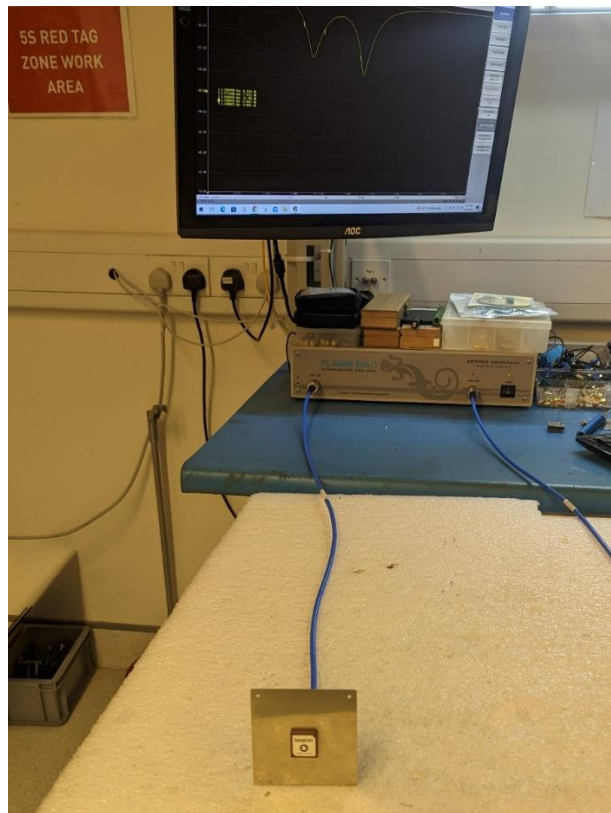

On 70mm x 70mm Ground Plane

3.2 Return Loss

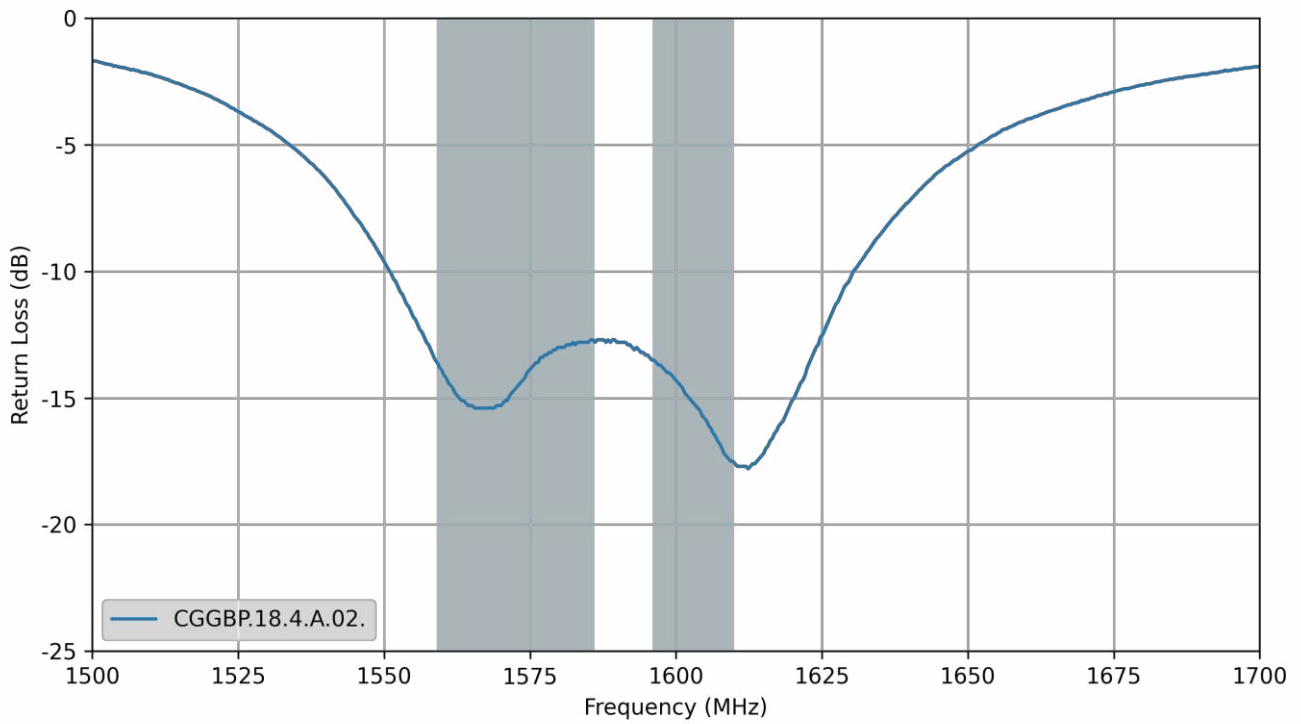

3.3 VSWR

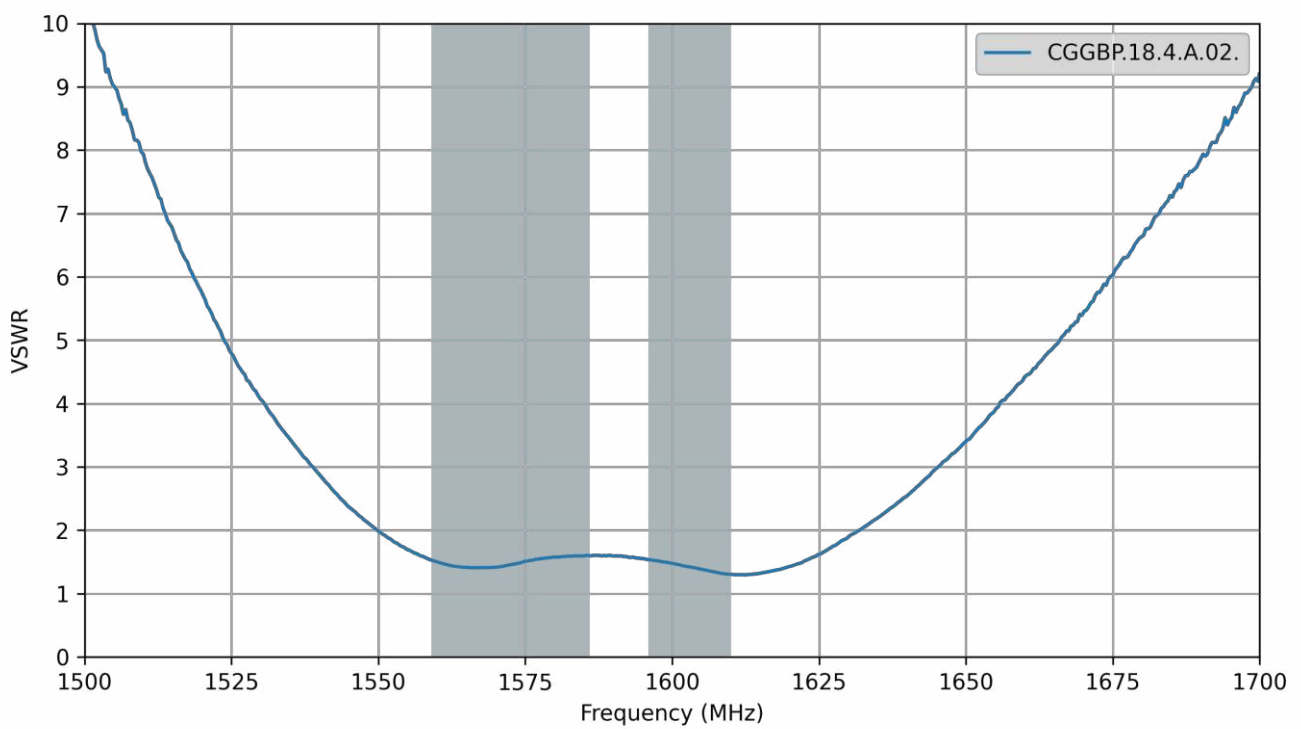

3.4 Efficiency

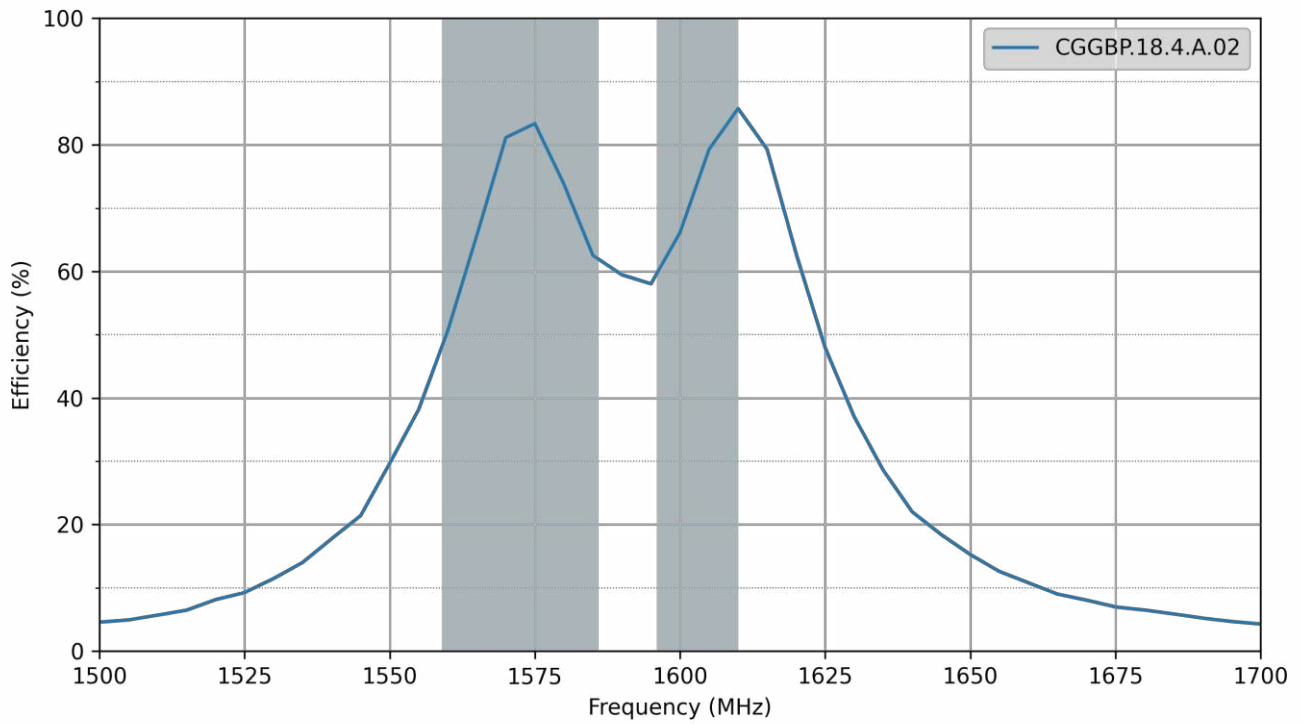

3.5 Average Gain

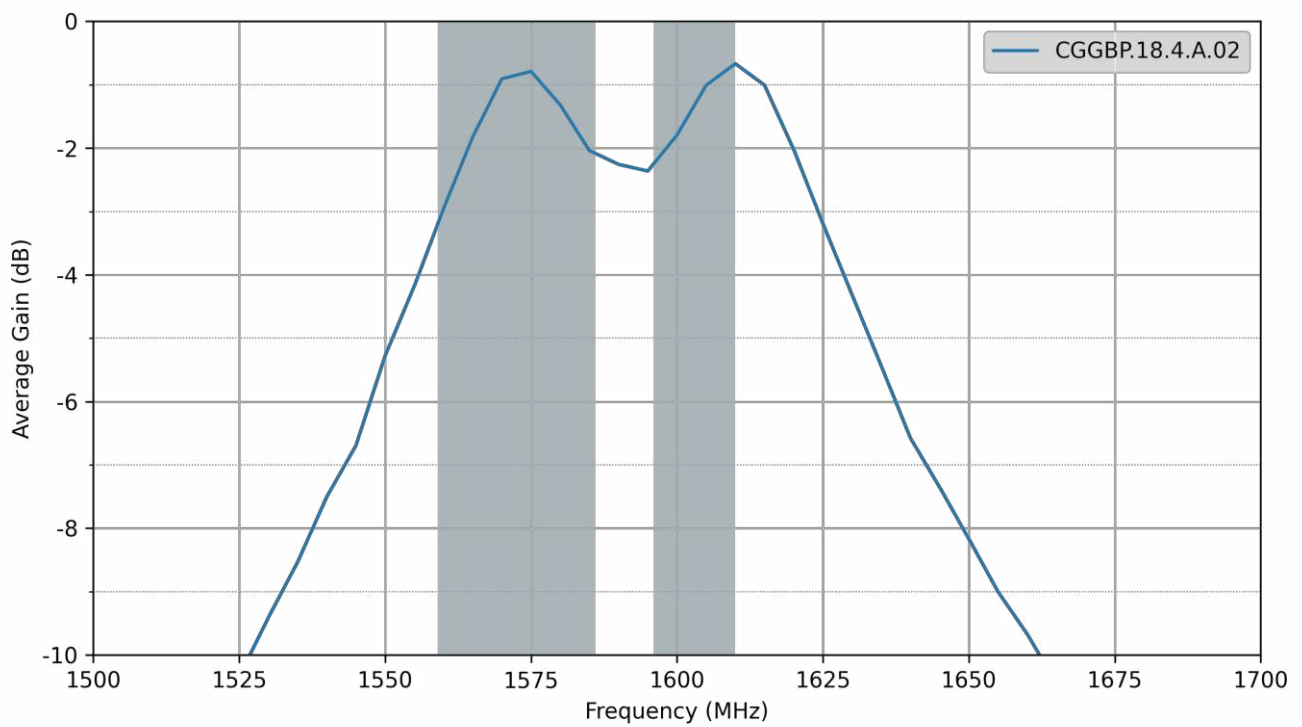

3.6 Peak Gain

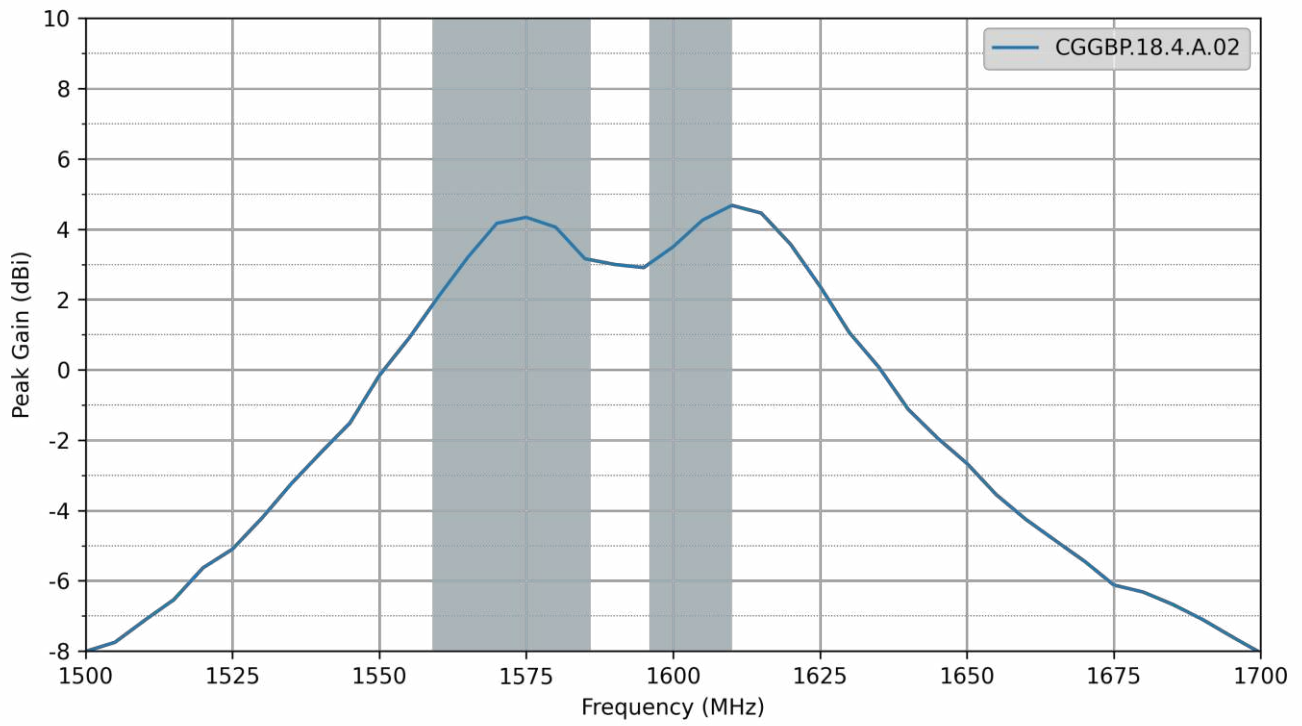

4. Radiation Patterns

4.1 Test Setup

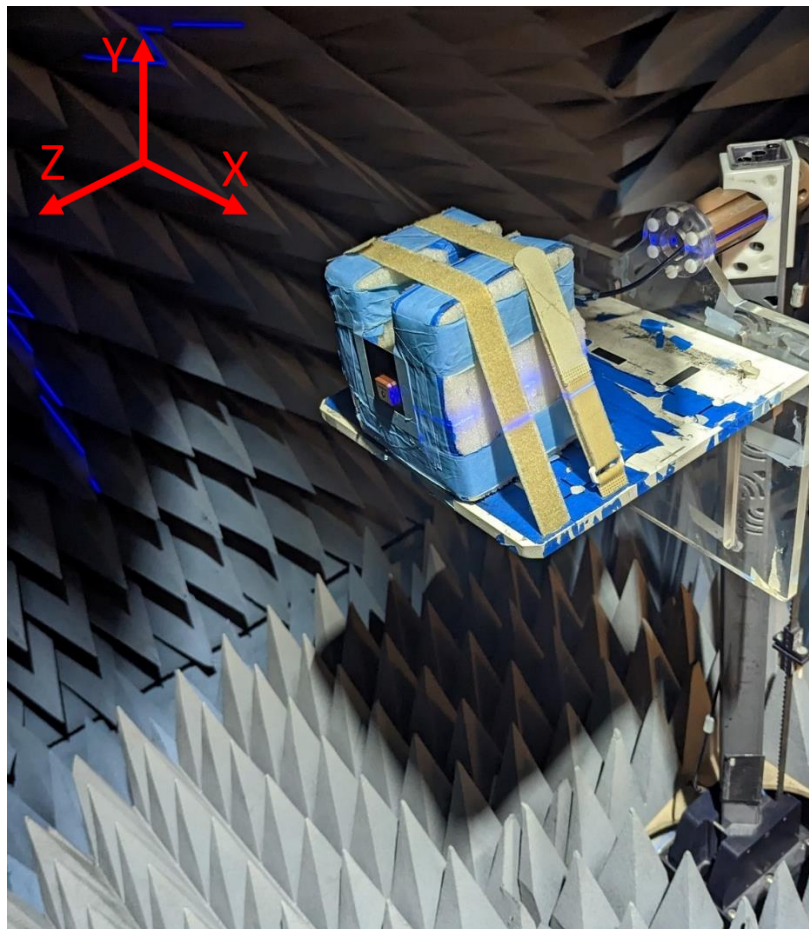
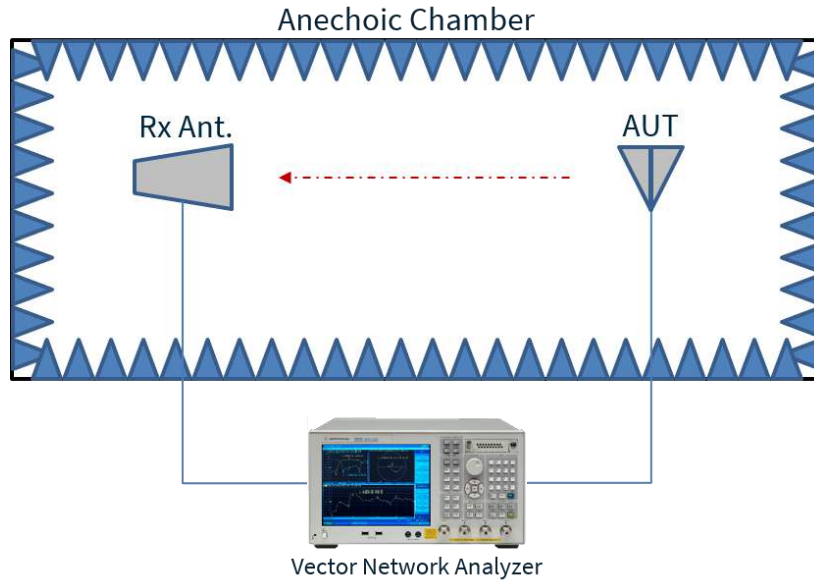

On 70mm x 70mm Ground Plane

4.2 CGGBP.18.4.A.02 Patterns at 1575 MHz

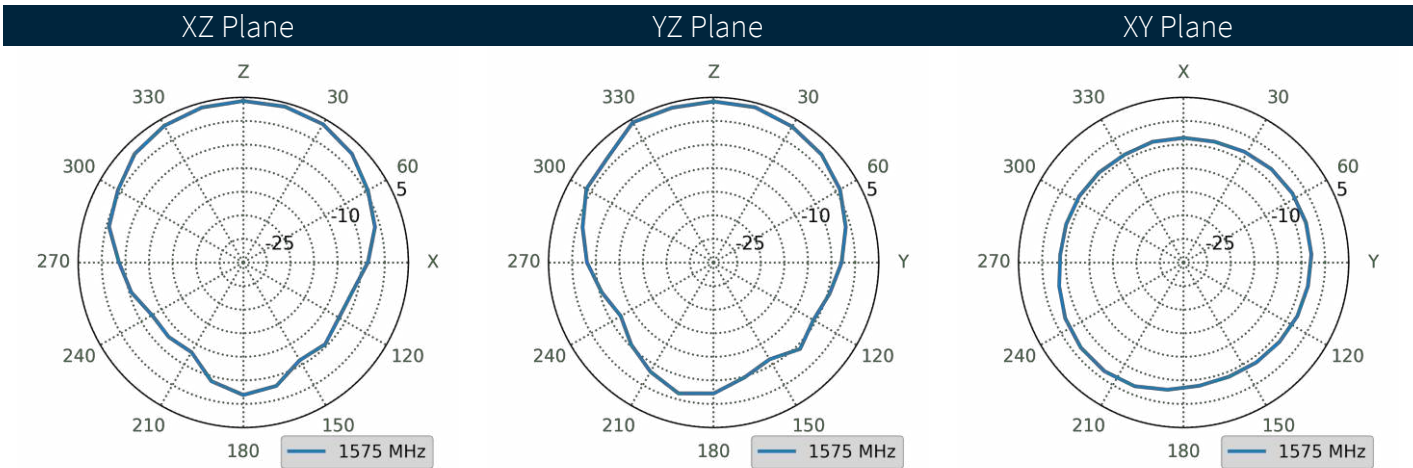
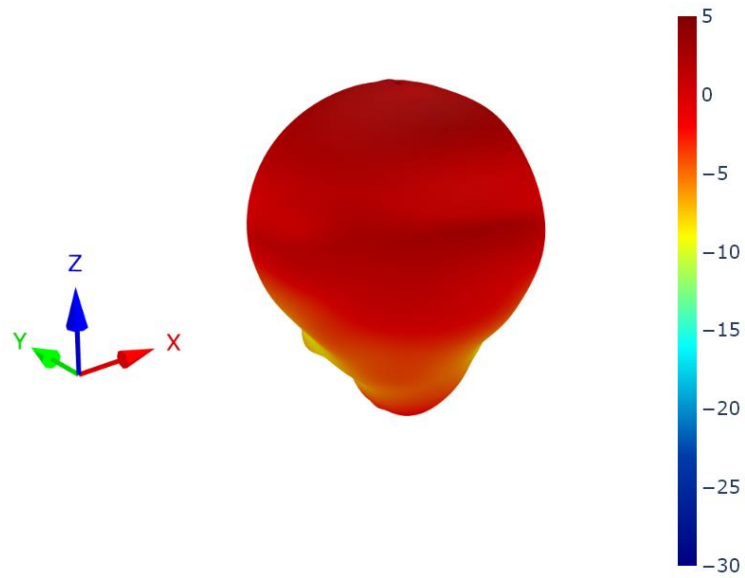

4.3 CGGBP.18.4.A.02 Patterns at 1602 MHz

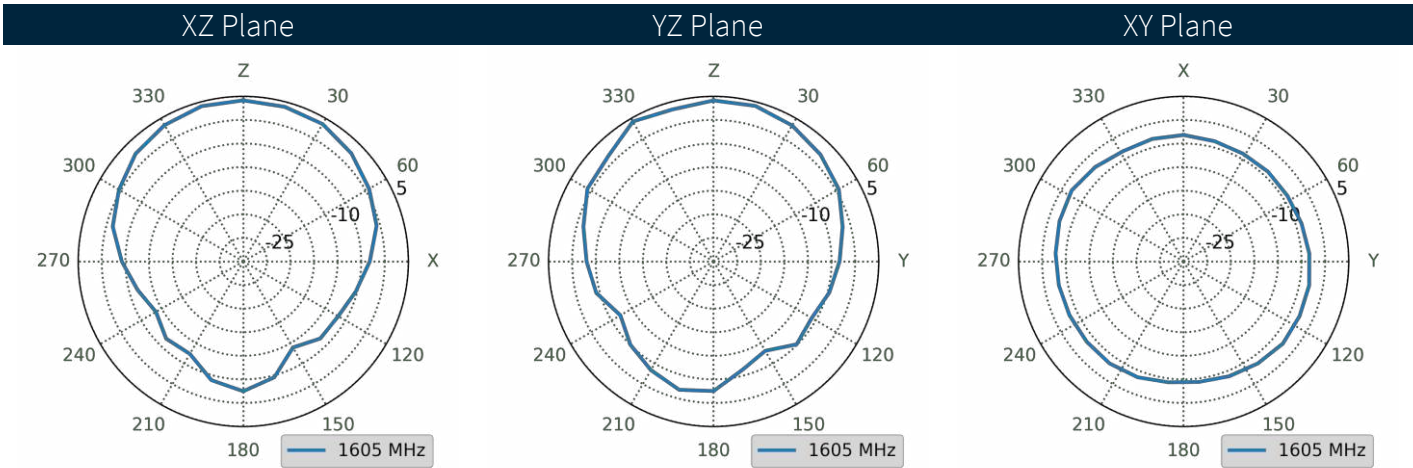
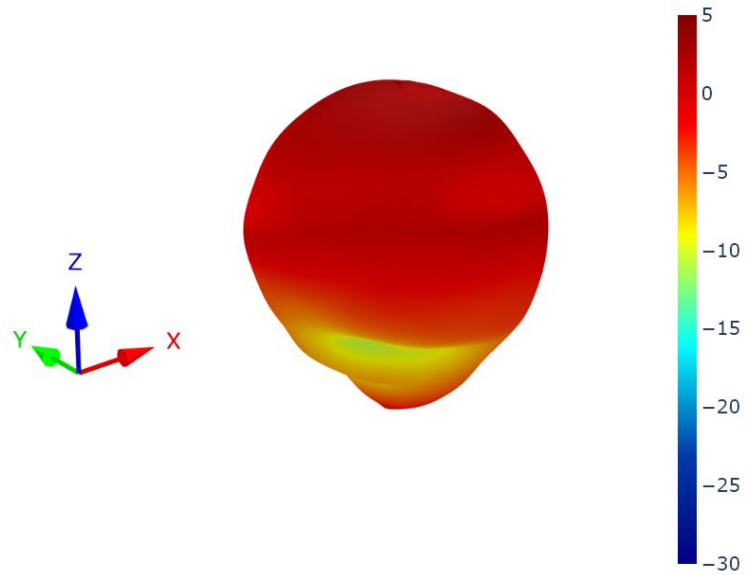

4.4 CGGBP.18.4.A.02 Patterns at 1561 MHz

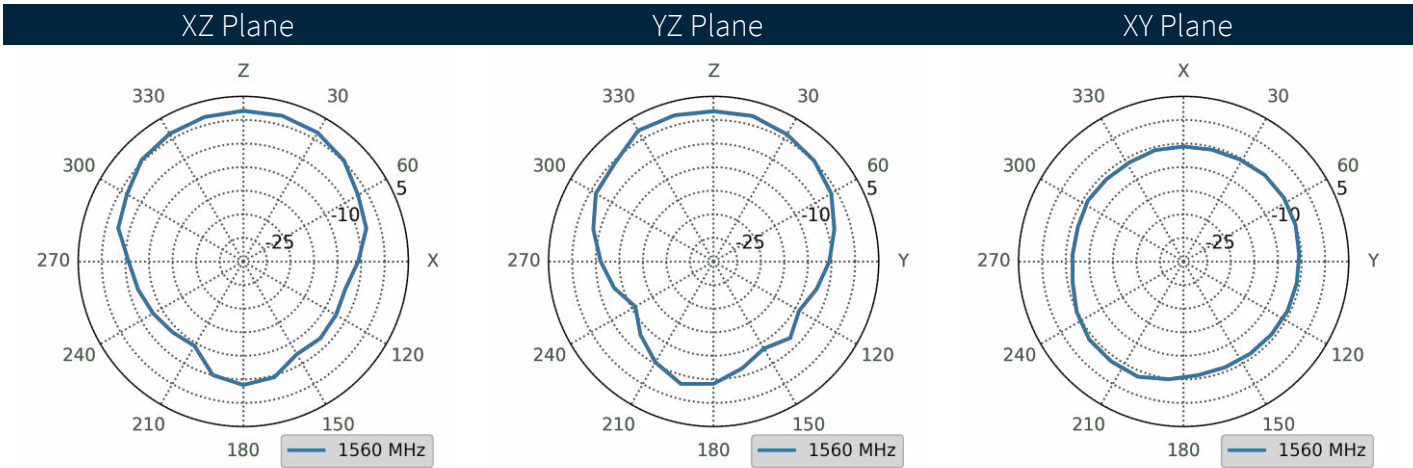
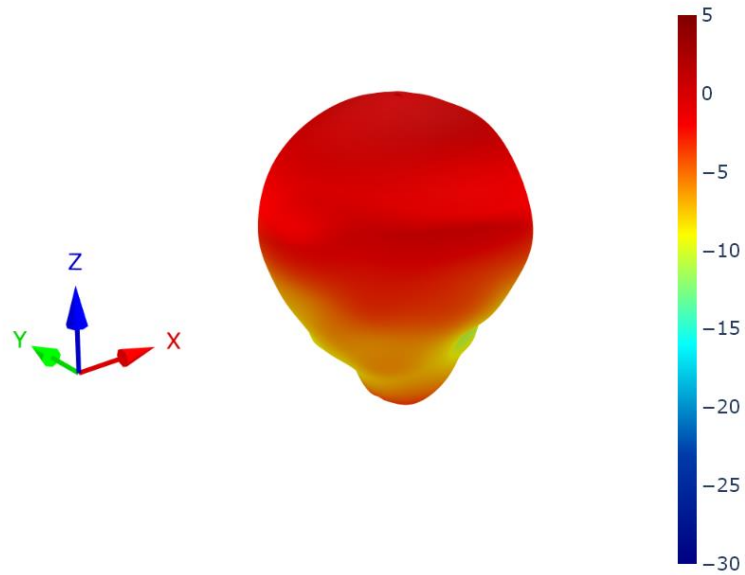

5. Mechanical Drawing

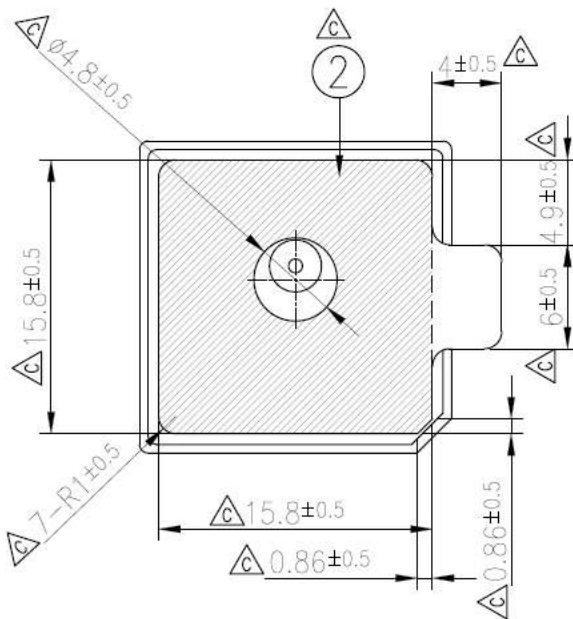
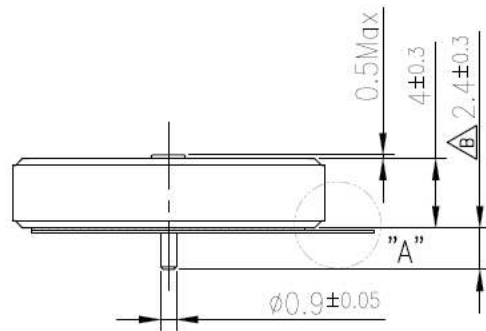
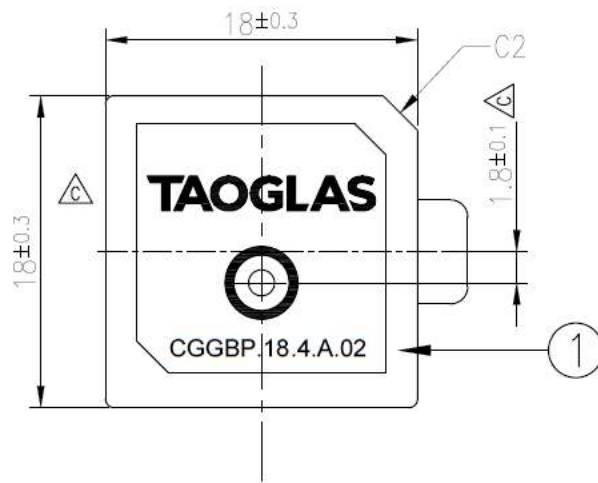

	Name	Material	Finish	QTY
	1 Patch (18x18x4mm)	Ceramic	Clear	1
	2 Double sided Adhesive	NITTO 5015	White Linter	1

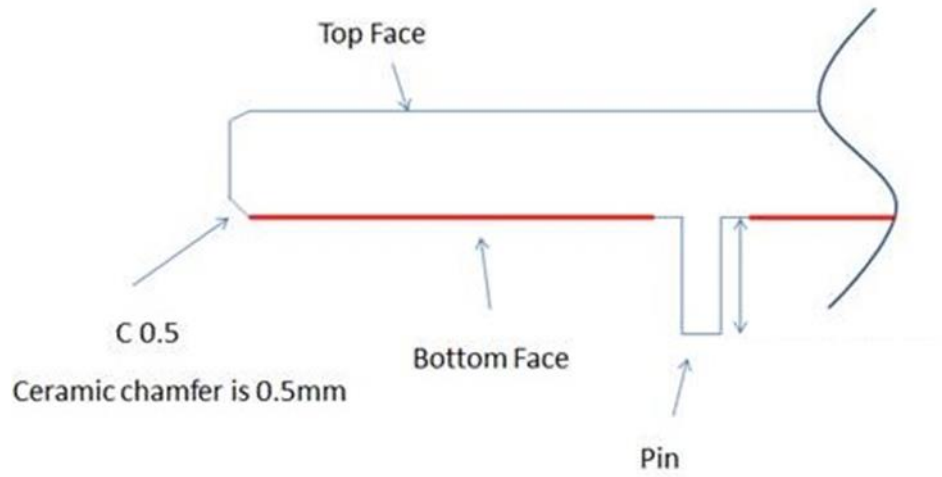

Red line shows the adhesive without Liner – thickness 0.08~0.1 mm

6. Packaging

25 pcs CGGBP.18.2.A.02 per tray
 Tray dimensions – 250*150*11mm

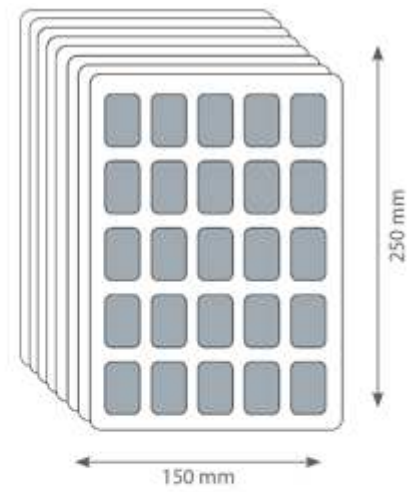

200 pcs CGGBP.18.2.A.02 per inner carton
 Inner carton dimensions – 96*263*154mm

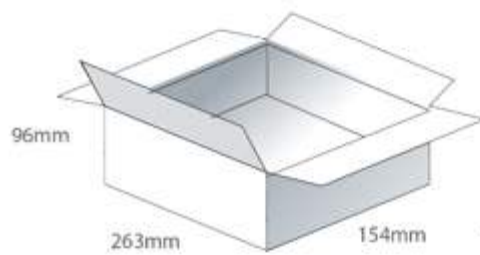

800 pcs CGGBP.18.2.A.02 per carton
 Carton dimensions – 370*370*300mm

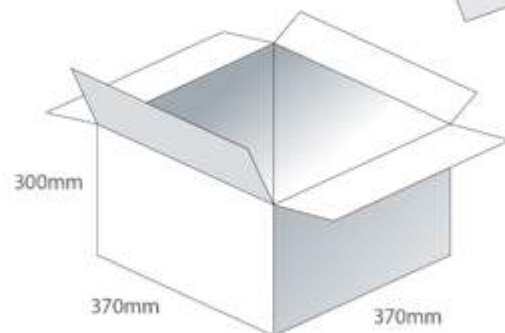

7. Antenna Integration Guide

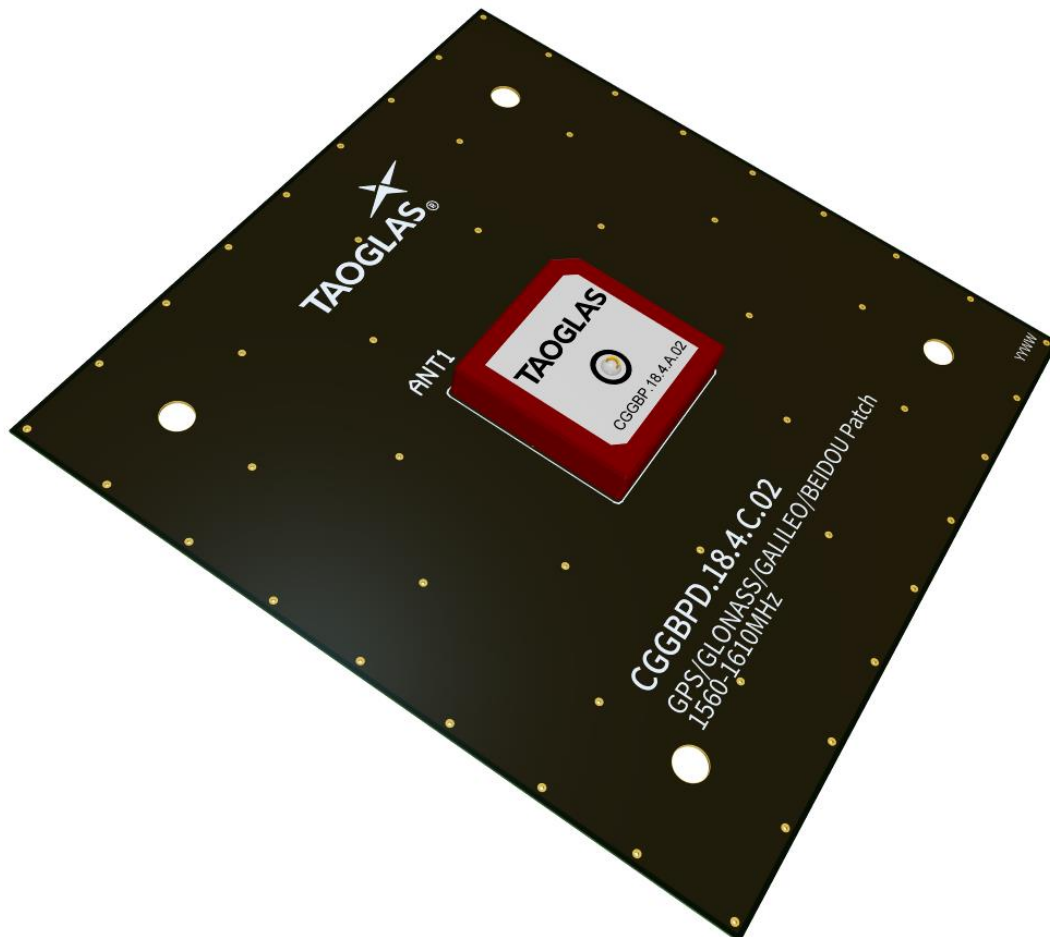

7.1 Schematic and Symbol Definition

The circuit symbol for the antenna is shown below. The antenna has 1 pin as indicated below.

Pin	Description
1	RF Feed



7.2 Antenna Integration

The antenna should be placed at the center of the ground plane with a length and width of 70mm. Maintaining a square symmetric ground plane shape and symmetric environment around the antenna is critical to maintaining the excellent axial ratio and phase center performance shown in this datasheet.



Top Side w/ Solder Mask



Top Side w/o Solder Mask

7.3 PCB Layout

The footprint and clearance on the PCB must comply with the antenna specification. The PCB layout shown in the diagram below demonstrates the antenna footprint.



Topside

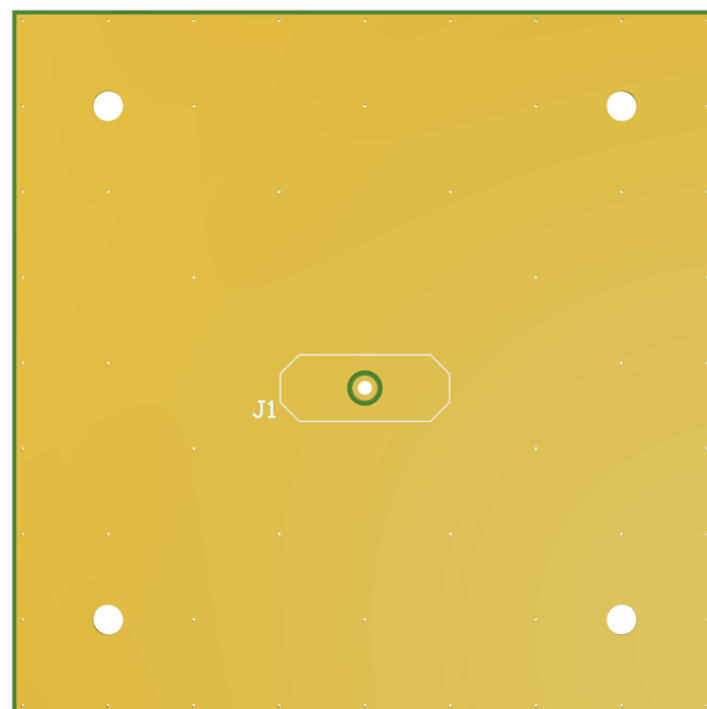

Bottom Side

7.4 Evaluation Board



Topside

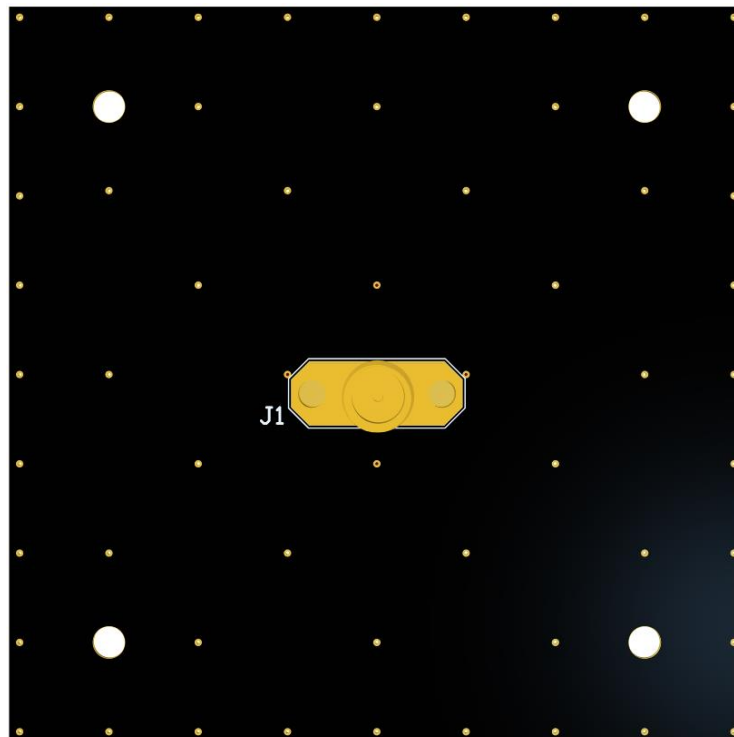

Bottom Side

7.5 Footprint

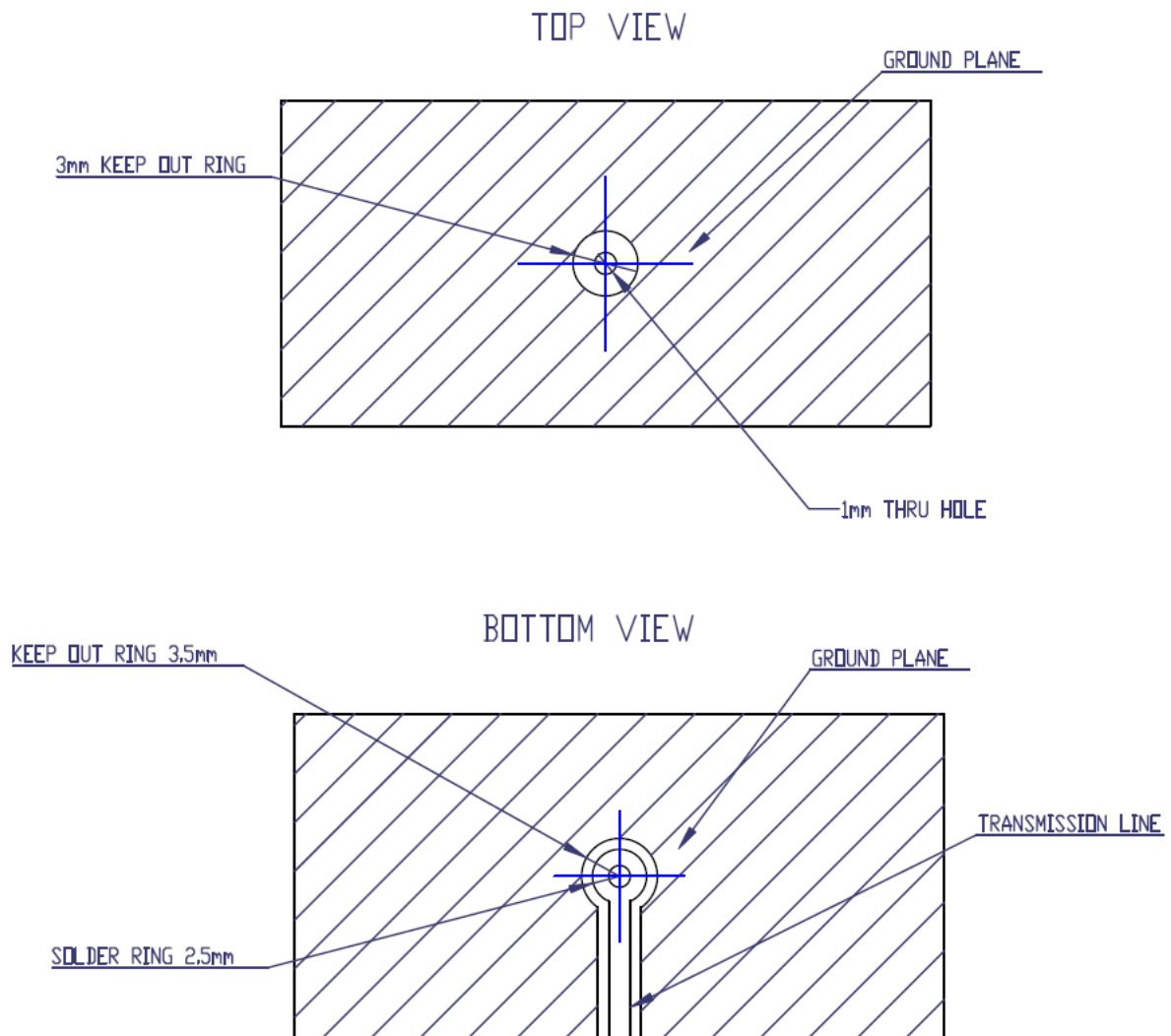

Changelog for the datasheet

SPE-14-8-072 – CGGBP.18.4.A.02

Revision: G (Current Version)

Date:	2023-06-08
Changes:	Updated Antenna Characteristics Updated Radiation Patterns
Changes Made by:	Aswin Biju

Previous Revisions

Revision: F

Date:	2023-03-22
Changes:	Antenna Integration Guide Added
Changes Made by:	Cesar Sousa

Revision: A (Original First Release)

Date:	2014-07-04
Notes:	
Author:	Author

Revision: E

Date:	2021-06-24
Changes:	Updated Specification
Changes Made by:	Dan Cantwell

Revision: D

Date:	2019-05-02
Changes:	Updated specifications
Changes Made by:	Paul Doyle

Revision: C

Date:	2015-02-02
Changes:	Amended drawing
Changes Made by:	Aine Doyle

Revision: B

Date:	2015-01-02
Changes:	Amended PCB footprint doc
Changes Made by:	Aine Doyle



www.taoglas.com

