

PRODUCT NUMBER	QUANTITY PER REEL	PACKAGING
73348-Y01(LF)	15000	CARDBOARD REEL

WHEN NEEDED, SUFFIX LETTER "LF" INDICATES THE PRODUCT IS RoHS COMPATIBLE, SEE NOTE

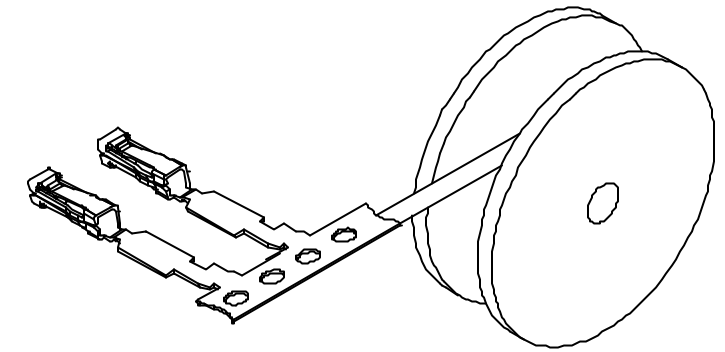
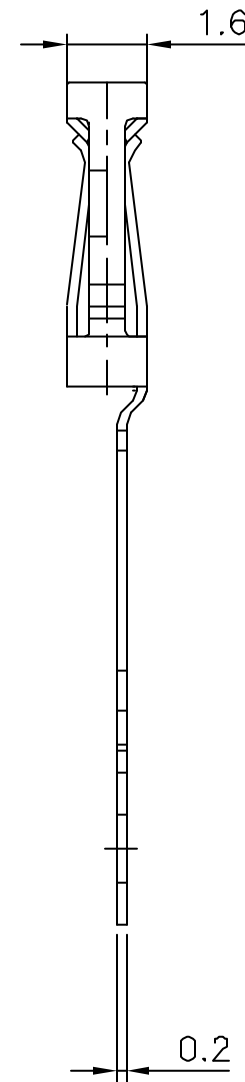
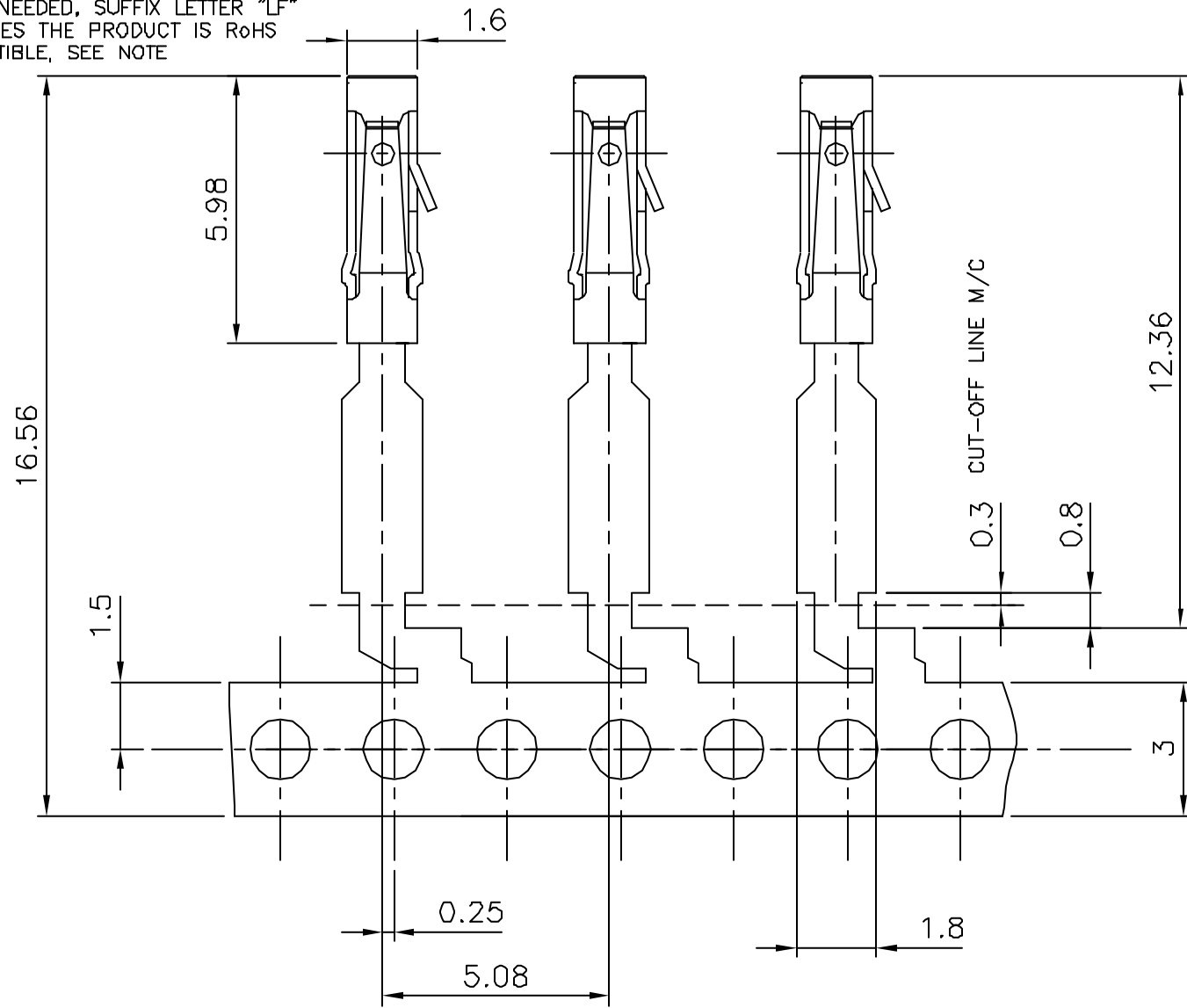

REELING AFTER STAMPING

NOTE:

MATERIAL: PHOSPHOR BRONZE, EXTRA HARD
RoHS COMPATIBLE PRODUCT SPECIFICATIONS

- a - PLATING:
- "LF" MEANS THE PRODUCT IS LEAD-FREE, 2μm MINIMUM MATTE TIN OVER 1.27μm MINIMUM NICKEL UNDERPLATE.
- b - LABELING:
- MEETS PACKAGING SPECS AS PER GS-14-920
- c - LEGAL STATEMENT: SEE GS-22-008

73348-3XXLF	0.76μm GOLD	Sn	0.3N MIN
			0.6N MAX
73348-4XXLF	5μm Sn	Sn	0.3N MIN
			0.6N MAX
73348-3XX	0.76μm GOLD	SnPb	0.3N MIN
			0.6N MAX
73348-4XX	5μm SnPb	SnPb	0.3N MIN
			0.6N MAX
PLATING CODE	CONTACT AREA	SOLDER TAIL	WITHDRAWAL FORCE USING SQUARE PIN 0.61
	PLATING THICKNESS OVER 1.27μm Ni		

mat'l. code		surface	tolerance	projection	product family
SEE NOTES		ISO 1302	ISO 416 ISO 1101	AS13	DUFLEX
Ltr	ecr no	dr	date	tolerances unless otherwise specified	title
D	FD4-0374	DLE	D4.11.18	Linear	DUFLEX TERM.
E	FO8-D203	DLE	D6.06.20	±2°	WITHOUT IDC
F	F07-027	LMU	D7.12.08	scale 10:1	sheet 1 of 1
		dr	D LEGRAND	0708.06.20	size
		enrg	P NIZZI	06.06.20	A3
		chr	P NIZZI	06.06.20	
		appd	P NZ	06.06.20	
sheet index	revision sheet				type CUSTOMER Drawing