

MADE IN THE USA

Companion Products (each sold separately):

- FM100-0212, Face Mask Dispenser - Universal Boxed - Earloop
- GL300-0212, Glove Box Dispenser - Triple with Dividers



FM100-0212



GL300-0212

Product Description:

- Gown Dispenser - Universal Boxed
- Holds a variety of boxed individually wrapped disposable isolation gowns
- Keyholes for wall mounting
- Made of Quartz Beige ABS Plastic

Primary Area for Product Usage:

- Patient care areas: ICU, medical clinics and offices, oncology, interventional radiation, labs
- Any location where PPE supplies are used for isolation and staff protection

Dispenses:

Most major manufacturers' isolation gown boxes:

- Boxes no smaller than 5.50"W x 8.50"H x 3.75"D (12.1 cm x 20.3 cm x 12.7 cm)
- Boxes no larger than 7.75"W x 12.00"H x 4.75"D (19.7 cm x 27.3 cm x 12.1 cm)

Package Specifications:

- Package Quantity: 6 per case
- 16"L x 12"W x 12"H (40.6 cm x 30.5 cm x 30.5 cm)
- 15.0 lbs (6.8 kg) - approximated

Product Specifications (overall external dimensions):

- 7.94"W x 9.88"H x 4.94"D (20.2 cm x 25.0 cm x 12.6 cm)
- 1.01 lbs (0.5 kg) - approximated

Mounting Specifications:

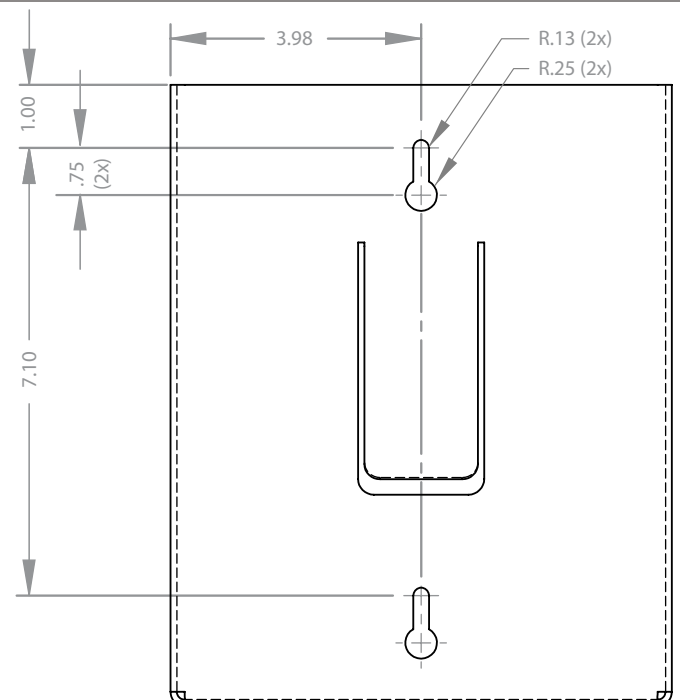



Installation

Always mount dispensers securely *prior* to loading with product.

- Spring design provides a secure fit for a wide assortment of boxed products.
- Open design conveniently allows dispensing of product through front and quick replenishment through top.

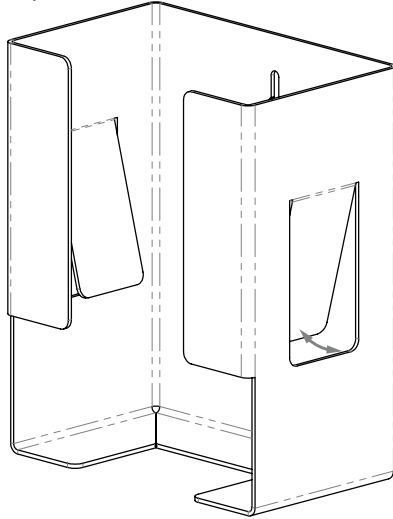

- Mount securely to a wall with screws approved and supplied by building maintenance.

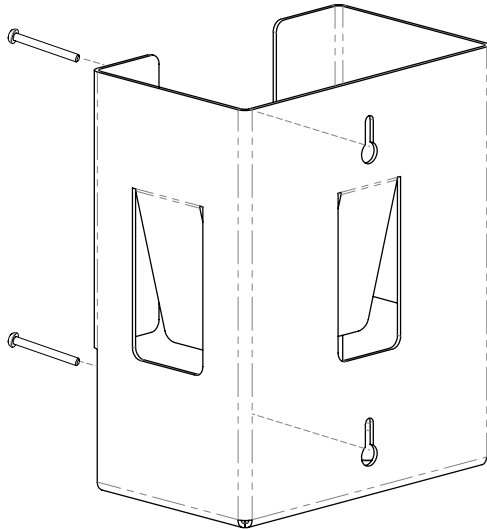

Parts included:

- Dispenser

Tools Required:

- No tools required to assemble dispenser

Characteristics & Care

ABS Plastic

Material Characteristics

Designed for Long-Term, Heavy-Duty Applications

The combination of copolymers (Acrylonitrile, Butadiene, and Styrene) gives ABS an excellent combination of strength, rigidity, and toughness.

ABS is chemical, stress-crack resistant, dimensionally stable, and will hold up to long-term use. It possesses high strength and performance characteristics at a reasonable cost.

Care and Cleaning

Use mild soap and water to clean. Petroleum-based oils, solvents, and paints should not be used.

Standard hospital cleaning supplies are approved for use on our ABS plastic products.