



# 1.8V, 2.9 $\mu$ A, 90kHz, Rail-to-Rail I/O OPERATIONAL AMPLIFIERS

## FEATURES

- **LOW NOISE:** 2.8 $\mu$ V<sub>PP</sub> (0.1Hz - 10Hz)
- **microPower:** 5.5 $\mu$ A (max)
- **LOW OFFSET VOLTAGE:** 1.5mV (max)
- **DC PRECISION:**
  - **CMRR:** 100dB
  - **PSRR:** 2 $\mu$ V/V
  - **A<sub>OL</sub>:** 120dB
- **WIDE SUPPLY VOLTAGE RANGE:** 1.8V to 5.5V
- **microSize PACKAGES:**
  - SC70-5, SOT23-5, SOT23-8, SO-8, TSSOP-14

## APPLICATIONS

- **BATTERY-POWERED INSTRUMENTS**
- **PORTABLE DEVICES**
- **MEDICAL INSTRUMENTS**
- **HANDHELD TEST EQUIPMENT**

## DESCRIPTION

The OPA379 family of micropower, low-voltage operational amplifiers is designed for battery-powered applications. These amplifiers operate on a supply voltage as low as 1.8V ( $\pm 0.9$ V). High-performance, single-supply operation with rail-to-rail capability (10 $\mu$ V max) makes the OPA379 family useful for a wide range of applications.

In addition to *microSize* packages, the OPA379 family of op amps features impressive bandwidth (90kHz), low bias current (5pA), and low noise (80nV/ $\sqrt{\text{Hz}}$ ) relative to the very low quiescent current (5.5 $\mu$ A max).

The OPA379 (single) is available in SC70-5, SOT23-5, and SO-8 packages. The OPA2379 (dual) comes in SOT23-8 and SO-8 packages. The OPA4379 (quad) is offered in a TSSOP-14 package. All versions are specified from  $-40^{\circ}\text{C}$  to  $+125^{\circ}\text{C}$ .

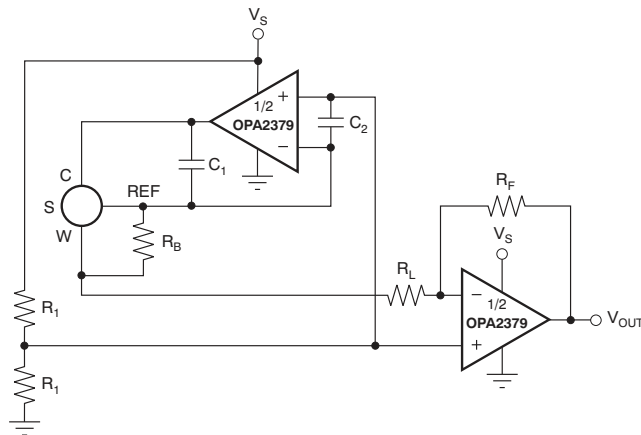

**Figure 1. OPA2379 in Portable Gas Meter Application**

**Table 1. OPAx379 RELATED PRODUCTS**

FEATURES	PRODUCT
1 $\mu$ A, 70kHz, 2mV $V_{OS}$ , 1.8V to 5.5V Supply	<a href="#">OPAx349</a>
1 $\mu$ A, 5.5kHz, 390 $\mu$ V $V_{OS}$ , 2.5V to 16V Supply	<a href="#">TLV240x</a>
1 $\mu$ A, 5.5kHz, 0.6mV $V_{OS}$ , 2.5V to 12V Supply	<a href="#">TLV224x</a>
7 $\mu$ A, 160kHz, 0.5mV $V_{OS}$ , 2.7V to 16V Supply	<a href="#">TLV27Lx</a>
7 $\mu$ A, 160kHz, 0.5mV $V_{OS}$ , 2.7V to 16V Supply	<a href="#">TLV238x</a>
20 $\mu$ A, 350kHz, 2mV $V_{OS}$ , 2.3V to 5.5V Supply	<a href="#">OPAx347</a>
20 $\mu$ A, 500kHz, 550 $\mu$ V $V_{OS}$ , 1.8V to 3.6V Supply	<a href="#">TLV276x</a>
45 $\mu$ A, 1MHz, 1mV $V_{OS}$ , 2.1V to 5.5V Supply	<a href="#">OPAx348</a>



Please be aware that an important notice concerning availability, standard warranty, and use in critical applications of Texas Instruments semiconductor products and disclaimers thereto appears at the end of this data sheet.

All trademarks are the property of their respective owners.



This integrated circuit can be damaged by ESD. Texas Instruments recommends that all integrated circuits be handled with appropriate precautions. Failure to observe proper handling and installation procedures can cause damage.

ESD damage can range from subtle performance degradation to complete device failure. Precision integrated circuits may be more susceptible to damage because very small parametric changes could cause the device not to meet its published specifications.

## ABSOLUTE MAXIMUM RATINGS<sup>(1)</sup>

Over operating free-air temperature range (unless otherwise noted).

		OPA379, OPA2379, OPA4379	UNIT
Supply Voltage	$V_S = (V_+) - (V_-)$	+7	V
Signal Input Terminals, Voltage <sup>(2)</sup>		$(V_-) - 0.5$ to $(V_+) + 0.5$	V
Signal Input Terminals, Current <sup>(2)</sup>		±10	mA
Output Short-Circuit <sup>(3)</sup>		Continuous	
Operating Temperature	$T_A$	–40 to +125	°C
Storage Temperature	$T_A$	–65 to +150	°C
Junction Temperature	$T_J$	+150	°C
ESD Rating	Human Body Model (HBM)	2000	V
	Charged Device Model (CDM)	1000	V

- (1) Stresses above these ratings may cause permanent damage. Exposure to absolute maximum conditions for extended periods may degrade device reliability. These are stress ratings only, and functional operation of the device at these or any other conditions beyond those specified is not supported.
- (2) Input terminals are diode-clamped to the power-supply rails. Input signals that can swing more than 0.5V beyond the supply rails should be current-limited to 10mA or less.
- (3) Short-circuit to ground, one amplifier per package.

## PACKAGE/ORDERING INFORMATION<sup>(1)</sup>

PRODUCT	PACKAGE-LEAD	PACKAGE DESIGNATOR	PACKAGE MARKING
OPA379	SC70–5	DCK	AYR
	SOT23–5	DBV	B53
	SO–8	D	OPA379A
OPA2379	SOT23–8	DCN	B61
	SO–8	D	OPA2379A
OPA4379	TSSOP–14	PW	OPA4379A

- (1) For the most current package and ordering information see the Package Option Addendum at the end of this document, or see the TI web site at [www.ti.com](http://www.ti.com).

**PIN CONFIGURATIONS**

**OPA379  
SC70-5  
(TOP VIEW)**

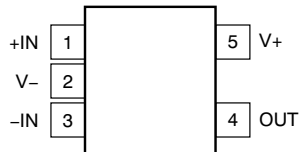

**OPA379  
SOT23-5  
(TOP VIEW)**

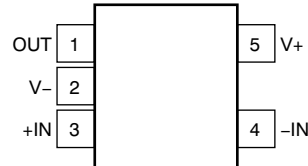

**OPA379  
SO-8  
(TOP VIEW)**

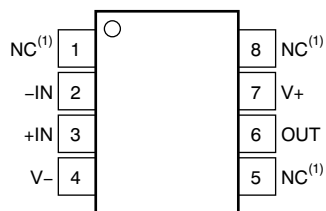

**OPA2379(2)  
SOT23-8  
(TOP VIEW)**

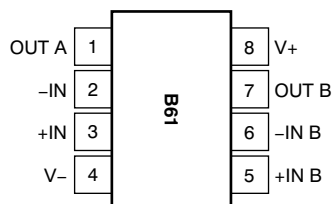

**OPA2379  
SO-8  
(TOP VIEW)**

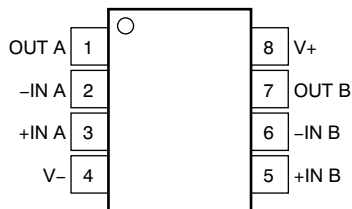

**OPA4379  
TSSOP-14  
(TOP VIEW)**

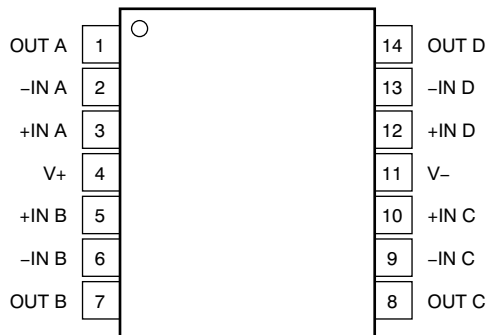

(1) NC denotes no internal connection.

(2) Pin 1 of the SOT23-8 package is determined by orienting the package marking as shown.

**ELECTRICAL CHARACTERISTICS:  $V_S = +1.8V$  to  $+5.5V$**

**Boldface** limits apply over the specified temperature range indicated.

At  $T_A = +25^\circ C$ ,  $R_L = 25k\Omega$  connected to  $V_S/2$ , and  $V_{CM} < (V+) - 1V$ , unless otherwise noted.

PARAMETER	TEST CONDITIONS	OPA379, OPA2379, OPA4379			UNIT	
		MIN	TYP	MAX		
<b>OFFSET VOLTAGE</b>						
Initial Offset Voltage	$V_{OS}$ $V_S = 5V$		0.4	1.5	mV	
<b>Over <math>-40^\circ C</math> to <math>+125^\circ C</math></b>				<b>2</b>	<b>mV</b>	
<b>Drift, <math>-40^\circ C</math> to <math>+85^\circ C</math></b>	$dV_{OS}/dT$		<b>1.5</b>		$\mu V/^\circ C$	
<b>Drift, <math>-40^\circ C</math> to <math>+125^\circ C</math></b>			<b>2.7</b>		$\mu V/^\circ C$	
vs Power Supply	PSRR		2	10	$\mu V/V$	
<b>Over <math>-40^\circ C</math> to <math>+125^\circ C</math></b>				<b>20</b>	$\mu V/V$	
<b>INPUT VOLTAGE RANGE</b>						
Common-Mode Voltage Range	$V_{CM}$		$(V-) - 0.1$ to $(V+) + 0.1$		V	
Common-Mode Rejection Ratio <sup>(1)</sup>	CMRR	$(V-) < V_{CM} < (V+) - 1V$	90	100	dB	
<b>Over <math>-40^\circ C</math> to <math>+85^\circ C</math></b>		$(V-) < V_{CM} < (V+) - 1V$	<b>80</b>		<b>dB</b>	
<b>Over <math>-40^\circ C</math> to <math>+125^\circ C</math></b>		$(V-) < V_{CM} < (V+) - 1V$	<b>62</b>		<b>dB</b>	
<b>INPUT BIAS CURRENT</b>						
Input Bias Current	$I_B$	$V_S = 5V, V_{CM} \leq V_S/2$		$\pm 5$	$\pm 50$	pA
Input Offset Current	$I_{OS}$	$V_S = 5V$		$\pm 5$	$\pm 50$	pA
<b>INPUT IMPEDANCE</b>						
Differential				$10^{13} \parallel 3$	$\Omega \parallel pF$	
Common-Mode				$10^{13} \parallel 6$	$\Omega \parallel pF$	
<b>NOISE</b>						
Input Voltage Noise		$f = 0.1Hz$ to $10Hz$		2.8	$\mu V_{PP}$	
Input Voltage Noise Density	$e_n$	$f = 1kHz$		80	$nV/\sqrt{Hz}$	
Input Current Noise Density	$i_n$	$f = 1kHz$		1	$fA/\sqrt{Hz}$	
<b>OPEN-LOOP GAIN</b>						
Open-Loop Voltage Gain	$A_{OL}$	$V_S = 5V, R_L = 25k\Omega, 100mV < V_O < (V+) - 100mV$	100	120	dB	
<b>Over <math>-40^\circ C</math> to <math>+125^\circ C</math></b>		<b><math>V_S = 5V, R_L = 25k\Omega, 100mV &lt; V_O &lt; (V+) - 100mV</math></b>	<b>80</b>		<b>dB</b>	
		$V_S = 5V, R_L = 5k\Omega, 500mV < V_O < (V+) - 500mV$	100	120	dB	
<b>Over <math>-40^\circ C</math> to <math>+125^\circ C</math></b>		<b><math>V_S = 5V, R_L = 5k\Omega, 500mV &lt; V_O &lt; (V+) - 500mV</math></b>	<b>80</b>		<b>dB</b>	
<b>OUTPUT</b>						
Voltage Output Swing from Rail		$R_L = 25k\Omega$		5	10	mV
<b>Over <math>-40^\circ C</math> to <math>+125^\circ C</math></b>		<b><math>R_L = 25k\Omega</math></b>			<b>15</b>	<b>mV</b>
		$R_L = 5k\Omega$		25	50	mV
<b>Over <math>-40^\circ C</math> to <math>+125^\circ C</math></b>		<b><math>R_L = 5k\Omega</math></b>			<b>75</b>	<b>mV</b>
Short-Circuit Current	$I_{SC}$			$\pm 5$	mA	
Capacitive Load Drive	$C_{LOAD}$		<a href="#">See Typical Characteristics</a>			
Closed-Loop Output Impedance	$R_{OUT}$	$G = 1, f = 1kHz, I_O = 0$		10	$\Omega$	
Open-Loop Output Impedance	$R_O$	$f = 100kHz, I_O = 0$		28	k $\Omega$	
<b>FREQUENCY RESPONSE</b>						
Gain Bandwidth Product	GBW	$C_{LOAD} = 30pF$		90	kHz	
Slew Rate	SR	$G = +1$		0.03	V/ $\mu s$	
Overload Recovery Time		$V_{IN} \times GAIN > V_S$		25	$\mu s$	
Turn-On Time	$t_{ON}$			1	ms	

(1) See Typical Characteristic graph, *Common-Mode Rejection Ratio vs Frequency* (Figure 3).

**ELECTRICAL CHARACTERISTICS:  $V_S = +1.8V$  to  $+5.5V$  (continued)**

**Boldface** limits apply over the specified temperature range indicated.

At  $T_A = +25^\circ C$ ,  $R_L = 25k\Omega$  connected to  $V_S/2$ , and  $V_{CM} < (V+) - 1V$ , unless otherwise noted.

PARAMETER	TEST CONDITIONS	OPA379, OPA2379, OPA4379			UNIT
		MIN	TYP	MAX	
<b>POWER SUPPLY</b>					
Specified/Operating Voltage Range	$V_S$	1.8		5.5	V
Quiescent Current per Amplifier	$I_Q$		2.9	5.5	$\mu A$
<b>Over <math>-40^\circ C</math> to <math>+125^\circ C</math></b>				<b>10</b>	<b><math>\mu A</math></b>
<b>TEMPERATURE</b>					
Specified/Operating Range	$T_A$	$-40$		$+125$	$^\circ C$
Storage Range	$T_J$	$-65$		$+150$	$^\circ C$
Thermal Resistance	$\theta_{JA}$				
SC70-5			250		$^\circ C/W$
SOT23-5			200		$^\circ C/W$
SOT23-8, TSSOP-14, SO-8			150		$^\circ C/W$

## TYPICAL CHARACTERISTICS

At  $T_A = +25^\circ\text{C}$ ,  $V_S = 5\text{V}$ , and  $R_L = 25\text{k}\Omega$  connected to  $V_S/2$ , unless otherwise noted.

**OPEN-LOOP GAIN AND PHASE vs FREQUENCY**

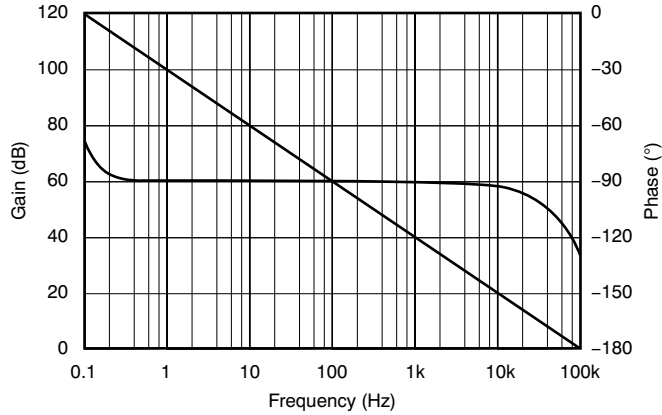

Figure 2.

**COMMON-MODE AND POWER-SUPPLY REJECTION RATIO vs FREQUENCY**

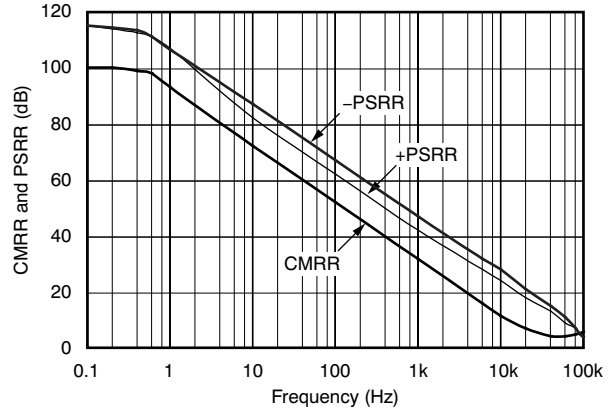

Figure 3.

**MAXIMUM OUTPUT VOLTAGE vs FREQUENCY**

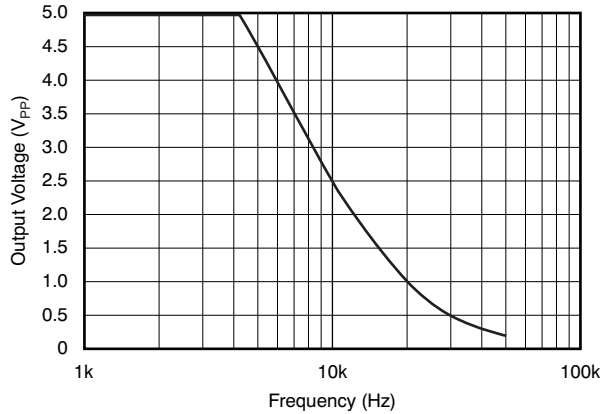

Figure 4.

**QUIESCENT CURRENT vs SUPPLY VOLTAGE**

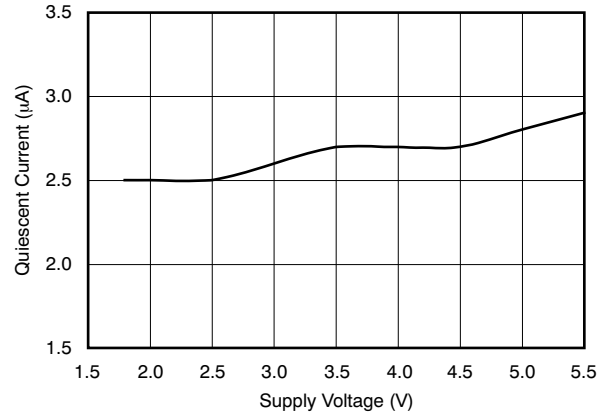

Figure 5.

**OUTPUT VOLTAGE vs OUTPUT CURRENT**

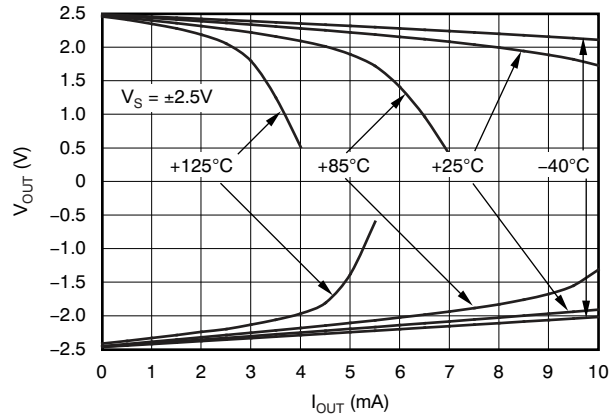

Figure 6.

**SHORT-CIRCUIT CURRENT vs SUPPLY VOLTAGE**

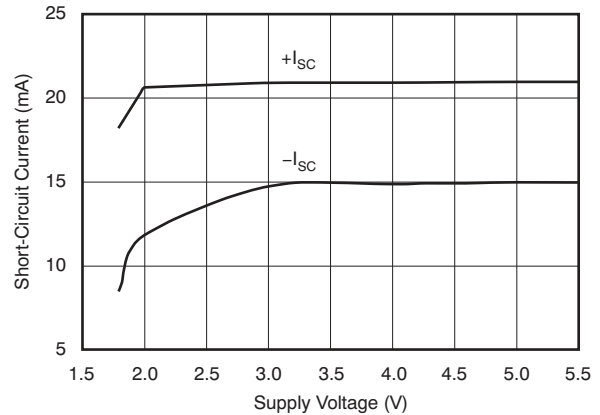

Figure 7.

**TYPICAL CHARACTERISTICS (continued)**

At  $T_A = +25^\circ\text{C}$ ,  $V_S = 5\text{V}$ , and  $R_L = 25\text{k}\Omega$  connected to  $V_S/2$ , unless otherwise noted.

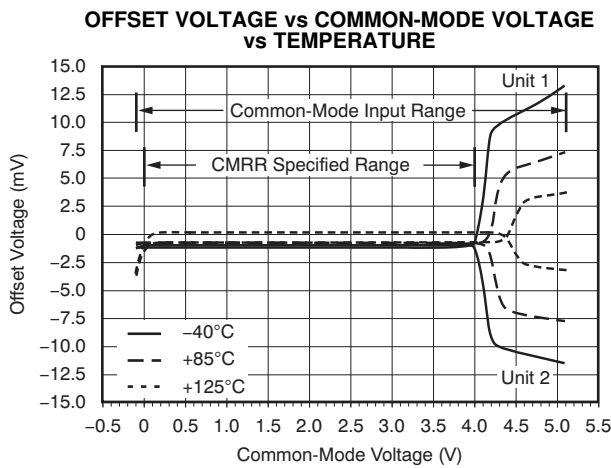

Figure 8.

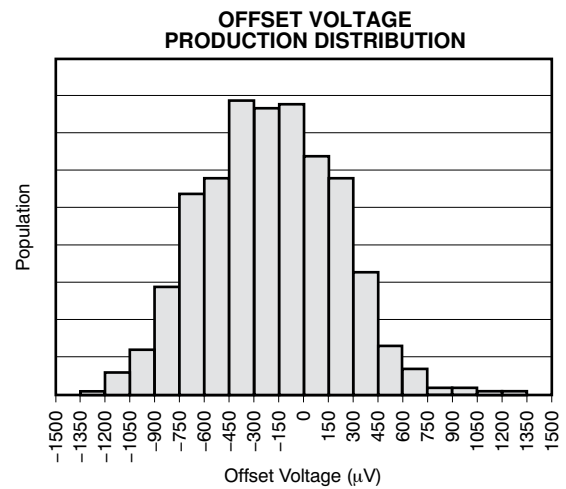

Figure 9.

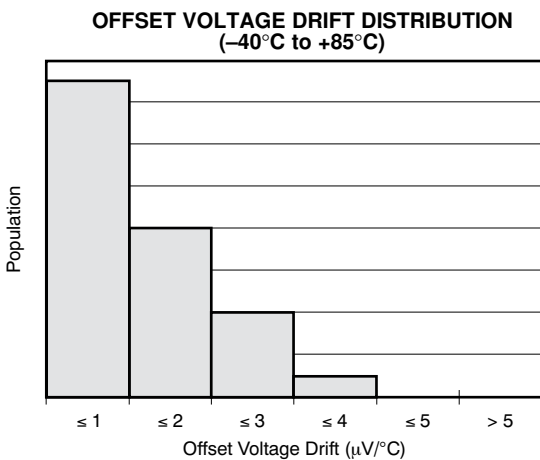

Figure 10.

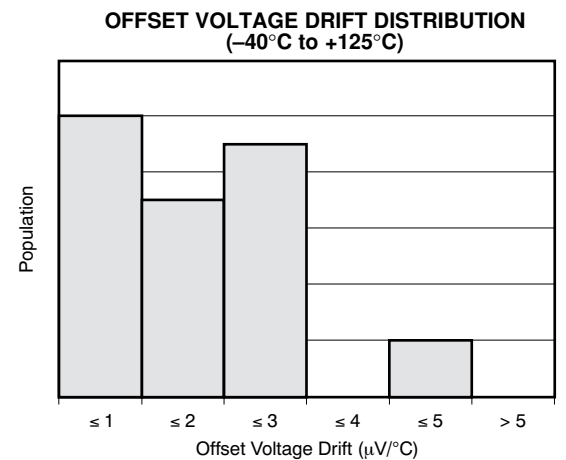

Figure 11.

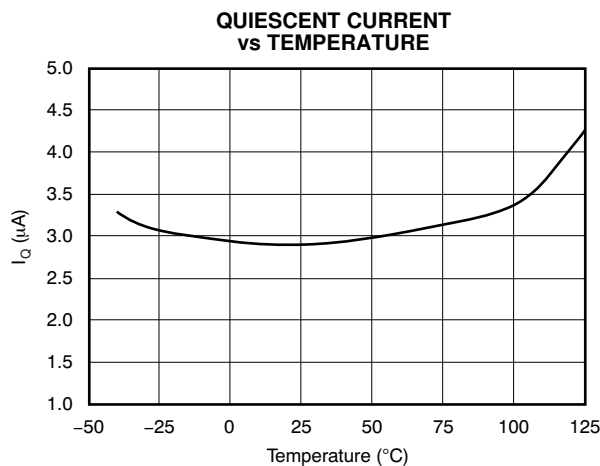

Figure 12.

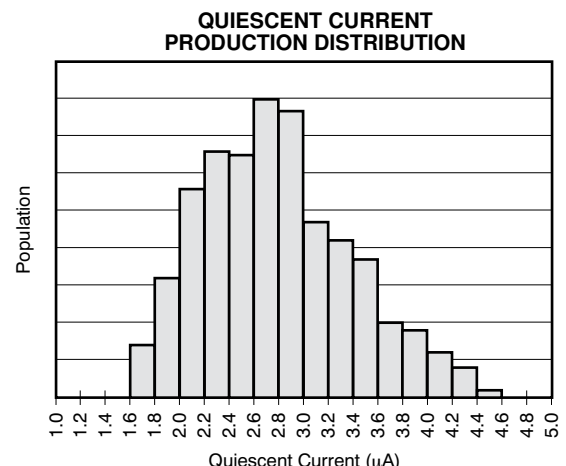

Figure 13.

**TYPICAL CHARACTERISTICS (continued)**

At  $T_A = +25^\circ\text{C}$ ,  $V_S = 5\text{V}$ , and  $R_L = 25\text{k}\Omega$  connected to  $V_S/2$ , unless otherwise noted.

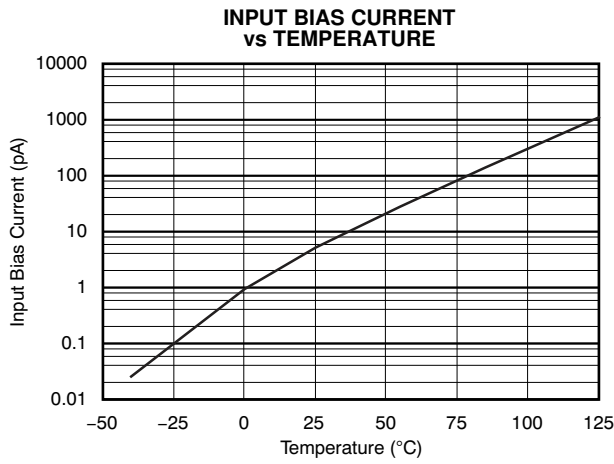

Figure 14.

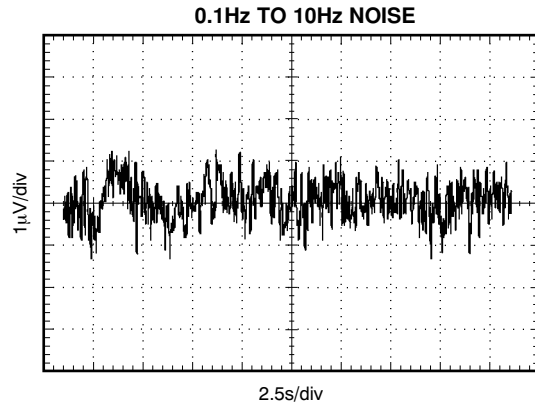

Figure 15.

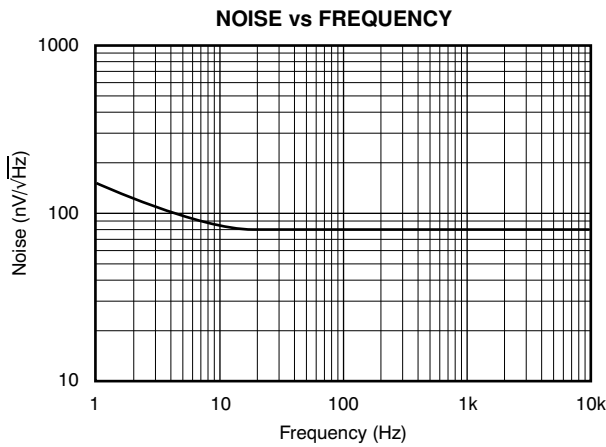

Figure 16.

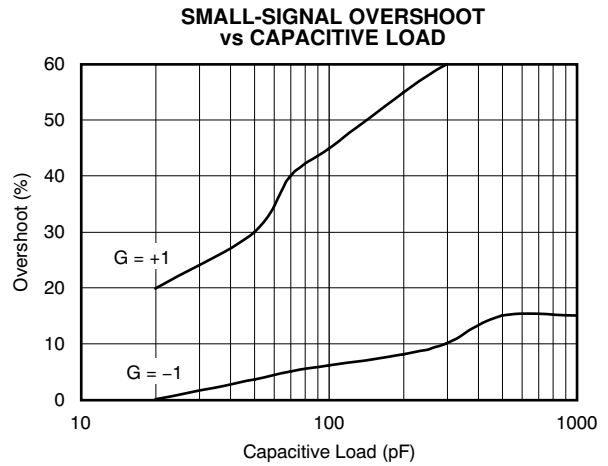

Figure 17.

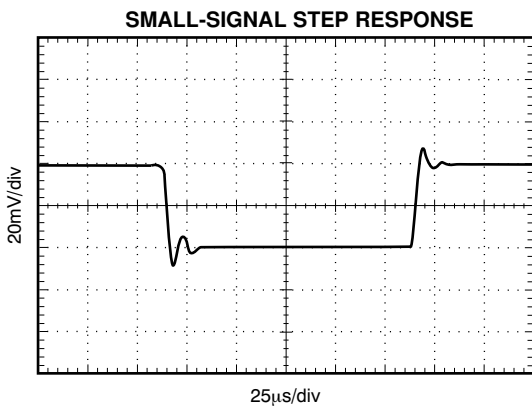

Figure 18.

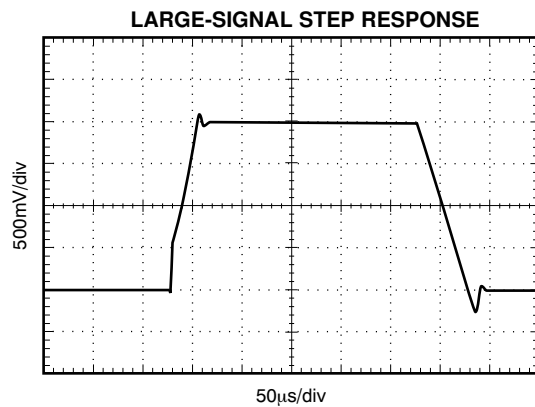

Figure 19.



## APPLICATION INFORMATION

The OPA379 family of operational amplifiers minimizes power consumption without compromising bandwidth or noise. Power-supply rejection ratio (PSRR), common-mode rejection ratio (CMRR), and open-loop gain ( $A_{OL}$ ) typical values are 100dB or better.

When designing for ultra-low power, choose system components carefully. To minimize current consumption, select large-value resistors. Any resistors will react with stray capacitance in the circuit and the input capacitance of the operational amplifier. These parasitic RC combinations can affect the stability of the overall system. A feedback capacitor may be required to assure stability and limit overshoot or gain peaking.

Good layout practice mandates the use of a 0.1 $\mu$ F bypass capacitor placed closely across the supply pins.

### OPERATING VOLTAGE

OPA379 series op amps are fully specified and tested from +1.8V to +5.5V ( $\pm 0.9$ V to  $\pm 2.75$ V). Parameters that will vary with supply voltage are shown in the [Typical Characteristics](#) curves.

### INPUT COMMON-MODE VOLTAGE RANGE

The input common-mode voltage range of the OPA379 family typically extends 100mV beyond each supply rail. This rail-to-rail input is achieved using a complementary input stage. CMRR is specified from the negative rail to 1V below the positive rail. Between  $(V_+) - 1$ V and  $(V_+) + 0.1$ V, the amplifier operates with higher offset voltage because of the transition region of the input stage. See the typical characteristic, *Offset Voltage vs Common-Mode Voltage vs Temperature* ([Figure 8](#)).

### PROTECTING INPUTS FROM OVER-VOLTAGE

Normally, input currents are 5pA. However, a large voltage input (greater than 500mV beyond the supply rails) can cause excessive current to flow in or out of the input pins. Therefore, as well as keeping the input voltage below the maximum rating, it is also important to limit the input current to less than 10mA. This limiting is easily accomplished with an input voltage resistor, as shown in [Figure 20](#).

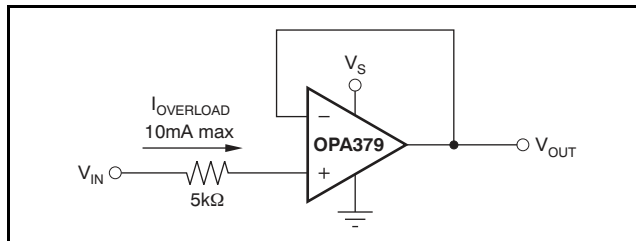

**Figure 20. Input Current Protection for Voltages Exceeding the Supply Voltage**

### NOISE

Although micropower amplifiers frequently have high wideband noise, the OPA379 series offer excellent noise performance. Resistors should be chosen carefully because the OPA379 has only 2.8 $\mu$ V<sub>PP</sub> of 0.1Hz to 10Hz noise, and 80nV/ $\sqrt{\text{Hz}}$  of wideband noise; otherwise, they can become the dominant source of noise.

### CAPACITIVE LOAD AND STABILITY

Follower configurations with load capacitance in excess of 30pF can produce extra overshoot (see typical characteristic *Small-Signal Overshoot vs Capacitive Load*, [Figure 17](#)) and ringing in the output signal. Increasing the gain enhances the ability of the amplifier to drive greater capacitive loads. In unity-gain configurations, capacitive load drive can be improved by inserting a small (10 $\Omega$  to 20 $\Omega$ ) resistor,  $R_S$ , in series with the output, as shown in [Figure 21](#). This resistor significantly reduces ringing while maintaining direct current (dc) performance for purely capacitive loads. However, if there is a resistive load in parallel with the capacitive load, a voltage divider is created, introducing a dc error at the output and slightly reducing the output swing. The error introduced is proportional to the ratio  $R_S/R_L$ , and is generally negligible.

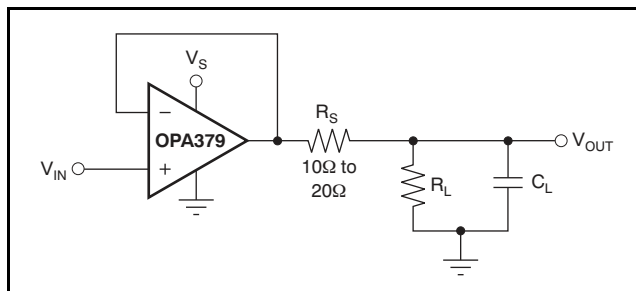

**Figure 21. Series Resistor in Unity-Gain Buffer Configuration Improves Capacitive Load Drive**

In unity-gain inverter configuration, phase margin can be reduced by the reaction between the capacitance at the op amp input and the gain setting resistors. Best performance is achieved by using smaller valued resistors. However, when large valued resistors cannot be avoided, a small (4pF to 6pF) capacitor,  $C_{FB}$ , can be inserted in the feedback, as shown in Figure 22. This configuration significantly reduces overshoot by compensating the effect of capacitance,  $C_{IN}$ , which includes the amplifier input capacitance (3pf) and printed circuit board (PC) parasitic capacitance.

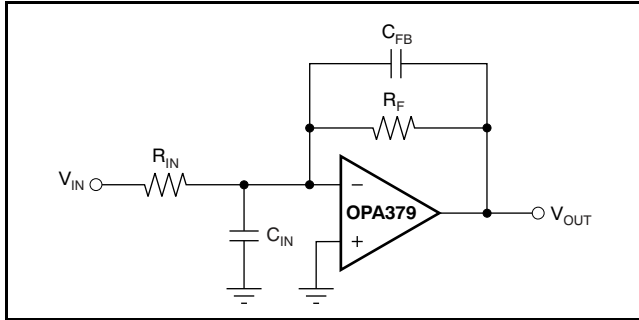

Figure 22. Improving Stability for Large  $R_F$  and  $R_{IN}$

## BATTERY MONITORING

The low operating voltage and quiescent current of the OPA379 series make it an excellent choice for battery monitoring applications, as shown in Figure 23. In this circuit,  $V_{STATUS}$  is high as long as the battery voltage remains above 2V. A low-power reference is used to set the trip point. Resistor values are selected as follows:

1.  $R_F$  Selecting: Select  $R_F$  such that the current through  $R_F$  is approximately 1000x larger than the maximum bias current over temperature:

$$\begin{aligned} R_F &= \frac{V_{REF}}{1000(I_{BMAX})} \\ &= \frac{1.2V}{1000(100pA)} \\ &= 12M\Omega \approx 10M\Omega \end{aligned} \quad (1)$$

2. Choose the hysteresis voltage,  $V_{HYST}$ . For battery monitoring applications, 50mV is adequate.

3. Calculate  $R_1$  as follows:

$$R_1 = R_F \left[ \frac{V_{HYST}}{V_{BATT}} \right] = 10M\Omega \left[ \frac{50mV}{2.4V} \right] = 210k\Omega \quad (2)$$

4. Select a threshold voltage for  $V_{IN}$  rising ( $V_{THRS}$ ) = 2.0V

5. Calculate  $R_2$  as follows:

$$\begin{aligned} R_2 &= \frac{1}{\left[ \left( \frac{V_{THRS}}{V_{REF} \times R_1} \right) - \frac{1}{R_1} - \frac{1}{R_F} \right]} \\ &= \frac{1}{\left[ \left( \frac{2V}{1.2V \times 210k\Omega} \right) - \frac{1}{210k\Omega} - \frac{1}{10M\Omega} \right]} \\ &= 325k\Omega \end{aligned} \quad (3)$$

6. Calculate  $R_{BIAS}$ : The minimum supply voltage for this circuit is 1.8V. The REF1112 has a current requirement of 1.2 $\mu$ A (max). Providing 2 $\mu$ A of supply current assures proper operation. Therefore:

$$R_{BIAS} = \frac{(V_{BATTMIN} - V_{REF})}{I_{BIAS}} = \frac{(1.8V - 1.2V)}{2\mu A} = 0.3M\Omega \quad (4)$$

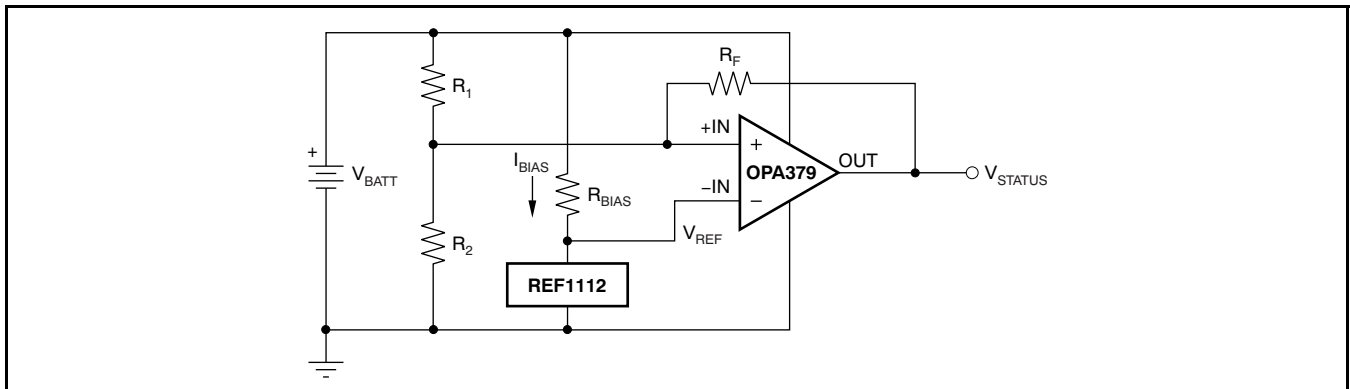

Figure 23. Battery Monitor

## WINDOW COMPARATOR

Figure 24 shows the OPA2379 used as a window comparator. The threshold limits are set by  $V_H$  and  $V_L$ , with  $V_H > V_L$ . When  $V_{IN} < V_H$ , the output of A1 is low. When  $V_{IN} > V_L$ , the output of A2 is low. Therefore, both op amp outputs are at 0V as long as  $V_{IN}$  is between  $V_H$  and  $V_L$ . This architecture results in no current flowing through either diode, Q1 in cutoff, with the base voltage at 0V, and  $V_{OUT}$  forced high.

If  $V_{IN}$  falls below  $V_L$ , the output of A2 is high, current flows through D2, and  $V_{OUT}$  is low. Likewise, if  $V_{IN}$  rises above  $V_H$ , the output of A1 is high, current flows through D1, and  $V_{OUT}$  is low.

The window comparator threshold voltages are set as follows:

$$V_H = \frac{R_2}{R_1 + R_2} \times V_S \quad (5)$$

$$V_L = \frac{R_4}{R_3 + R_4} \times V_S \quad (6)$$

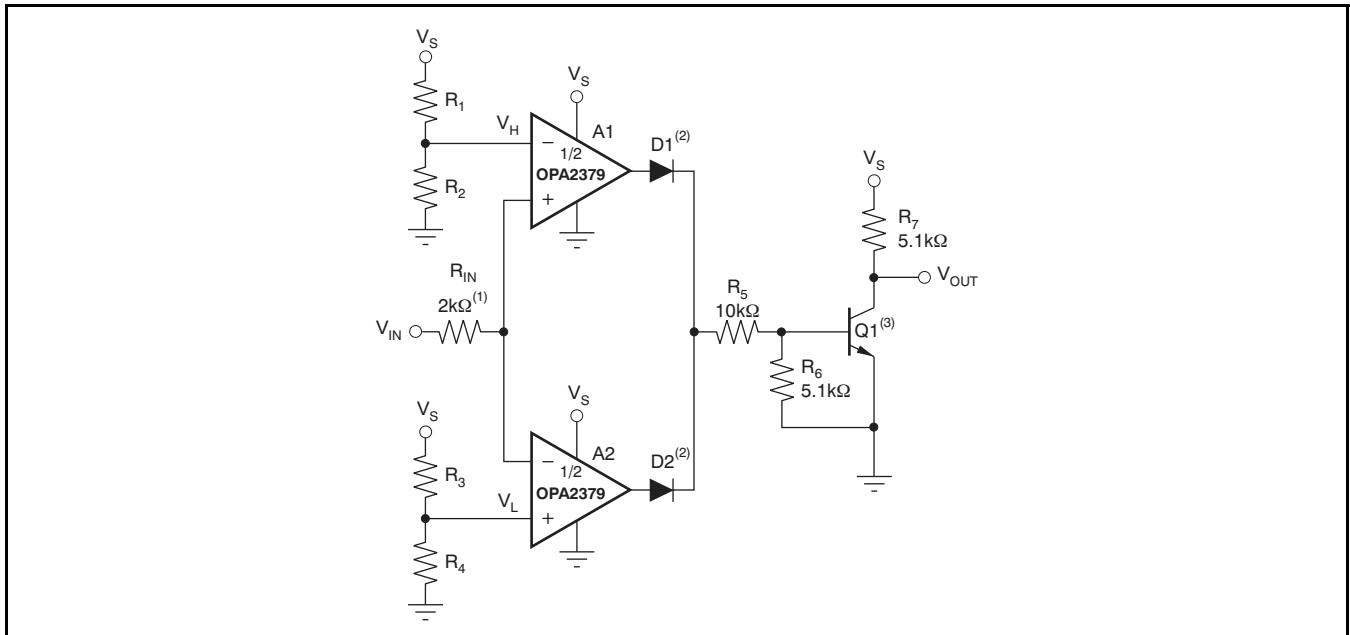

- (1)  $R_{IN}$  protects A1 and A2 from possible excess current flow.
- (2) IN4446 or equivalent diodes.
- (3) 2N2222 or equivalent NPN transistor.

**Figure 24. OPA2379 as a Window Comparator**

## ADDITIONAL APPLICATION EXAMPLES

Figure 25 through Figure 29 illustrate additional application examples.

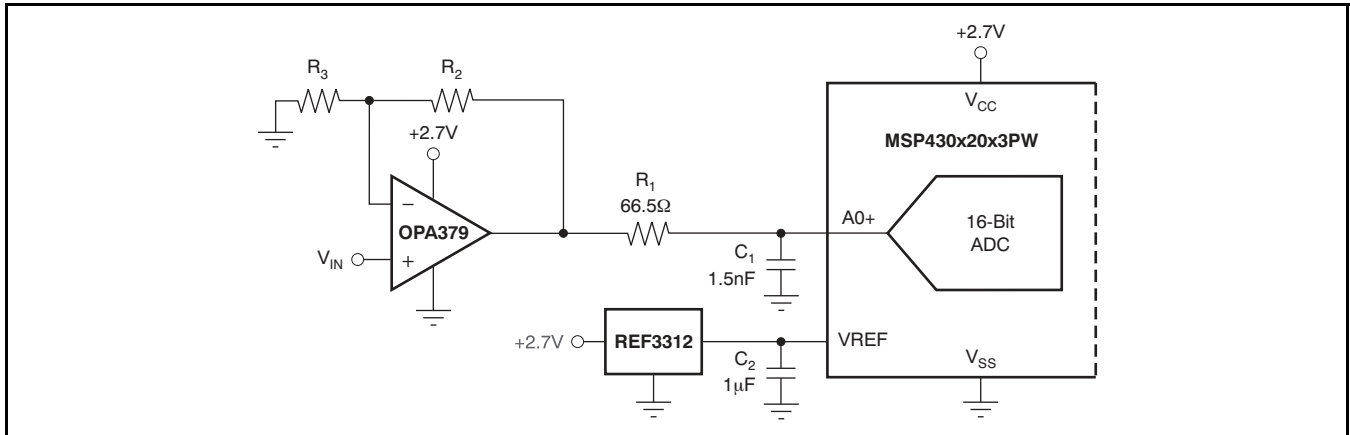

Figure 25. Unipolar Signal Chain Configuration

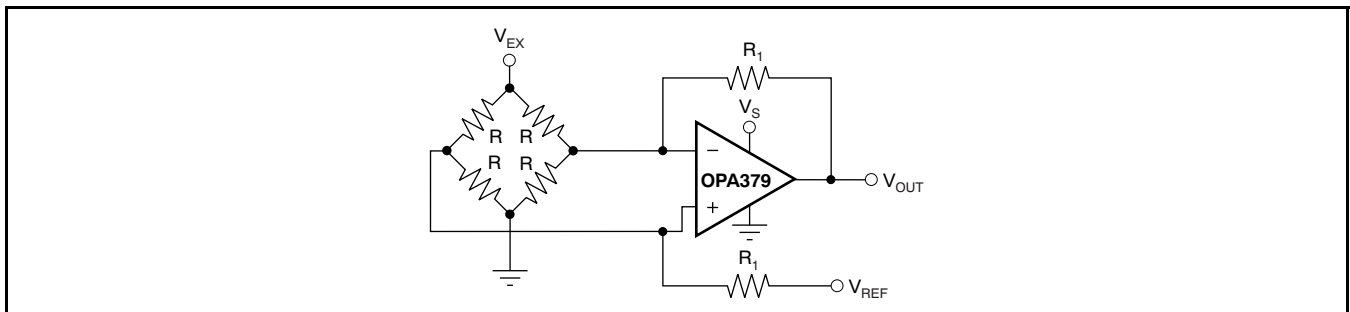
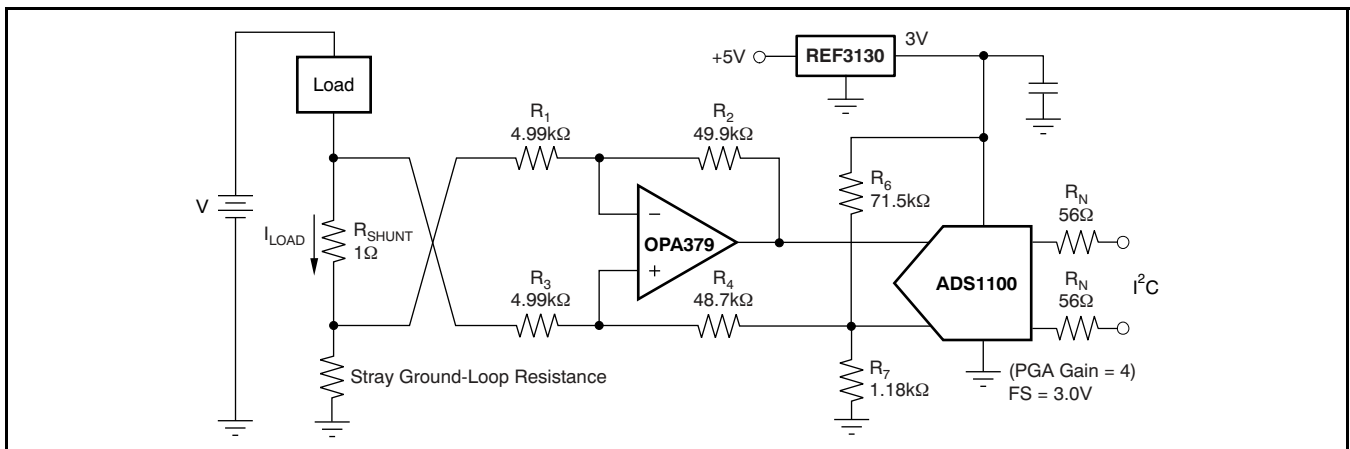
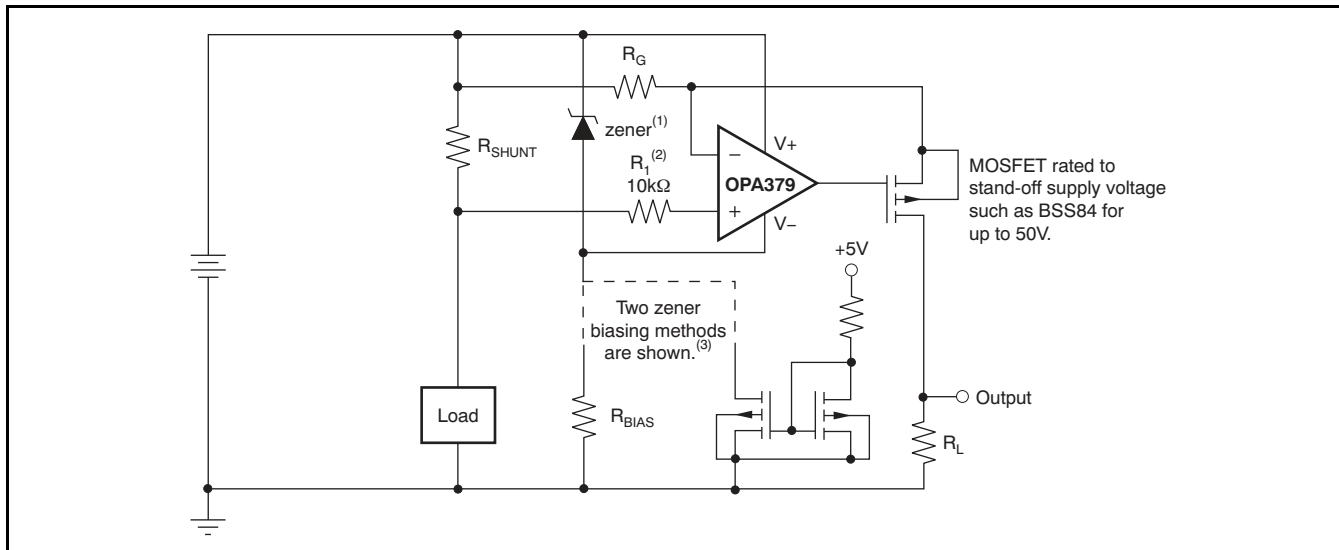

Figure 26. Single Op Amp Bridge Amplifier



NOTE: 1% resistors provide adequate common-mode rejection at small ground-loop errors.

Figure 27. Low-Side Current Monitor



- (1) Zener rated for op amp supply capability (that is, 5.1V for OPA379).
- (2) Current-limiting resistor.
- (3) Choose zener biasing resistor or dual NMOSMETs (FDG6301N, NTJD4001N, or Si1034).

**Figure 28. High-Side Current Monitor**

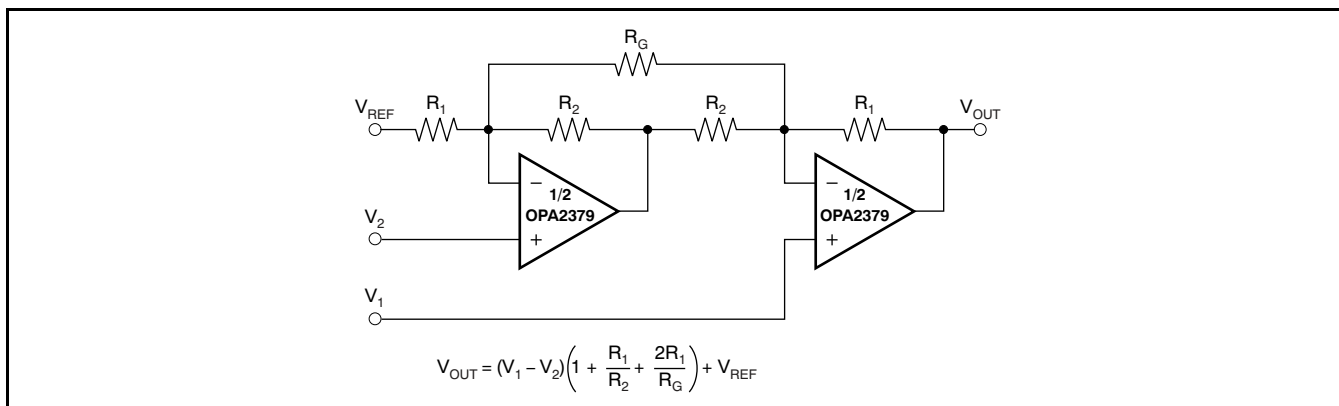

**Figure 29. Two Op Amp Instrumentation Amplifier**

**PACKAGING INFORMATION**

Orderable Device	Status (1)	Package Type	Package Drawing	Pins	Package Qty	Eco Plan (2)	Lead finish/ Ball material (6)	MSL Peak Temp (3)	Op Temp (°C)	Device Marking (4/5)	Samples
OPA2379AID	ACTIVE	SOIC	D	8	75	RoHS & Green	NIPDAU	Level-2-260C-1 YEAR	-40 to 125	2379A	<a href="#">Samples</a>
OPA2379AIDCNR	ACTIVE	SOT-23	DCN	8	3000	RoHS & Green	NIPDAU	Level-2-260C-1 YEAR	-40 to 125	BPK	<a href="#">Samples</a>
OPA2379AIDCNT	ACTIVE	SOT-23	DCN	8	250	RoHS & Green	NIPDAU	Level-2-260C-1 YEAR	-40 to 125	BPK	<a href="#">Samples</a>
OPA2379AIDG4	ACTIVE	SOIC	D	8	75	RoHS & Green	NIPDAU	Level-2-260C-1 YEAR	-40 to 125	2379A	<a href="#">Samples</a>
OPA2379AIDR	ACTIVE	SOIC	D	8	2500	RoHS & Green	NIPDAU	Level-2-260C-1 YEAR	-40 to 125	2379A	<a href="#">Samples</a>
OPA379AID	ACTIVE	SOIC	D	8	75	RoHS & Green	NIPDAU	Level-2-260C-1 YEAR	-40 to 125	OPA 379A	<a href="#">Samples</a>
OPA379AIDBVR	ACTIVE	SOT-23	DBV	5	3000	RoHS & Green	NIPDAU	Level-2-260C-1 YEAR	-40 to 125	B53	<a href="#">Samples</a>
OPA379AIDBVRG4	ACTIVE	SOT-23	DBV	5	3000	RoHS & Green	NIPDAU	Level-2-260C-1 YEAR	-40 to 125	B53	<a href="#">Samples</a>
OPA379AIDBVT	ACTIVE	SOT-23	DBV	5	250	RoHS & Green	NIPDAU	Level-2-260C-1 YEAR	-40 to 125	B53	<a href="#">Samples</a>
OPA379AIDCKR	ACTIVE	SC70	DCK	5	3000	RoHS & Green	NIPDAU	Level-2-260C-1 YEAR	-40 to 125	B54	<a href="#">Samples</a>
OPA379AIDCKT	ACTIVE	SC70	DCK	5	250	RoHS & Green	NIPDAU	Level-2-260C-1 YEAR	-40 to 125	B54	<a href="#">Samples</a>
OPA379AIDCKTG4	ACTIVE	SC70	DCK	5	250	RoHS & Green	NIPDAU	Level-2-260C-1 YEAR	-40 to 125	B54	<a href="#">Samples</a>
OPA379AIDR	ACTIVE	SOIC	D	8	2500	RoHS & Green	NIPDAU	Level-2-260C-1 YEAR	-40 to 125	OPA 379A	<a href="#">Samples</a>
OPA379AIDRG4	ACTIVE	SOIC	D	8	2500	RoHS & Green	NIPDAU	Level-2-260C-1 YEAR	-40 to 125	OPA 379A	<a href="#">Samples</a>
OPA4379AIPWR	ACTIVE	TSSOP	PW	14	2000	RoHS & Green	NIPDAU	Level-2-260C-1 YEAR	-40 to 125	4379A	<a href="#">Samples</a>

(1) The marketing status values are defined as follows:

**ACTIVE:** Product device recommended for new designs.

**LIFEBUY:** TI has announced that the device will be discontinued, and a lifetime-buy period is in effect.

**NRND:** Not recommended for new designs. Device is in production to support existing customers, but TI does not recommend using this part in a new design.

**PREVIEW:** Device has been announced but is not in production. Samples may or may not be available.

**OBSOLETE:** TI has discontinued the production of the device.

(2) **RoHS:** TI defines "RoHS" to mean semiconductor products that are compliant with the current EU RoHS requirements for all 10 RoHS substances, including the requirement that RoHS substance do not exceed 0.1% by weight in homogeneous materials. Where designed to be soldered at high temperatures, "RoHS" products are suitable for use in specified lead-free processes. TI may reference these types of products as "Pb-Free".

**RoHS Exempt:** TI defines "RoHS Exempt" to mean products that contain lead but are compliant with EU RoHS pursuant to a specific EU RoHS exemption.

**Green:** TI defines "Green" to mean the content of Chlorine (Cl) and Bromine (Br) based flame retardants meet JS709B low halogen requirements of  $\leq 1000$ ppm threshold. Antimony trioxide based flame retardants must also meet the  $\leq 1000$ ppm threshold requirement.

(3) MSL, Peak Temp. - The Moisture Sensitivity Level rating according to the JEDEC industry standard classifications, and peak solder temperature.

(4) There may be additional marking, which relates to the logo, the lot trace code information, or the environmental category on the device.

(5) Multiple Device Markings will be inside parentheses. Only one Device Marking contained in parentheses and separated by a "~" will appear on a device. If a line is indented then it is a continuation of the previous line and the two combined represent the entire Device Marking for that device.

(6) Lead finish/Ball material - Orderable Devices may have multiple material finish options. Finish options are separated by a vertical ruled line. Lead finish/Ball material values may wrap to two lines if the finish value exceeds the maximum column width.

**Important Information and Disclaimer:**The information provided on this page represents TI's knowledge and belief as of the date that it is provided. TI bases its knowledge and belief on information provided by third parties, and makes no representation or warranty as to the accuracy of such information. Efforts are underway to better integrate information from third parties. TI has taken and continues to take reasonable steps to provide representative and accurate information but may not have conducted destructive testing or chemical analysis on incoming materials and chemicals. TI and TI suppliers consider certain information to be proprietary, and thus CAS numbers and other limited information may not be available for release.

In no event shall TI's liability arising out of such information exceed the total purchase price of the TI part(s) at issue in this document sold by TI to Customer on an annual basis.

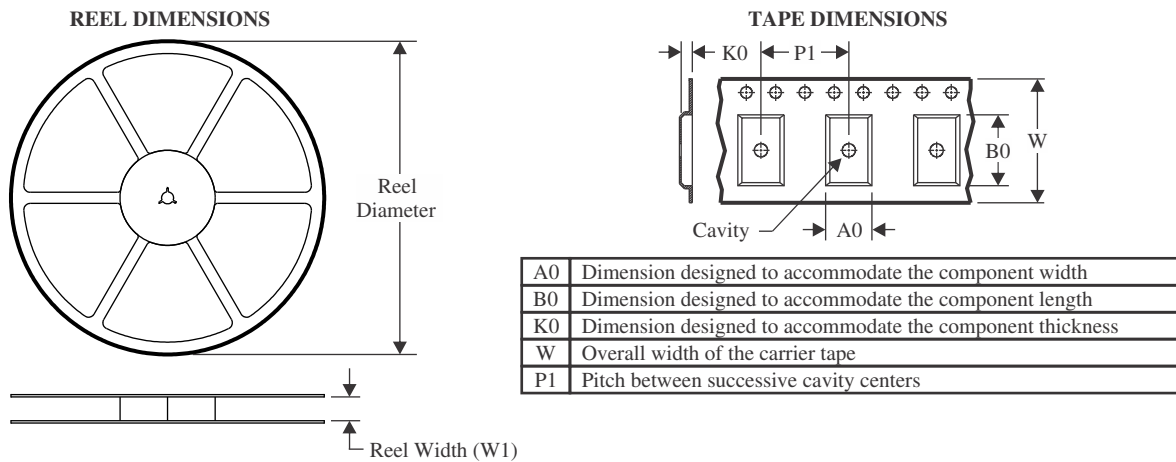
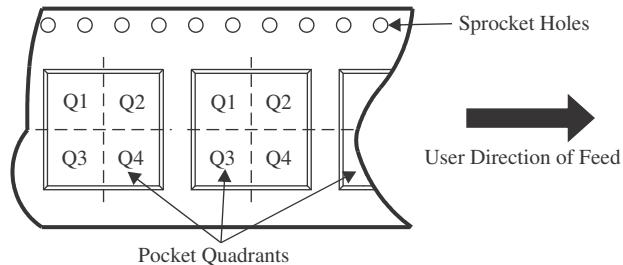
**TAPE AND REEL INFORMATION**

**QUADRANT ASSIGNMENTS FOR PIN 1 ORIENTATION IN TAPE**

\*All dimensions are nominal

Device	Package Type	Package Drawing	Pins	SPQ	Reel Diameter (mm)	Reel Width W1 (mm)	A0 (mm)	B0 (mm)	K0 (mm)	P1 (mm)	W (mm)	Pin1 Quadrant
OPA2379AIDCNR	SOT-23	DCN	8	3000	179.0	8.4	3.2	3.2	1.4	4.0	8.0	Q3
OPA2379AIDCNT	SOT-23	DCN	8	250	179.0	8.4	3.2	3.2	1.4	4.0	8.0	Q3
OPA2379AIDR	SOIC	D	8	2500	330.0	12.4	6.4	5.2	2.1	8.0	12.0	Q1
OPA379AIDBVR	SOT-23	DBV	5	3000	178.0	9.0	3.3	3.2	1.4	4.0	8.0	Q3
OPA379AIDBVT	SOT-23	DBV	5	250	178.0	9.0	3.3	3.2	1.4	4.0	8.0	Q3
OPA379AIDCKR	SC70	DCK	5	3000	179.0	8.4	2.2	2.5	1.2	4.0	8.0	Q3
OPA379AIDCKR	SC70	DCK	5	3000	178.0	9.0	2.4	2.5	1.2	4.0	8.0	Q3
OPA379AIDCKT	SC70	DCK	5	250	179.0	8.4	2.2	2.5	1.2	4.0	8.0	Q3
OPA379AIDCKT	SC70	DCK	5	250	178.0	9.0	2.4	2.5	1.2	4.0	8.0	Q3
OPA379AIDR	SOIC	D	8	2500	330.0	12.4	6.4	5.2	2.1	8.0	12.0	Q1
OPA4379AIPWR	TSSOP	PW	14	2000	330.0	12.4	6.9	5.6	1.6	8.0	12.0	Q1

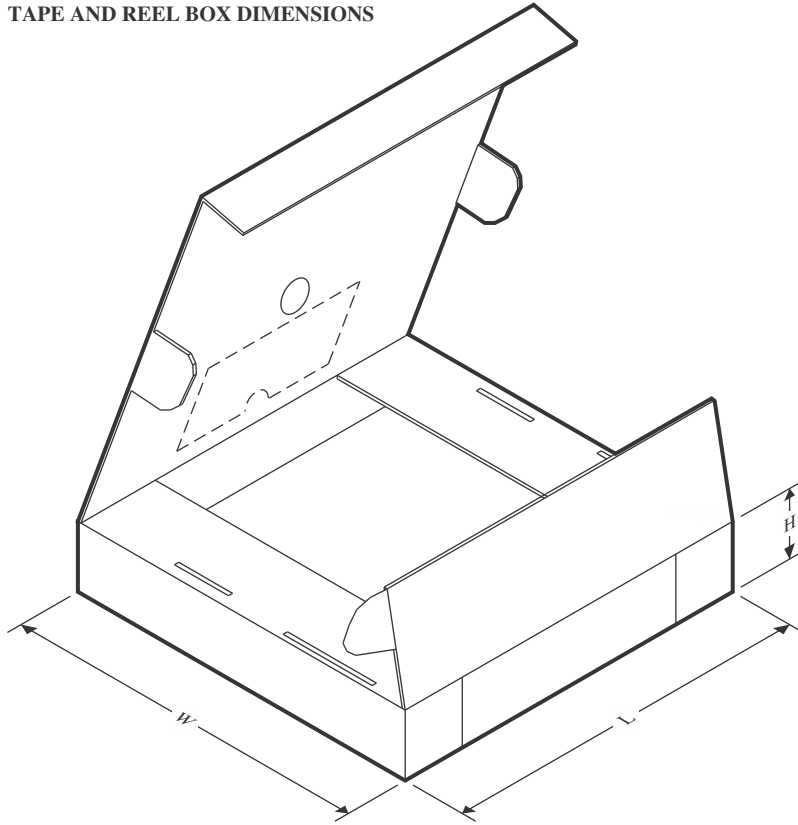

## TAPE AND REEL BOX DIMENSIONS



\*All dimensions are nominal

Device	Package Type	Package Drawing	Pins	SPQ	Length (mm)	Width (mm)	Height (mm)
OPA2379AIDCNR	SOT-23	DCN	8	3000	213.0	191.0	35.0
OPA2379AIDCNT	SOT-23	DCN	8	250	213.0	191.0	35.0
OPA2379AIDR	SOIC	D	8	2500	356.0	356.0	35.0
OPA379AIDBVR	SOT-23	DBV	5	3000	180.0	180.0	18.0
OPA379AIDBVT	SOT-23	DBV	5	250	180.0	180.0	18.0
OPA379AIDCKR	SC70	DCK	5	3000	213.0	191.0	35.0
OPA379AIDCKR	SC70	DCK	5	3000	190.0	190.0	30.0
OPA379AIDCKT	SC70	DCK	5	250	213.0	191.0	35.0
OPA379AIDCKT	SC70	DCK	5	250	190.0	190.0	30.0
OPA379AIDR	SOIC	D	8	2500	356.0	356.0	35.0
OPA4379AIPWR	TSSOP	PW	14	2000	356.0	356.0	35.0

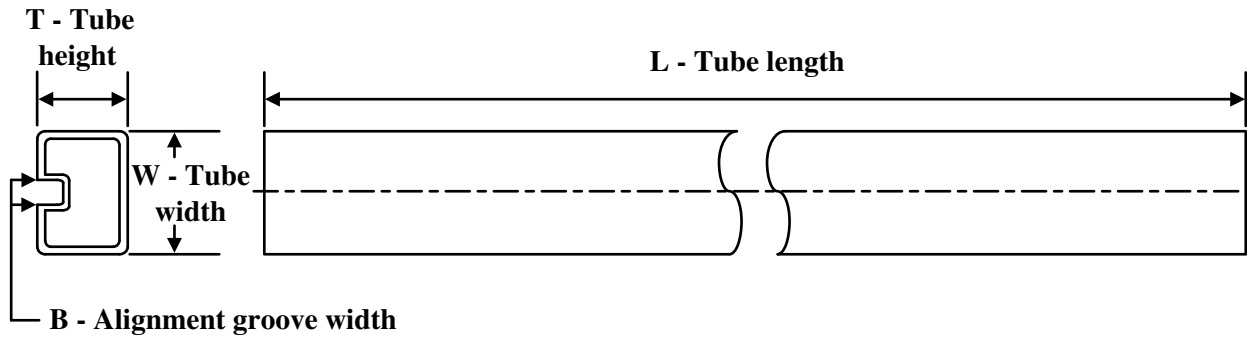
**TUBE**

\*All dimensions are nominal

Device	Package Name	Package Type	Pins	SPQ	L (mm)	W (mm)	T (μm)	B (mm)
OPA2379AID	D	SOIC	8	75	506.6	8	3940	4.32
OPA2379AIDG4	D	SOIC	8	75	506.6	8	3940	4.32
OPA379AID	D	SOIC	8	75	506.6	8	3940	4.32

DCN (R-PDSO-G8)

PLASTIC SMALL-OUTLINE PACKAGE (DIE DOWN)

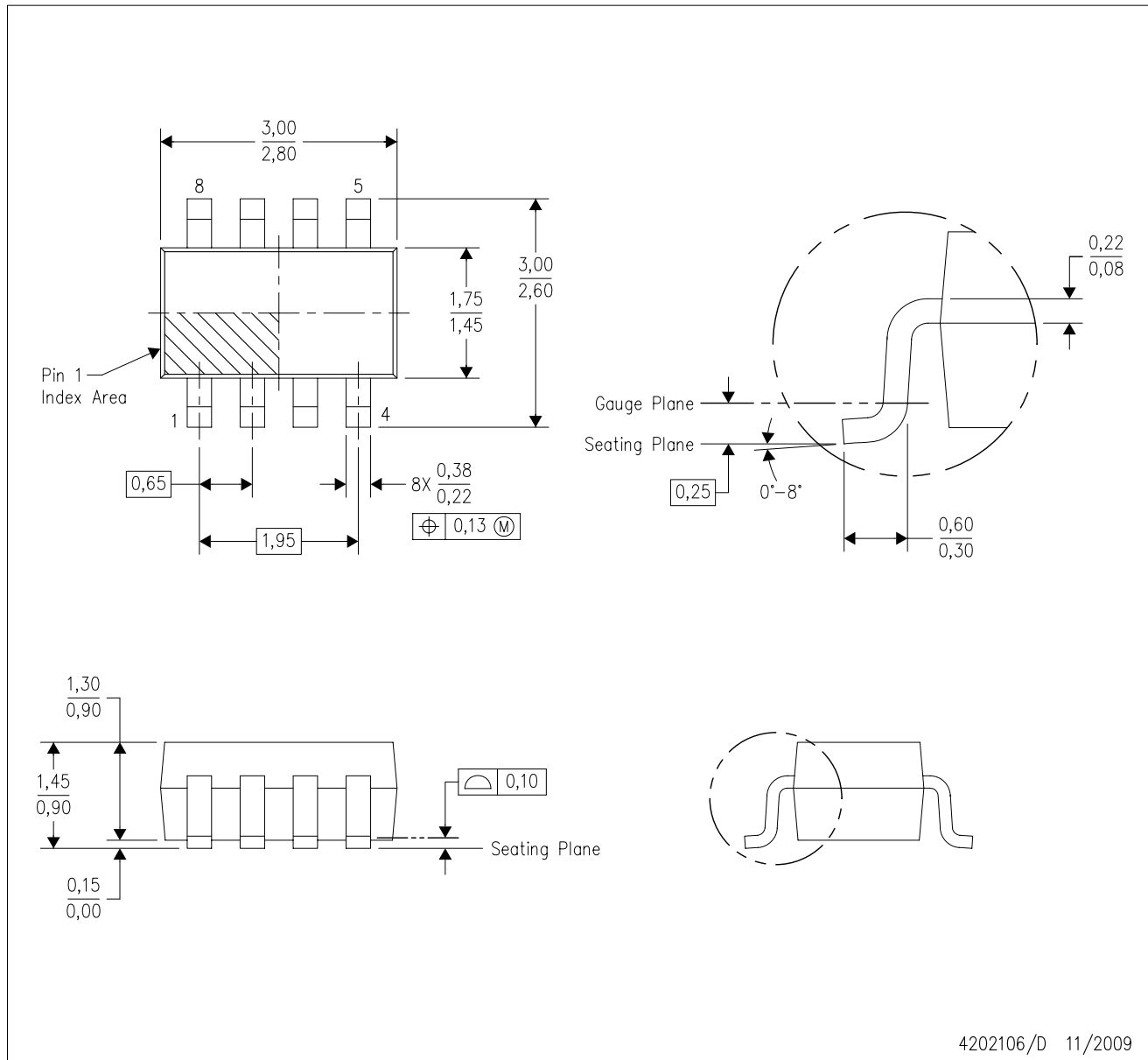

- NOTES:
- A. All linear dimensions are in millimeters.
  - B. This drawing is subject to change without notice.
  - C. Package outline exclusive of metal burr & dambar protrusion/intrusion.
  - D. Package outline inclusive of solder plating.
  - E. A visual index feature must be located within the Pin 1 index area.
  - F. Falls within JEDEC MO-178 Variation BA.
  - G. Body dimensions do not include flash or protrusion. Mold flash and protrusion shall not exceed 0.25 per side.

DCN (R-PDSO-G8)

PLASTIC SMALL-OUTLINE PACKAGE (DIE DOWN)

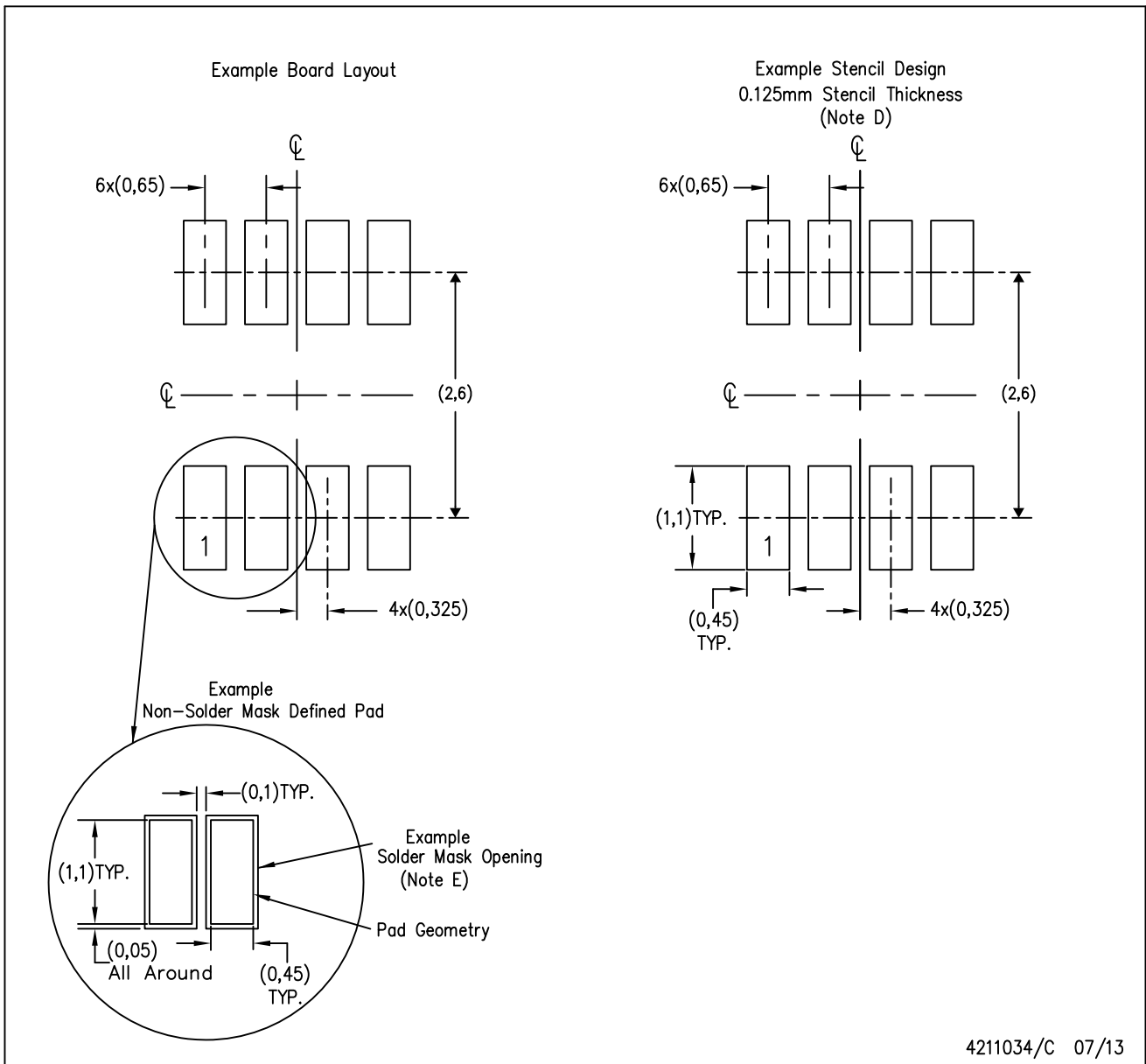

- NOTES:
- A. All linear dimensions are in millimeters.
  - B. This drawing is subject to change without notice.
  - C. Publication IPC-7351 is recommended for alternate designs.
  - D. Laser cutting apertures with trapezoidal walls and also rounding corners will offer better paste release. Customers should contact their board assembly site for stencil design recommendations. Refer to IPC-7525.
  - E. Customers should contact their board fabrication site for solder mask tolerances between and around signal pads.



# EXAMPLE BOARD LAYOUT

DBV0005A

SOT-23 - 1.45 mm max height

SMALL OUTLINE TRANSISTOR

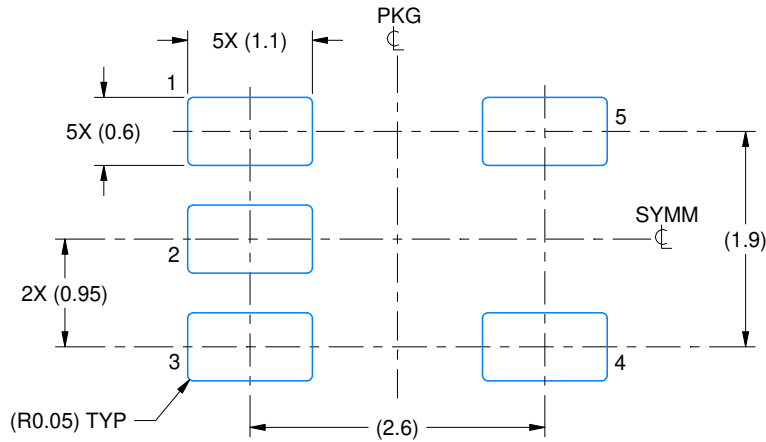

LAND PATTERN EXAMPLE  
EXPOSED METAL SHOWN  
SCALE:15X

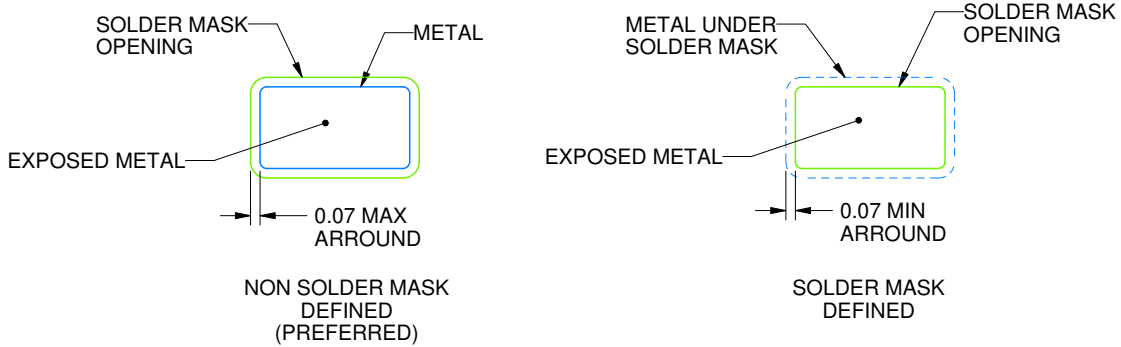

SOLDER MASK DETAILS

4214839/H 09/2023

NOTES: (continued)

- 6. Publication IPC-7351 may have alternate designs.
- 7. Solder mask tolerances between and around signal pads can vary based on board fabrication site.

# EXAMPLE STENCIL DESIGN

DBV0005A

SOT-23 - 1.45 mm max height

SMALL OUTLINE TRANSISTOR

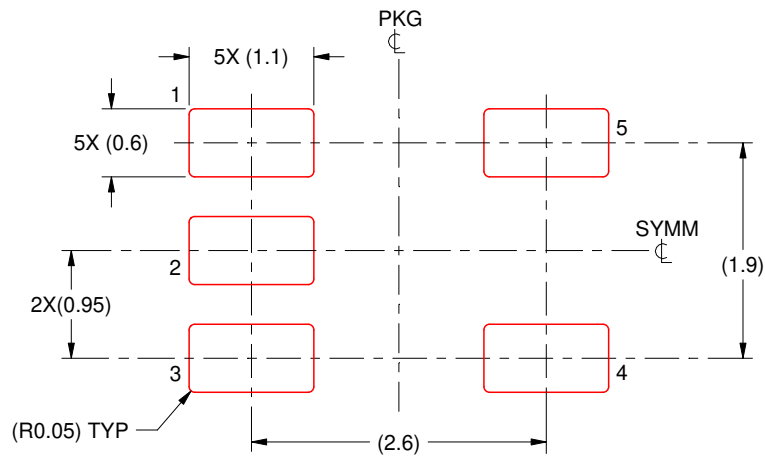

SOLDER PASTE EXAMPLE  
BASED ON 0.125 mm THICK STENCIL  
SCALE:15X

4214839/H 09/2023

NOTES: (continued)

8. Laser cutting apertures with trapezoidal walls and rounded corners may offer better paste release. IPC-7525 may have alternate design recommendations.
9. Board assembly site may have different recommendations for stencil design.

PW (R-PDSO-G14)

PLASTIC SMALL OUTLINE

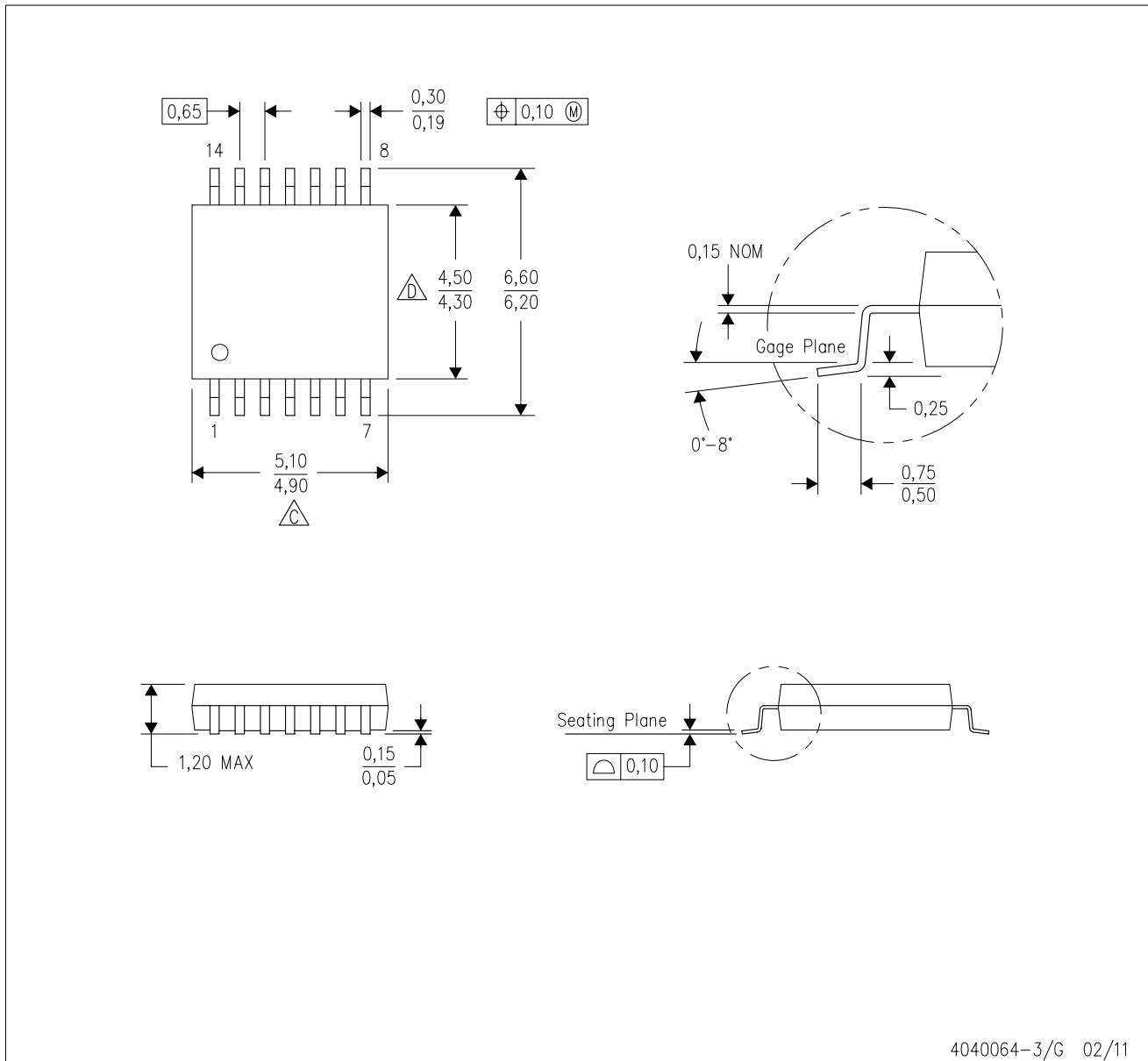

4040064-3/G 02/11

- NOTES:
- A. All linear dimensions are in millimeters. Dimensioning and tolerancing per ASME Y14.5M-1994.
  - B. This drawing is subject to change without notice.
  - C. Body length does not include mold flash, protrusions, or gate burrs. Mold flash, protrusions, or gate burrs shall not exceed 0,15 each side.
  - D. Body width does not include interlead flash. Interlead flash shall not exceed 0,25 each side.
  - E. Falls within JEDEC MO-153



PW (R-PDSO-G14)

PLASTIC SMALL OUTLINE

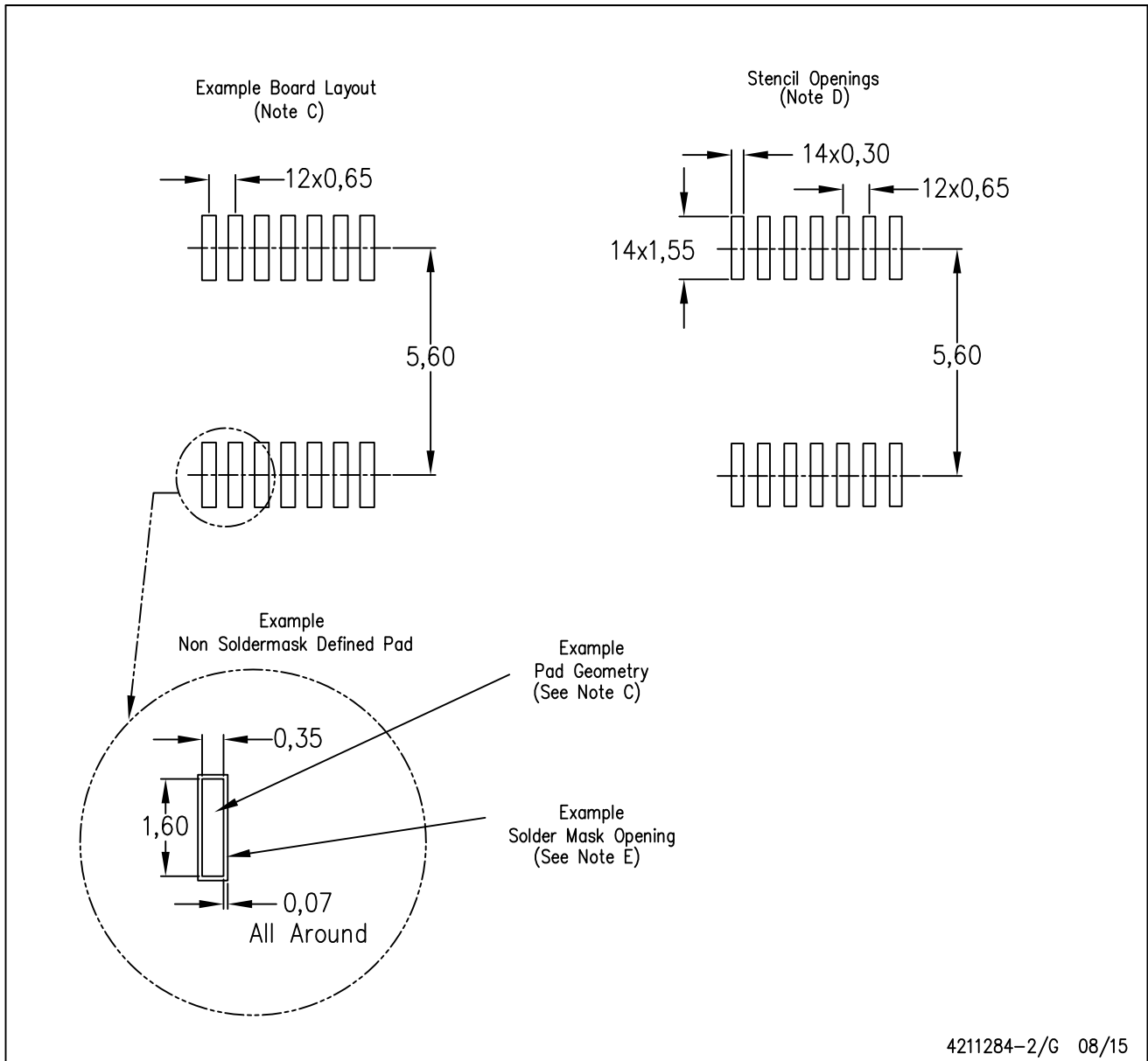

- NOTES:
- All linear dimensions are in millimeters.
  - This drawing is subject to change without notice.
  - Publication IPC-7351 is recommended for alternate designs.
  - Laser cutting apertures with trapezoidal walls and also rounding corners will offer better paste release. Customers should contact their board assembly site for stencil design recommendations. Refer to IPC-7525 for other stencil recommendations.
  - Customers should contact their board fabrication site for solder mask tolerances between and around signal pads.



D0008A

# PACKAGE OUTLINE

SOIC - 1.75 mm max height

SMALL OUTLINE INTEGRATED CIRCUIT

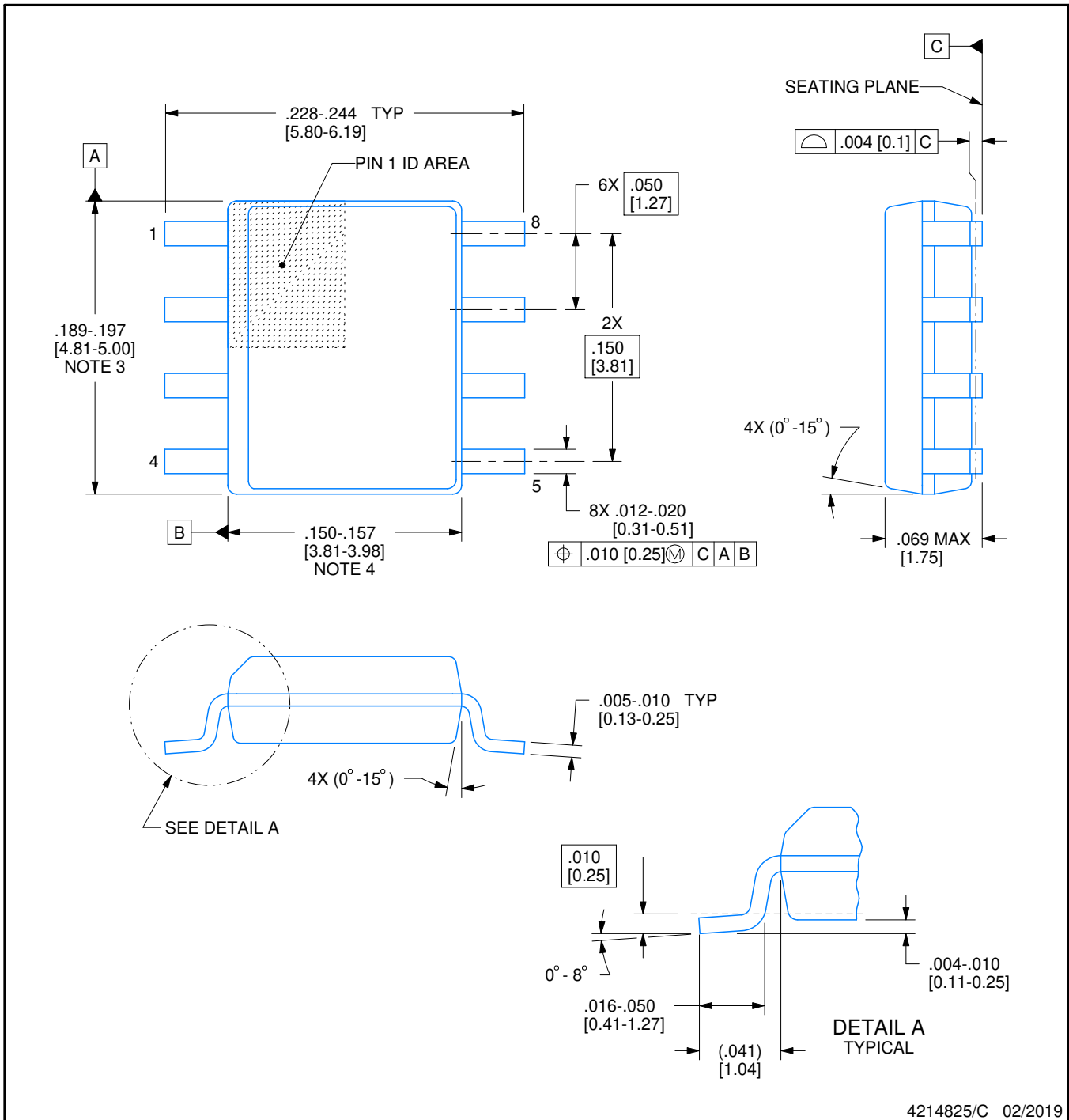

### NOTES:

1. Linear dimensions are in inches [millimeters]. Dimensions in parenthesis are for reference only. Controlling dimensions are in inches. Dimensioning and tolerancing per ASME Y14.5M.
2. This drawing is subject to change without notice.
3. This dimension does not include mold flash, protrusions, or gate burrs. Mold flash, protrusions, or gate burrs shall not exceed .006 [0.15] per side.
4. This dimension does not include interlead flash.
5. Reference JEDEC registration MS-012, variation AA.

# EXAMPLE BOARD LAYOUT

D0008A

SOIC - 1.75 mm max height

SMALL OUTLINE INTEGRATED CIRCUIT



LAND PATTERN EXAMPLE  
EXPOSED METAL SHOWN  
SCALE:8X



SOLDER MASK DETAILS

4214825/C 02/2019

NOTES: (continued)

- 6. Publication IPC-7351 may have alternate designs.
- 7. Solder mask tolerances between and around signal pads can vary based on board fabrication site.

# EXAMPLE STENCIL DESIGN

D0008A

SOIC - 1.75 mm max height

SMALL OUTLINE INTEGRATED CIRCUIT



SOLDER PASTE EXAMPLE  
BASED ON .005 INCH [0.125 MM] THICK STENCIL  
SCALE:8X

4214825/C 02/2019

NOTES: (continued)

8. Laser cutting apertures with trapezoidal walls and rounded corners may offer better paste release. IPC-7525 may have alternate design recommendations.
9. Board assembly site may have different recommendations for stencil design.



# PACKAGE OUTLINE

## DCK0005A

### SOT - 1.1 max height

SMALL OUTLINE TRANSISTOR

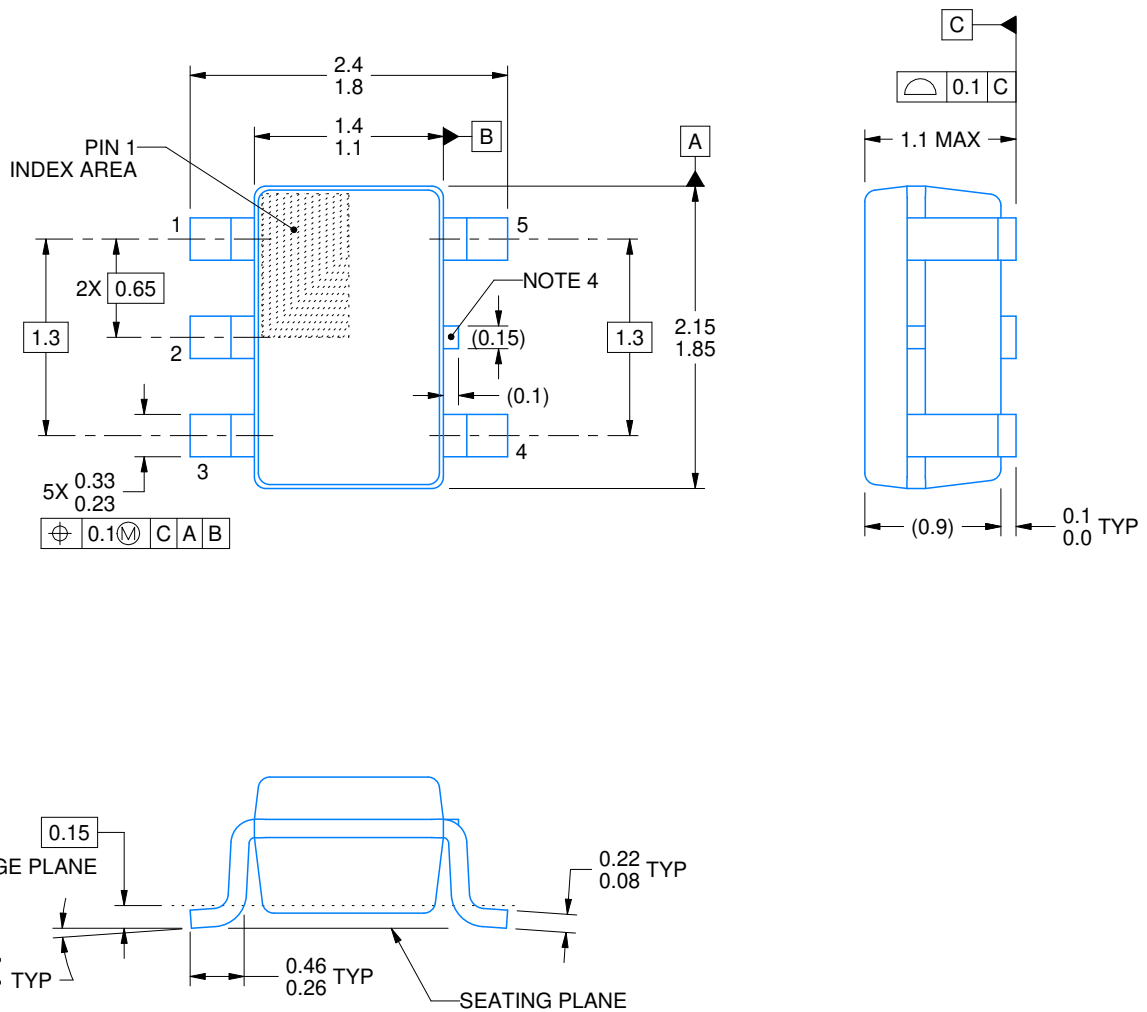

4214834/C 03/2023

#### NOTES:

1. All linear dimensions are in millimeters. Any dimensions in parenthesis are for reference only. Dimensioning and tolerancing per ASME Y14.5M.
2. This drawing is subject to change without notice.
3. Reference JEDEC MO-203.
4. Support pin may differ or may not be present.

# EXAMPLE BOARD LAYOUT

DCK0005A

SOT - 1.1 max height

SMALL OUTLINE TRANSISTOR

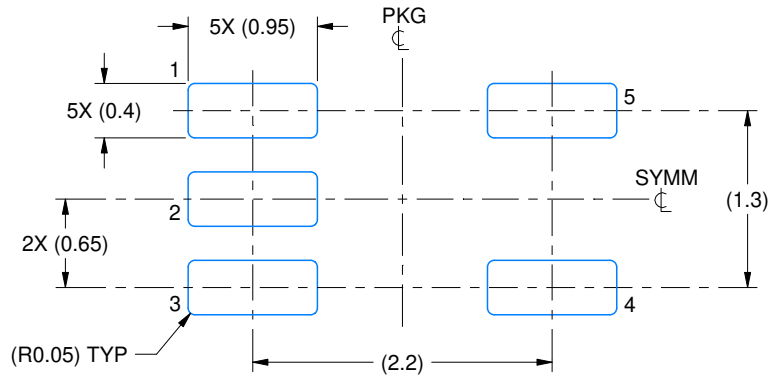

LAND PATTERN EXAMPLE  
EXPOSED METAL SHOWN  
SCALE:18X

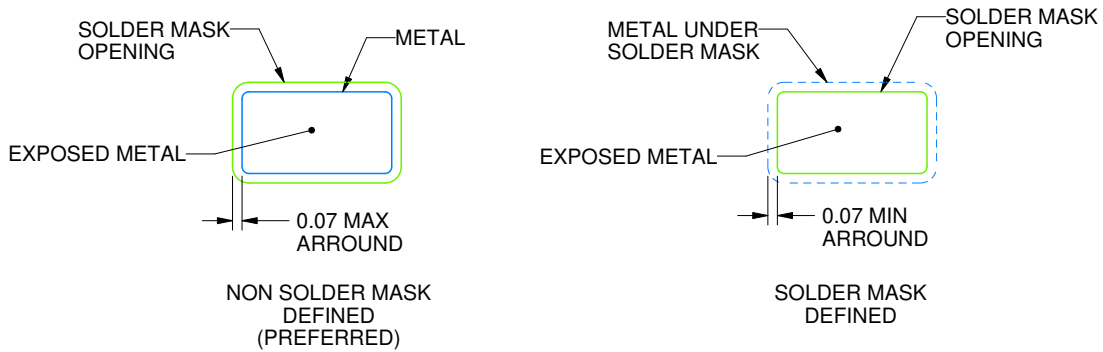

SOLDER MASK DETAILS

4214834/C 03/2023

NOTES: (continued)

- 4. Publication IPC-7351 may have alternate designs.
- 5. Solder mask tolerances between and around signal pads can vary based on board fabrication site.

# EXAMPLE STENCIL DESIGN

DCK0005A

SOT - 1.1 max height

SMALL OUTLINE TRANSISTOR

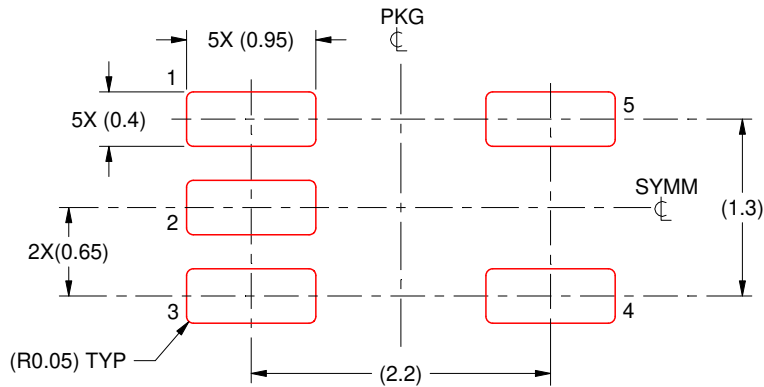

SOLDER PASTE EXAMPLE  
BASED ON 0.125 THICK STENCIL  
SCALE:18X

4214834/C 03/2023

NOTES: (continued)

6. Laser cutting apertures with trapezoidal walls and rounded corners may offer better paste release. IPC-7525 may have alternate design recommendations.
7. Board assembly site may have different recommendations for stencil design.

## IMPORTANT NOTICE AND DISCLAIMER

TI PROVIDES TECHNICAL AND RELIABILITY DATA (INCLUDING DATA SHEETS), DESIGN RESOURCES (INCLUDING REFERENCE DESIGNS), APPLICATION OR OTHER DESIGN ADVICE, WEB TOOLS, SAFETY INFORMATION, AND OTHER RESOURCES "AS IS" AND WITH ALL FAULTS, AND DISCLAIMS ALL WARRANTIES, EXPRESS AND IMPLIED, INCLUDING WITHOUT LIMITATION ANY IMPLIED WARRANTIES OF MERCHANTABILITY, FITNESS FOR A PARTICULAR PURPOSE OR NON-INFRINGEMENT OF THIRD PARTY INTELLECTUAL PROPERTY RIGHTS.

These resources are intended for skilled developers designing with TI products. You are solely responsible for (1) selecting the appropriate TI products for your application, (2) designing, validating and testing your application, and (3) ensuring your application meets applicable standards, and any other safety, security, regulatory or other requirements.

These resources are subject to change without notice. TI grants you permission to use these resources only for development of an application that uses the TI products described in the resource. Other reproduction and display of these resources is prohibited. No license is granted to any other TI intellectual property right or to any third party intellectual property right. TI disclaims responsibility for, and you will fully indemnify TI and its representatives against, any claims, damages, costs, losses, and liabilities arising out of your use of these resources.

TI's products are provided subject to [TI's Terms of Sale](#) or other applicable terms available either on [ti.com](https://www.ti.com) or provided in conjunction with such TI products. TI's provision of these resources does not expand or otherwise alter TI's applicable warranties or warranty disclaimers for TI products.

TI objects to and rejects any additional or different terms you may have proposed.

Mailing Address: Texas Instruments, Post Office Box 655303, Dallas, Texas 75265  
Copyright © 2023, Texas Instruments Incorporated