

0.6 mm Pitch, Docking Station Connectors

EX80 Series

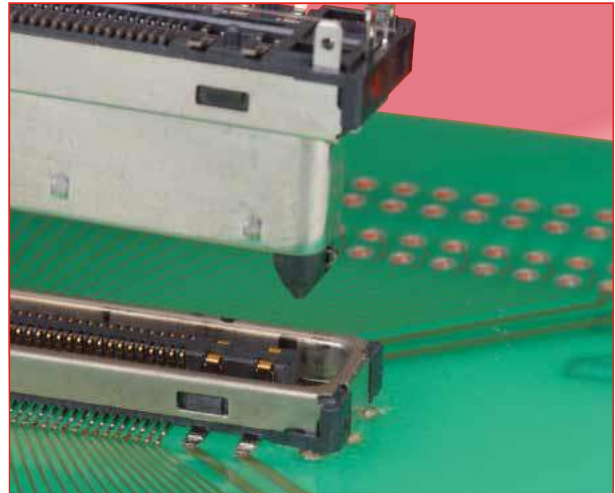

■ Features

1. Secure electrical and mechanical connection

The signal contacts wipe of 1.5 mm and built-in self-alignment assures reliable connection between plug and receptacle.

2. Sequential mating

Plug design assures correct contact engagement sequence: ground-signal-power.

3. Reliable ground connection

Guide tabs on the metal shell assure correct grounding sequence and high ground connection reliability with the board.

4. High-speed data transfer

Signals of 2.5 G bps can be transferred (PCI express).

5. Prevention of flux wicking

Terminations of the contacts are designed to prevent a possibility of flux wicking into the contact areas.

6. Self alignment

The connectors will self-align in X/Y axis within 1.2mm (0.7mm for receptacles with self-opening shutters)

7. Dedicated power supply contacts

High electrical conductivity dedicated power contacts are rated 3 A.

8. High durability

Bellows contact configuration assures reliable electrical and mechanical connection for 5,000 cycles (mating/un-mating).

■ Applications

Docking stations for notebook computers and other applications requiring high reliability, high data transfer sequential mating connections.

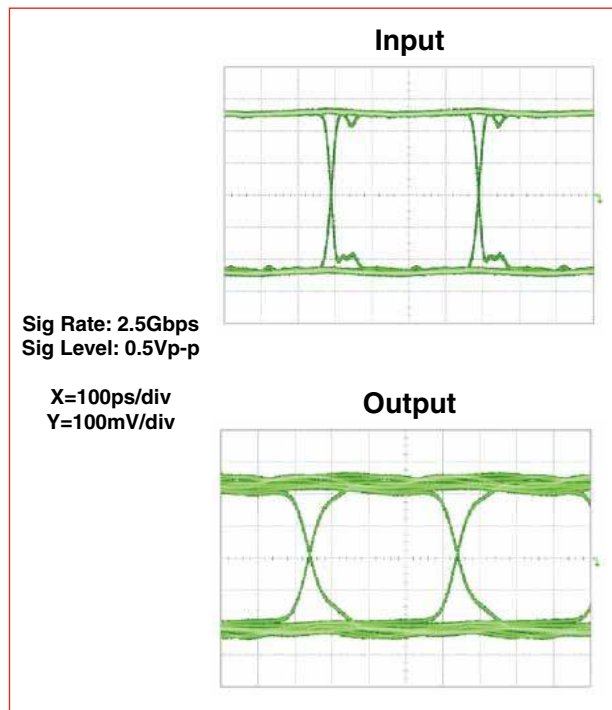

■ Product specifications

Ratings	Storage temperature range	-55°C to +85°C	
	Voltage rating	125V AC	
	Current rating	Signal contact	0.5A
Power contact		3A	

Characteristic	Specification	Conditions
1. Contact resistance	Signal contact: 70 mΩ max. Power contact: 40 mΩ max.	100m A
2. Insulation resistance	300 MΩ min.	250 V DC
3. Withstanding voltage	No flashover or insulation breakdown.	350 V AC/one minute

■ Materials

● Receptacles

Component	Material	Finish
Contacts	Copper alloy	Selective gold plated
Insulator	LCP	—————
Shell	Stainless steel	Nickel / tinned copper plated

● Plugs

Component	Material	Finish
Contacts	Copper alloy	Selective gold plated
Insulator	LCP	—————
Shell	Stainless steel	Nickel / tinned copper plated

■ Ordering information

● Receptacles

EX 80 – 54(50) S – SH (05)

① ② ③ ④ ⑤ ⑥

● Plugs

EX 80 – 54(50) P (01)

① ② ③ ④ ⑥

① Series number	: EX
② Model serial indicator 80	: Vertical SMT type : 54, 100
③ Number of contacts	: 54(50)... 50 contacts mounted in a 54-contact size
④ Connector types	S: Receptacle connectors (Shell ground tab length 0.9 mm) P: Plug connectors (Shell ground tab length 0.9 mm) P1: Plug connectors (Shell ground tab length 2.2 mm)
⑤ Receptacle, with shutter	SH: Built-in shutters
⑥ Separate specifications	: See the Specifications Sheet of each products.

Note: All connectors in this series are designed to be placed on the PCB 1mm min. thick.

■ Plugs

● 100 pos.

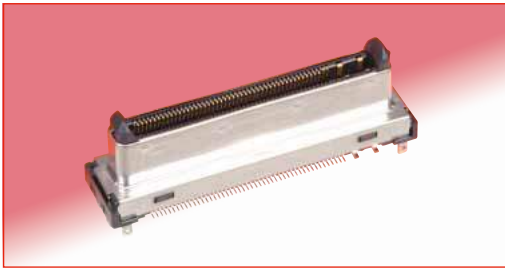

◆ Recommended PCB mounting pattern (PCB thickness : 1 mm min.)

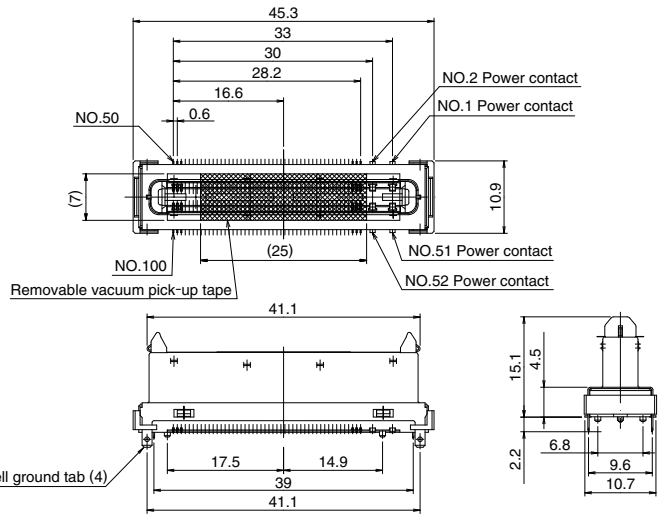
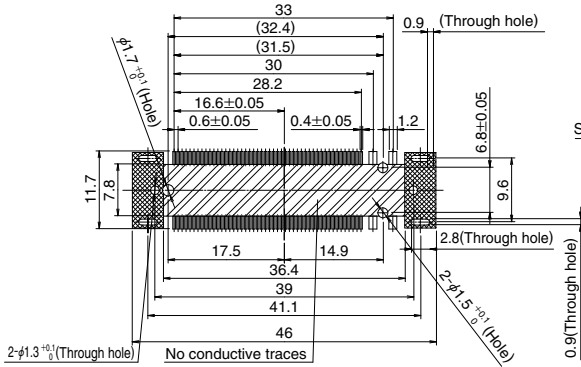

Part No.	HRS No.	Contact plating (contact area/termination)	Shell plating (Body / termination)	Packaging	RoHS
EX80-100P1(50)	232-0598-9 50	Gold / Tinned copper	Nickel / Tinned copper	1 pcs/tray	○

● 54 pos.



◆ Recommended PCB mounting pattern (PCB thickness : 1 mm min.)

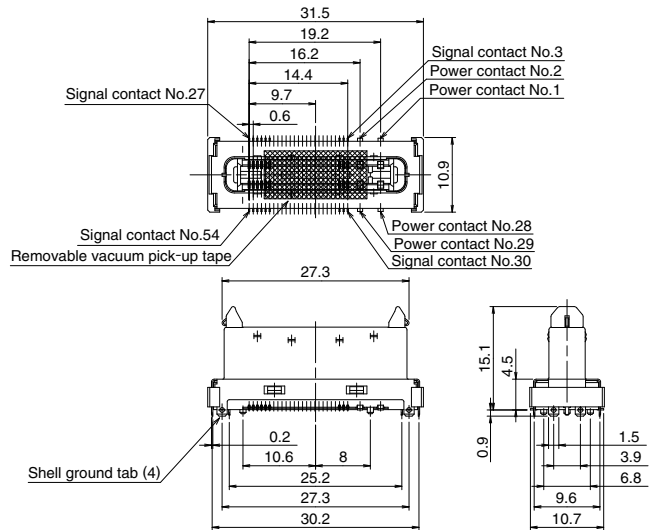
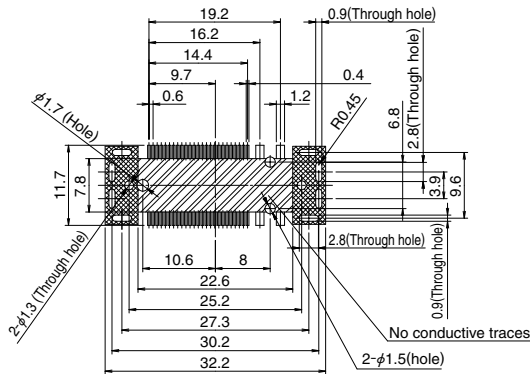

Part No.	HRS No.	Contact plating (contact area/termination)	Shell plating (Body / termination)	Packaging	RoHS
EX80-54P(01)	232-0610-2 01	Gold / Tinned copper	Nickel / Tinned copper	1 pcs/tray	○

Note: The design of the EX80-54P(01) does not have a detection signal contact.

Receptacles (Without shutter)

100 pos.

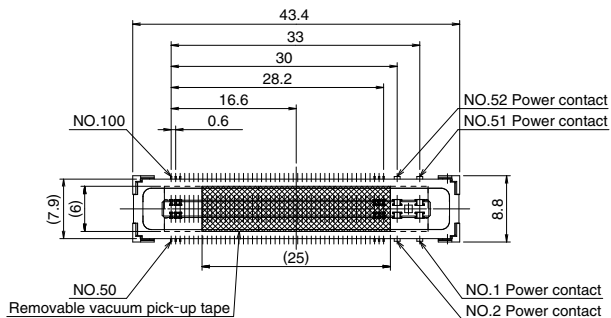
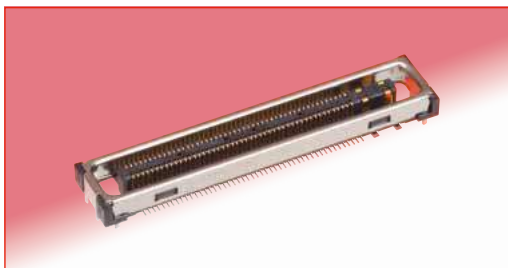

Recommended PCB mounting pattern (PCB thickness : 1 mm min.)

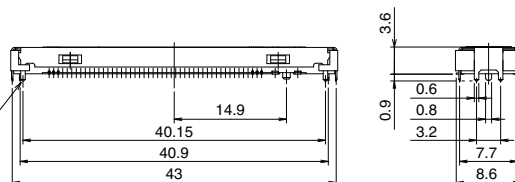
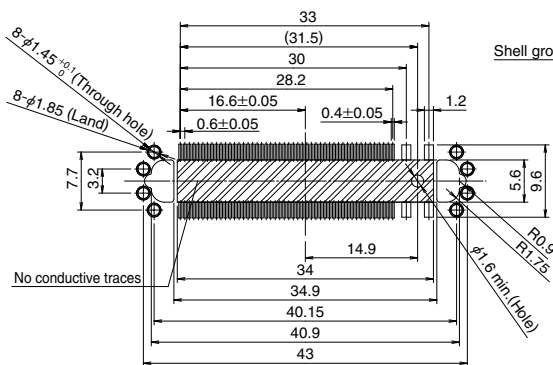

Part No.	HRS No.	Contact plating (contact area/termination)	Shell plating (Body / termination)	Packaging	RoHS
EX80-100S(50)	232-0592-2 50	Gold / Tinned copper	Nickel / Tinned copper	1 pcs/tray	○
EX80-100S(51)	232-0592-2 51			1,000 pcs/reel	

54 pos.

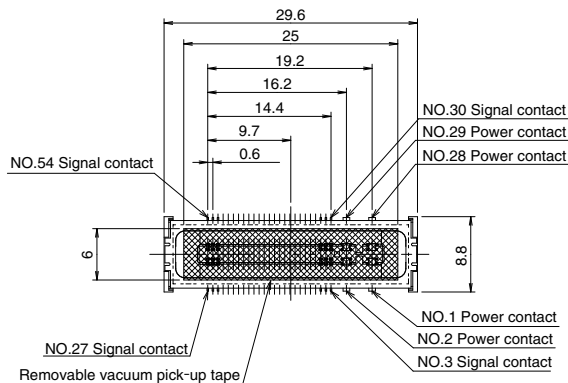

Recommended PCB mounting pattern (PCB thickness : 1 mm min.)

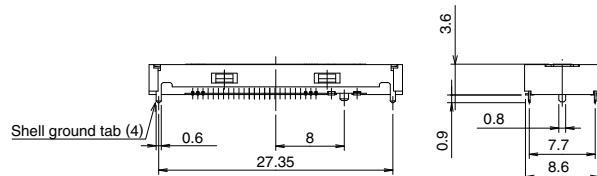
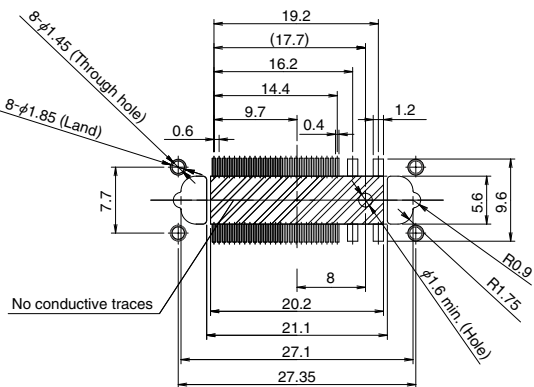

Part No.	HRS No.	Contact plating (contact area/termination)	Shell plating (Body / termination)	Packaging	RoHS
EX80-54S	232-0609-3	Gold / Tinned copper	Nickel / Tinned copper	1,000 pcs/reel	○

■ Plug (For the Receptacle with shutter)

●54 pos.

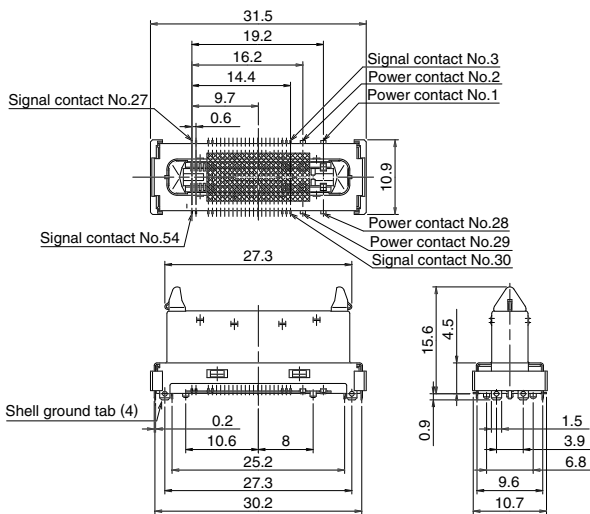

◆ Recommended PCB mounting pattern (PCB thickness : 1 mm min.)

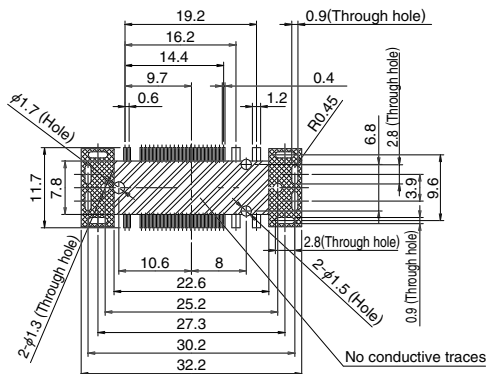

Part No.	HRS No.	Contact plating (contact area/termination)	Shell plating (Body / termination)	Packaging	RoHS
EX80-54(50)P	232-0607-8	Gold / Tinned copper	Nickel / Tinned copper	1 pcs/tray	○

Note: The design of the EX80-54(50)P does not have a detection signal contact.

■ Receptacle (With shutter)

●54 pos.



◆ Shown without shutter

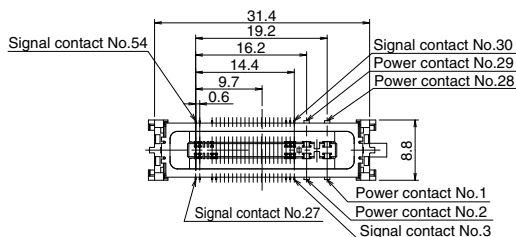

◆ Recommended PCB mounting pattern (PCB thickness : 1 mm min.)

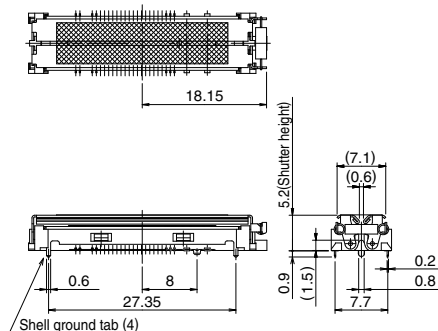
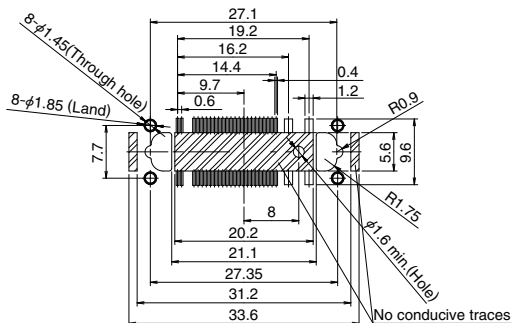

Part No.	HRS No.	Contact plating (contact area/termination)	Shell plating (Body / termination)	Shutter color	Packaging	RoHS
EX80-54(50)S-SH(05)	232-0606-5 05	Gold / Tinned copper	Nickel / Tinned copper	Silver	500 pcs/reel	○
EX80-54(50)S-SH(06)	232-0606-5 06			Black		

◆ Connector mounting condition

● Type without shutters

Housing mounting condition
(Shown for reference only)

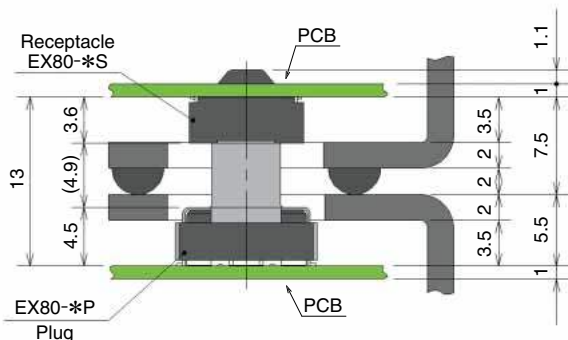

● Type with shutters

Housing mounting condition
(Shown for reference only)

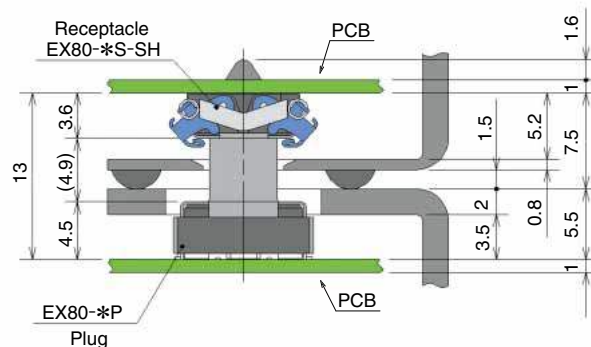

Note: The stacking length between boards of this connector is 13 mm.

◆ Precautions

- Make the stacking height design value of the set 13.0 to 13.7 mm. Establish the setting so that the stacking height is 14.5 mm or less including the accumulative tolerance of the set.
- Use a floating structure (of 1.2 mm or less) to mount this product. (Within 0.7 mm for the type with shutters)
- Be sure to also establish a guide structure on the set side.
- For set designs in which the connector rotates and mates, make the radius of the rotation axis 100 mm or greater.

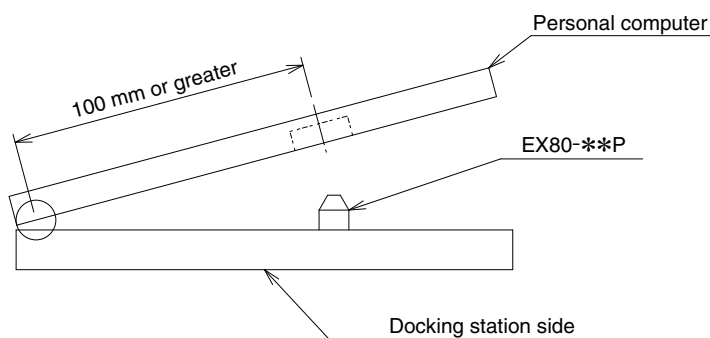

HIROSE ELECTRIC CO.,LTD.

2-6-3,Nakagawa Chuoh,Tsuzuki-Ku,Yokohama-Shi 224-8540,JAPAN
 TEL: +81-45-620-3526 Fax: +81-45-591-3726
<http://www.hirose.com>
<http://www.hirose-connectors.com>