

FEATURES

- Meets MIPI Alliance SoundWire Specification Version 1.1**
- Clocking, audio data and control handled over 2-wire interface**
- SoundWire interface support at 1.2 V or 1.8 V**
- Filterless digital input, mono Class D amplifier with Σ - Δ modulation**
- 4.5 V to 17 V operation, such as a 2-cell or 3-cell battery**
- Input/output supply operation from 1.1 V to 1.90 V**
- 30.2 W output power, 17 V supply and 4 Ω load at 1% THD + N**
- 37.5 μ V rms noise, 107 dB A weighted SNR**
- Supports sample rates from 8 kHz to 192 kHz**
- Flexible digital and analog gain adjustment**
- AGC with battery voltage-based limiter**
- 74 dB SNR on output current sensing and 85 dB SNR on voltage sensing**
- 6.63 mA quiescent current at 12 V PV_{DD} supply**
- Temperature sensor with 1°C readout**
- Short-circuit, thermal protection, and thermal warning**
- 23-ball, 2.26 mm \times 2.38 mm, 0.4 mm pitch WLCSP**

APPLICATIONS

- Mobile computing**
- Portable electronics**

GENERAL DESCRIPTION

The SSM3525-MIPI consists of all the blocks available in the [SSM3525](#) plus a SoundWire® block. This data sheet provides detailed information on the SoundWire block.

The SSM3525-MIPI is a fully integrated, high efficiency, mono Class D audio amplifier with digital input and digitized output of output voltage, output current, and PV_{DD} supply with SoundWire interface. The SoundWire interface meets the MIPI® SoundWire Specification Version 1.1. For more detailed technical information on the SoundWire protocol, refer the MIPI Alliance SoundWire Specification Version 1.1.

The SoundWire protocol allows transport of control information, setup commands and audio data, such as pulse-code modulation (PCM) or pulse-density modulation (PDM) data, or other payload data over a 2-pin interface. The 2-pin interface uses the SW_CLK and SW_DATA pins to connect to the SoundWire bus. The SoundWire bus usually consists of one master interface and one or more slave interfaces, up to a maximum of eleven slave interfaces.

The SoundWire protocol allows increased system flexibility and system level power saving, as well as support for interrupt alerts to the master interface from slave interfaces.

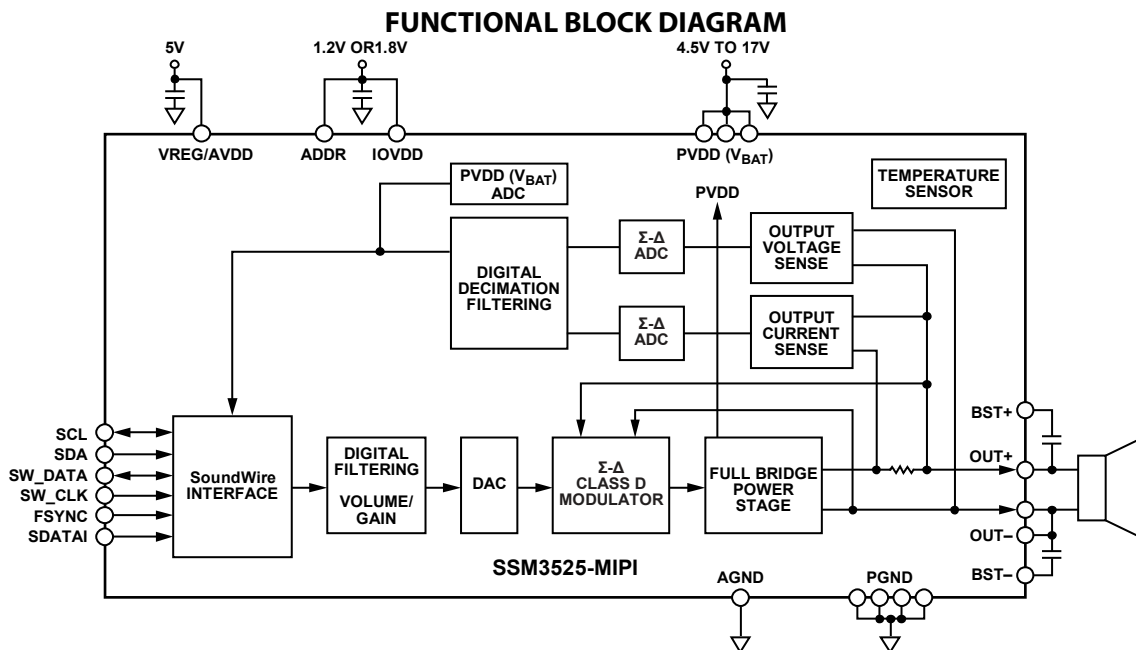

Figure 1. SSM3525-MIPI SoundWire Mode Block Diagram

For more information about the SSM3525-MIPI, contact Analog Devices, Inc., at consumer.Apps@analog.com.

Rev. Sp0

[Document Feedback](#)

Information furnished by Analog Devices is believed to be accurate and reliable. However, no responsibility is assumed by Analog Devices for its use, nor for any infringements of patents or other rights of third parties that may result from its use. Specifications subject to change without notice. No license is granted by implication or otherwise under any patent or patent rights of Analog Devices. Trademarks and registered trademarks are the property of their respective owners.

One Technology Way, P.O. Box 9106, Norwood, MA 02062-9106, U.S.A.
Tel: 781.329.4700 ©2020 Analog Devices, Inc. All rights reserved.
[Technical Support](#) www.analog.com

NOTES