

THIS DRAWING IS UNPUBLISHED. RELEASED FOR PUBLICATION 20
 © COPYRIGHT 20 BY - ALL RIGHTS RESERVED.

REVISIONS					
P	LTR	DESCRIPTION	DATE	DWN	APVD
	A	RELEASE	08NOV2016	JY	SH
	A1	REVISED PER ECN-22-135982	24JAN2022	PT	SZ
	A2	REVISED PER ECN-22-163746	11JUL2022	IT	SZ

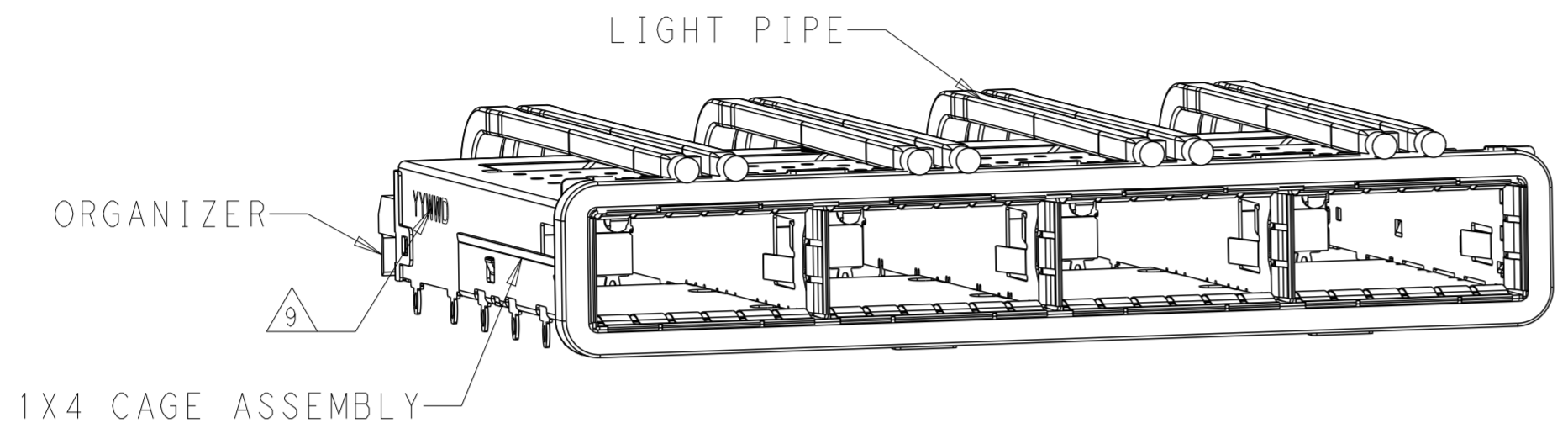

2170784-1 AS SHOWN

- COMPONENTS
 CAGE ASSEMBLY: NICKEL-SILVER ALLOY
 HEAT SINK: ALUMINUM/BLACK ANODIZE
 HEAT SINK CLIP: STAINLESS STEEL
 EMI SPRING: COPPER ALLOY/NICKEL PLATE
 LIGHT PIPE: CLEAR POLYCARBONATE WITH UL 94 V-0
 ORGANIZER: POLYESTER WITH UL 94 V-0
 EMI GASKET: PLATED FILLED SILICONE
- REFERENCE APPLICATION SPECIFICATION 114-32023 FOR RECOMMENDED DRILL HOLE DIAMETER AND PLATING THICKNESS
- DATUM AND BASIC DIMENSION ESTABLISHED BY CUSTOMER
- MATES WITH QSFP28 MSA COMPATIBLE TRANSCEIVER.
- LIGHT PIPES ARE SHIPPED ASSEMBLED ON CAGE
- MINIMUM PC BOARD THICKNESS: SINGLE SIDED: 1.57 MIN
DOUBLE SIDED: 3.00 MIN
- DATUM **-A-** IS TOP SURFACE OF THE HOST BOARD.
- THESE HOLES ARE OPTIONAL WHEN THE REAR PINS ARE REMOVED.
- DATE CODE (YYWWD) MARKED APPROXIMATELY AS SHOWN.

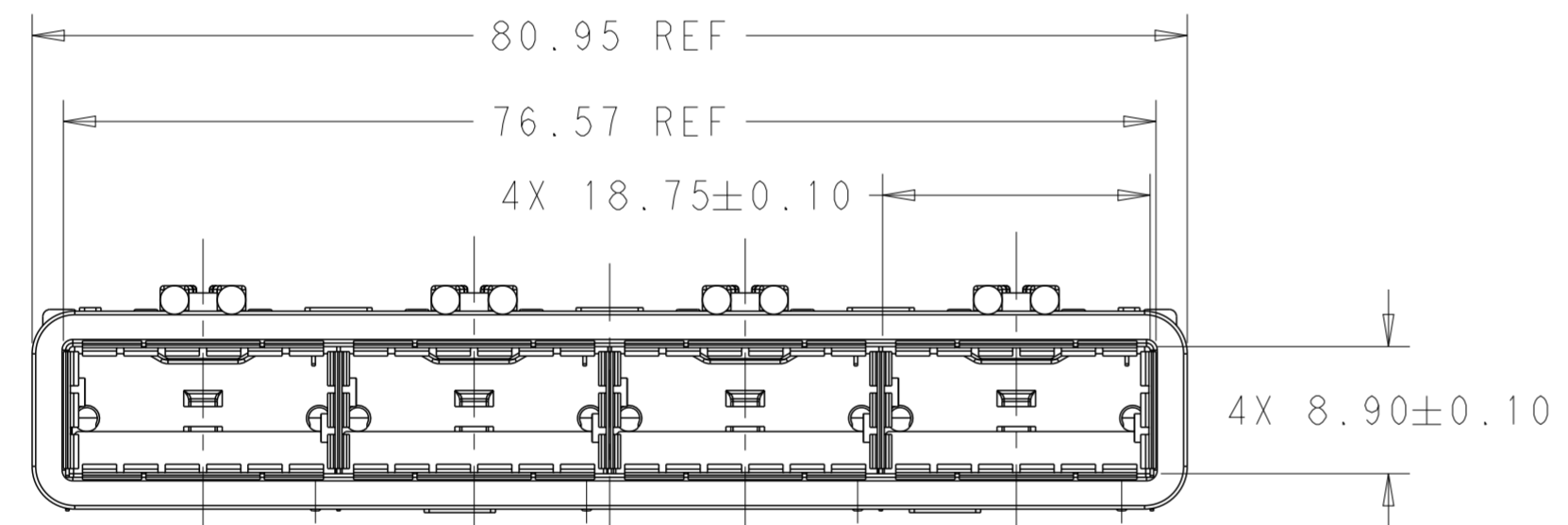

SCALE 2:1

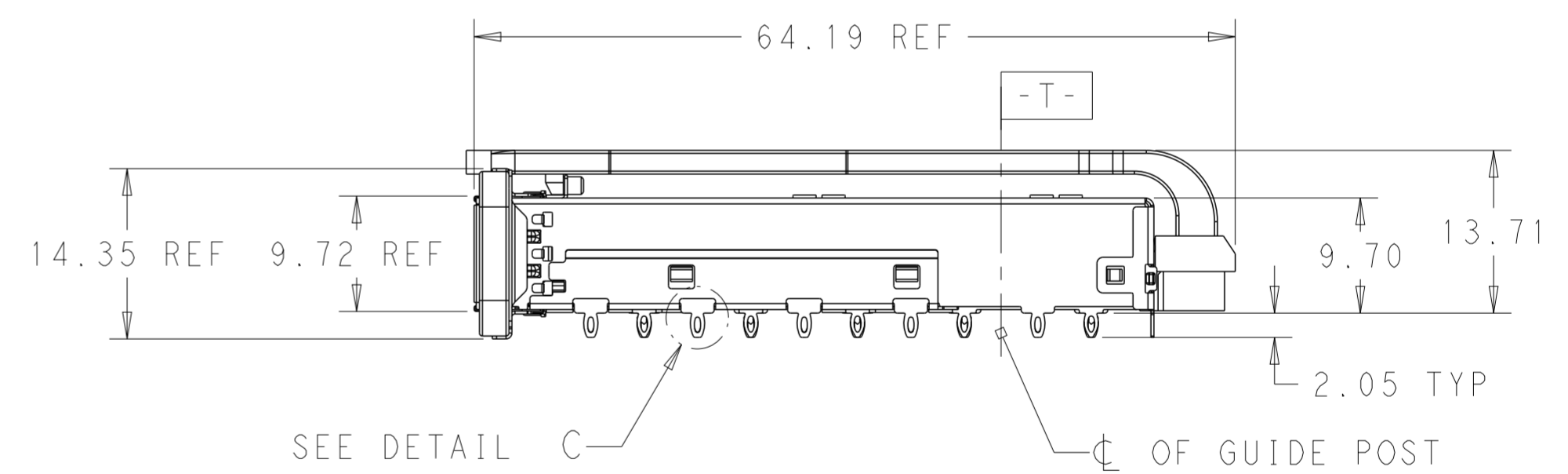

SEE DETAIL C

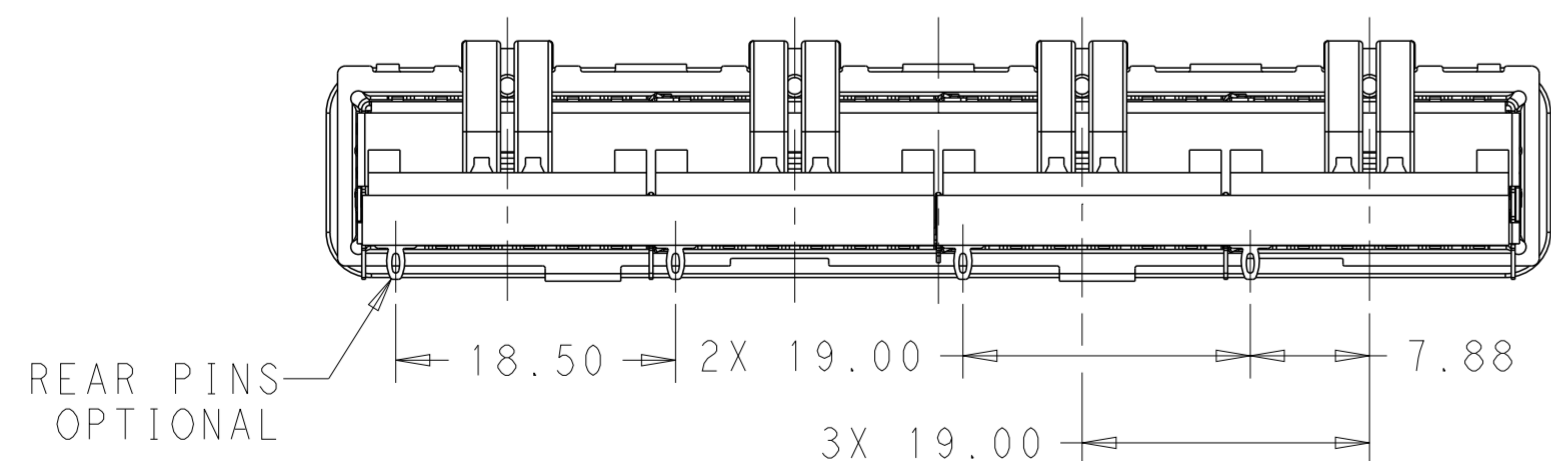

BACK VIEW SCALE 2:1

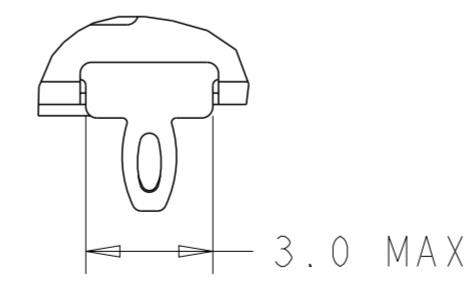

DETAIL C SCALE 6:1

1LP	WITHOUT	2170784-3
2LP	WITHOUT	2170784-2
2LP	WITH	2170784-1
LP POSN OPTIONAL	REAR PINS OPTIONAL	PART NUMBER

DIMENSIONS:		TOLERANCES UNLESS OTHERWISE SPECIFIED:		DWN 26 JAN 2014		CHK 08 NOV 2016		APVD		NAME	
mm	0 PLC	±		JASON YANG	SEAN HAN	STE		TE Connectivity		RECEPTACLE CAGE ASSEMBLY	
	1 PLC	±0.25		PRODUCT SPEC		108-19428		SIZE		CAGE CODE	
	2 PLC	±0.2		APPLICATION SPEC		11-32023		DRAWING NO		RESTRICTED TO	
	3 PLC	±		WEIGHT		-		A200779		C-2170784	
	4 PLC	±		CUSTOMER DRAWING		SCALE 3:1		SHEET 1 OF 6		REV A2	
	ANGLES	±									
	FINISH	±									
	MATERIAL	SEE NOTES									

THIS DRAWING IS UNPUBLISHED. RELEASED FOR PUBLICATION 20
 © COPYRIGHT 20 BY - ALL RIGHTS RESERVED.

REVISIONS				
P	LTR	DESCRIPTION	DATE	APVD
-	-	SEE SHEET 1	-	-

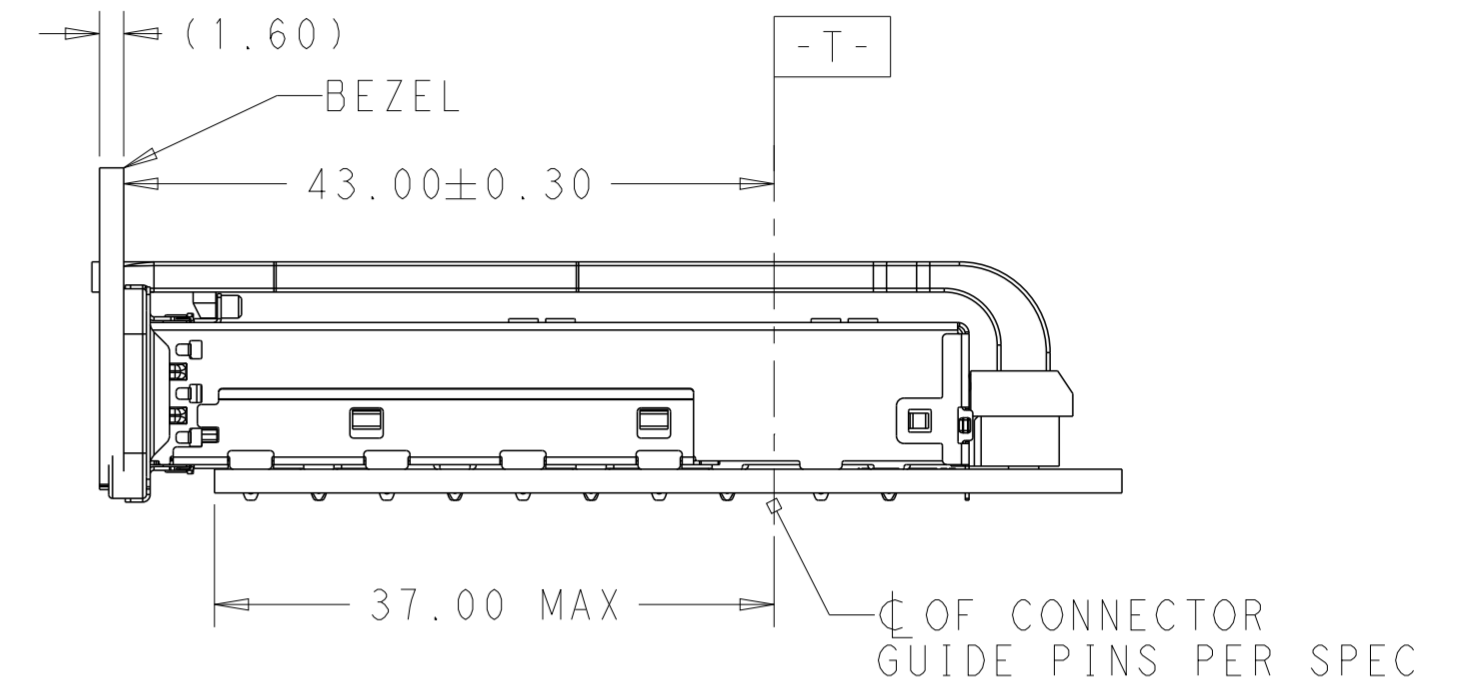
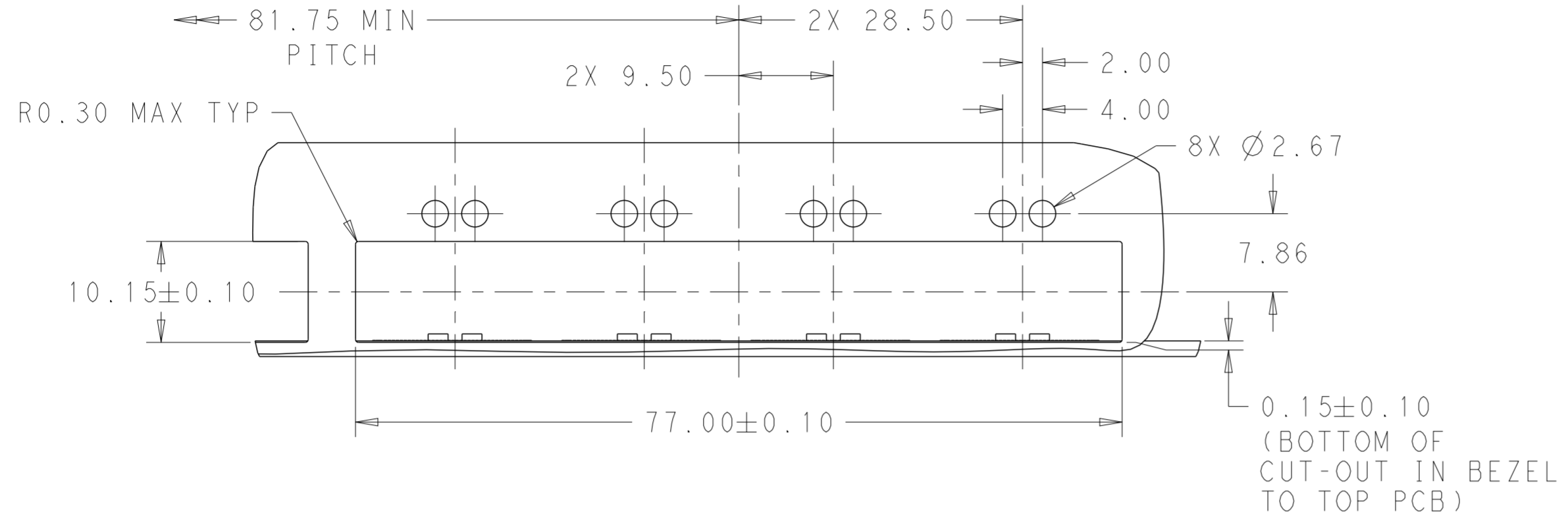

SINGLE SIDE MOUNTING
SCALE 2:1

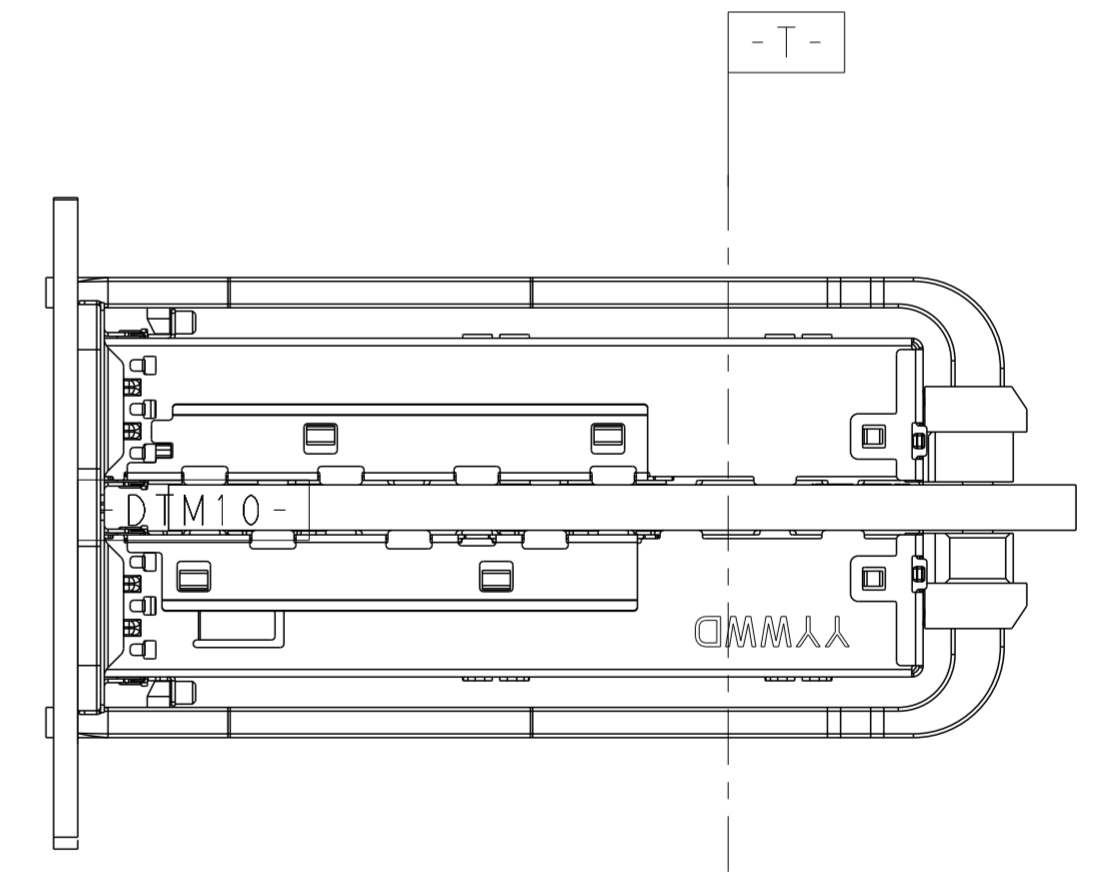
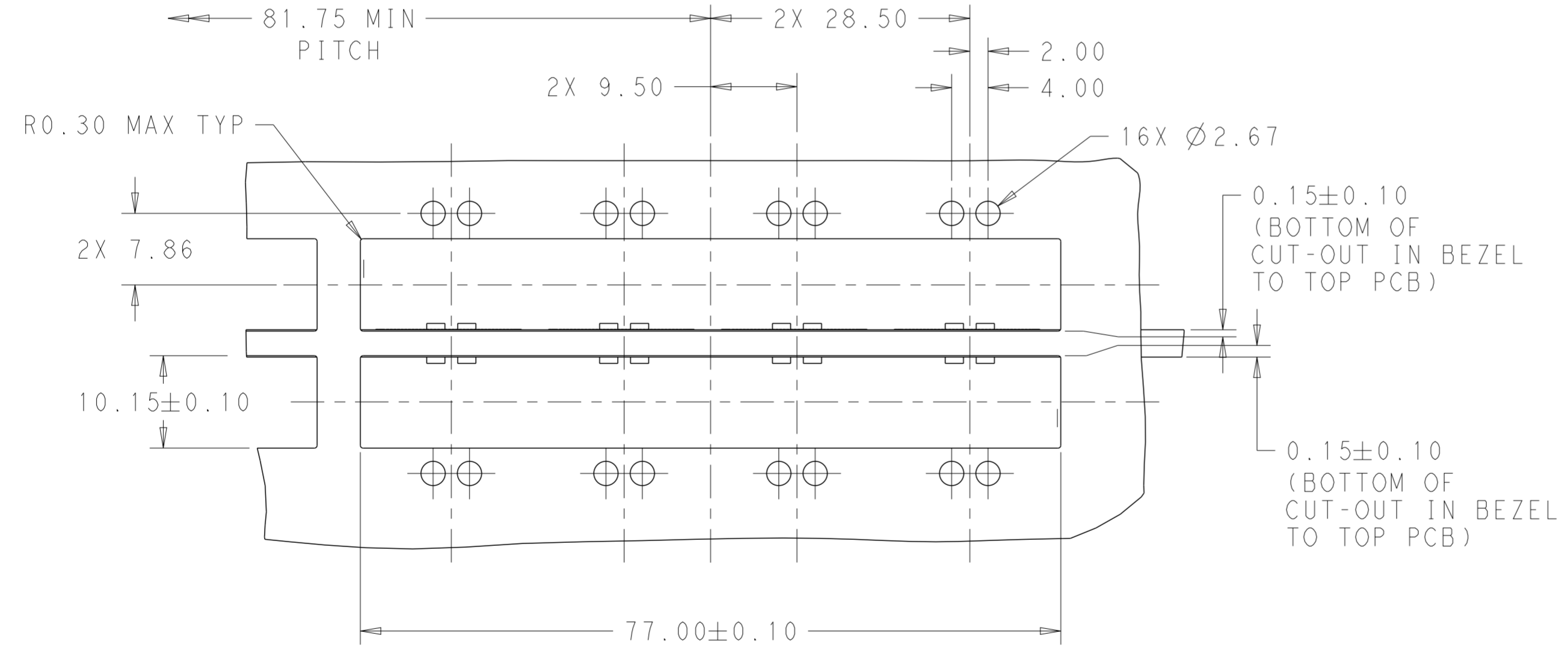

BELLY TO BELLY MOUNTING
SCALE 2:1

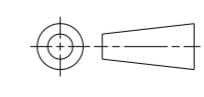
THIS DRAWING IS A CONTROLLED DOCUMENT.		DWN JASON YANG 26 JAN 2014	 TE Connectivity	
		CHK SEAN HAN 08 NOV 2016		
DIMENSIONS: mm	TOLERANCES UNLESS OTHERWISE SPECIFIED:	APVD -	NAME RECEPTACLE CAGE ASSEMBLY 1X4, QSFP28 WITH LIGHT PIPES THRU BEZEL, GASKET	RESTRICTED TO
	0 PLC ± 1 PLC ±0.25 2 PLC ±0.2 3 PLC ± 4 PLC ± ANGLES ± FINISH	PRODUCT SPEC 108-19428	SIZE 11-32023	SIZE A2
MATERIAL SEE NOTES	SEE NOTES	APPLICATION SPEC 11-32023	CAGE CODE A200779	DRAWING NO C-2170784
		WEIGHT -	CUSTOMER DRAWING	SCALE 3:1 SHEET 2 OF 6 REV A2

REVISIONS				
P	LTR	DESCRIPTION	DATE	APVD
-	-	SEE SHEET 1	-	-

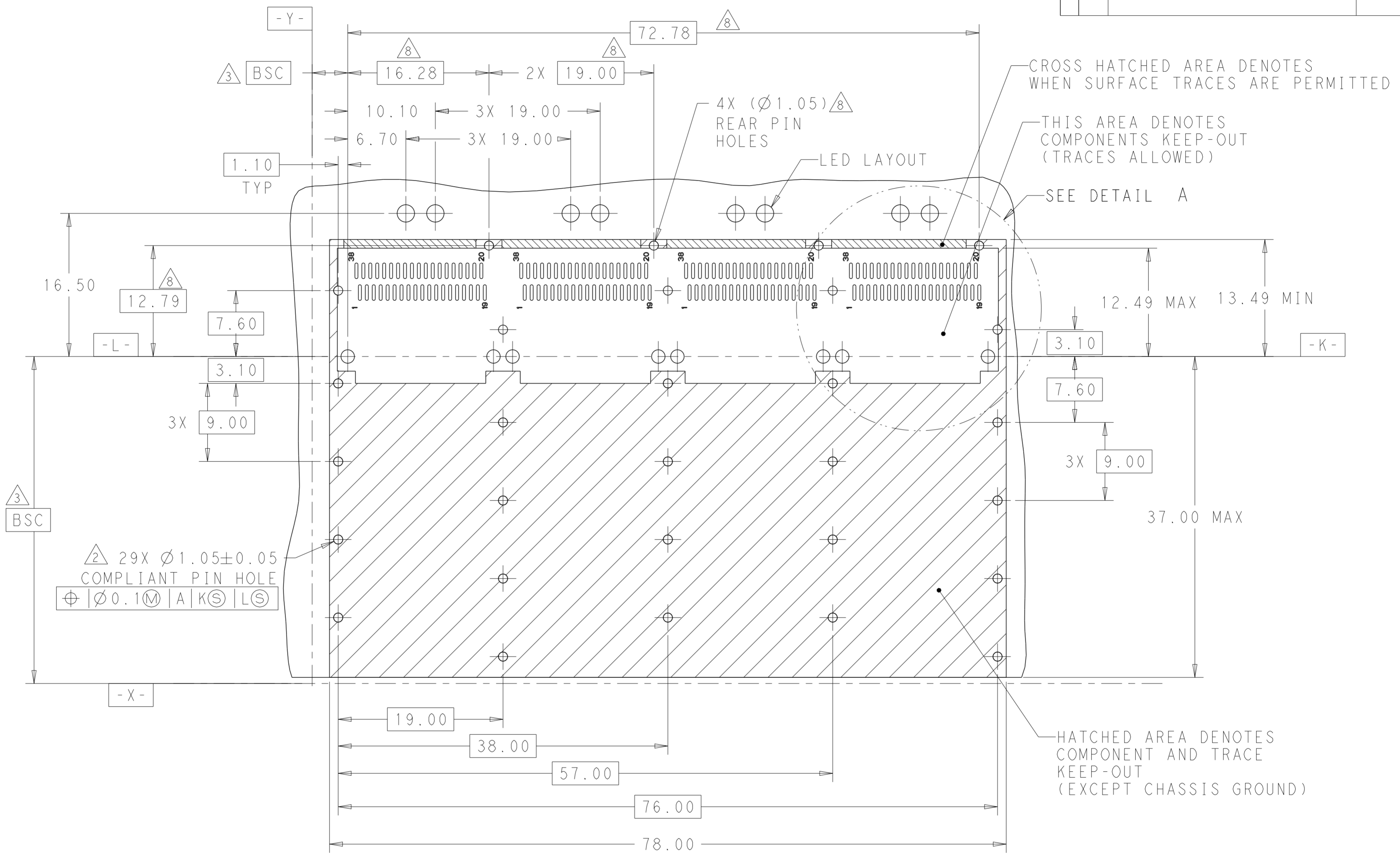

2 29X Ø1.05±0.05
 COMPLIANT PIN HOLE
 Ø0.1(M) | A | K(S) | L(S)

RECOMMENDED PCB LAYOUT
 SINGLE TYPE
 PCB TOLERANCE: ±0.05
 SCALE 3:1

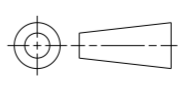
THIS DRAWING IS A CONTROLLED DOCUMENT.		DWN 26 JAN 2014 JASON YANG	 TE Connectivity
		CHK 08 NOV 2016 SEAN HAN	
DIMENSIONS: mm		APVD -	NAME RECEPTACLE CAGE ASSEMBLY 1X4, QSFP28 WITH LIGHT PIPES THRU BEZEL, GASKET
		PRODUCT SPEC 108-19428	SIZE A2
MATERIAL SEE NOTES		APPLICATION SPEC 11-32023	CAGE CODE 00779
TOLERANCES UNLESS OTHERWISE SPECIFIED: 0 PLC ± 1 PLC ±0.25 2 PLC ±0.2 3 PLC ± 4 PLC ± ANGLES ± FINISH SEE NOTES		WEIGHT -	DRAWING NO C-2170784
		CUSTOMER DRAWING	RESTRICTED TO -
		SCALE 3:1	SHEET 3 OF 6 REV A2

REVISIONS				
P	LTR	DESCRIPTION	DATE	APVD
-	-	SEE SHEET 1	-	-

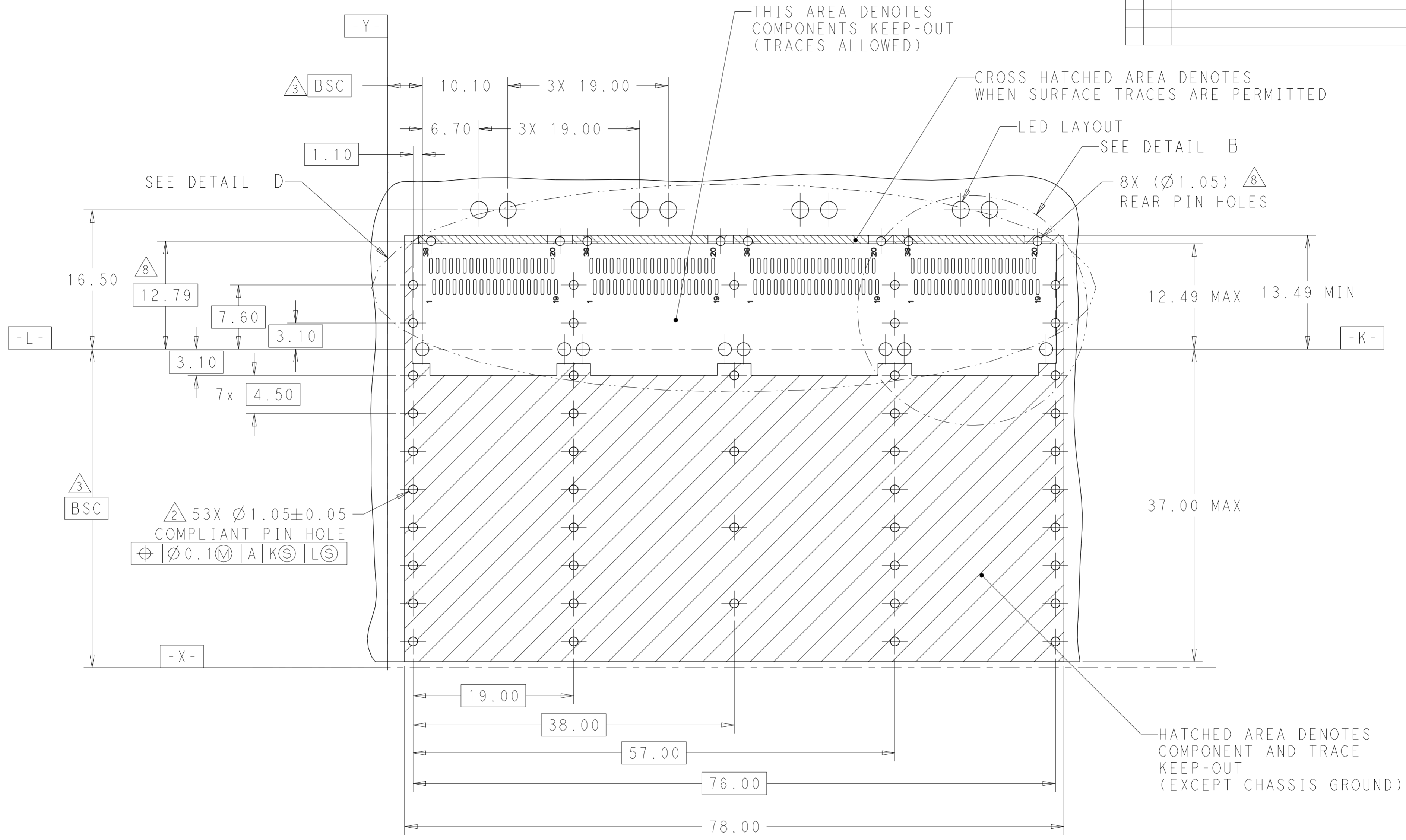

2 53X Ø1.05±0.05
 COMPLIANT PIN HOLE
 ⊕ | Ø0.1M | A | K | S | L | S

RECOMMENDED PCB LAYOUT
 BELLY TO BELLY TYPE
 PCB TOLERANCE: ±0.05
 SCALE 3:1

THIS DRAWING IS A CONTROLLED DOCUMENT.		DWN JASON YANG 26 JAN 2014	TE Connectivity	
		CHK SEAN HAN 08 NOV 2016		
DIMENSIONS: mm	TOLERANCES UNLESS OTHERWISE SPECIFIED:	APVD -	NAME RECEPTACLE CAGE ASSEMBLY 1X4, QSFP28 WITH LIGHT PIPES THRU BEZEL, GASKET	
	0 PLC ± 1 PLC ±0.25 2 PLC ±0.2 3 PLC ± 4 PLC ±	PRODUCT SPEC 108-19428	SIZE 11-32023	RESTRICTED TO -
MATERIAL SEE NOTES	FINISH SEE NOTES	APPLICATION SPEC 11-32023	WEIGHT -	SIZE A2
		CUSTOMER DRAWING	SCALE 3:1	SHEET 4 OF 6
				REV A2

THIS DRAWING IS UNPUBLISHED. RELEASED FOR PUBLICATION 20
 © COPYRIGHT 20 BY - ALL RIGHTS RESERVED.

REVISIONS				
P	LTR	DESCRIPTION	DATE	APVD
-	-	SEE SHEET 1	-	-

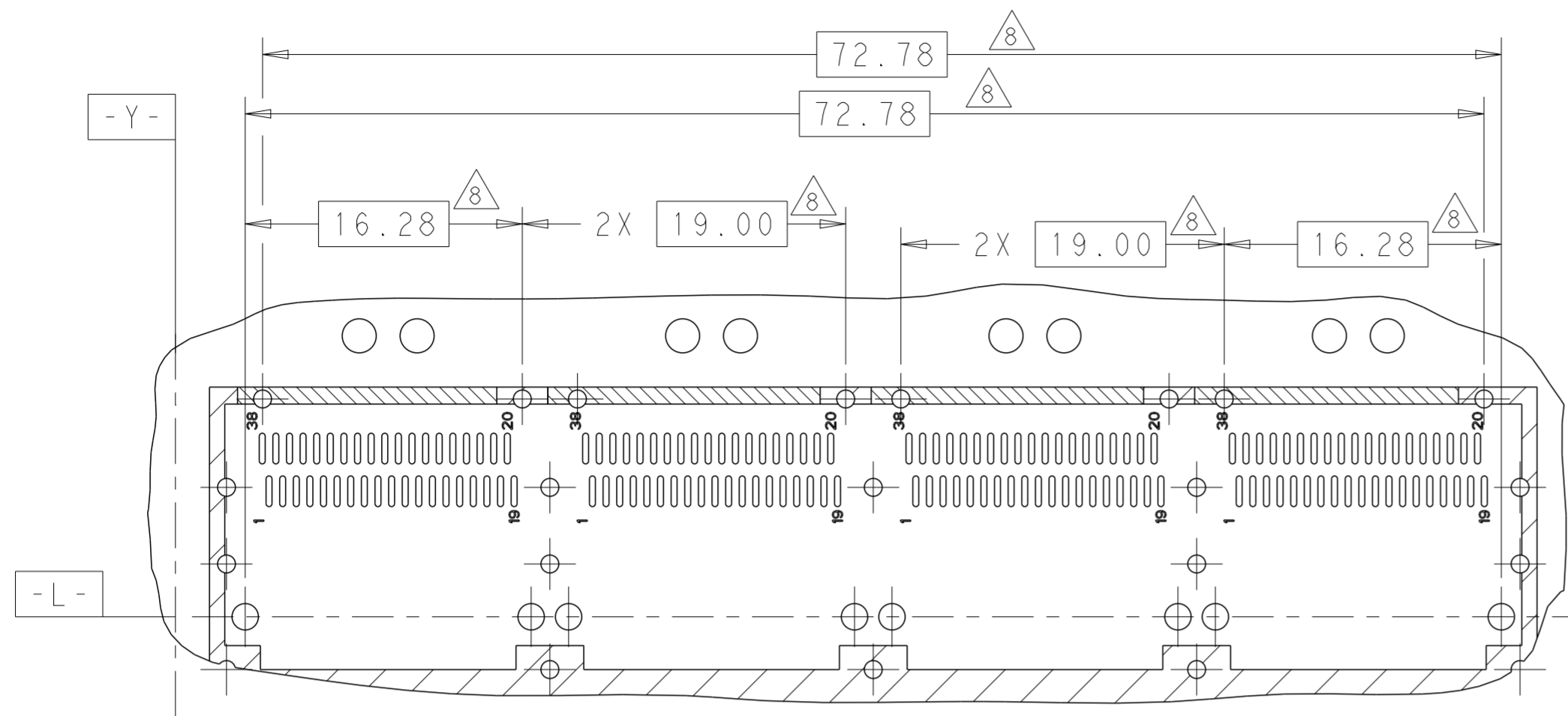

DETAIL D
SCALE 3:1

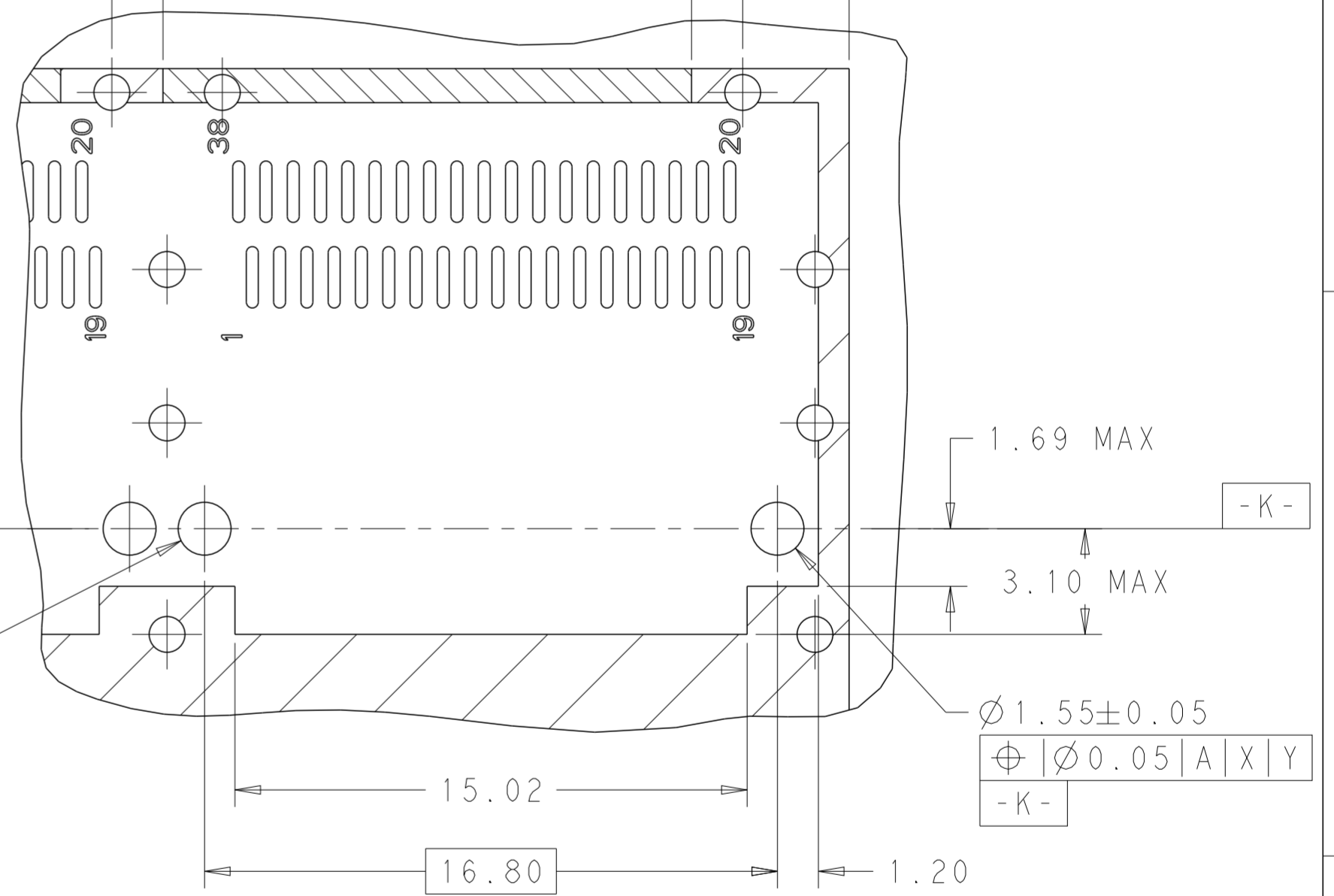

DETAIL B
SCALE 6:1

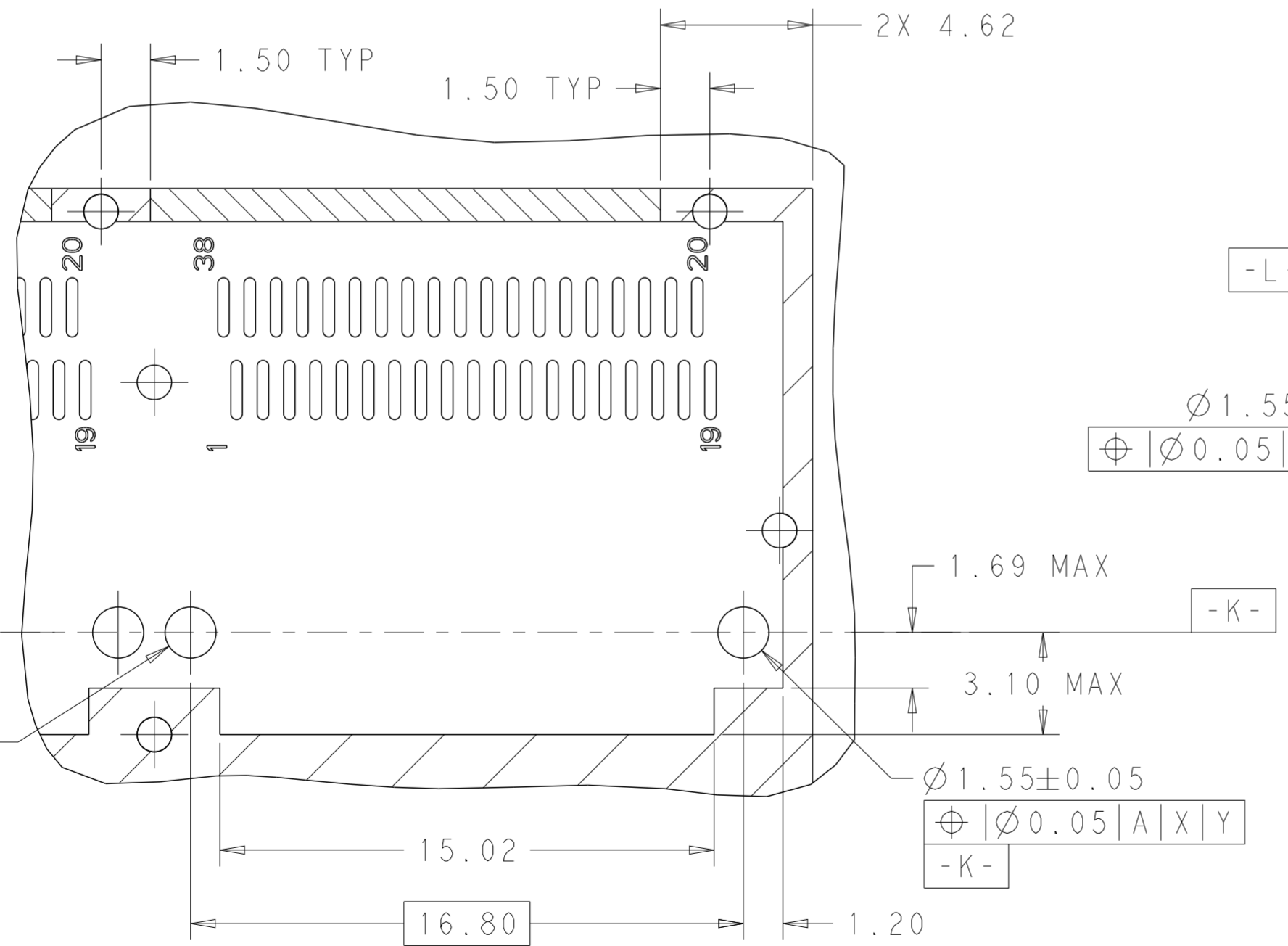

DETAIL A
SCALE 6:1

THIS DRAWING IS A CONTROLLED DOCUMENT.		DWN JASON YANG 26 JAN 2014	STE TE Connectivity	
		CHK SEAN HAN 08 NOV 2016		
DIMENSIONS: mm	TOLERANCES UNLESS OTHERWISE SPECIFIED: 0 PLC ± 1 PLC ±0.25 2 PLC ±0.2 3 PLC ± 4 PLC ± ANGLES ± FINISH	APVD -	NAME RECEPTACLE CAGE ASSEMBLY 1X4, QSFP28 WITH LIGHT PIPES THRU BEZEL, GASKET	RESTRICTED TO -
MATERIAL SEE NOTES	SEE NOTES	PRODUCT SPEC 108-19428	SIZE 11-32023	SCALE 3:1
		WEIGHT -	CAGE CODE A200779	SHEET 5 OF 6
		CUSTOMER DRAWING	DRAWING NO C-2170784	REV A2

THIS DRAWING IS UNPUBLISHED. RELEASED FOR PUBLICATION 20
 © COPYRIGHT 20 BY - ALL RIGHTS RESERVED.

REVISIONS				
P	LTR	DESCRIPTION	DATE	APVD
-	-	SEE SHEET 1	-	-

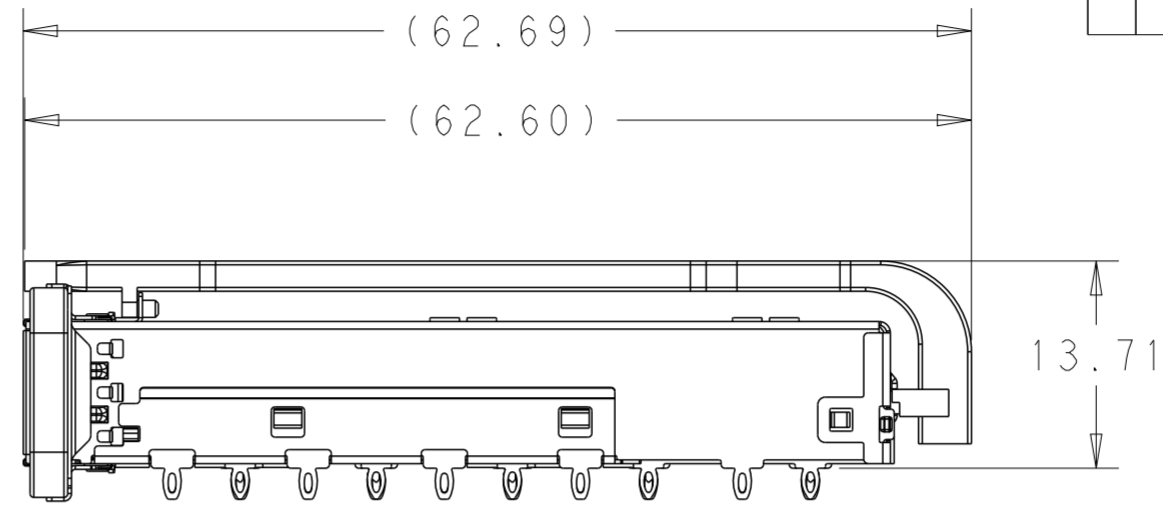
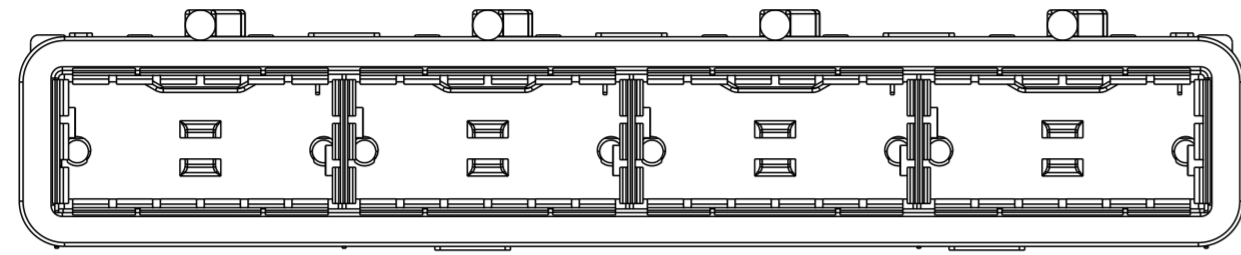

2170784-3 AS SHOWN
 SCALE 2:1

THIS DRAWING IS A CONTROLLED DOCUMENT.		DWN JASON YANG 26 JAN 2014	 TE Connectivity	
		CHK SEAN HAN 08 NOV 2016		
DIMENSIONS:	TOLERANCES UNLESS OTHERWISE SPECIFIED:	APVD -	NAME RECEPTACLE CAGE ASSEMBLY 1X4, QSFP28 WITH LIGHT PIPES THRU BEZEL, GASKET	
mm	0 PLC ± 1 PLC ±0.25 2 PLC ±0.2 3 PLC ± 4 PLC ±	PRODUCT SPEC 108-19428	SIZE 11-32023	CAGE CODE A200779
MATERIAL SEE NOTES	FINISH SEE NOTES	APPLICATION SPEC 11-32023	DRAWING NO C-2170784	RESTRICTED TO -
		WEIGHT -	SCALE 3:1 SHEET 6 OF 6 REV A2	
		CUSTOMER DRAWING		