

REV.	DATE	ECR NO.	DESCRIPTION
NC	05/31/08	100024	INITIAL RELEASE

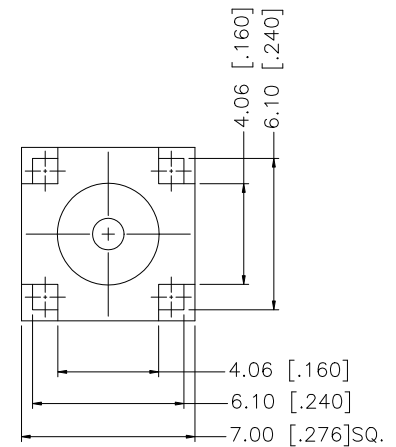
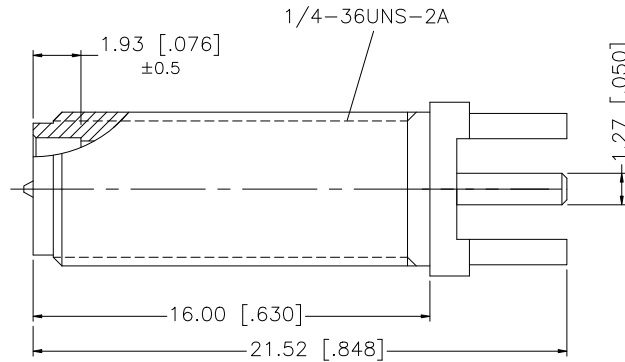
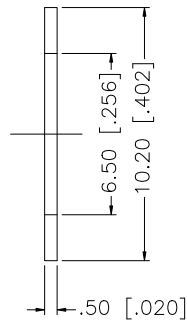
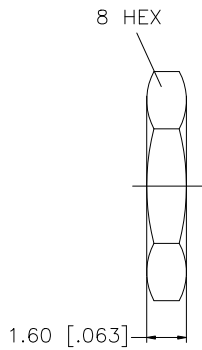
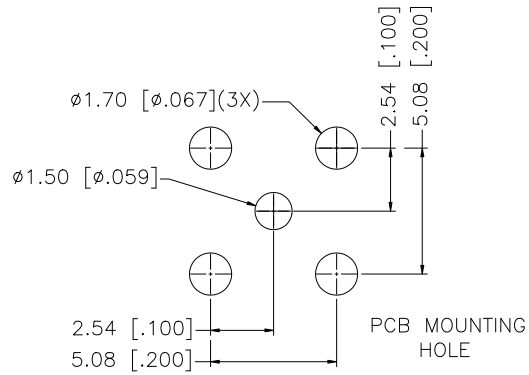

DESCRIPTION	MATERIAL	FINISH	QTY
8			
7			
6			
5	HEX NUT	BRASS	GOLD 1
4	WASHER	BRASS	GOLD 1
3	CONTACT PIN	BRASS	GOLD 1
2	INSULATOR	PTFE	NATURAL 1
1	BODY	BRASS	GOLD 1

UNLESS OTHERWISE SPECIFIED DIMENSIONS ARE IN MILLIMETERS. DIMENSIONS IN [] ARE IN INCHES AND FOR CUSTOMER REFERENCE ONLY.

UNLESS OTHERWISE SPECIFIED TOLERANCES FOR MILLIMETERS ARE:
0.5 - 8mm \pm 0.20mm
8 - 30mm \pm 0.40mm
30 - 120mm \pm 0.50mm

UNLESS OTHERWISE SPECIFIED TOLERANCES FOR INCHES ARE:
.020 - .315 = \pm 0.007"
.315 - 1.180 = \pm 0.015"
1.180 - 4.724 = \pm 0.020"

DO NOT SCALE DRAWING

APPROVALS	DATE
DRAWN G.R.S.	05/31/08
CHECKED	
ISSUED	
SHEET 1 OF 1	
CAD FILE C:/132/132291RP.DWG	

<h1>Amphenol Connex</h1>			
PART DESCRIPTION SMA BULKHEAD P.C. MOUNT JACK			
PART NO. 132291RP			
DWG. NO.	132291RP.DWG	REV.	NC
SIZE	A	SCALE	NA