

Silicon Standard Recovery Diode

$V_{RRM} = 200\text{ V} - 800\text{ V}$

$I_F = 150\text{ A}$

Features

- High Surge Capability
- Types from 200 V to 800 V V_{RRM}
- Not ESD Sensitive

Note:

1. Standard polarity: Stud is cathode.
2. Reverse polarity (R): Stud is anode.
3. Stud is base.

DO-8 Package

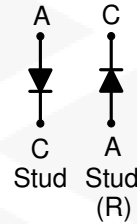

Maximum ratings, at $T_j = 25\text{ }^\circ\text{C}$, unless otherwise specified ("R" devices have leads reversed)

Parameter	Symbol	Conditions	1N4588(R)	1N4590(R)	1N4592(R)	1N4593(R)	Unit
Repetitive peak reverse voltage	V_{RRM}		200	400	600	800	V
DC blocking voltage	V_{DC}		200	400	600	800	V
Continuous forward current	I_F	$T_C \leq 110\text{ }^\circ\text{C}$	150	150	150	150	A
Surge non-repetitive forward current, Half Sine Wave	$I_{F,SM}$	$T_C = 25\text{ }^\circ\text{C}$, $t_p = 8.3\text{ ms}$	3000	3000	3000	3000	A
I_2t for fusing	I_2t	60 Hz Half wave	37200	37200	37200	37200	A^2sec
Operating temperature	T_j		-55 to 150	-55 to 150	-55 to 150	-55 to 150	$^\circ\text{C}$
Storage temperature	T_{stg}		-55 to 150	-55 to 150	-55 to 150	-55 to 150	$^\circ\text{C}$

Electrical characteristics, at $T_j = 25\text{ }^\circ\text{C}$, unless otherwise specified

Parameter	Symbol	Conditions	1N4588(R)	1N4590(R)	1N4592(R)	1N4593(R)	Unit
Diode forward voltage	V_F	$I_F = 150\text{ A}$, $T_j = 110\text{ }^\circ\text{C}$	1.5	1.5	1.5	1.5	V
Reverse current	I_R	$V_R = V_{RRM}$, $T_j = 110\text{ }^\circ\text{C}$	9.5	9	6.5	5.5	mA

Thermal characteristics

Parameter	Symbol	Conditions	1N4588(R)	1N4590(R)	1N4592(R)	1N4593(R)	Unit
Thermal resistance, junction - case	R_{thJC}		0.35	0.35	0.35	0.35	$^\circ\text{C/W}$

Electrical Characteristics

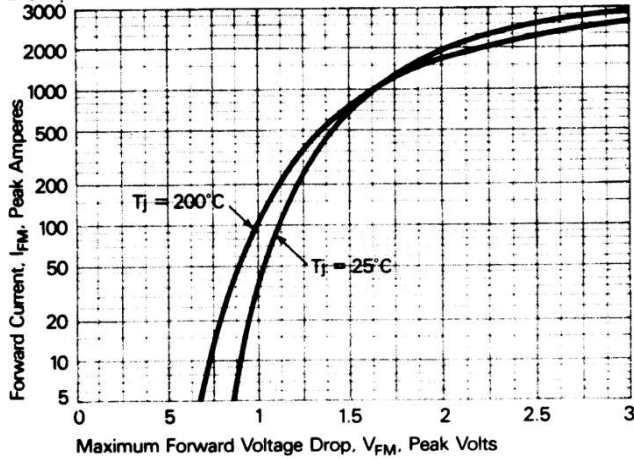

Figure 1. Forward current vs. Forward voltage.

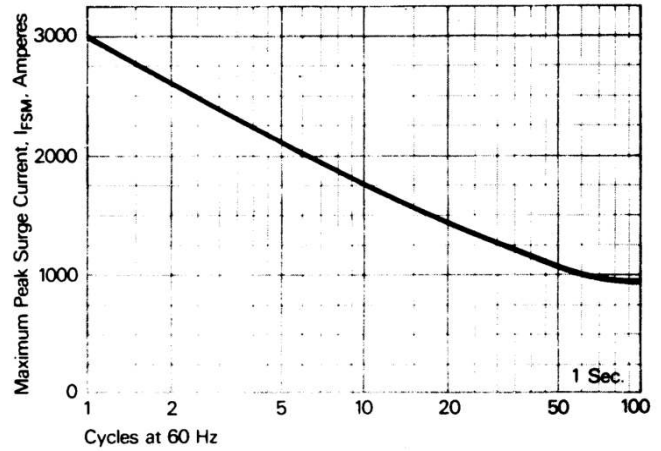

Figure 2. Maximum allowable surge current at rated load conditions.

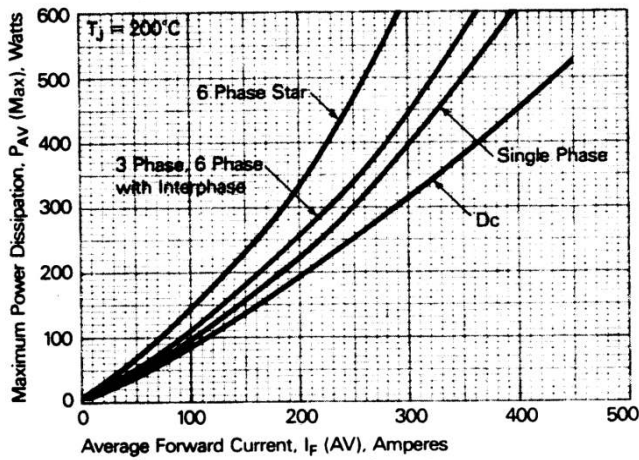

Figure 3. Power dissipation vs. Average forward current.

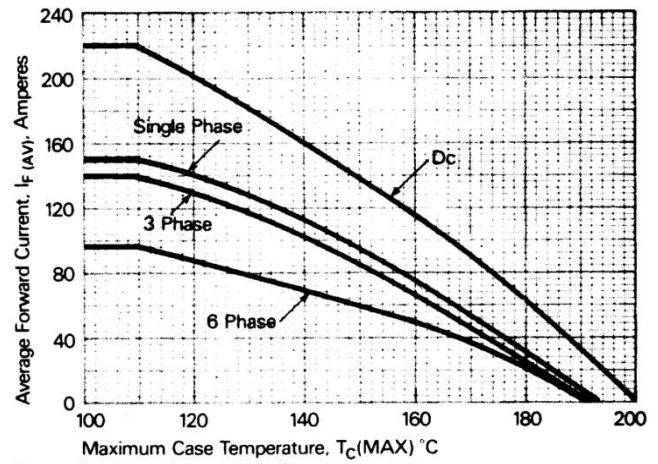
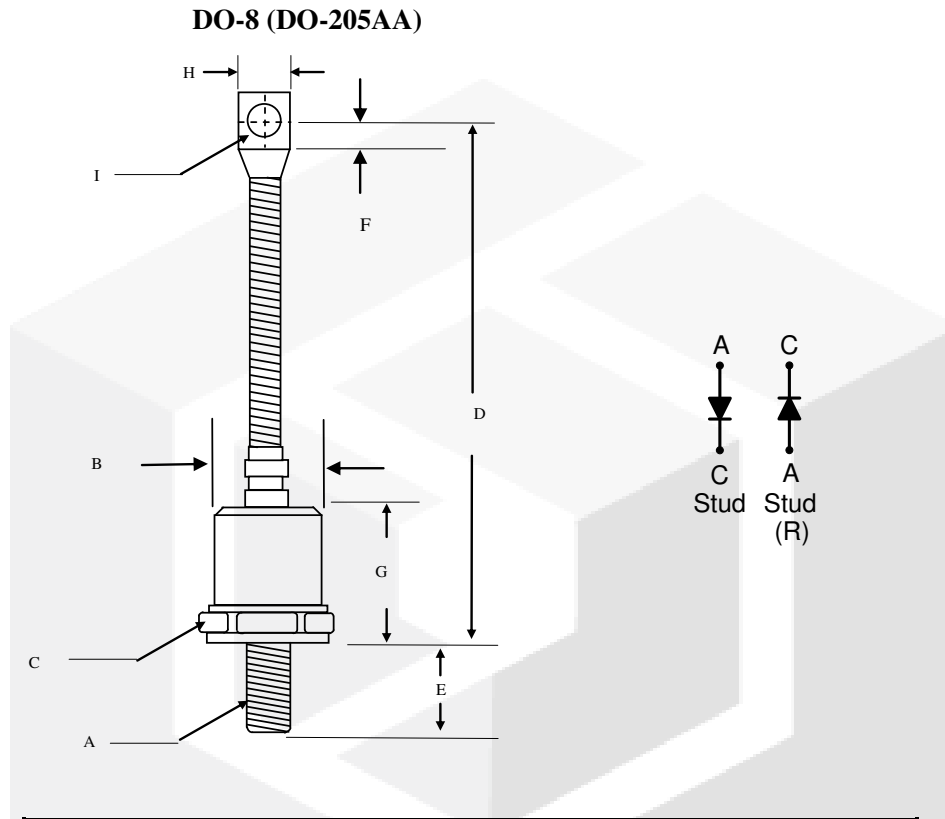

Figure 4. Forward current vs. Case temperature.

Package dimensions and terminal configuration

Product is marked with part number and terminal configuration.



	Inches		Millimeters	
	Min	Max	Min	Max
A	3/8-24 UNF			
B	----	φ0.930	----	φ23.5
C	1.050	1.060	26.67	26.92
D	4.300	4.700	109.22	119.38
E	----	0.690	----	17.00
F	0.260	----	6.50	----
G	----	0.940	----	24.00
H	----	0.600	----	15.23
I	0.276	0.286	7.010	7.260