

P	LTR	DESCRIPTION	DATE	DWN	APVD
A1		REVISE PER ECN-21-102315	12APR2021	A.L	H.L
A2		REVISE AS PER ECN-22-134287	12JAN2022	A.L	H.L
A3		REVISE PER PCN-22-135638	13SEP2022	M.C	H.L
B		ADD NEW PN	09JAN2023	M.C	H.L

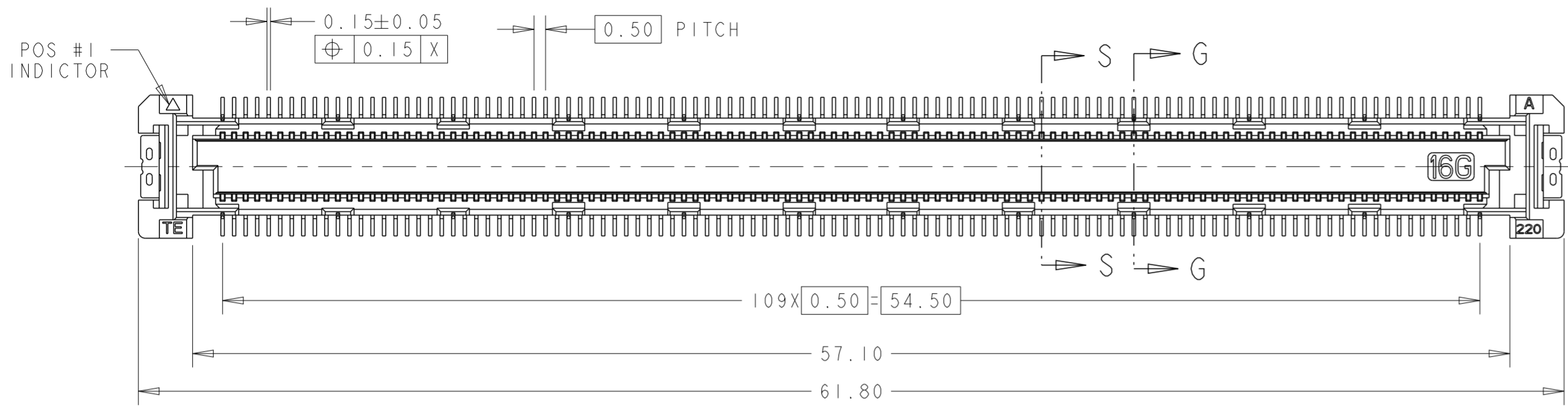

NOTES:

- MATERIAL
 HOUSING : HIGH TEMP THERMO PLASTIC UL94V-0
 CONTACT : COPPER ALLOY
 SOLDER PEG : COPPER ALLOY
- FINISH
 UNDERPLATED : 1.27um MIN. NICKEL ALL OVER
 CONTACT MATING AREA : MEETS THE PERFORMANCE REQUIREMENTS OF TE CONNECTIVITY PRODUCT SPECIFICATION 108-32658.
 SOLDER AREA : GOLD FLASH

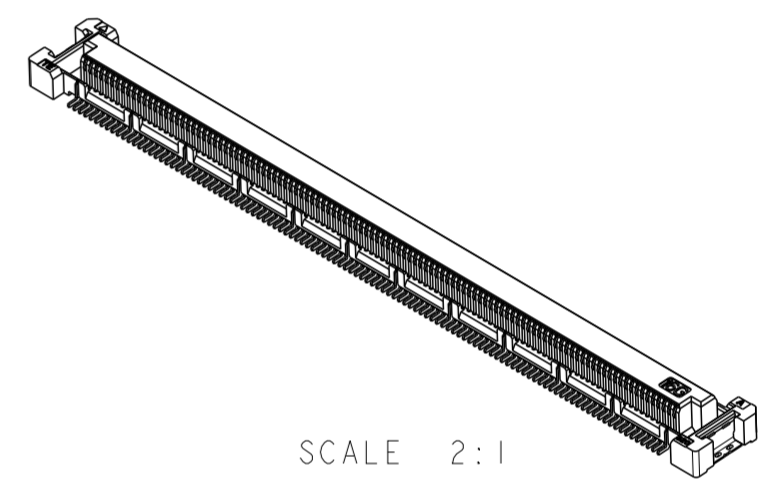
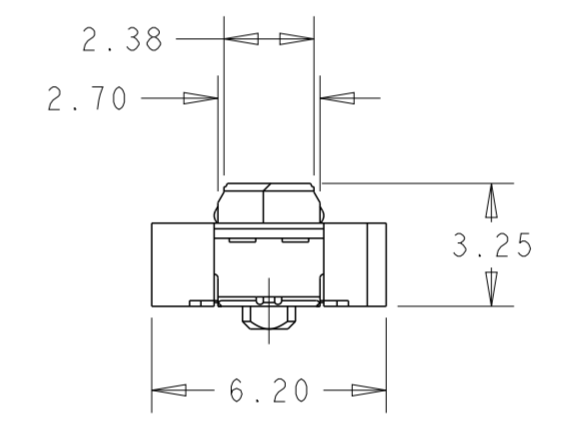
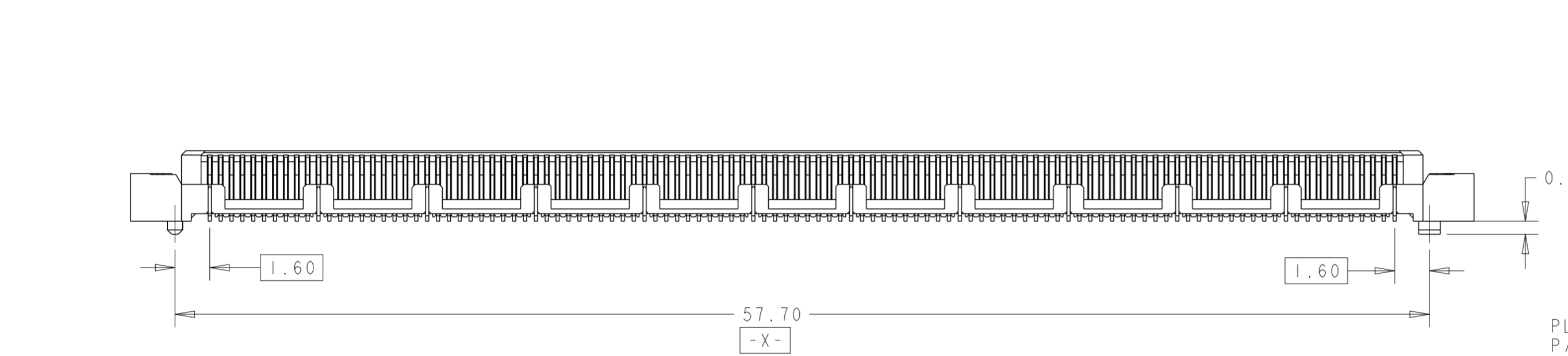

PLUG CONNECTOR
 P/N: 2357798-*

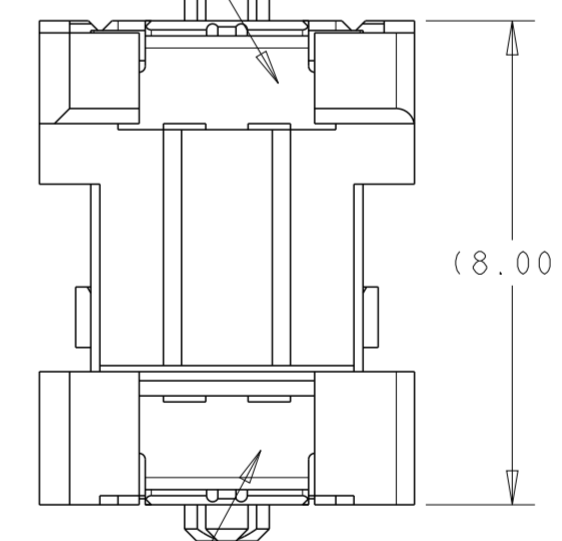

REC CONNECTOR
 P/N: 2357739-*

SCALE 8:1
 FULL-MATED CONDITION

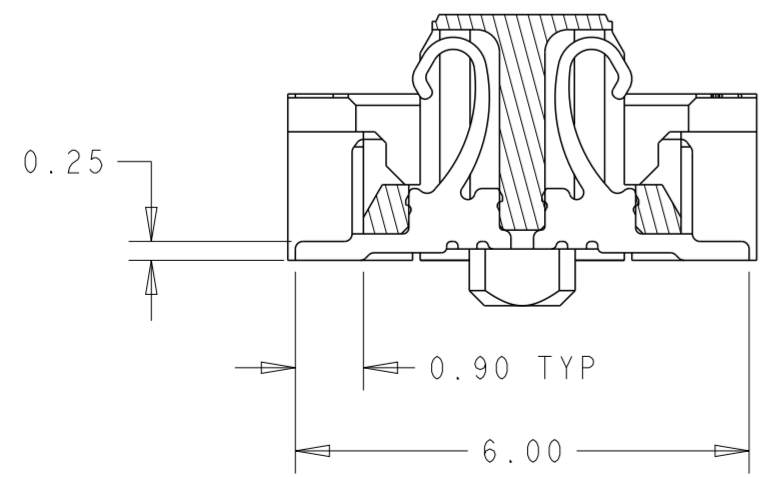
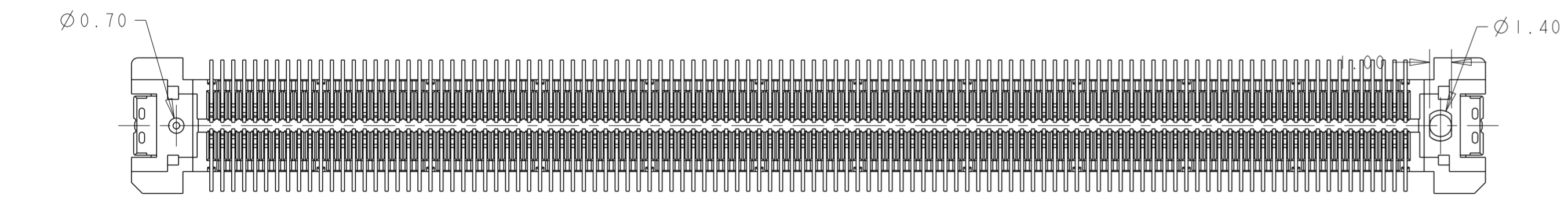
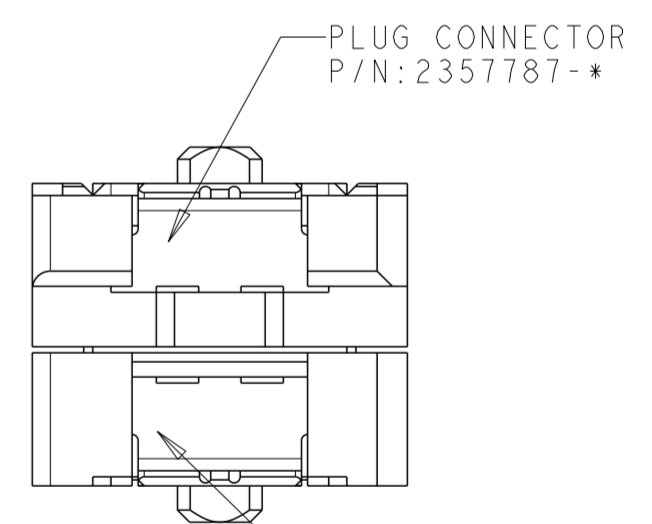

SECTION S-S
 SCALE 10:1
 (SIGNAL CONTACTS)

0.10
 ALL CONTACTS

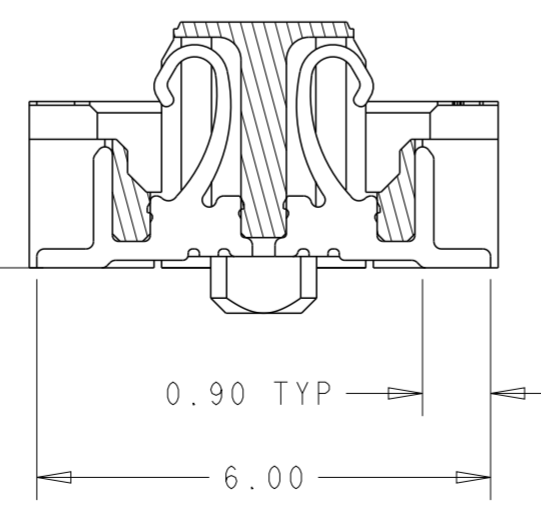

SECTION G-G
 SCALE 10:1
 (GROUND CONTACTS)

(B)

30u"	HARD TRAY	WITHOUT	2357739-7
30u"	HARD TRAY	WITH/WHITE	2357739-6
8u"	HARD TRAY	WITH/BLACK	2357739-5
8u"	TAPE & REEL	WITH/WHITE	2357739-3
8u"	HARD TRAY	WITH/WHITE	2357739-2
8u"	HARD TRAY	WITHOUT	2357739-1
MATING ZONE PRECIOUS PLATING	PACKAGE	CAP	P/N

THIS DRAWING IS A CONTROLLED DOCUMENT.

DIMENSIONS:	TOLERANCES UNLESS OTHERWISE SPECIFIED:	DWN	ART LIN	11JUN2019
mm	0 PLC ±1	CHK	HOPE LU	10OCT2019
	1 PLC ±0.3	APVD	HOPE LU	10OCT2019
	2 PLC ±0.15	PRODUCT SPEC		108-32658
	3 PLC ±0.05	APPLICATION SPEC		114-115003
	4 PLC ±0.0250	WEIGHT		-
	ANGLES ±3°	CUSTOMER DRAWING		
MATERIAL	FINISH	SCALE	1:1	SHEET
SEE NOTE 1	SEE NOTE 2			OF 5

TE Connectivity

STE

NAME
 4H RECEPTACLE ASSY 220POS
 FH 0.5 BTB 16Gbps
 WITH G-CONTACT

SIZE
 A200779

DRAWING NO
 C-2357739

RESTRICTED TO
 -

REV B

P	LTR	DESCRIPTION	DATE	DWN	APVD
-	-	SEE SHEET 1	-	-	-

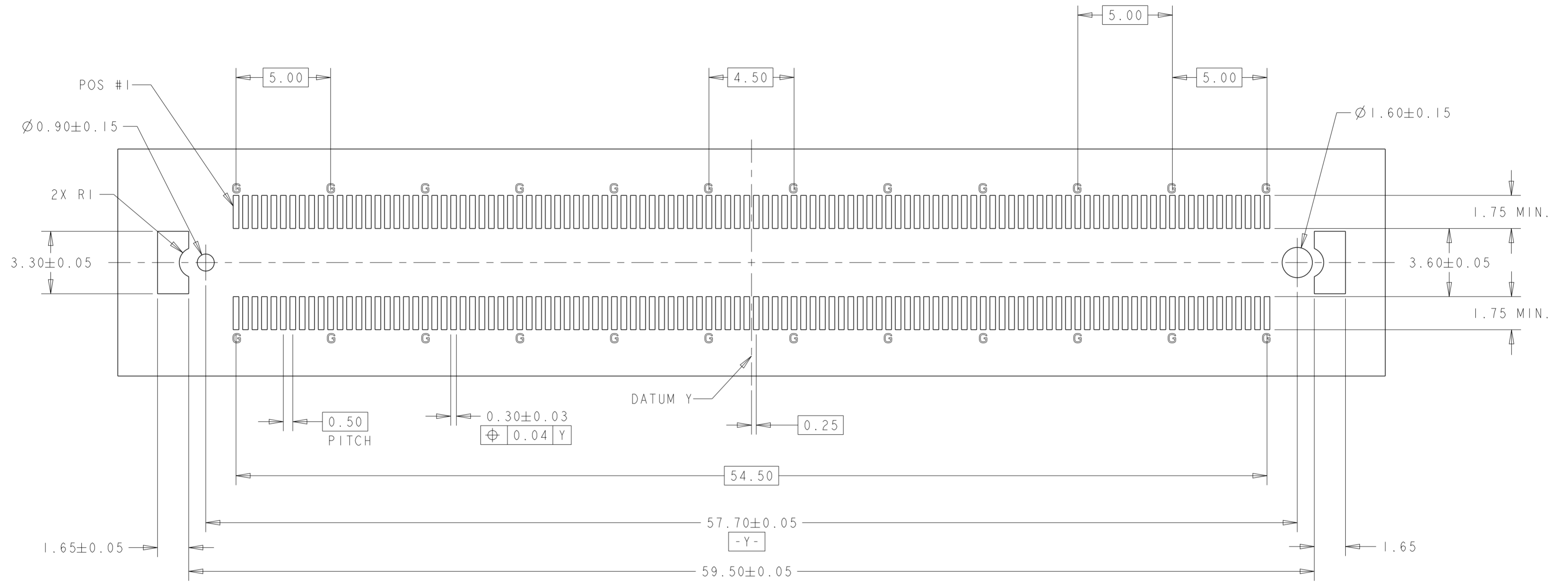

REFERENCE P.C. BOARD LAYOUT

G: Ground

THIS DRAWING IS A CONTROLLED DOCUMENT.		DWN ART LIN 11JUN2019	 TE Connectivity	
DIMENSIONS: mm		CHK HOPE LU 10OCT2019		
TOLERANCES UNLESS OTHERWISE SPECIFIED:		APVD HOPE LU 10OCT2019	NAME 4H RECEPTACLE ASSY 220POS FH 0.5 BTB 16Gbps WITH G-CONTACT	
0 PLC ±1 1 PLC ±0.3 2 PLC ±0.15 3 PLC ±0.05 4 PLC ±0.0250 ANGLES ±3°		PRODUCT SPEC 108-32658	SIZE A200779	
MATERIAL - SEE NOTE 1		APPLICATION SPEC 114-115003	CAGE CODE C-2357739	DRAWING NO - RESTRICTED TO -
FINISH -		WEIGHT -	SCALE 1:1	SHEET 2 OF 5
SEE NOTE 2		CUSTOMER DRAWING	REV B	

WITHOUT PICK UP CAP
2357739-1

REVISIONS				
P	LTR	DESCRIPTION	DATE	APVD
-	-	SEE SHEET 1	-	-

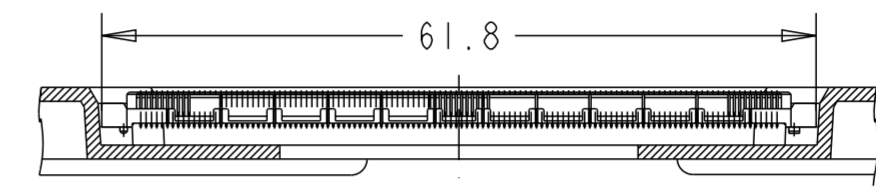
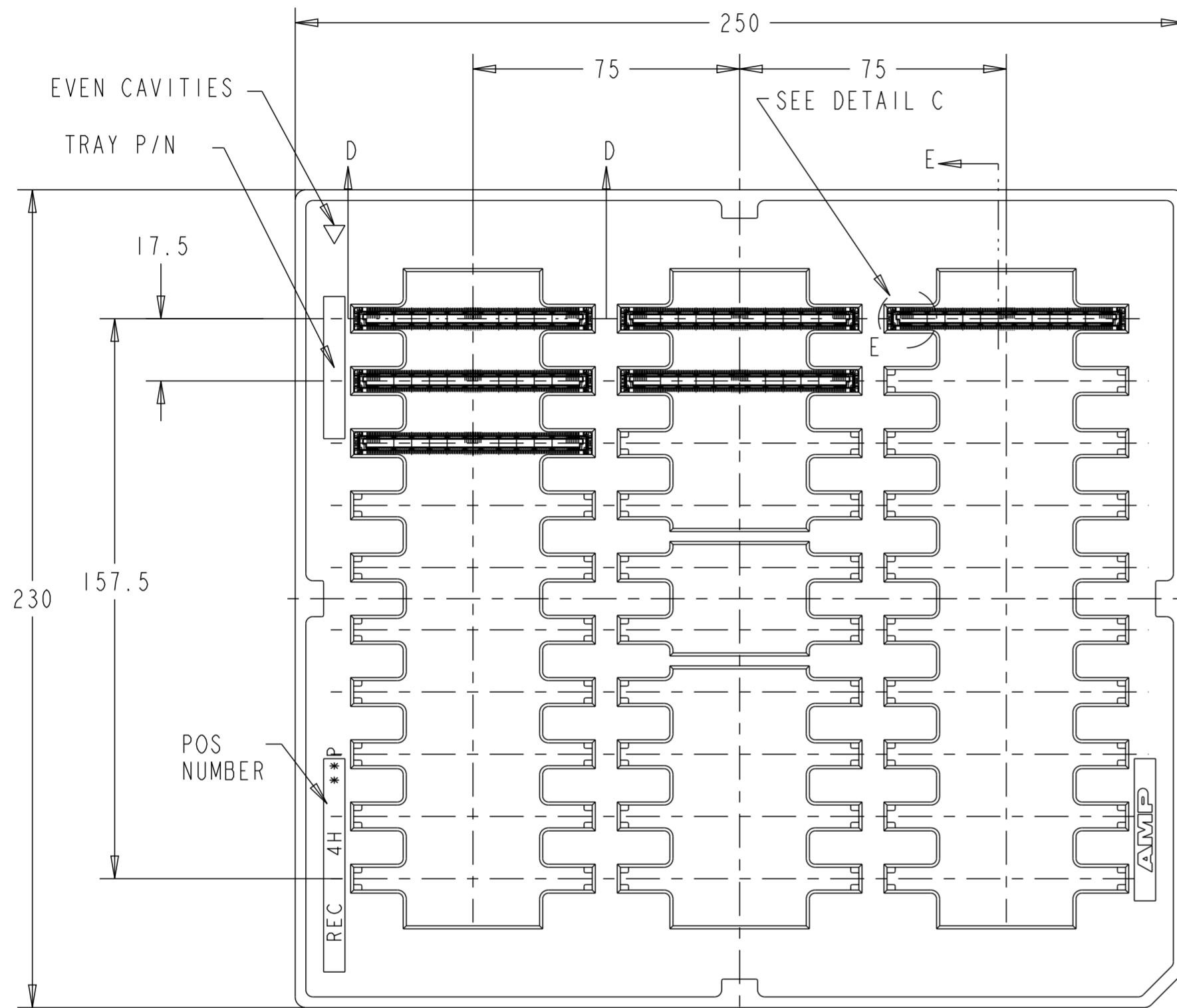

SECT. D-D
(SCALE 2:1)
(CONNECTOR NOT SECTION)

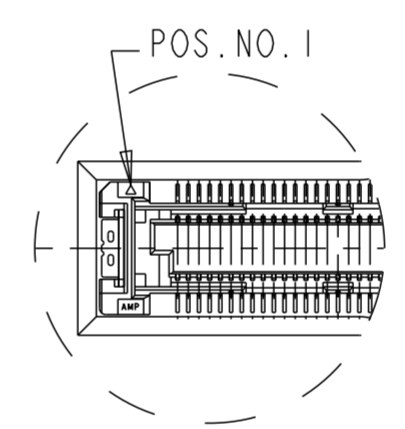

DETAIL C
(SCALE 2:1)

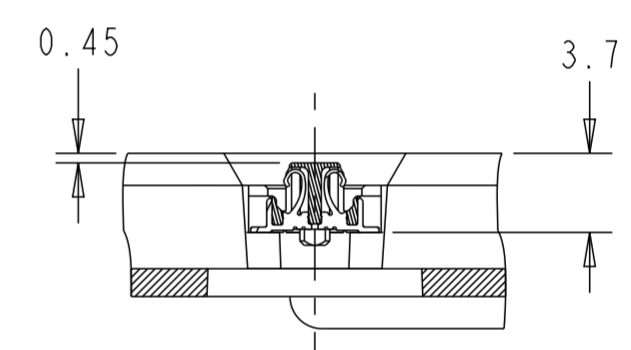

E-E
(SCALE 2:1)

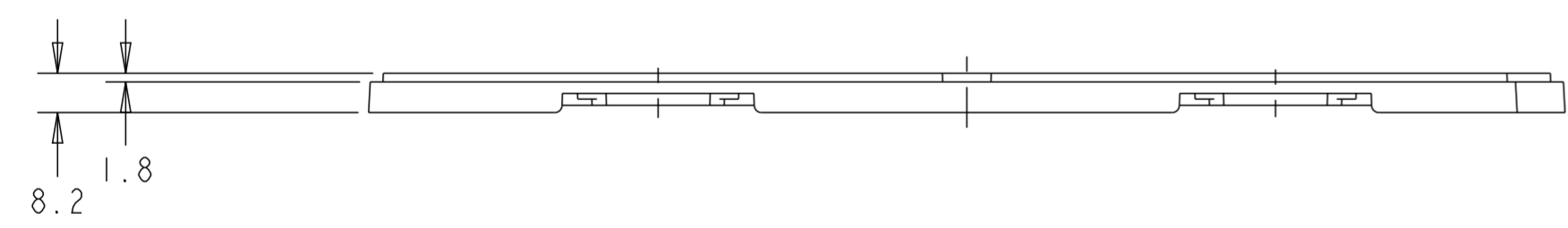

THIS DRAWING IS A CONTROLLED DOCUMENT.		DWN ART LIN 11JUN2019	TE Connectivity	
DIMENSIONS: mm		CHK HOPE LU 10OCT2019		
TOLERANCES UNLESS OTHERWISE SPECIFIED:		APVD HOPE LU 10OCT2019	NAME 4H RECEPTACLE ASSY 220POS FH 0.5 BTB 16Gbps WITH G-CONTACT	
0 PLC ±1 1 PLC ±0.3 2 PLC ±0.15 3 PLC ±0.05 4 PLC ±0.0250 ANGLES ±3°		PRODUCT SPEC 108-32658	SIZE A200779	
MATERIAL - SEE NOTE 1		APPLICATION SPEC 114-115003	DRAWING NO C-2357739	
FINISH -		WEIGHT -	RESTRICTED TO -	
CUSTOMER DRAWING		SCALE 1:1	SHEET 3 OF 5	
				REV B

REVISIONS					
P	LTR	DESCRIPTION	DATE	DWN	APVD
-	-	SEE SHEET 1	-	-	-

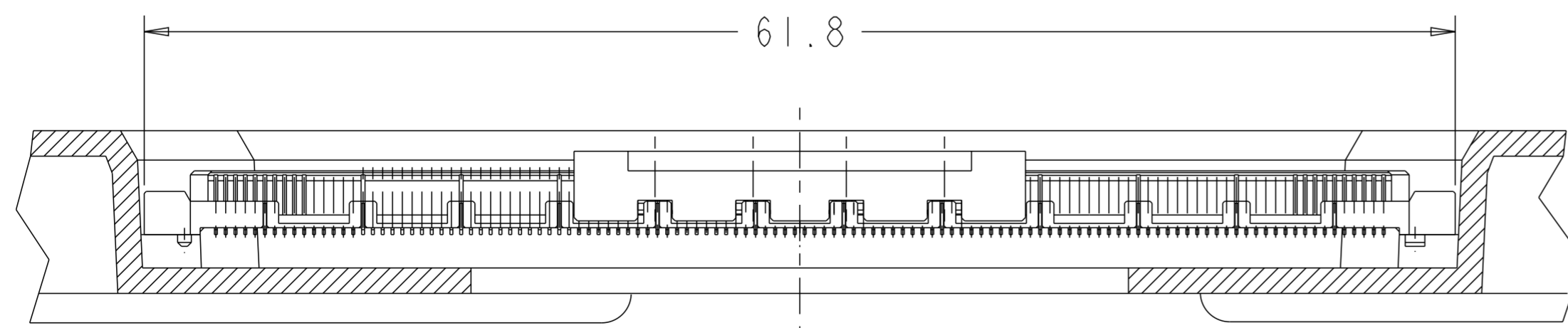
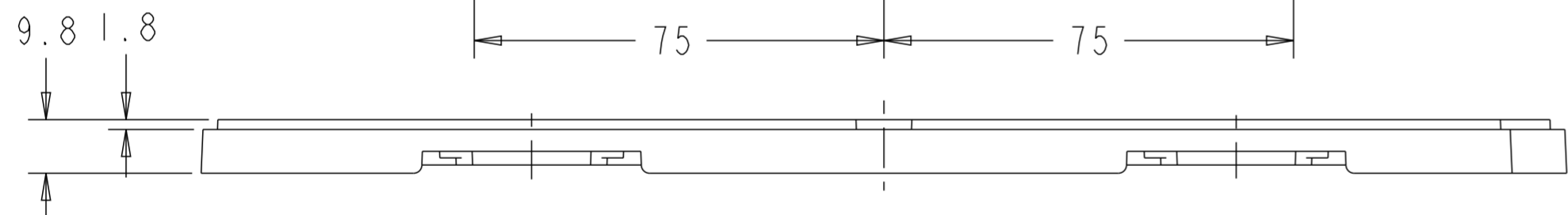
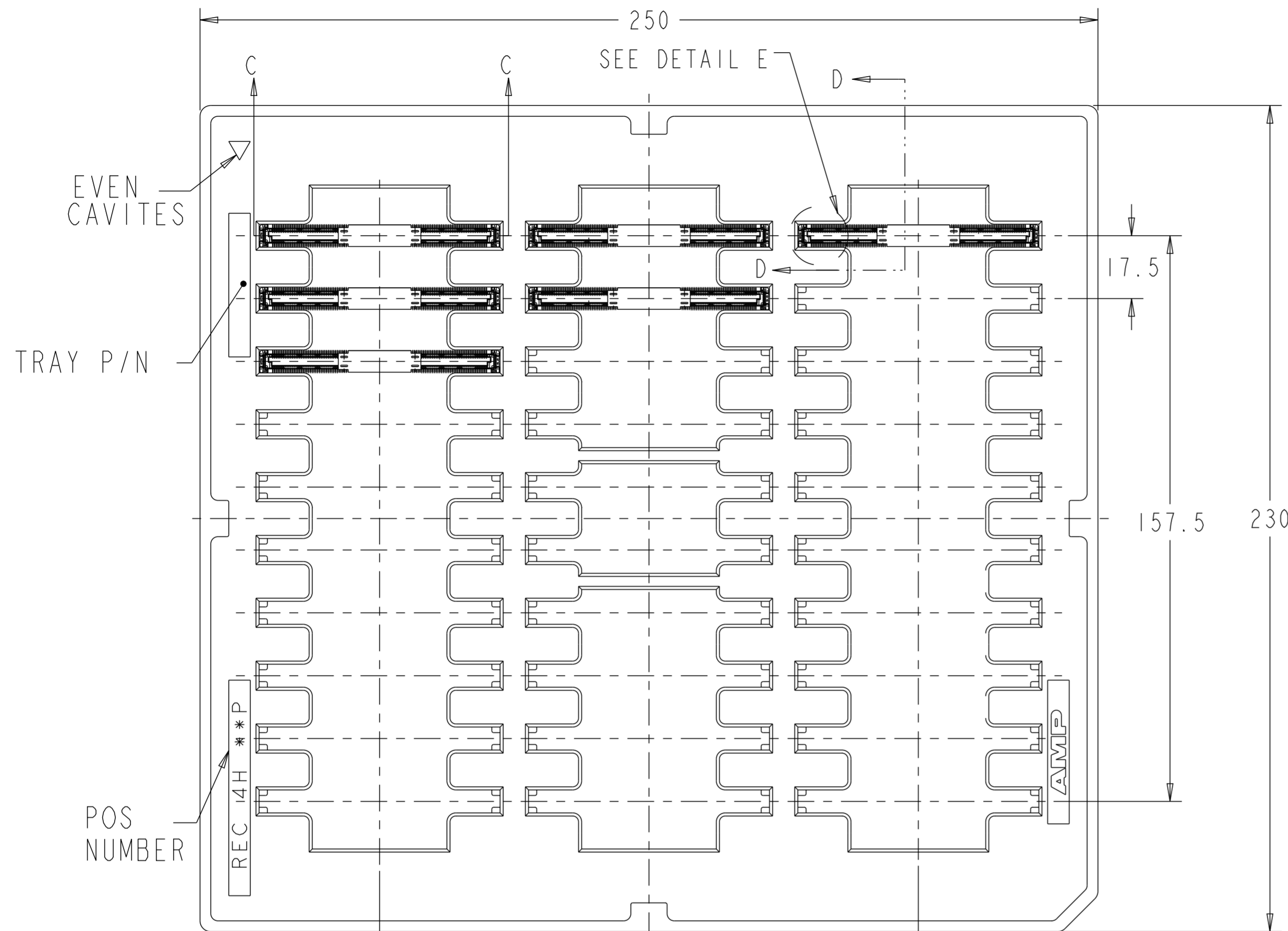

SECT. C-C
(SCALE 2:1)

WITH PICK UP CAP
2357739-2 & -5

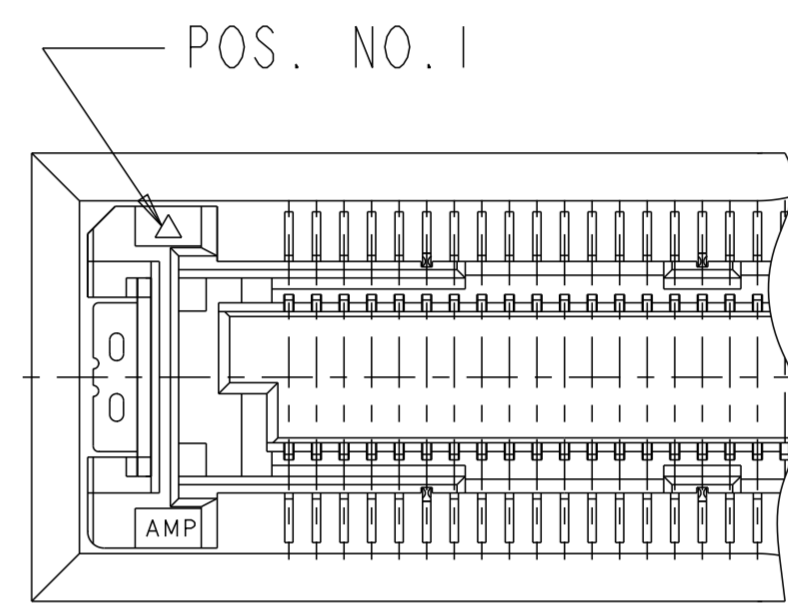

DETAIL E
(SCALE 4:1)

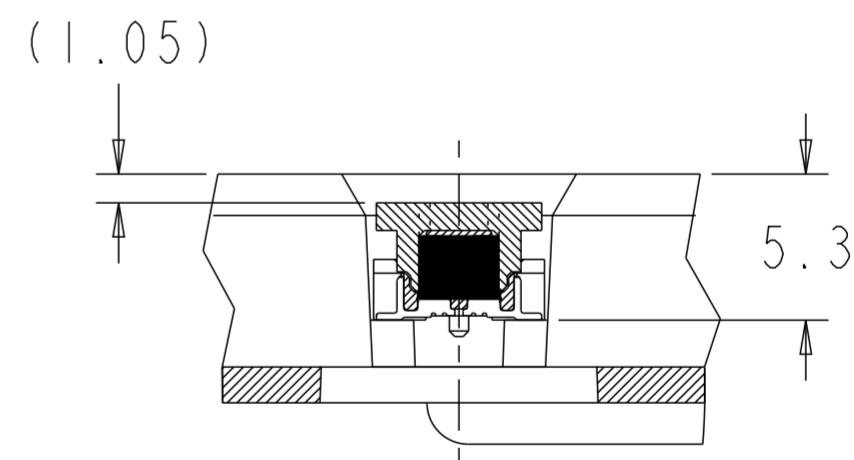

SECT. D-D
(SCALE 2:1)

THIS DRAWING IS A CONTROLLED DOCUMENT.		DWN ART LIN CHK HOPE LU	11 JUN 2019 10 OCT 2019	TE Connectivity	
DIMENSIONS: mm		APVD HOPE LU	10 OCT 2019		
TOLERANCES UNLESS OTHERWISE SPECIFIED:		PRODUCT SPEC	108-32658	SIZE	
0 PLC	±1	APPLICATION SPEC	114-115003	CAGE CODE	DRAWING NO
1 PLC	±0.3	WEIGHT	-	A200779	C-2357739
2 PLC	±0.15	MATERIAL		SCALE	SHEET
3 PLC	±0.05	SEE NOTE 1		1:1	4 OF 5
4 PLC	±0.0250	SEE NOTE 2		CUSTOMER DRAWING	REV
ANGLES	±3°	FINISH		B	

DIRECTION OFF TOP OF REEL →

REEL WITH PICK UP CAP
2357739-3

REVISIONS				
P	LTR	DESCRIPTION	DATE	APVD
-	-	SEE SHEET 1	-	-

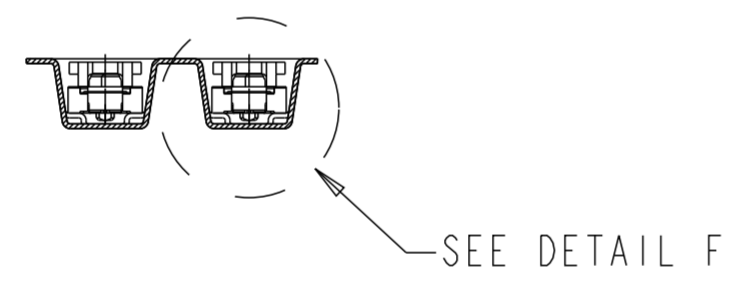
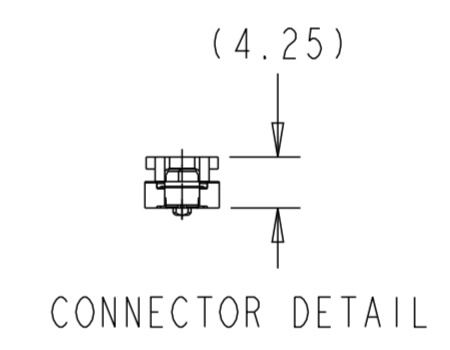
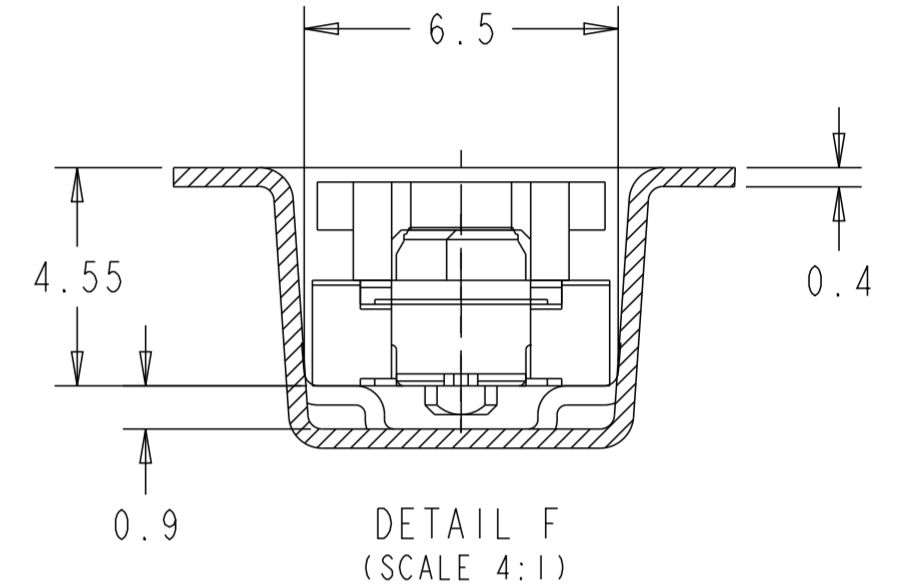
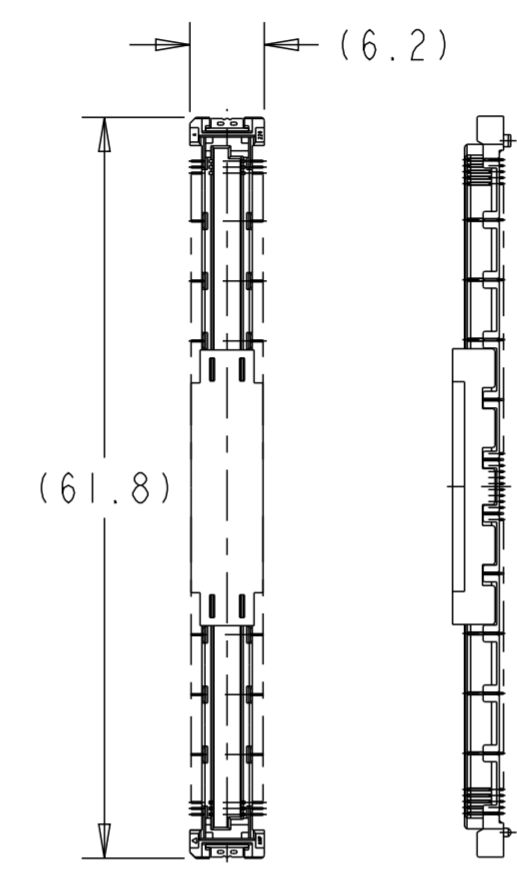
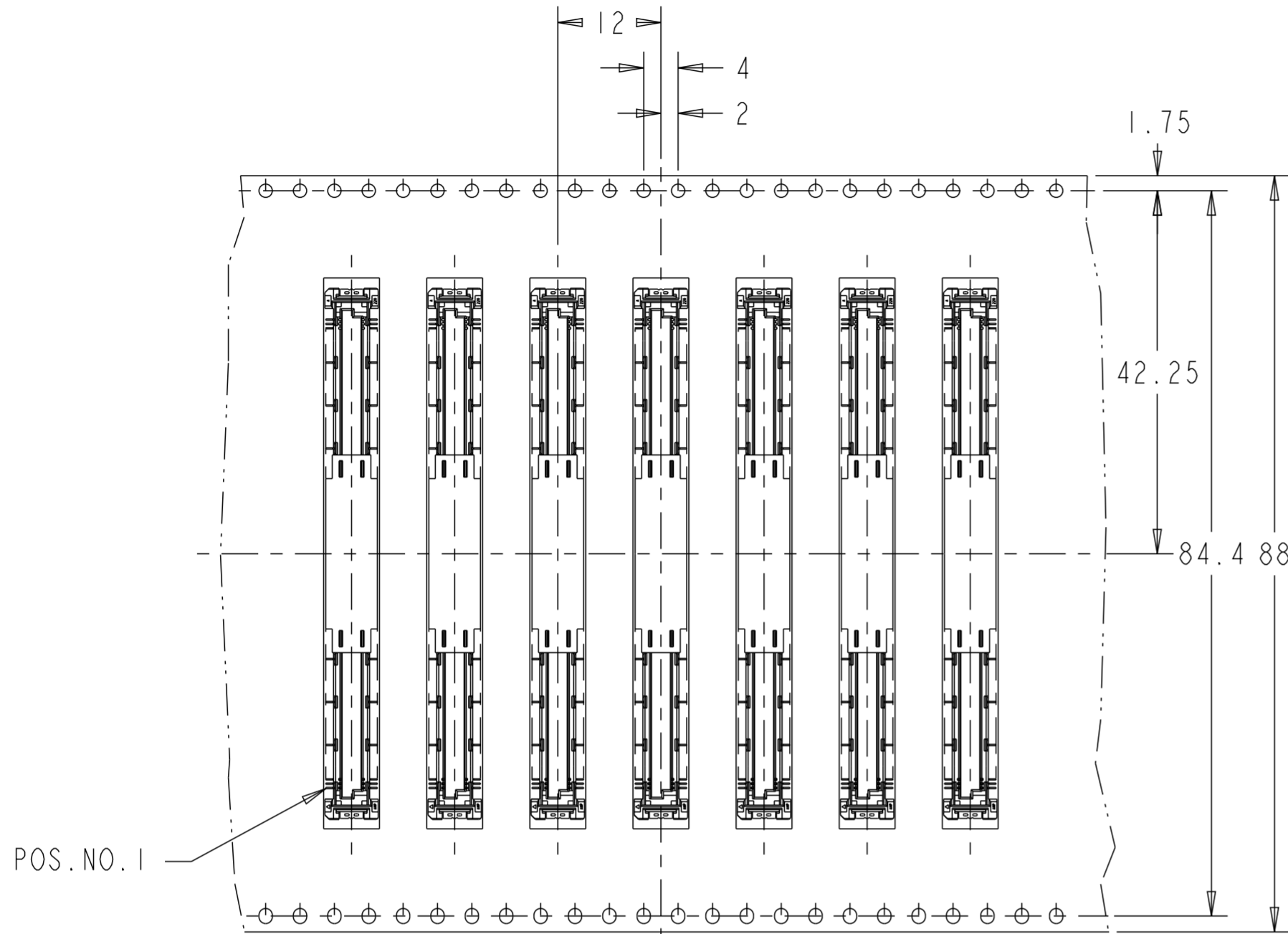

WEEDING THE COVER TAPE
AROUND THE OUTER
PERIPHERY IN
A TURN.

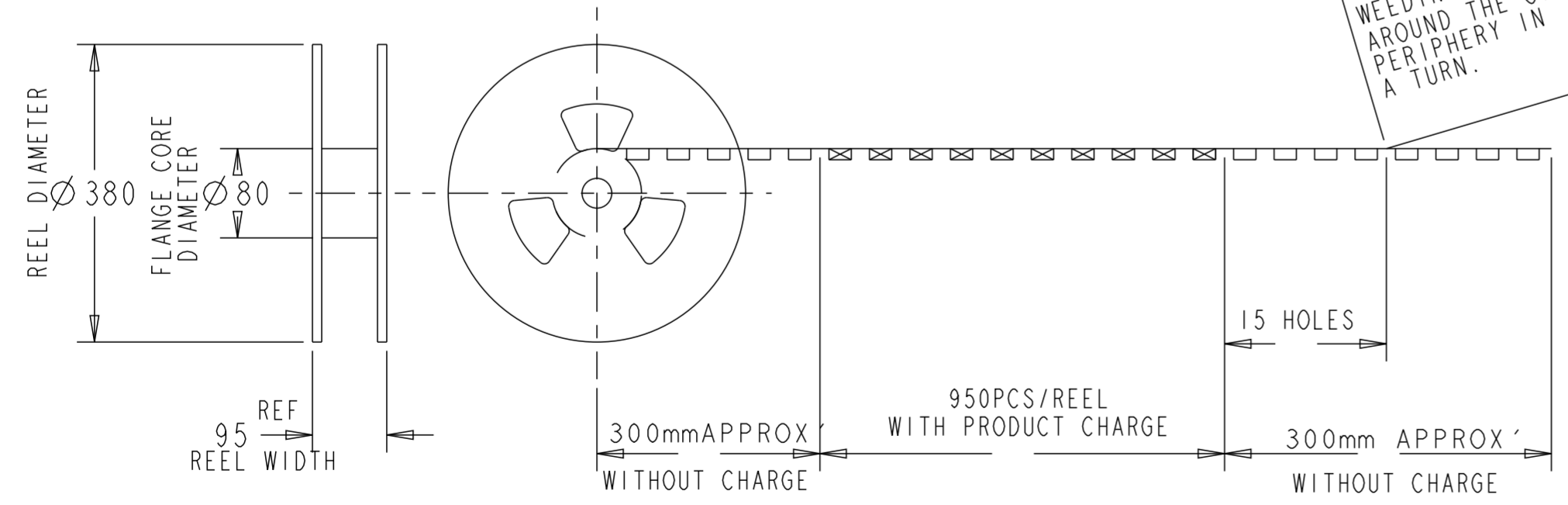

THIS DRAWING IS A CONTROLLED DOCUMENT.		DWN ART LIN 11 JUN 2019	TE Connectivity	
DIMENSIONS: mm		CHK HOPE LU 10 OCT 2019		
TOLERANCES UNLESS OTHERWISE SPECIFIED:		APVD HOPE LU 10 OCT 2019	NAME 4H RECEPTACLE ASSY 220POS FH 0.5 BTB 16Gbps WITH G-CONTACT	
0 PLC ±1		PRODUCT SPEC 108-32658	SIZE A2	
1 PLC ±0.3		APPLICATION SPEC 114-115003	CAGE CODE 00779	DRAWING NO C-2357739
2 PLC ±0.15		WEIGHT -	RESTRICTED TO -	
3 PLC ±0.05		MATERIAL -	SCALE 1:1	
4 PLC ±0.0250		SEE NOTE 1	SHEET 5 OF 5	
ANGLES ±3°		SEE NOTE 2	REV B	
FINISH -		CUSTOMER DRAWING		