

AN-1505 LM3207 Evaluation Board

1 Introduction

The LM3207 evaluation board is a working demonstration of a step down DC-DC converter. This user's guide contains information about the evaluation board and board layout considerations. For further information on buck converter topology, device electrical characteristics, and component selection, please refer to *LM3207 650mA Miniature, Adjustable, Step-Down DC-DC Converter for RF Power Amplifiers with Integrated Vref LDO* ([SNVS400](#)).

2 General Description

The LM3207 is a DC-DC converter optimized for powering RF power amplifiers (RFPAs) from a single Lithium-Ion cell, however the device may be used in many other applications. The LM3207 steps down an input voltage range from 2.7V to 5.5V to a variable output voltage range from 0.8V to 3.6V. Output voltage is set using a V_{CON} analog input for controlling power levels and efficiency of the RF PA.

The LM3207 also provides a regulated reference voltage (V_{ref}) required by linear RF power amplifiers through an integrated LDO with a nominal has a maximum I_{ref} of 10 mA.

The LM3207 offers superior performance for powering WCDMA / CDMA RF power amplifiers and similar applications. Fixed-frequency PWM operation minimizes RF interference. Shutdown function turns the device off and reduces battery consumption to 0.01 μ A (typ).

The LM3207 is available in a 9-pin lead free DSBGA package. A high switching frequency (2 MHz) allows use of tiny surface-mount components. Only four small external components are required, an inductor and three ceramic capacitors.

3 Operating Conditions

- V_{IN} range: $2.7V \leq V_{IN} \leq 5.5V$
- V_{CON} range: $0.32V \leq V_{CON} \leq 1.44V$
- V_{OUT} equation: $V_{OUT} = 2.5 \times V_{CON}$
- I_{OUT} range: $0 mA \leq I_{OUT} \leq 650 mA$

4 Typical Application

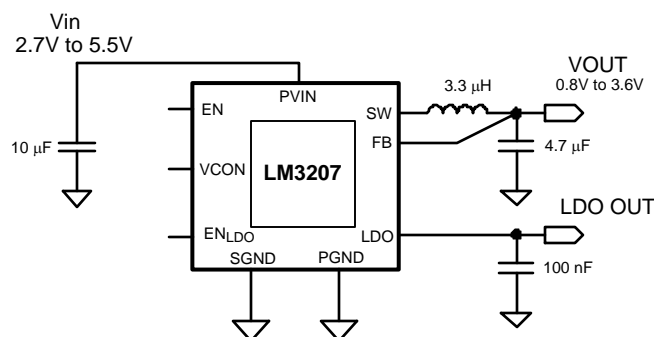

All trademarks are the property of their respective owners.

5 Connection Diagram and Package Mark Information

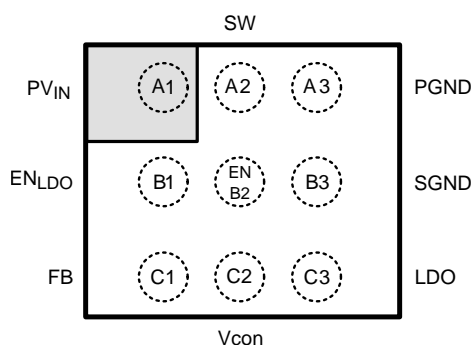

Top View

Figure 1. 9-Bump Thin DSBGA Package, Large Bump

Table 1. Pin Descriptions

Pin #	Name	Description
A1	PV _{IN}	Power Supply Voltage Input to the internal PFET switch.
B1	EN _{LDO}	LDO Enable Input. Set this digital input high to turn on LDO (EN pin must also be set high). For shutdown, set low.
C1	FB	Feedback Analog Input. Connect to the output at the output filter capacitor.
C2	V _{CON}	Voltage Control Analog input. V _{CON} controls V _{OUT} in PWM mode.
C3	LDO	LDO Output Voltage.
B3	SGND	Analog and Control Ground
A3	PGND	Power Ground
A2	SW	Switch node connection to the internal PFET switch and NFET synchronous rectifier. Connect to an inductor with a saturation current rating that exceeds the maximum Switch Peak Current Limit specification of the LM3207.
B2	EN	PWM enable Input. Set this digital input high for normal operation. For shutdown, set low.

6 Bill of Materials for Common Configurations

	Manufacture	Manufacture #	Description
C1 (input C)	TDK	C1608X5R0J106M	10 μF,6.3V,10%,0603
C2 (output C)	TDK	C1608X5R0J475M	4.7 μF,6.3V,10%,0603
C3 (optional, input C)			0.1 μF,25V , 0402 ⁽¹⁾
C4 (optional, filter for V _{CON})			10 - 100 pF, 25V , 0402 ⁽¹⁾
C7 (LDO Cap)	TDK	C1005X5R1A104KT	100nF,10V, 0402
L1 (inductor)	Taiyo-Yuden	NR3015T3R3M	3.3 μH, 1210mA, 3x3x1.5 mm
V _{IN} banana jack - red	Johnson Components	108-0902-001	connector, insulated banana jack (red)
V _{out} banana jack - yellow	Johnson Components	108-0907-001	connector, insulated banana jack (yellow)
GND banana jack - black	Johnson Components	108-0903-001	connector, insulated banana jack (black)
LDO Out banana jack - yellow	Johnson Components	108-0907-001	connector, insulated banana jack (yellow)

⁽¹⁾ C3 and C4 are recommended for a better noise performance.

7 Board Layout Considerations

The LM3207 converts higher input voltage to lower output voltage with high efficiency. This is achieved with an inductor-based switching topology. During the first half of the switching cycle, the internal PMOS switch turns on, the input voltage is applied to the inductor, and the current flows from P_{VIN} line to the output capacitor (C2) through the inductor. During the second half cycle, the PMOS turns off and the internal NMOS turns on. The inductor current continues to flow via the inductor from the device PGND line to the output capacitor (C2). The inductor current continues to flow via the inductor from the device PGND line to the output capacitor (C2) .

Referring to [Figure 2](#), the LM3207 has two major current loops where pulse and ripple current flow. The loop shown in the left hand side is important because pulse current flows in this path. In the loop on the right hand side, the current waveform in this path is triangular. Pulse current has many high-frequency components due to fast di/dt . Triangular ripple current also has wide high-frequency components. Board layout and circuit pattern design of these two loops are key factors for reducing noise radiation and achieving stable operation. Other lines, such as input and output terminals are DC current, therefore pattern width (current capability) and DCR drop considerations are needed.

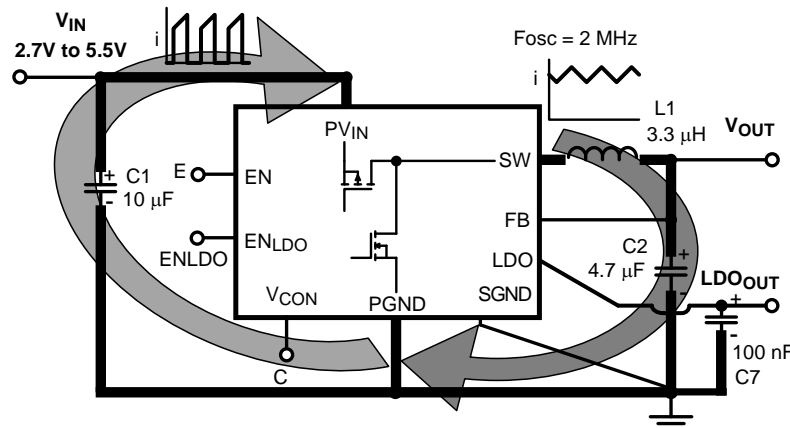

Figure 2. Current Loop

Board Layout Flow

1. Minimize C1, PV_{IN} , and PGND loop. These traces should be as wide and short as possible. This is most important.
2. Minimize L1, C2, SW and PGND loop. These traces also should be wide and short. This is the second priority.
3. Above layout patterns should be placed on the component side of the PCB to minimize parasitic inductance and resistance due to via-holes. It may be a good idea that the SW to L1 path is routed between C2(+) and C2(-) land patterns. If vias are used in these large current paths, multiple via-holes should be used if possible.
4. Connect C1(-), C2(-) and PGND with wide GND pattern. This pattern should be short, so C1(-), C2(-), and PGND should be as close as possible. Then connect to a PCB common GND pattern with as many via-holes as possible.
5. SGND should not connect directly to PGND. Connecting these pins under the device should be avoided. (If possible, connect SGND to the common port of C1(-), C2(-) and PGND.)
6. FB line should be protected from noise. It is a good idea to use an inner GND layer (if available) as a shield.
7. The LDO Cap C7 should be placed as close to the PA as possible and as far away from the switcher to suppress high frequency switch noises.

NOTE: The evaluation board shown in [Figure 3](#) and [Figure 4](#) for the LM3207 was designed with the considerations mentioned above, and it shows good performance. However some aspects have not been optimized because of limitations due to evaluation-specific requirements. The board can be used as a reference. For specific questions, please refer to Texas Instruments.

8 Evaluation Board Layout

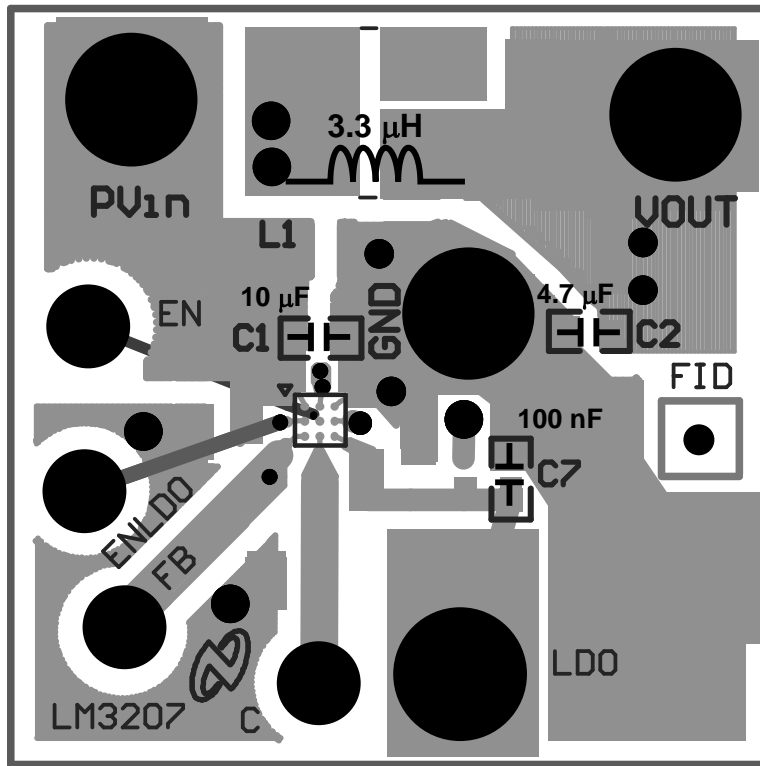

Figure 3. Top Layer

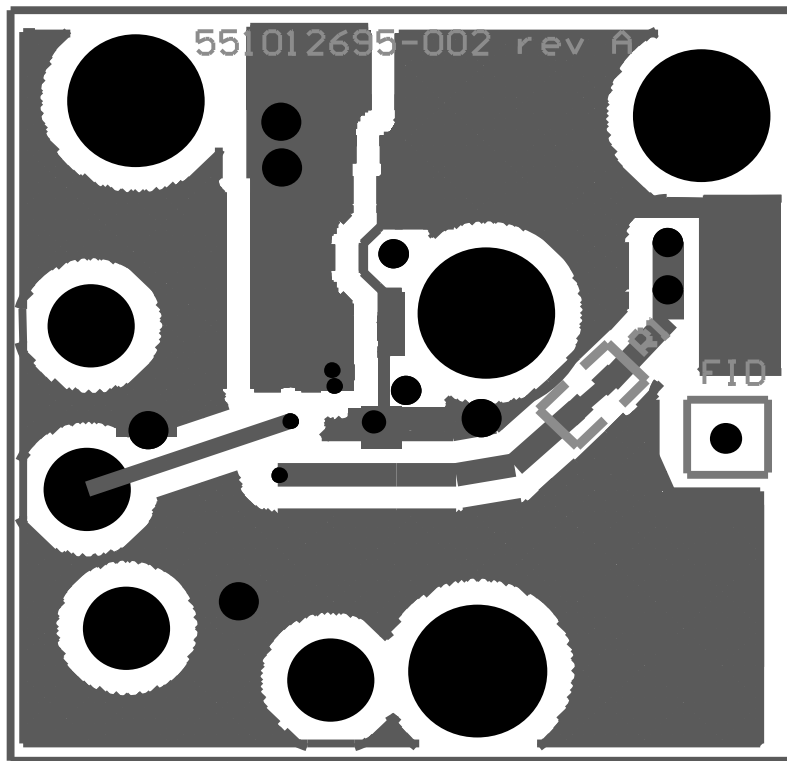

Figure 4. Bottom Layer

IMPORTANT NOTICE

Texas Instruments Incorporated and its subsidiaries (TI) reserve the right to make corrections, enhancements, improvements and other changes to its semiconductor products and services per JESD46, latest issue, and to discontinue any product or service per JESD48, latest issue. Buyers should obtain the latest relevant information before placing orders and should verify that such information is current and complete. All semiconductor products (also referred to herein as "components") are sold subject to TI's terms and conditions of sale supplied at the time of order acknowledgment.

TI warrants performance of its components to the specifications applicable at the time of sale, in accordance with the warranty in TI's terms and conditions of sale of semiconductor products. Testing and other quality control techniques are used to the extent TI deems necessary to support this warranty. Except where mandated by applicable law, testing of all parameters of each component is not necessarily performed.

TI assumes no liability for applications assistance or the design of Buyers' products. Buyers are responsible for their products and applications using TI components. To minimize the risks associated with Buyers' products and applications, Buyers should provide adequate design and operating safeguards.

TI does not warrant or represent that any license, either express or implied, is granted under any patent right, copyright, mask work right, or other intellectual property right relating to any combination, machine, or process in which TI components or services are used. Information published by TI regarding third-party products or services does not constitute a license to use such products or services or a warranty or endorsement thereof. Use of such information may require a license from a third party under the patents or other intellectual property of the third party, or a license from TI under the patents or other intellectual property of TI.

Reproduction of significant portions of TI information in TI data books or data sheets is permissible only if reproduction is without alteration and is accompanied by all associated warranties, conditions, limitations, and notices. TI is not responsible or liable for such altered documentation. Information of third parties may be subject to additional restrictions.

Resale of TI components or services with statements different from or beyond the parameters stated by TI for that component or service voids all express and any implied warranties for the associated TI component or service and is an unfair and deceptive business practice. TI is not responsible or liable for any such statements.

Buyer acknowledges and agrees that it is solely responsible for compliance with all legal, regulatory and safety-related requirements concerning its products, and any use of TI components in its applications, notwithstanding any applications-related information or support that may be provided by TI. Buyer represents and agrees that it has all the necessary expertise to create and implement safeguards which anticipate dangerous consequences of failures, monitor failures and their consequences, lessen the likelihood of failures that might cause harm and take appropriate remedial actions. Buyer will fully indemnify TI and its representatives against any damages arising out of the use of any TI components in safety-critical applications.

In some cases, TI components may be promoted specifically to facilitate safety-related applications. With such components, TI's goal is to help enable customers to design and create their own end-product solutions that meet applicable functional safety standards and requirements. Nonetheless, such components are subject to these terms.

No TI components are authorized for use in FDA Class III (or similar life-critical medical equipment) unless authorized officers of the parties have executed a special agreement specifically governing such use.

Only those TI components which TI has specifically designated as military grade or "enhanced plastic" are designed and intended for use in military/aerospace applications or environments. Buyer acknowledges and agrees that any military or aerospace use of TI components which have **not** been so designated is solely at the Buyer's risk, and that Buyer is solely responsible for compliance with all legal and regulatory requirements in connection with such use.

TI has specifically designated certain components as meeting ISO/TS16949 requirements, mainly for automotive use. In any case of use of non-designated products, TI will not be responsible for any failure to meet ISO/TS16949.

Products

Audio	www.ti.com/audio
Amplifiers	amplifier.ti.com
Data Converters	dataconverter.ti.com
DLP® Products	www.dlp.com
DSP	dsp.ti.com
Clocks and Timers	www.ti.com/clocks
Interface	interface.ti.com
Logic	logic.ti.com
Power Mgmt	power.ti.com
Microcontrollers	microcontroller.ti.com
RFID	www.ti-rfid.com
OMAP Applications Processors	www.ti.com/omap
Wireless Connectivity	www.ti.com/wirelessconnectivity

Applications

Automotive and Transportation	www.ti.com/automotive
Communications and Telecom	www.ti.com/communications
Computers and Peripherals	www.ti.com/computers
Consumer Electronics	www.ti.com/consumer-apps
Energy and Lighting	www.ti.com/energy
Industrial	www.ti.com/industrial
Medical	www.ti.com/medical
Security	www.ti.com/security
Space, Avionics and Defense	www.ti.com/space-avionics-defense
Video and Imaging	www.ti.com/video

TI E2E Community

e2e.ti.com